

370-Maxi Side Bars

The Maxi Side Bars protect your vehicle from on and off road hazards. The Maxi Side Bars are a great step to make entry and exit from and into your vehicle easier. Manufactured from heavy gauge .090 X 3" diameter steel tubing. Uniquely positioned mounting brackets make installation easy. Olympic 4x4 Products are serviced by our factory. We provide answers to installation questions. We ship parts ASAP. Try us before the hassle of returning Olympic 4x4 Products to your retailer or mail order specialist.

For assistance please call 800-777-0878.

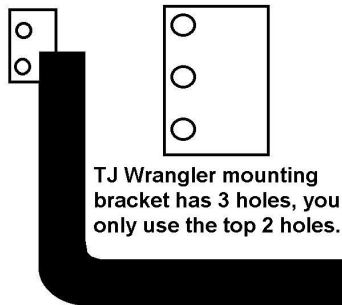

TJ Wrangler mounting bracket has 3 holes, you only use the top 2 holes.

Hardware list:

8 3/8" self tapping bolts

Parts list:

Maxi nerf bar (L&R)

Tools required:

- 3/8" or 1/2" ratchet wrench
- Socket sizes: 9/16"
- Center punch
- Drill bit sizes: 3/16" and 5/16"
- Drill motor
- Jack stands
- Thread cutting oil or tapping compound

Step 1. Position nerf bar mounting brackets against vehicle frame and hold in place with jack stands. The longer leg of the nerf bar goes towards the front of the vehicle.

Note: 1997 and newer Wranglers nerf bars have 3 mounting holes on the mounting bracket, but you will only use the top two holes.

Step 2. Mark the holes you need to drill in the frame once you have the nerf bars positioned how you like them. Then remove nerf bar.

Step 3. Drill 3/16" pilot hole where you marked followed by a 5/16" hole.

Step 4. Replace nerf bar and secure using 3/8" self-tapping bolts. A cutting oil or tapping compound should be used when installing the self-tapping bolts. **DO NOT** use WD-40, grease, or other lubricating oils. They should also be tightened down slowly and backed out frequently to remove chips when tapping the hole.