



Installation Instructions



Product: **Adjustable Trackbar**

Part Number: **PN OGS121**

Application: **Jeep Wrangler JK, 2007+ (front)**

Welcome

CONGRATULATIONS on your purchase of a new JKS Adjustable Trackbar! At JKS Manufacturing, we are committed to providing you with the best products available and your satisfaction is our first priority.

PLEASE READ these Installation Instructions carefully, and save them for future reference, as they contain important installation and maintenance information.

Important

NOT COMPATIBLE WITH right hand drive vehicles.

CHECK TORQUE SPECIFICATIONS regularly.

Tools Required

- Hydraulic Floor Jack & Jack Stands
- Metric/Standard Socket Wrench Set
- Torque Wrench
- 1-7/16" Open-End Wrench
- Tape Measure
- Heavy Duty Ratchet Strap *
- Anti-Seize Lubricant
- Factory Service Manual (recommended)

* Asterisk denotes tools that are not required for some applications. Thoroughly read instructions first to determine which tools will be required for your application.

Parts

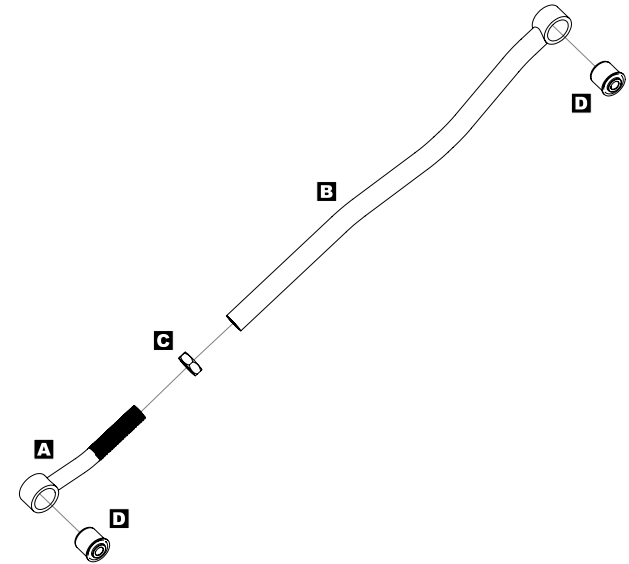

	DESCRIPTION	QTY
A	Male Threaded (Axle) End	1
B	Female Threaded (Chassis) End	1
C	1" NF Jam Nut	1
D	Rubber Bushing	2

Installation

- ❑ **1. REMOVE FRONT TRACK BAR**
 - Raise and support the vehicle chassis with jack stands positioned behind the front lower suspension arm brackets.
 - Raise and support the front axle housing with a hydraulic jack to relieve any tension from the mounting bolts.
 - Remove the front track bar mounting hardware from the axle and chassis brackets per the factory service manual instructions for your vehicle. Retain original hardware.
 - Remove original track bar from vehicle.

❑ 2. MOUNT ADJUSTABLE TRACKBAR TO CHASSIS BRACKET

- Apply anti-seize lubricant to bolt threads of original track bar mounting hardware.
- Insert Chassis End (B) of Adjustable Trackbar into the chassis bracket.

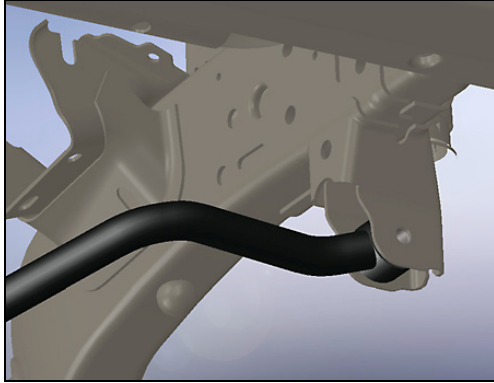

- Loosely install the original mounting hardware.

❑ 3. CENTER FRONT AXLE HOUSING

- Remove jack stands and lower vehicle to ground.

HINT: Vehicle must be at normal ride height, on level ground, with the suspension supporting the full vehicle weight.

- Determine if the axle housing is centered by measuring the distance between the tire and chassis, using the exact same points on each side of the vehicle to ensure accuracy.



HINT: For example, measure from the edge of a tire tread lug to the outboard side of the chassis, then repeat the measurement on the other side of vehicle using exact same points.

- If the two measurements are equal, the axle is centered. If the measurements vary, divide the difference in half to determine the amount of adjustment required.

HINT: If the axle housing is not centered, the chassis can be laterally shifted using either of the following methods.

Ratchet Strap (preferred)

- Attach a heavy duty ratchet strap to the chassis on one side of the vehicle, and to the axle housing on the other side.
- Tighten the strap in small increments to pull the chassis in alignment with the axle.
- Take measurements after each adjustment until centered.

Steering Wheel

- Have a partner turn the steering wheel in small increments to shift the vehicle chassis side-to-side.
- After each adjustment, have your partner hold the steering wheel steady while you take measurements.

❑ 4. SET ADJUSTABLE TRACKBAR LENGTH AND MOUNT TO AXLE

- With the axle housing centered beneath the chassis, adjust the length of Adjustable Trackbar by rotating the Axle End (A) until the steel sleeve in the Rubber Bushing (D) aligns with the mounting holes on the axle bracket.
- Apply anti-seize lubricant to original mounting bolt threads and adjustment threads of trackbar.
- Mount Axle End (A) of Adjustable Trackbar to the axle bracket by loosely installing the original mounting hardware.

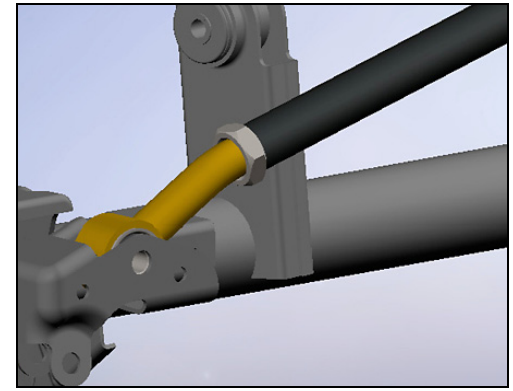

HINT: Bend in axle (gold) end of trackbar must point up to prevent interference from occurring when suspension articulates.

❑ 5. POST-INSTALLATION

- Take measurements again to ensure axle housing is perfectly centered and make any final adjustments if necessary.

IMPORTANT: The front axle housing must be in perfect lateral alignment with vehicle chassis before you proceed with installation.

- Once all adjustments are complete, fully tighten the Jam Nut (C) to prevent Adjustable Trackbar length from changing.

HINT: It may be easier to tighten Jam Nut with the Adjustable Trackbar removed from vehicle.

- Using a torque wrench, tighten mounting hardware at both ends of track bar to 125 ft-lbs.
- A professional steering alignment should be performed to correct toe position and to ensure vehicle meets proper alignment specifications.

Maintenance

Check torque specifications regularly.

Regular cleaning with pressurized water is recommended to maximize reliability.

© 2008 JKS Manufacturing, Inc & Aftermarketing, LLC
Revision Date 5/16/2008