

INSTALLATION INSTRUCTIONS

Flip-n-lock stereo cover and tray Part # 160

Please read and fill out the enclosed warranty registration card to activate your warranty.

Parts list



#4 Tray



#2 Base



#3 Door

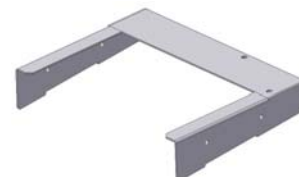

#1 Frame

Shipping Package



#8.1 (2) 1/4-20 x 7/8 Screws



#8.14 (4) 1/4-20 x 3/4" Screws



#8.13 (2) #8-32 x 3/4" Screws



#8.4 (8) 1/4 Washers



#8.5 (2) 1/4" Nylon Washers



#8.8 (2) #8 Washers



#8.3 (6) 1/4-20 Nylock nuts



#8.7 (2) #8-32 Nylock nuts

Tools Needed

- Flat head screwdriver
- 5/32" Allen wrench
- 3/32" Allen wrench
- (2) 7/16" Wrenches, socket & ratchet, or nut driver
- 11/32" Wrench, socket & ratchet or nut-driver
- 7MM Socket & ratchet or nut driver

Mounting Directions

Note: Vehicles equipped with the compass may need to be manually recalibrated to operate properly after installation, see owner's manual for simple instructions. It also automatically recalibrates over time.

1. Remove the factory plastic dash top #8.9. To do this pry up the end toward the front of the vehicle with a flat head screwdriver as illustrated about 1" behind the front of the dash top on both sides and then remove it. Use a barrier (like a piece of cardboard) to protect the dash when prying. (See Figure 1)
2. If the vehicle is equipped with the electrical box #8.10 unplug it and then unscrew it #8.12 from the factory dash top. (See Figure 1)
3. Remove the (4) factory screws #8.11 which are located under where the factory dash top was located. (2) Are securing the front dash panel and the other (2) are screwed in about 5" toward the windshield. Save these screws they will be reused. (See Figure 2)

4. Mount the #2 Base to the top of the dash using the (4) factory screws #8.11 removed in the above step. Be sure to insert the (2) vertical tabs between the plastic dash cover and the threaded inserts so the tabs are “sandwiched”. (See Figure 2)
5. If the vehicle is equipped with the electrical box #8.10 which was attached to the factory top mount it to the under side of the #1 Frame using (2) #8.13 screws, (2) #8.8 washers, and (2) #8.7 nuts. (See Figure 2)
6. If the vehicle is equipped with the electrical box #8.10 plug it back in. (See Figure 2)
7. Fasten #1 Frame to #2 Base using (4) #8.14 screws, (4) #8.4 Washers, and (4) #8.3 Nuts. The spacing between these parts for #4 tray can be adjusted when the screws are tightened. Slide in #4 Tray to test the fit; it should slide in easily but have no slop. Retighten as necessary for correct spacing. (See Figure 2)
8. Fasten #3 Door to #4 Tray using (2) #8.1 screws, (4) #8.4 washers, (2) #8.5 Nylon washers (Place between #3 & #4 parts), and (2) #8.3 Nuts. (See Figure 2)
9. Slide in Tray assembly and check the lock operation and fit. Adjust fit as necessary by loosening #8.14 screws adjusting and retightening. (See Figure 2)
10. Vehicles equipped with the compass may need to be manually recalibrated to operate properly after installation, see owner’s manual for these simple instructions. It also automatically recalibrates over time.

FIGURE 1

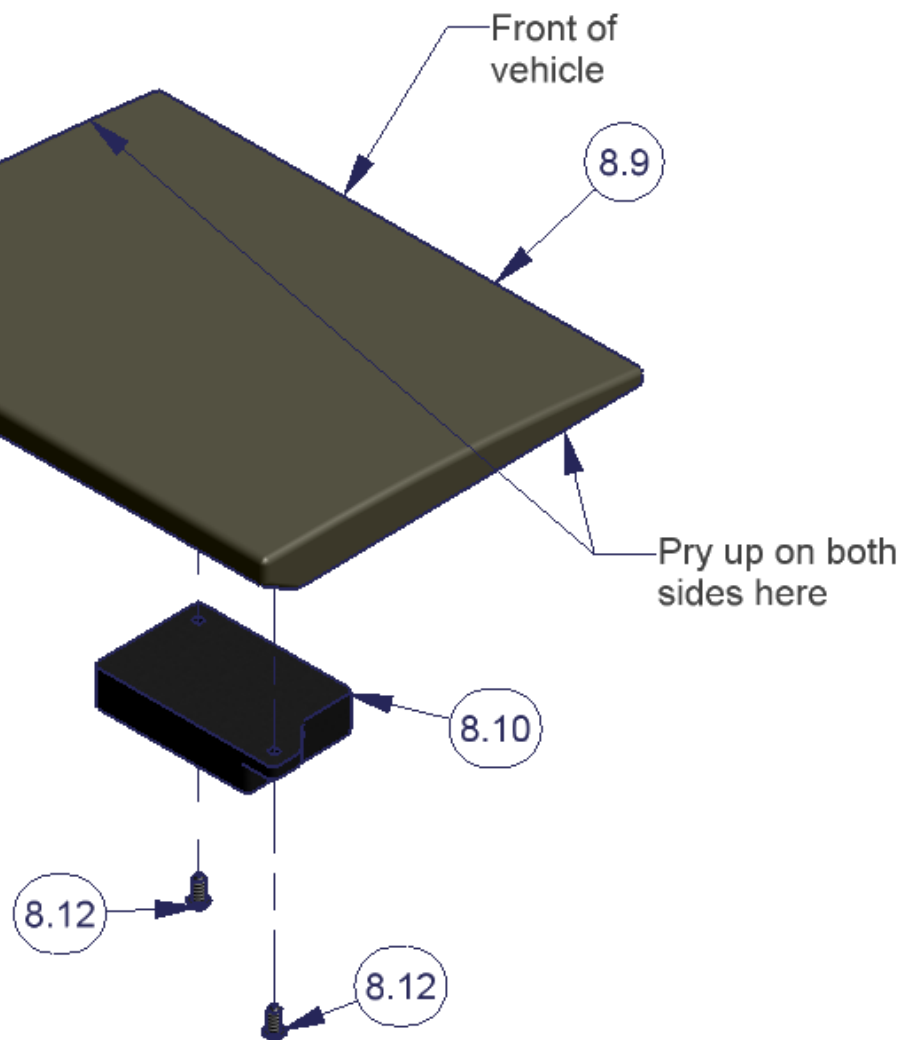
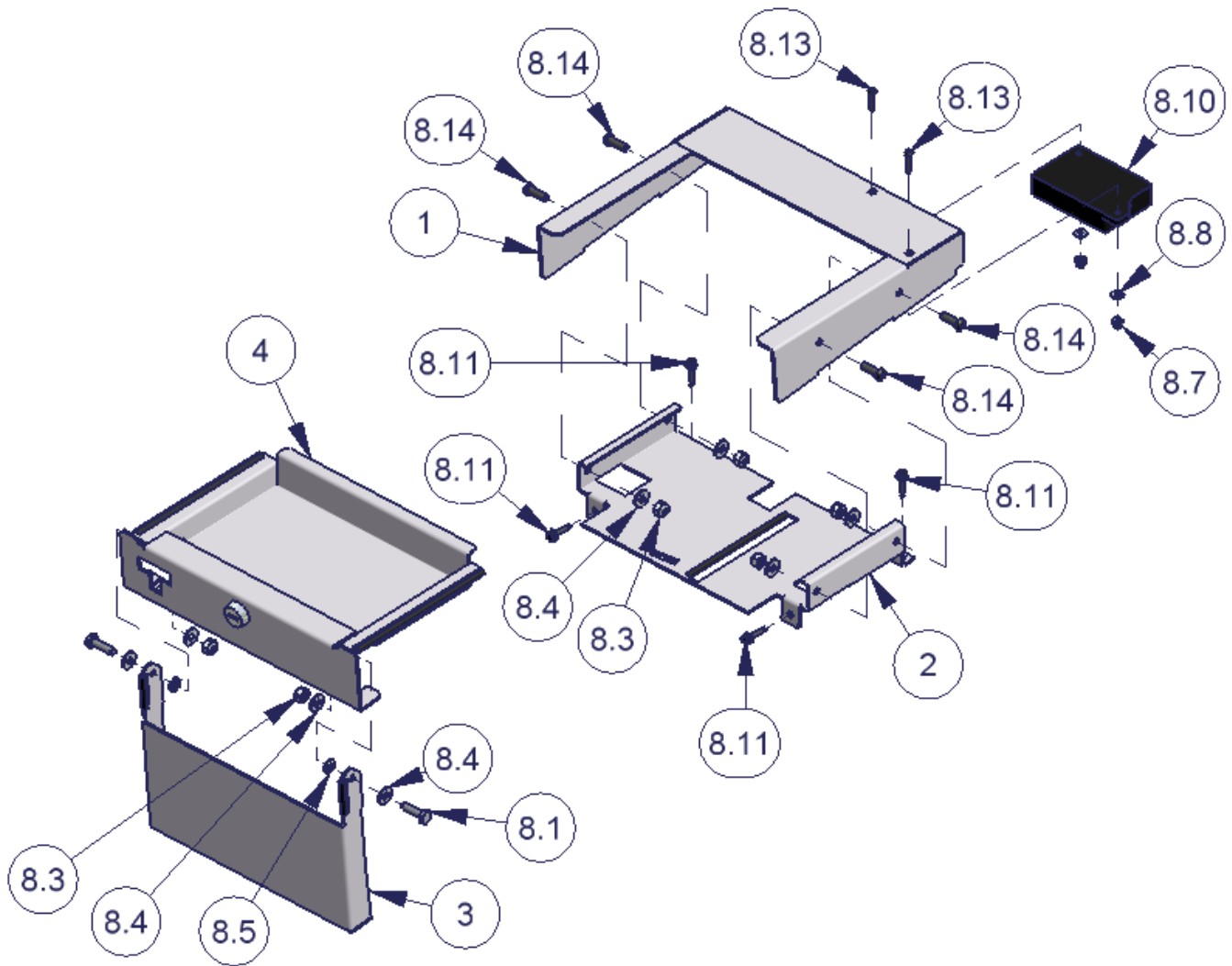

FIGURE 2



ATTENTION:

FREQUENT LUBRICATION IS NECESSARY ON THE LOCKING SYSTEM

The lock contains an "O" ring seal to protect the interior from dust and water. If this mechanism is not lubricated regularly it will become difficult to operate and it may not return to its home position preventing the key from operating the lock. If this happens lubricate the lock with a light lubricant such as silicone spray. The lock may have to be periodically disassembled and cleaned.

Call (970) 564-1762 for Technical Support