



FUEL INJECTION PERFORMANCE KIT  
**FIPK**

GENERATION II™

## INSTALLATION INSTRUCTIONS

### 57-1548

#### JEEP

2005-06 GRAND CHEROKEE

2006 COMMANDER

V8 4.7L

**NOTE:** This kit was not designed to fit vehicles with a body lift.

#### TOOLS NEEDED:

Ratchet  
Extension  
10mm Socket  
13mm Socket  
Flat Blade Screwdriver  
4mm Allen Wrench  
10mm Wrench  
7/16" Wrench

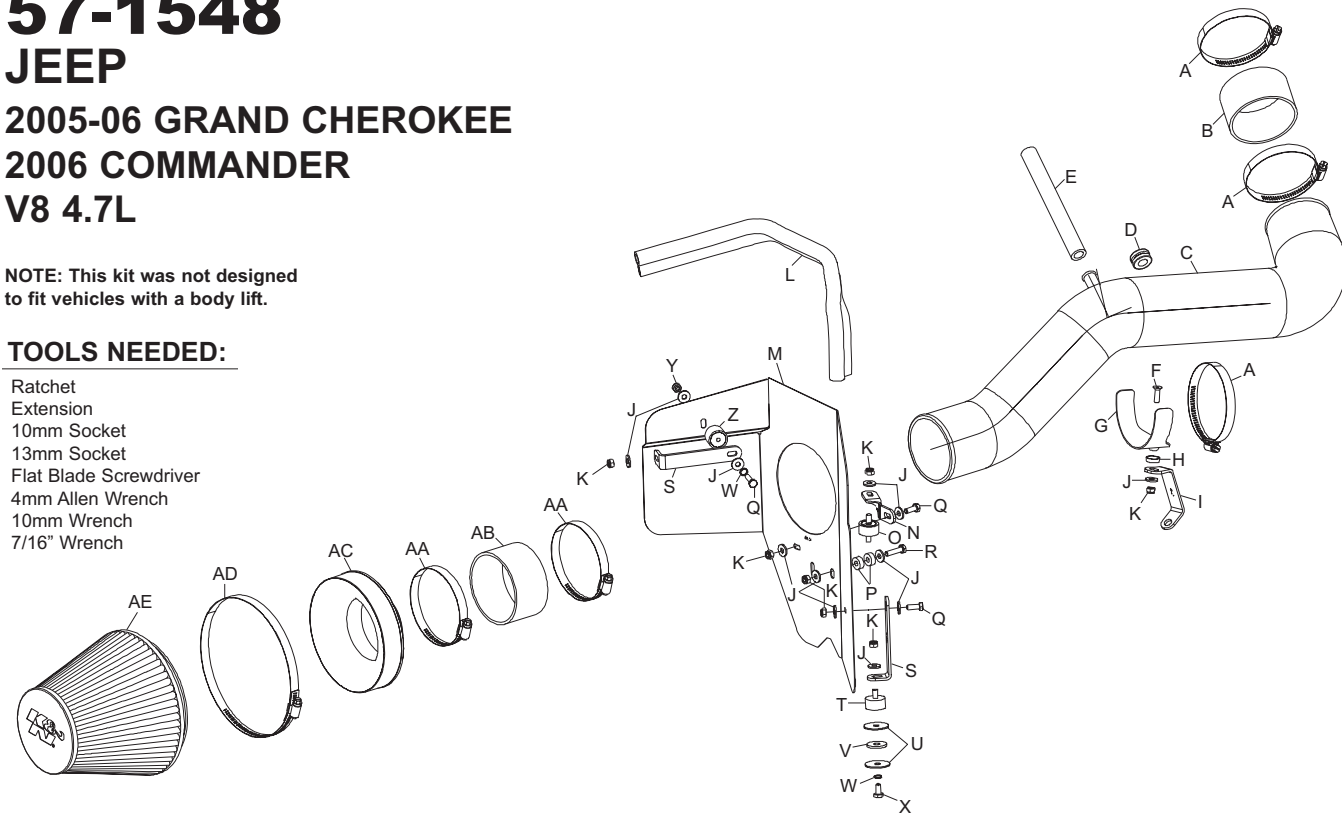

#### PARTS LIST:

Desc.	Part #	QTY.	
A	hose clamp #52	3	08610
B	hose; 3.25" id x 2", silicone	1	08690
C	intake tube (FM)	1	087185
D	grommet	1	08064
E	hose; 1/2" id x 7", black	1	08159
F	bolt; m6-1.00 f/h/a	1	08376
G	saddle bracket	1	078855
H	cup washer	1	08180
I	bracket; "C"	1	26614
J	washer; 1/4" id x 5/8" od, flat	12	08275
K	nut; 6mm nylock	7	07553
L	edge trim 17"	1	102469
M	heat shield	1	07321
N	bracket; twist	1	010117
O	stud; m6-1.00 m/m rubber mounted	1	07027
P	spacer; .625" od x .250" id x .250" l, alum	2	06555
Q	bolt; m6-1.00 x 16mm hex head	3	07703
R	bolt; m6-1.00 x 25mm hex head	1	07704
S	bracket; "L"	2	070952
T	stud; m6-1.00 m/f rubber mounted	1	070228
U	washer; 1.25" id x .28" id hole	2	08151
V	washer; 1" x .300" x .100"	1	21685
W	washer; 1/4" lock, zn	2	08198
X	bolt; 1/4"-20 x 1/2" hex head	1	08317
Y	nut; 1/4"-20 nylock	1	07517
Z	stud; 1/4"-20 m/f, 3/4" thk rub mnted	1	070226
AA	hose clamp #56	2	08620
AB	hose; 3.5" id x 2", silicone	1	08630
AC	filter adapter #380	1	21512
AD	hose clamp #104	1	08697
AE	air filter	1	RF-1048

#### TO START:

1. Turn the ignition OFF and disconnect the vehicle's negative battery cable.



2. Loosen the hose clamp, which secures the stock intake tube to the intake plenum, and disconnect the crank case vent hose from the air box lid.



3. Unclip the upper air box retaining clips and remove the upper air box and intake tube assembly as shown.



4. Disconnect the vacuum canister hose shown.



5. Using a small screwdriver, release the center holding pins in the six grill retaining clips shown.

**NOTE: FAILURE TO FOLLOW INSTALLATION INSTRUCTIONS AND NOT USING THE PROVIDED HARDWARE MAY DAMAGE THE INTAKE TUBE, THROTTLE BODY AND ENGINE.**



6. Remove the six grill retaining clips from the grill, then tilt the grill forward and lift to remove from the vehicle.



7. Pull the fresh air duct forward to disconnect it from the air box and then remove it from the vehicle.



8. Remove the air box mounting bolt shown.



9. Lift the lower air box and remove it from the vehicle as shown.

**NOTE: K&N recommends that customers do not discard factory air intake.**



10. Install the provided edge trim onto the heat shield as shown. **NOTE: Some trimming of the edge trim may be necessary.**

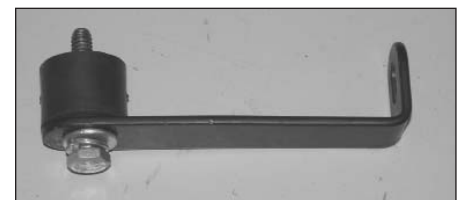

11. Install the 1/4"-20 male/female rubber mounted stud onto the "L" bracket (070952) with the provided hardware as shown.

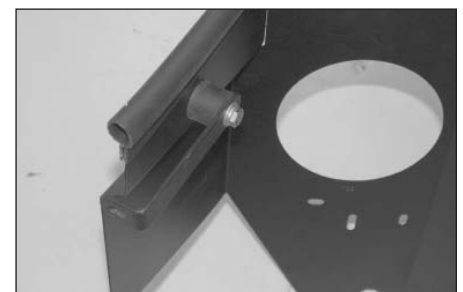

12. Install the bracket/rubber mounted stud assembly onto the heat shield as shown using the provided hardware.

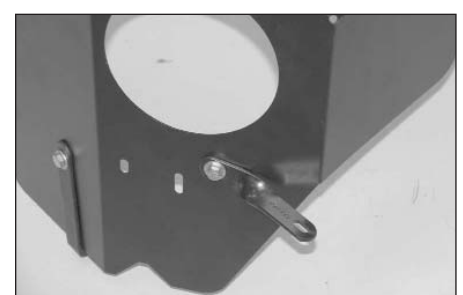

13. Install the twist bracket onto the heat shield as shown using the provided hardware.

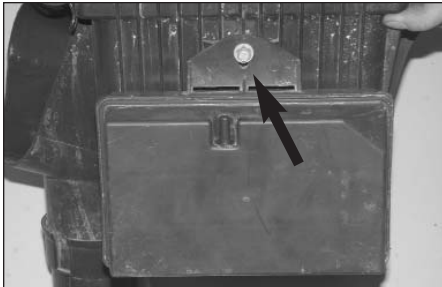

14. Remove the bolt which secures the vacuum reservoir to the air box and then remove the reservoir from the air box.



15. Using the provided spacer, install the vacuum reservoir onto the heat shield as shown.

**NOTE: Due to vehicle manufacturing tolerances, 2 spacers may be required.**



16. Remove the coolant reservoir-retaining nut and air box mounting grommet shown.



17. Using the two fender washers and one rubber washer, install the 6mm male/female rubber mounted stud onto the lower air box mount as shown.



18. Install the 6mm male/male rubber mounted stud onto the upper air box mount as shown.



19. Install the heat shield assembly into the vehicle and secure it to the mounting locations with the provided hardware.

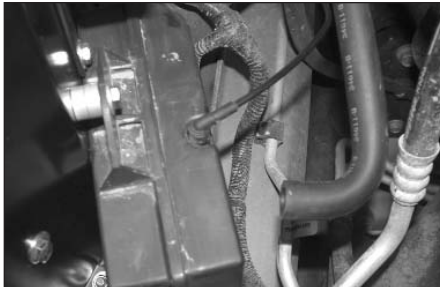

20. Reconnect the vacuum reservoir vacuum line.



20a. Disconnect the air temperature electrical connection.



20b. Remove the two bolts which secure the intake plenum to the intake manifold.



20c. Remove the intake plenum from the vehicle as shown.



21. Install the silicone hose (08690) onto the throttle body and secure with the provided hose clamp.



22. Install the saddle clamp onto the tube mounting bracket and secure with the provided hardware as shown.



23. Remove the Lower rear A/C mounting bolt shown.  
**NOTE: This bolt will be reused.**



24. Install the tube mounting bracket assembly onto the A/C compressor and secure with the factory-mounting bolt removed in step #23.



25. Rotate the air temperature sensor counter clockwise and remove the sensor from the stock intake plenum as shown.



26. Install the supplied rubber grommet into the K&N intake tube as shown.

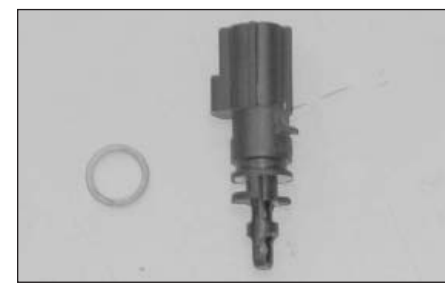

27. Remove the rubber sealing "O" ring from the air temperature sensor as shown.

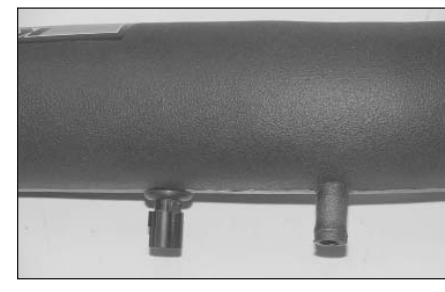

28. Install the air temperature sensor into the K&N intake tube as shown.



29. Install the K&N intake tube into the silicone hose at the throttle body and onto the saddle clamp, then secure with the provided hose clamps as shown.



30. Remove the factory crank case vent hose from the "T" fitting shown.



31. Install the supplied silicone hose onto the crank case vent "T" and connect the other end onto the K&N intake tube as shown.



32. Install the filter adapter into the air filter as shown, secure with the provided hose clamp.



33. Install the silicone (08630) onto the air filter assembly and secure with the provided hose clamp.



34. Install the air filter assembly onto the K&N intake tube as shown and secure with the provided hose clamp.

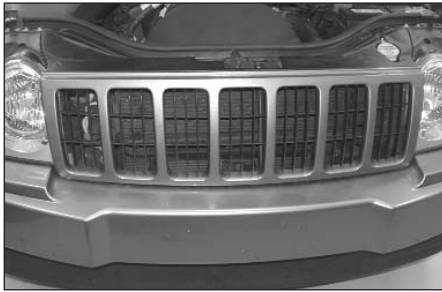

35. Reinstall the grill assembly with the factory retaining clips removed in step #5



36. Reconnect the vehicle's negative battery cable. Double check to make sure everything is tight and properly positioned before starting the vehicle.

37. The C.A.R.B. exemption sticker, (attached), must be visible under the hood so that an emissions inspector can see it when the vehicle is required to be tested for emissions. California requires testing every two years, other states may vary.

38. It will be necessary for all FIPK's to be checked periodically for realignment, clearance and tightening of all connections. Failure to follow the above instructions or proper maintenance may void warranty.

#### ROAD TESTING:

1. Start the engine with the transmission in neutral or park, and the parking brake engaged. Listen for air leaks or odd noises. For air leaks secure hoses and connections. For odd noises, find cause and repair before proceeding. This kit will function identically to the factory system except for being louder and much more responsive.

2. Test drive the vehicle. Listen for odd noises or rattles and fix as necessary.

3. If road test is fine, you can now enjoy the added power and performance from your kit.

4. K&N suggests checking the Air filter element periodically for excessive dirt build-up. When the element becomes covered in dirt (or once a year), service it according to the instructions on the Recharger service kit, part number 99-5050 or 99-5000.

\*FREE K&N DECAL To register your warranty, please see us online at [knfilters.com/register](http://knfilters.com/register). FREE K&N DECAL\*