

# JKS™

## Installation Instructions

Product: ACOS™

Part Number: PN 2570

Application: Jeep Wrangler JK, 2007+ (rear only)

### Welcome

CONGRATULATIONS on your purchase of a new JKS ACOS™ system! At JKS Manufacturing, we are committed to providing you with the best products available and your satisfaction is our first priority.

PLEASE READ these Installation Instructions carefully, and save them for future reference, as they contain important installation and maintenance information.

### Before You Begin...

1. Familiarize yourself with the supplied parts as illustrated in the column to the far right.
2. Thoroughly read all procedures to ensure you have the tools and experience necessary to complete this installation.
3. If you are not completely comfortable with any of the procedures described on the following pages, do not attempt this installation. Contact the JKS Technical Department at (308) 762-6949 to locate a qualified installation specialist in your area.

### Important

**MOST VEHICLES REQUIRE** additional parts or modifications to accommodate the immediate increase in ride height provided by the ACOS™ system.

**REAR CONTROL ARMS MUST BE** same length as original equipment arms to ensure proper bump stop alignment and coil spring clearance – see section 6 for details.

**DO NOT EXCEED** maximum range of adjustment – see illustration on page 3.

### Tools Required

- Hydraulic Floor Jack and Jack Stands
- Metric/Standard Socket Wrench Set
- Torque Wrench
- Transfer Punch (or equivalent)
- 1/4" and 3/8" Drill Bits
- 1/4" Allen Wrench
- Tape Measure
- Spray Lubricant (WD-40 or similar)
- Anti-Seize Lubricant
- Medium Strength Threadlocker
- Satin Black Spray Paint
- Coil Spring Compressor \*
- Plasma Cutter \*
- Grinding Wheel \*
- Welding Equipment \*
- Factory Service Manual (recommended)

\* Asterisk denotes tools that are not required for some applications. Thoroughly read instructions first to determine which tools will be required for your application.

### Parts

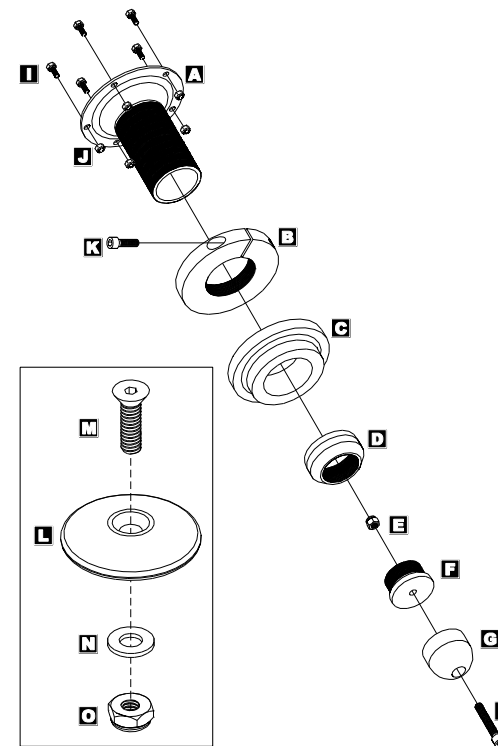

	DESCRIPTION	QTY
<b>A</b>	Main Body	2
<b>B</b>	Adjuster Ring	2
<b>C</b>	Isolator Pad	2
<b>D</b>	Bump Stop Adapter	2
<b>E</b>	10mm Locking Nut	2
<b>F</b>	Bump Stop Plug	2
<b>G</b>	Polyurethane Bump Stop	2
<b>H</b>	10mm x 55mm Cap Bolt	2
<b>I</b>	5/16" x 3/4" Bolt	10
<b>J</b>	5/16" Nylock Nut	10
<b>K</b>	3/8" x 1-1/4" Cap Bolt	2
<b>L</b>	Coil Spring Retainer	2
<b>M</b>	7/16" x 1-1/2" Flathead Socket Screw	2
<b>N</b>	7/16" Flat Washer	2
<b>O</b>	7/16" Nylock Nut	2

## Installation

### 1. REMOVE REAR COIL SPRINGS

- Remove the rear coil springs per the factory service manual instructions for your vehicle. **HINT:** A coil spring compressor is useful for removal.

Depending on the application, it may be necessary to completely or partially remove any of the following components before spring can be free from upper mount.

- Shock Absorber
- Swaybar
- Track Bar
- Emergency Brake Cable
- Brake Line
- ABS Wire

### 2. PREPARE UPPER SPRING MOUNT

- Remove the rubber isolator pad from the upper coil spring mount on the chassis.
- Locate the small hole in the upper spring mount that was previously concealed by the rubber isolator pad.
- Position the flange end (concave) of the Main Body (A) over the center portion (convex) of the upper spring mount as illustrated below.

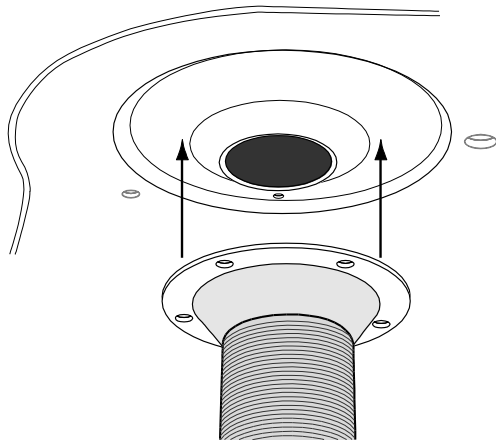

- Rotate the Main Body (A) until one of the holes in the mounting flange aligns with the factory hole in the upper spring mount.
- Using the Main Body (A) as a template, accurately mark the four remaining hole locations on the upper spring mount. **HINT:** A transfer punch or similar tool is useful for marking hole locations.
- Remove the Main Body (A) and drill a pilot hole at each marked location using a 1/4" drill bit. Enlarge each hole with a 3/8" drill bit.

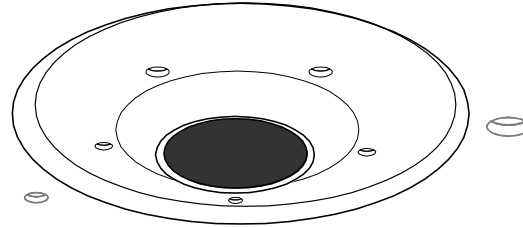

- Paint any exposed metal on the upper spring mount to prevent corrosion.

### 3. INSTALL ACOS™ ON UPPER SPRING MOUNT

- Reposition the Main Body (A) of ACOS over the center portion of the upper spring mount so that all five mounting holes are in alignment.
- Insert a 5/16" x 3/4" Bolt (I) through each mounting hole. **HINT:** Bolts must be inserted from above upper spring mount so that bolt threads point down as illustrated below.

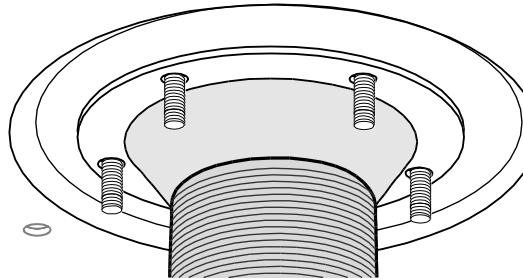

- Loosely thread a 5/16" Nylock Nut (J) onto each 5/16" x 3/4" Bolt (I).
- Once all five bolts have been installed, tighten the 5/16" Nylock Nuts (J) to 40 ft-lbs. using a torque wrench.

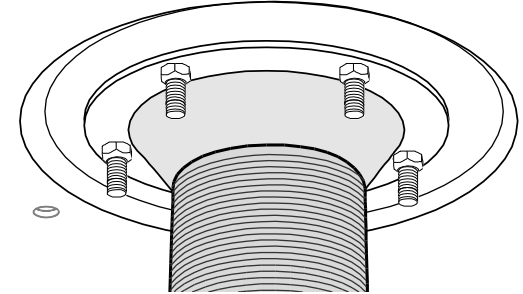

**4. SET ADJUSTER RING FOR DESIRED RIDE HEIGHT**

- Apply spray lubricant to threaded portion of Main Body (A).
- Install Adjuster Ring (B) by threading it onto the Main Body (A).
- Slide Isolator Pad (C) onto Main Body (A) until flush with Adjuster Ring (B).

**IMPORTANT: Vehicle ride height is determined by measuring the distance between the top of Main Body and bottom of Isolator Pad, and then subtracting 3/8" (0.375 in.).**

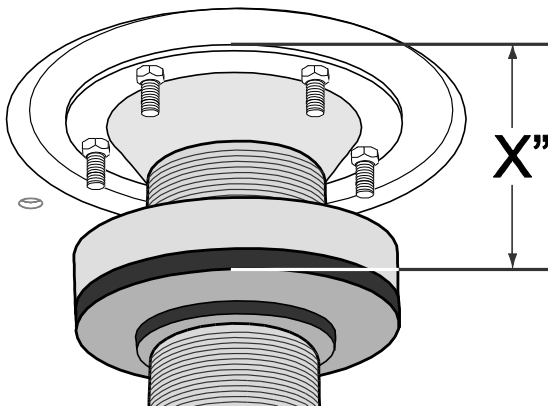

**$X'' - 3/8'' = \text{RIDE HEIGHT}^*$**

\* Represents increase in ride height over OE suspension



**WARNING**

**DO NOT EXCEED  
MAXIMUM RANGE OF ADJUSTMENT**

**ADJUSTMENT RANGE \***

**MINIMUM: 2" (2.0 in.)  
MAXIMUM: 4" (4.0 in.)**

- Rotate Adjuster Ring (B) to desired position and tighten the recessed 3/8" x 1-1/4" Cap Bolt (K) to lock in place.

**5. INSTALL BUMP STOP ON THREADED TUBE OF ACOS™**

- Apply a drop of thread locking compound to bottom few threads of Main Body (A).
- Install Bump Stop Adapter (D) onto Main Body (A) and tighten by hand until snug.

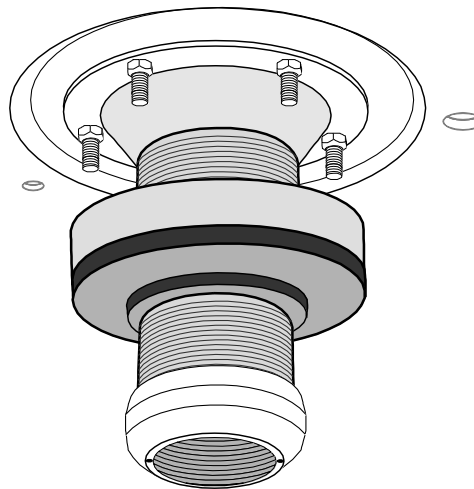

- Insert the 10mm x 55mm Cap Bolt (H) into the recessed hole in Polyurethane Bump Stop (G) and through the hole in the bottom of the Bump Stop Plug (F).
- Secure the Polyurethane Bump Stop (G) to the Bump Stop Plug (F) by installing the 10mm Locking Nut (E).

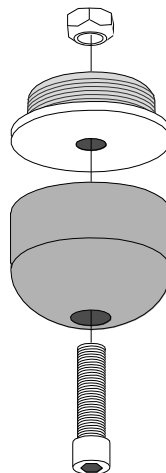

- Slowly tighten 10mm x 55mm Cap Bolt (H) until the sides of the Polyurethane Bump Stop (G) begin to bulge. *Do NOT overtighten!*
- Apply anti-seize lubricant to threads of Bump Stop Plug (F).
- Install Bump Stop Plug (F) with Polyurethane Bump Stop (G) by threading the assembly completely into the Bump Stop Adapter (D). Tighten by hand until snug.

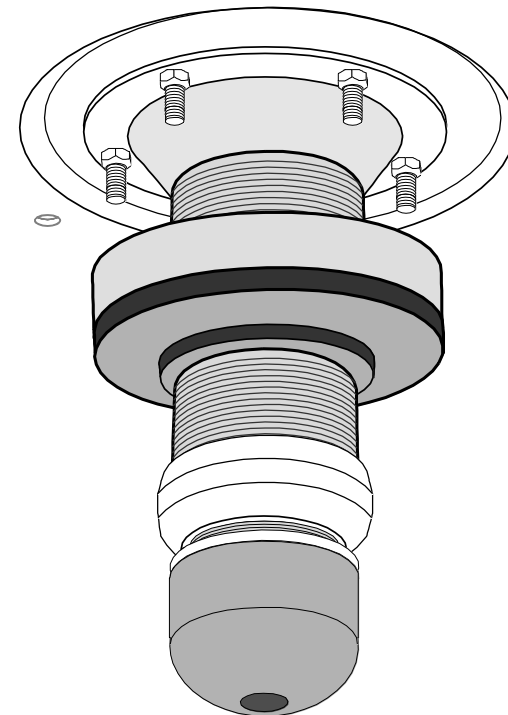

## 6. CHECK BUMP STOP ALIGNMENT

Before the rear coil springs are re-installed, it is important to make sure the lower spring post will properly align with the Bump Stop (G) during suspension compression.

- Carefully raise the axle housing with a hydraulic jack until the Bump Stop (G) contacts the lower spring post. **HINT:** A slight variation in alignment is acceptable because the supplied Coil Spring Retainer (L) will increase the Bump Stop (G) landing surface.

**IMPORTANT:** If the Bump Stop (G) does not contact the lower spring post, it may be necessary to rotate the lower spring mount on the axle housing. Typically this is only required if longer-than-stock control arms have been installed.

Rotating the lower spring mount requires cutting and welding and should only be performed by a qualified fabricator. Failure to perform this modification correctly can cause irreversible damage to the product and vehicle.

For any questions regarding this procedure, contact JKS Manufacturing immediately for technical assistance.

JKS Technical Department	
Phone	(308) 762-6949
E-mail	tech@jksmfg.com

## 7. RE-INSTALL REAR COIL SPRINGS

- Re-install the rear coil springs per the factory service manual instructions for your vehicle. **HINT:** A coil spring compressor is useful for installation.
- Also re-install any of the components that were removed during the REMOVE REAR COIL SPRINGS section of this installation.



## ATTENTION INSTALLER

### IMPORTANT NOTE REGARDING SHOCK ABSORBERS

**Make sure the shock absorbers accommodate any changes in ride height. It may be necessary to install new shocks that are the correct length for your application.**

## 8. INSERT COIL SPRING RETAINER

In addition to keeping the coil springs attached to the lower spring mounts, the supplied Coil Spring Retainers (L) also provide a larger surface for the bump stops to contact

- Locate the 5/8" hole in the center of the lower spring mount on the rear axle.
- Place Coil Spring Retainer (L) inside the spring by sliding it between the coils. Make sure flat side of Coil Spring Retainer faces down.
- Position Coil Spring Retainer (L) directly on the lower spring mount as illustrated.

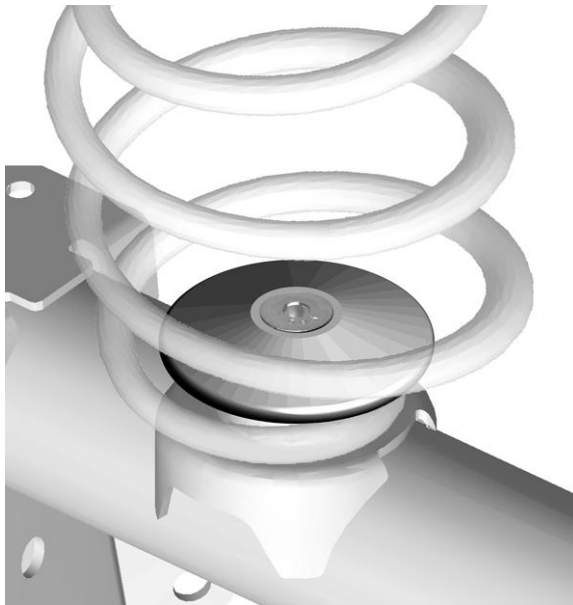

## 9. SECURE SPRING RETAINER TO LOWER SPRING MOUNT

- Insert 7/16" x 1-1/2" Flathead Socket Screw (M) into tapered hole in center of Coil Spring Retainer (L), and through the hole in the lower spring mount.
- From beneath spring mount, slide a 7/16" Flat Washer (N) onto threads of Flathead Socket Screw (M) and install the 7/16" Nylock Nut (O).
- Secure the Coil Spring Retainer (L) to the lower spring mount by tightening the mounting hardware. Use a 1/4" Allen Wrench to prevent the 7/16" x 1-1/2" Flathead Socket Screw (M) from spinning, and tighten the 7/16" Nylock Nut (O) to 50 ft-lbs.
- Make sure the Coil Spring Retainer (L) is perfectly flat against the lower spring mount, and coil spring is secure.

## Operation

### Ride Height Adjustments

Future ride height adjustments should be made with **NO LOAD** on the front coil springs, and the suspension at **FULL DROOP**.

**NEVER TURN** Adjuster Ring (B) while under tension and **ALWAYS APPLY SPRAY LUBRICANT** to threads of Main Body (A) before adjusting.

## Maintenance

Regular cleaning with pressurized water is recommended to maximize ease of operation and reliability.

In addition, the Bump Stop Adapter (D) has two 1/8" drainage holes that evacuate any water collected inside the upper spring retainer. Periodically check for blockages and clear the drainage holes if necessary.

© 2008 JKS Manufacturing, Inc & Aftermarketing, LLC  
Revision Date 2/29/2008