

# MILE MARKER

**ABUSED WORLD WIDE**

2121 Blount Road  
Pompano Beach, FL 33069  
1-(800)-886-8647 • 1-(954)-782-0604  
[www.milemarker.com](http://www.milemarker.com)

## Installation and Operator's Manual:

ATV Winch System:  
PE 2.5 (PN 77-50105)  
VMX 2.5 (PN 76-72105)



# Table of Contents:

<b>Safety Warnings &amp; Precautions.....</b>	<b>3</b>
<b>Winching Tips &amp; Techniques.....</b>	<b>6</b>
<b>Getting Started:</b>	
<b>Unpacking Your Winch.....</b>	<b>8</b>
<b>Winch Mounting.....</b>	<b>8</b>
<b>Wiring Instructions.....</b>	<b>9,10</b>
<b>Operation Instructions.....</b>	<b>11</b>
<b>Maintenance.....</b>	<b>14</b>
<b>Troubleshooting.....</b>	<b>14</b>
<b>Parts List.....</b>	<b>15,16</b>
<b>Warranty.....</b>	<b>18</b>



# Safety Warnings

When using this winch, safety precautions should always be followed to reduce the risk of personal injury and damage to the winch.

1) **LEARN TO USE YOUR MILE MARKER WINCH:**

a. After winch has been installed, take some time and practice using it so you will be familiar with ALL OPERATIONS. Periodically check the winch installation to ensure that all bolts are tight.

b. To ensure proper operation, carefully inspect for any damaged parts before operating the winch.

2) **KEEP WINCHING AREA CLEAR:**

Do not allow people to remain in the area during winching operations. Do not step over a taut wire rope or allow anyone else to do so. Due to the possibility of cable failure, direct all personnel to stand clear of any possible pathway. A snapped cable could cause winch failure, injury or death. Keep proper footing and balance at all times. Do not reach over or across the winch and/or pulling cable while the winch is in operation.

3) **INSPECT WIRE ROPE AND EQUIPMENT FREQUENTLY:**

The wire rope should be inspected for damage that could reduce its breaking strength. A frayed rope with broken strands should be replaced immediately. Always replace the rope with a rope that is rated to sustain any load that the winch is capable of pulling. Any substitute must be IDENTICAL in strength, quality, lay and stranding to the Mile Marker cable originally supplied.

4) **WORKING AREA CONDITIONS:**

Keep the working area well lit. Do not use this winch in the presence of flammable gases or liquids.

5) **KEEP CHILDREN AWAY:**

Keep children away from working area. Never let children operate the winch.

6) **DRESS PROPERLY:**

Do not wear loose clothing or jewelry as they can be caught in moving parts. Protective, electrically non-conductive clothes and non-skid footwear is the only type of clothing you should be using when operating the winch. Wear restrictive hair covering to contain long hair.

7) **USE LEATHER GLOVES:**

When handling or rewinding wire rope always use hand protection to eliminate the possibility of cuts caused by burrs & slivers from broken strands.

8) **DRUM ROPE:**

Always make sure that there are at least 5 complete turns of rope left on the drum before winching.

9) **KEEP HANDS AND FINGERS CLEAR OF WIRE ROPE AND HOOK WHEN OPERATING WINCH:**

Never put your finger through the hook when reeling in the last few feet. If your finger should become trapped in the hook or rope, you could lose your finger. Never guide a wire rope under tension onto the drum with your hand.

10) **NEVER HOOK THE ROPE BACK ONTO ITSELF:**

Hooking the rope back onto itself creates an excessive strain that could break individual strands; this, in effect, weakens the entire wire rope.

11) **KEEP PULLING DURATIONS AS SHORT AS POSSIBLE:**

The winch is designed for intermittent use and cannot be used in constant duty applications. Do not pull more than one minute at or near rated load. If the motor becomes too hot to touch, stop and let it cool off for a few minutes. If the motor stalls, cut off the power immediately.

# Safety Warnings-Cont'd

When using this winch, safety precautions should always be followed to reduce the risk of personal injury and damage to the winch.

12) **DO NOT OVERLOAD:**

For your safety and efficient performance, always use this winch at or under its rated capacity for your safety and for better performance. Do not use inappropriate attachments in an attempt to exceed its rated capacity.

13) **AVOID CONTINUOUS PULLS FROM EXTREME ANGLES:**

This will cause the rope to pile up at one end of the drum. When possible, please get the rope as straight as possible to the direction of the object.

14) **NEVER OPERATE THE WINCH WITHOUT THE ROPE FAIRLEAD FITTED:**

Operator injury or winch damage can result if a fairlead is not installed.

15) **STAY ALERT:**

Watch what you are doing. Use your common sense. Do not use this winch when you are tired, stressed or **WHEN UNDER THE INFLUENCE OF DRUGS, ALCOHOL OR MEDICATION.**

16) **DISCONNECT SWITCH:**

Unplug switch when not in use.

17) **REPLACEMENT PARTS & ACCESSORIES:**

When servicing, use only identical replacement parts. Usage of any other parts will void the warranty. Approved accessories are available from your local distributor.

# Precautions

When using this winch, safety precautions should always be followed to reduce the risk of personal injury and damage to the winch.

- 1) Keeps hands and body away from Fairlead (cable intake slot) when operating.
- 2) Secure vehicle in position before using winch.
- 3) Do not exceed winch load weight capacity (see Winch Specifications).
- 4) Be certain winch is properly bolted to a structure (or vehicle) that can hold the winch load.
- 5) Always use proper couplings when connecting winch cable hook to load.
- 6) Do not lift items vertically. The winch was designed for horizontal use only.
- 7) Do not overload the winch (see Model Specifications). It will do the job better at the load it was intended.
- 8) Do not use inappropriate attachments to extend the length of the winch cable.
- 9) NEVER LIFT PEOPLE OR HOIST LOADS OVER PEOPLE.
- 10) Never come in between the winch and the load when operating.
- 11) Do not apply load to winch when cable is fully extended. Keep AT LEAST 5 FULL TURNS of cable on the drum.
- 12) After moving an item with the winch, secure the item. Do not rely on the winch to hold it for an extended period.
- 13) Examine winch before using. Components may be affected by exposure to everyday weathering, chemicals, salts, and rust.
- 14) Never fully extend cable while under load. Keep 5 COMPLETE TURNS of cable around the winch drum.
- 15) When loading a boat into a trailer without reel or side hull rollers, make sure the trailer is submerged in the water when the boat is loaded by the winch. Attempting to drag the boat on to the trailer while on land can cause winch failure and possible injury.
- 16) Never operate winch if cable shows any signs of weakening, is knotted or kinked.
- 17) Winch does not have a locking mechanism. Secure load after moving.
- 18) Do not cross over or under the cable while it is in process of loading.
- 19) Do not move vehicle with cable extended and attached to load to pull it. The cable could snap.
- 20) Apply blocks (such as a wheel choke) to vehicle when parked on an incline.
- 21) Re-spool cable properly.

# Winching Tips & Techniques

## WINCHING TIPS AND USE OF A SNATCH BLOCK

- Use OEM tow hooks, recovery eyes or a clevis mount for attachment of a tow strap or winch cable. Warning: Never use a ball and /or ball mount as an anchor point for tow strap or winch cable. Severe personal injury or death could occur.
- Always heed all winch manufacturer's recommendations, cautions, and warnings.
- Attach return cable to tow hook or recovery eye when using a snatch block. Always use a clevis to secure snatch block to strap, or severe damage could occur to persons and vehicle. (See Figure Below). Caution: Never attach return cable to winch mount. This may overload winch mount

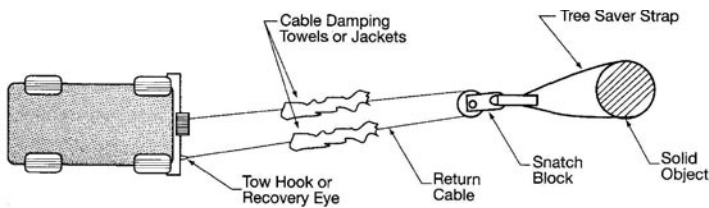

## RATING

For maximum line pull rating, winch cable direction must not exceed:

1. 15° angle up or down from horizontal (See Figure Below).
2. 45° angle left or right from straight ahead (See Figure Below). Caution: Exceeding the maximum line pull rating may overload winch, winch mount, and/or front mounted

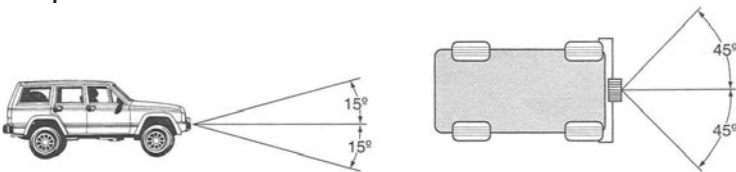

## SAFETY TIPS

- NEVER DISENGAGE CLUTCH LEVER WHEN THERE IS A LOAD ON THE WINCH. Mile Marker electric winches utilize an automatic load holding brake, therefore no adjustment to clutch is needed to maintain load.
- Store the remote control cord in a safe place when not in use to prevent use by children or other unauthorized persons who could injure themselves or others or damage the controls.
- Do not operate winch under the influence of drugs, alcohol, or medications.
- Isolate winch before putting hands in or around the fairlead or wire rope drum (The Danger Zone).
- DO NOT OVERLOAD YOUR WINCH. Do not maintain power to the winch if the drum stops. Overloads can damage the vehicle, winch or winch rope and create unstable operating conditions.
- It is recommended to lay a heavy blanket or jacket over the rope about halfway along to the hook attachment. If a rope failure should occur, the weight of the cloth will act as a damper and help prevent the broken rope from whipping (See Figure Below). Remember to move the blanket or jacket as winching proceeds, but halt winching when doing so. Partially raising the hood of the vehicle will also give a measure of protection to its occupants from broken rope or cable, consistent with sufficient forward visibility for the operator.

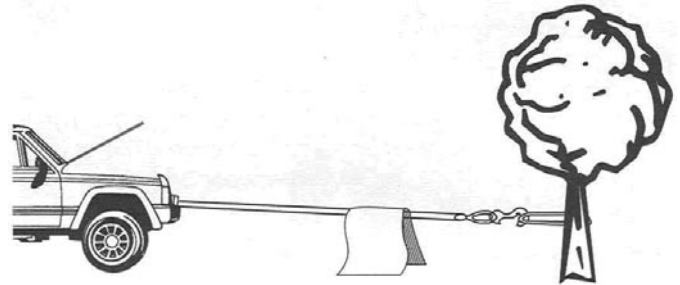

# Winching Tips & Techniques

## SELF-RECOVERY

1. Always attempt to get the cable as straight as possible to the direction of the vehicle. It is acceptable to start a pull at an angle if it is obvious that the vehicle will turn towards the hook anchoring point. Turning the steering wheel will assist the process. It is recommended that the driver is in the vehicle.
2. Make sure hand brake and foot brake are free and that the transmission is in neutral.
3. When the driver's attempt to regain vehicle traction is successful, he or she should be careful not to overrun the cable and risk the possibility of it being trapped under the vehicle.
4. DO NOT move your vehicle in reverse to assist the winch. The combination of the winch and vehicle pulling together could overload the cable and winch itself.

## USE OF A PULLEY BLOCK OR SNATCH BLOCK

Vehicle self-recovery using the pulley block attached to the anchor point for direct pull. In this instance the vehicle becomes the "load" and the actual pulling power on the vehicle will be double at half winch rope speed. Never connect wire rope or hook back to winch mount!

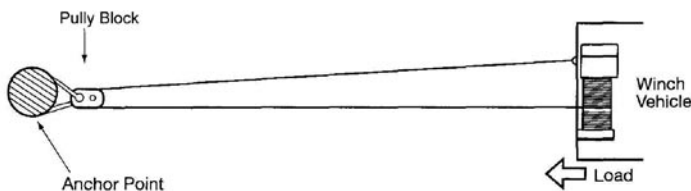

Below: Direct pull on load using the winch vehicles as the anchor with pulley block attached to the load.

The most important aid to successful winching (after the winch) is the pulley block, which can be used to increase the pulling power of the winch or for indirect pulls. Pulley blocks can be used in two modes. First mode is attached to the load and second is secured to an anchor point.

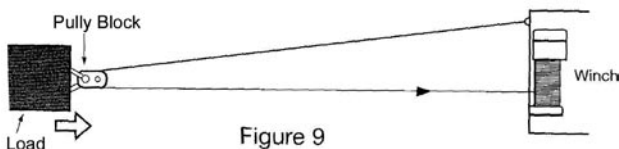

Below: Indirect pull necessitated by obstructions or soft ground. Pulley block attached to load using a suitable anchor point. Note the angled direction taken by the load and subsequent angle of rope feedback on the winch drum (extreme example shown). There may be unavoidable circumstances requiring this mode, though in general it is not recommended unless applied in stages by moving the anchor point or vehicle to avoid the sharp angled rewind on the winch drum. The actual load pulling power and rope speed will depreciate with any increased angle between the ropes.

The anchor point, when used must be secure, using a tree, another vehicle or any firm structure to which a pulley block can be used to your advantage.

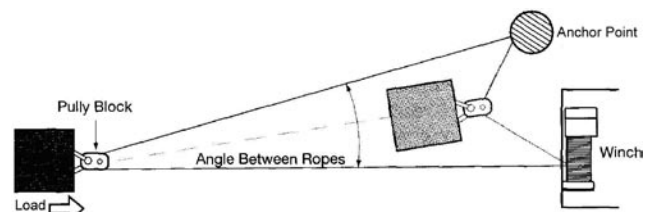

## USE OF A NYLON SLING AND SHACKLE

- A shackle should always be used when attaching winch hooks to nylon slings. NOTE: The shackle must pass through both eyes of the sling. The safe working load of the nylon sling is based on the use of both eye ends.

Never use the cable or hook to connect directly to the nylon sling.

## USE OF GLOVES

- When handling or rewinding the cable always use gloves to eliminate the possibility of cuts caused by burrs and broken strands. Inspect cable and equipment frequently. The cable should be replaced immediately if any sign of burrs or broken strands are evident. A frayed cable with broken strands should be replaced immediately. Always replace the cable with a Mile Marker recommended replacement part. Any substitution must be IDENTICAL in strength, quality, lay and stranding. Never hook the cable back onto itself. Hooking the cable back onto itself creates an unacceptable strain, breaking individual strands which in turn weakens the entire cable. Use a sling. Avoid continuous pulls from extreme angles as this causes cable to pile up at one end of the drum.



# Getting Started

## Unpacking Your Winch

•Unpack your new Mile Marker winch and ensure that all the parts are included by referring to parts list and exploded view drawings provided in this manual.

**NOTE:** If you find any missing or broken parts, please call Mile Marker as soon as possible at the number present on the cover page of this manual.

## Mounting Options

When installing a winch, your installation may vary from the manual diagrams and instructions included here due to physical vehicle differences. Always disconnect the battery from the vehicle to before starting installation.

If you choose NOT to use an ATV mounting kit you may be required to drill holes in a structural support on the ATV. Be sure the location will be strong enough to support the rated pulling force of the winch. **DO NOT DRILL INTO OR NEAR WIRING OR GAS TANK!**

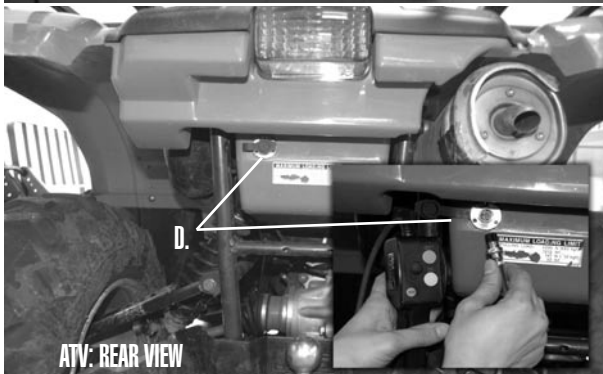
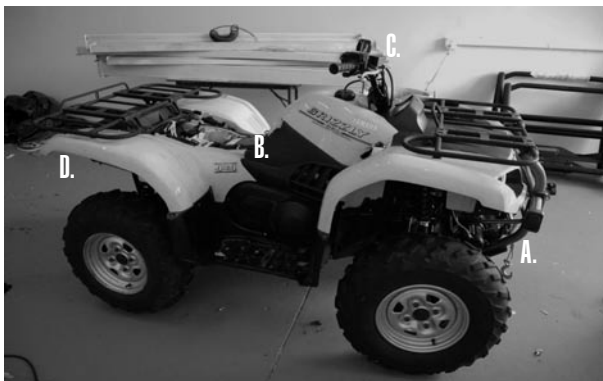

1-1: Mounting Points used in this installation: (A) Winch and Mount, (B) Under Seat Control Box Mounting, (C) Handlebar Pendant Mount, (D) Remote Pendant Receiver Location

## Winch Mounting

**NOTE:** Mile Marker recommends the use of its mounting systems for proper winch installation and optimum winch performance. However, when not using Mile Marker Mounting System, ensure that the mounting platform is strong enough to meet the maximum rated load of the winch in use.

Your Winch should be aligned and secured to a solid part of the vehicle (front or rear) where the full rated load will be evenly distributed.

**CAUTION:** It is essential that the mounting surface be flat and the winch is mounted such that the three major sections (Gear housing end, drum and motor end) are in proper alignment.

1. Install the mounting kit or prepare a flat and secure location on the ATV for the winch. The winch mount kit has it's own instructions for the intended ATV.

2. Position the winch over the mount and check for operation of the clutch lever to frame clearance. Check for tire to winch clearance. If ok, continue on to the next step.

3. Secure the winch to the mounting bracket or surface chosen with the correct hardware.

**NOTE:** Make sure the winch mounting bolts and winch hardware has been checked for proper torque. Sometimes it may be necessary to remove the cable from the winch drum to install the mounting hardware or roller/hawse fairlead. All Mile Marker Mounting Systems come fairlead ready. If you are using any other mounting platforms, drill two holes for the roller fairlead installation. Position the holes such that the fairlead opening hole stretches from the circumference of the drum to the end of the maximum permissible layers on the drum in the direction cable is being rolled.



# Wiring Instructions: VMX 2.5

**NOTE:** Be sure to mount control box in a location that: (a) does not interfere with any vehicle's moving / functioning parts, and (b) use electrical cables with similar or better specifications as that provided by Mile Marker if a substitution is required. When mounting box, Mile Marker recommends that the aluminum fins on housing FACE UP, at a skyward orientation, to best dissipate heat.

**CAUTION:** Battery cables should not be drawn taut; leave some slack for cable movement. Also, ensure that they are routed properly with out any interference with the vehicular components that could potentially damage the cable or cause electrical short.

Long battery cable runs may have significant voltage drops that may cause the winch motor controller to not operate properly.

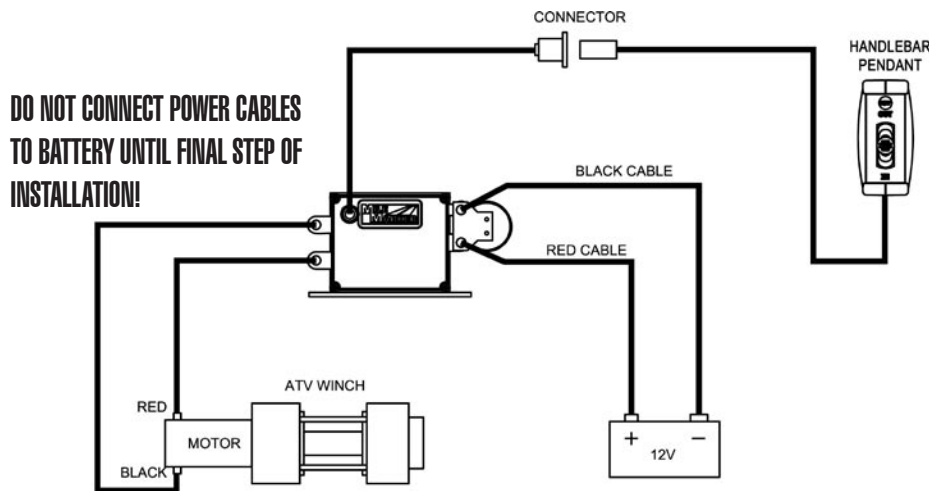

**VMX 2.5 Wiring Schematic with Handlebar Control**

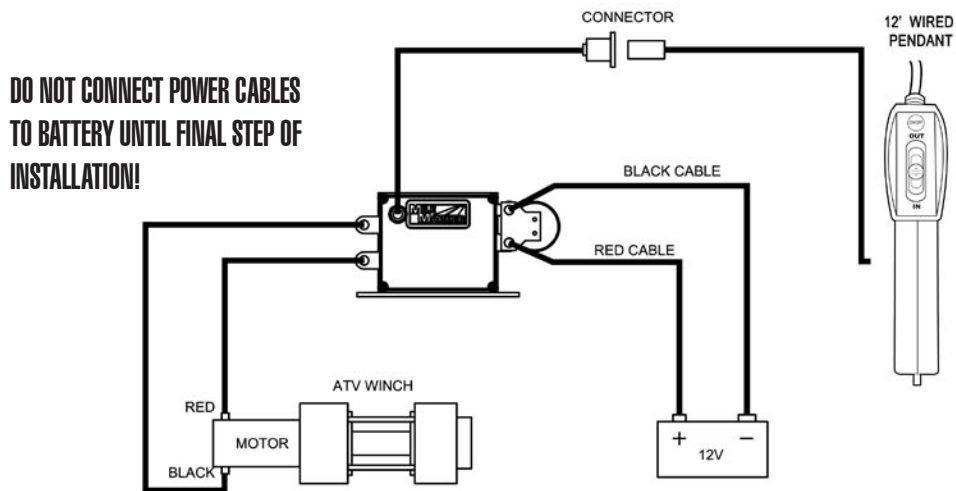

**VMX 2.5 Wiring Schematic with 12' Remote**

# Wiring Instructions: PE 2.5

**NOTE:** Be sure to mount control box in a location that: (a) does not interfere with any vehicle's moving / functioning parts, and (b) use electrical cables with similar or better specifications as that provided by Mile Marker if a substitution is required.

**CAUTION:** Battery cables should not be drawn taut; leave some slack for cable movement. Also, ensure that they are routed properly with out any interference with the vehicular components that could potentially damage the cable or cause electrical short.

Long battery cable runs may have significant voltage drops that may cause the winch motor controller to not operate properly.

**DO NOT CONNECT POWER CABLES TO BATTERY UNTIL FINAL STEP OF INSTALLATION!**

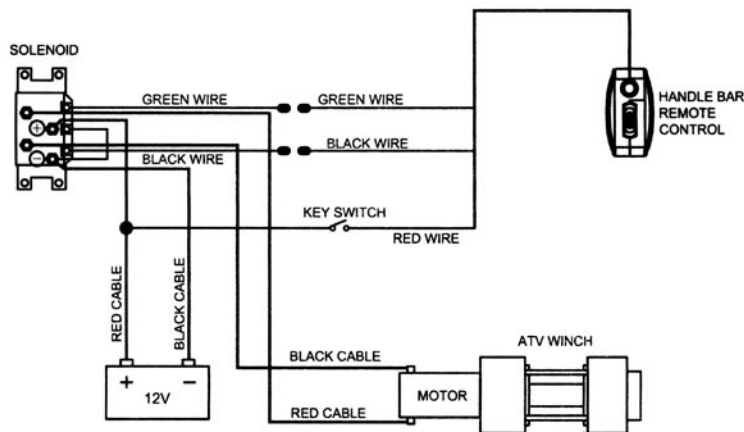

**PE 2.5 Wiring Schematic with Handlebar Control**

**DO NOT CONNECT POWER CABLES TO BATTERY UNTIL FINAL STEP OF INSTALLATION!**

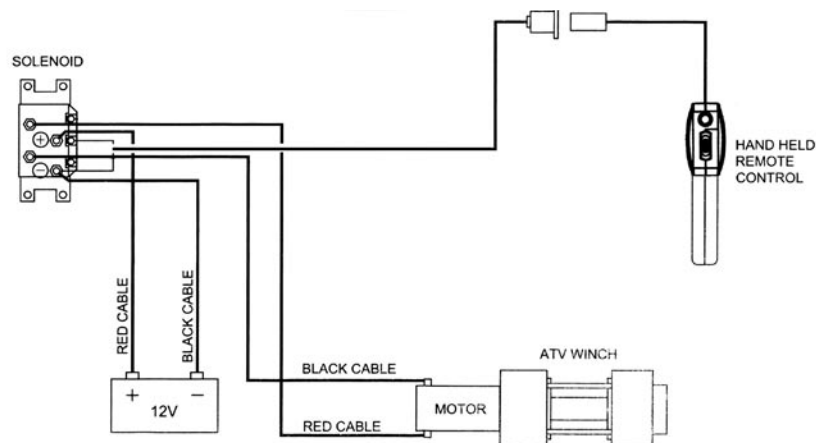

**PE 2.5 Wiring Schematic with 12' Remote**

# Winch Operation

## Function Testing

After checking all connections in accordance to installation instructions prior, connect power cables to vehicle's battery. Attach Black Cable to Negative (-) Battery Terminal and secure, followed by attaching the Red Cable to Positive (+) Battery Terminal.

1. Before testing the winch, turn the clutch handle to the "Freespool" position. Always wear heavy gloves when handling winch cable. Using a Mile Marker hook strap, pull about two feet of cable off the winch drum, and place the clutch handle in the "Engaged" position (fig. 3-1).

2. Turn on the winch pendant by pressing the red "On/Off" Button. The pendant will illuminate blue, indicating power to the Control Pendant (fig. 3-2).

3. Toggle the Joystick "down" to retrieve line. The Pendant's LED will turn Green. When using the 12' Wired Pendant, you can also press the Green "IN" button for the same retrieval function (fig. 3-3). Winch cable will spool in on drum.

**NOTE:** If cable is spooled "Out" while pressing the "IN" function, please refer to Figure 2-5, and switch power cables to opposite studs on motor.

4. Toggle the Joystick "up" to Power Out winch cable. When using the 12' Wired Pendant, you can also press the Red "OUT" button for the same Power Out function (fig. 3-4). Winch Cable will spool out off of drum.

**CAUTION:** The "OUT" function is for INTERMITTENT USE ONLY, as you are powering drum against the brake, and can damage internal mechanism.

5. If any of the above functions are not working properly, recheck all connections in accordance with Installation Section of this manual, or refer to Troubleshooting Section in back of manual.

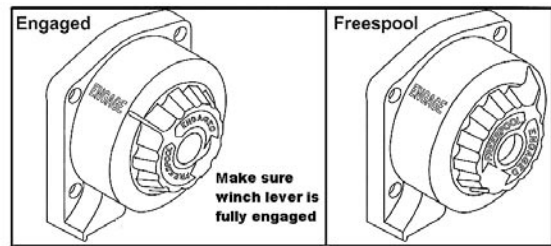

3-1: Clutch Function Diagram

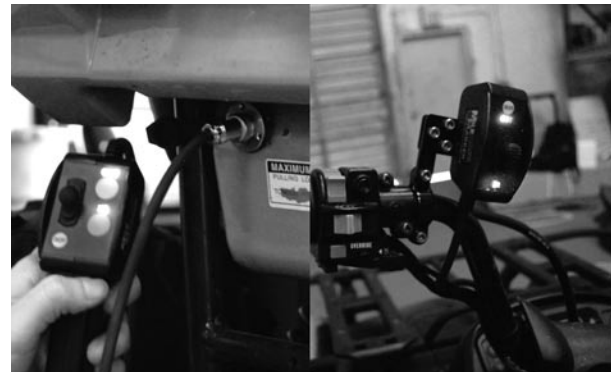

3-2: Power On: Illuminated Blue

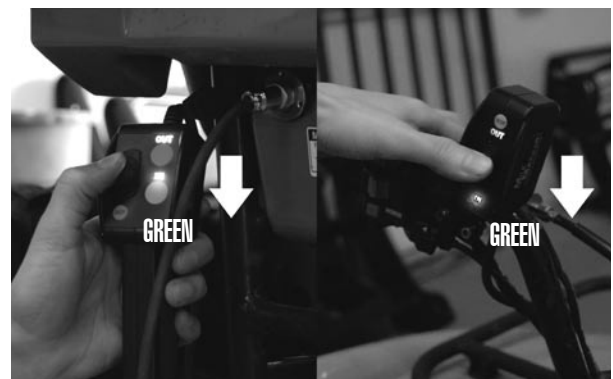

3-3: Power In: Illuminated Green, Toggle Joystick Down, or Press "IN" Button on Wired Pendant

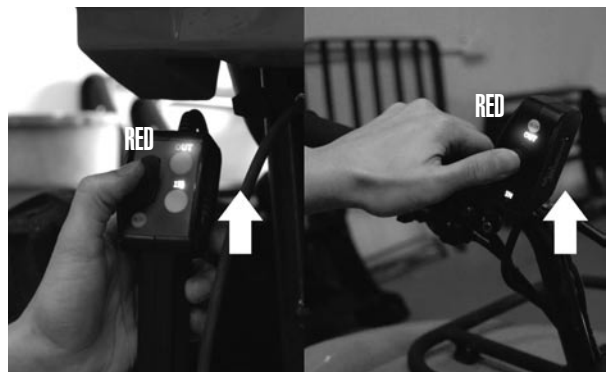

3-4: Power Out: Illuminated Red, Toggle Joystick Up, or Press "OUT" Button on Wired Pendant

# Winch Operation

**NOTE:**For optimal winch performance, it is recommended that you use a fully charged 12V battery with at least 150 Cold Cranking Amperes. Further, it is advised to keep the engine running during the winch operation, so that the battery is being charged continuously.

**CAUTION:** Before you start using your new Mile Marker winch, you will have to re-wind the entire cable on the drum under a load of at least 100 lbs starting with at least 5 wraps on the initial layer. Failure to do so will result in the outer wraps pressing against the inner wraps resulting in the damage of the cable.

Always have at least 5 wraps of cable on the winch drum before winching.

Always ensure that the clutch is fully engaged or fully disengaged to avoid any injuries and damages.

All electrical winches are for intermittent use only. Never run the winch for more than 1 min at maximum rated load. Wait until the motor cools down before resuming winching operation. Usage of a snatch block is recommended to reduce the load on the winch motor.

Always stay clear of the loaded winch cable.

**IMPORTANT:** The VMX Series is a M.O.S.F.E.T. driven, computer controlled winch with Variable Speed line retrieval capabilities. The Variable Speed feature is intended for precision and safety when INITIATING and CONCLUDING pulls ONLY. The winch is not intended to be used under PARTIAL TOGGLE for any extended period of time.

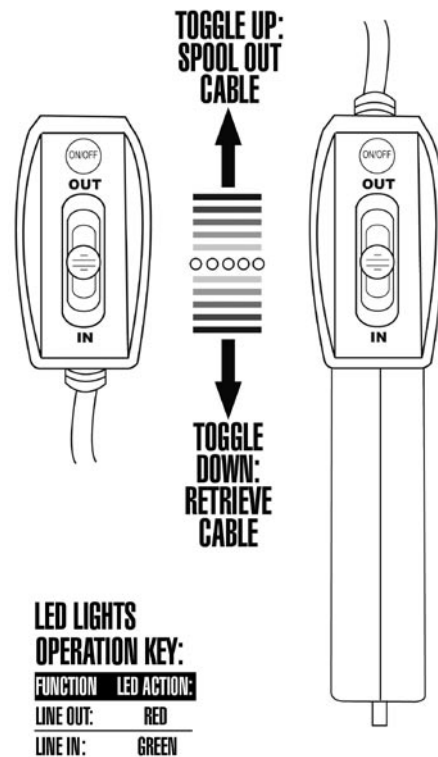

3-5: Function Diagram

## Clutch Operation:

The clutch is operated by rotating the clutch lever clockwise for "Free" and counter clockwise for "Locked or Engaged" (figure 3-1).

Never release the cable while under tension. Doing this can badly damage the winch and/or cause property damage and serious injury.

## Motor Temperature:

ELECTRIC WINCHES ARE DESIGNED FOR INTERMITTENT USE ONLY. Do not run this winch at a high load for an extended period of time. To check the motor temperature: Stop Operation, Secure the load, Release the tension on the cable, and place your hand on the motor to check temperature. If you feel the motor is warm to the touch, let it cool off for a few minutes. If the motor is laboring, stop sooner and more often to check the motor temperature. The Mile Marker VMX Series has a built-in temperature cut-off safety feature (see next section), but close monitoring of motor temperature is a vital component of any winch operation. Using a double line with a snatch block will reduce the load on the winch to about half. The lower the amp load on the winch the longer it will take to heat up the motor.

# Winch Operation

## Spooling Under Load:

Always ensure that wire rope passes between winch drum & mounting surface. Always wind the rope as evenly and tight as possible. Avoid shock loading the winch when spooling in. If this is done you can cause a hazardous condition that can break the wire or damage the winch. Avoid pulling at an angle for an extended period. This will stack the wire up on side of the spool and cause serious damage to the winch. You may have to reposition the wire a few times to allow the winch to pull in a straight line.

## Rigging:

Spool out as much wire as possible to the farthest object available. Keep the wire in as straight a line as you can. Spool the line back on the winch as evenly as possible when retrieving the wire rope. Natural anchors like trees, stumps and rocks are the better choices. Always use a tree saver where ever possible. Only connect the wire rope to an object that will be able to resist the pulling power of the winch being used.

## Safety Features: EXCLUSIVE TO VMX WINCHES

### LOW VOLTAGE/LOW SYSTEM CHARGE WARNING:

1. If the vehicles charging system (measured at the motor control pack) drops below a safe voltage the LED lights will flash. This is to warn you that your charging system is dangerously low and you may not be able to safely use your winch much longer.
2. If the vehicle's charging system (measured at the motor control pack) continues to drop below a safe voltage then LED lights will flash and the winch's on-board computer will shut the winch off. This is to protect your winch and your vehicle.
3. When the vehicles charging system is at a safe voltage, the winch controller will stop flashing and the winch is able to be used again . However, it is recommended that adequate time be given for vehicles charging sytem to fully recover in order to maintain proper voltage for winching.

### OVER TEMPERATURE WARNING:

1. The winch's on-board computer can detect if the winch temperature has gotten too hot. When your winch gets too hot, the LED lights will flash and the on-board computer will shut the winch motor off.
2. When the LED lights stop flashing, your winch is at a safe operating temperature, and you may resume winching as normal.

# Winch Maintenance

- All moving parts within the Electric Winch have been lubricated using high temperature lithium grease at the factory. No further internal lubrication is required for the life of the winch.
- Lubricate the cable periodically using light penetrating oil.
- Electrical connections may corrode over a period of time due to environmental changes. This may result in reduced performance of the winch or even possible electrical shorting. Hence, always clean the electrical connections before and after using the winch.
- After every use of the winch, inspect the cable for damages such as kinks, broken strands etc. When damaged, replace the cable immediately!

**CAUTION:** It is recommended that you replace the cable with superior Mile Marker cables. If replacing from other sources, carefully compare for the maximum load capacity of the cable with that mentioned in the Specifications Section of this manual.

## Troubleshooting

SYMPTOM	POSSIBLE	SUGGESTED
<b>Motor does not turn on</b>	Remote control switch is not turned on.	Turn on Remote control switch.
	LED green, blue, red alternate flashing.	Temperature Over-Heat shutdown, let winch cool down.
	Red green LED flashes.	Low Voltage Warning. Recharge battery.
	Loose battery cable.	Tighten nuts on cable connectors.
	ATV Control Box malfunctioning	If the LEDs do not light up on the Remote Control, and the battery is fully charged, then the control box needs to be replaced.
	Defective motor	Check for voltage at armature port with switch pressed. If voltage is present, replace motor.
	Water has entered motor	Drain and dry. Run in short bursts without load until completely dry.
<b>Motor runs too hot</b>	Long period of operation	Let winch cool down periodically.
<b>Motor runs slowly or without normal power</b>	Battery runs down.	Recharge battery by running vehicle's engine.
	Insufficient current or voltage	Clean, tighten or replace the connector.
<b>Motor runs but cable drum does not turn.</b>	Clutch not engaged	Ensure lever is completely in "engaged" position. If that does not work, contact qualified technician to check and repair.
<b>Motor runs in one direction only</b>	ATV control box is defective or damaged.	Replace control box.



# Parts Breakdown & Assembly: VMX 2.5

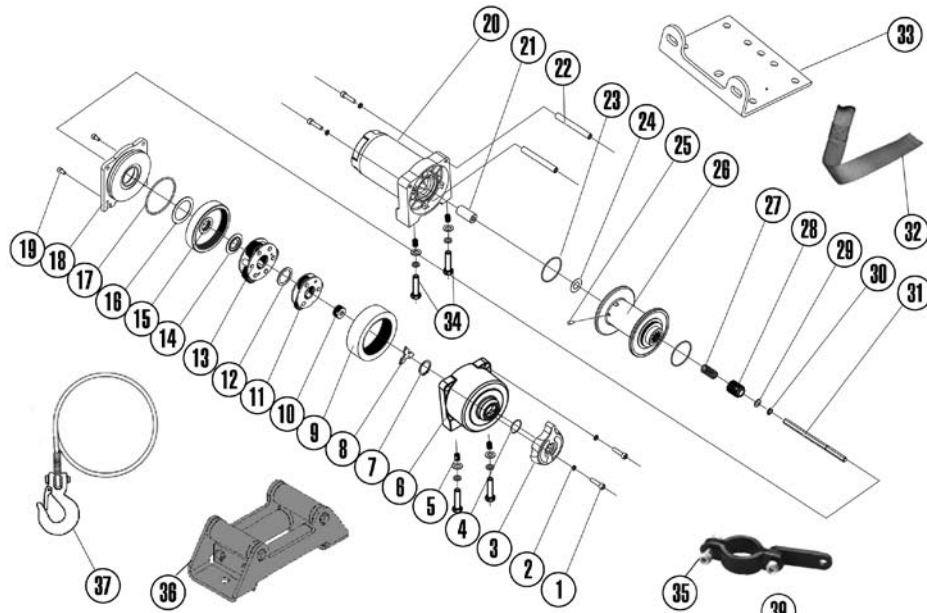

Item	Quantity	Part Number	Description
1	4	77-50105-01	SCREW M6X25
2	4	77-50105-02	SPRING WASHER 6
3	1	77-50105-03	CLUTCH KNOB
4	1	77-50105-04	O-RING 23.6x1.80
5	1	77-50105-05	COIL M8
6	4	77-50105-06	GEAR BOX
7	1	77-50105-07	SPRING RETAINER
8	1	77-50105-08	CLUTCH DRIVEN DISC
9	1	77-50105-09	DUAL GEAR RING
10	1	77-50105-10	GEAR-SUN-INPUT
11	1	77-50105-11	GEAR CARRIER-INPUT
12	1	77-50105-12	WASHER
13	1	77-50105-13	GEAR CARRIER-OUTPUT
14	1	77-50105-14	NYLON RETAINING RING
15	1	77-50151-15	GEAR DISC-OUTPUT
16	1	77-50105-16	WASHER
17	1	77-50105-17	O-RING 95x2.65
18	1	77-50105-18	COVER-GEARBOX
19	1	77-50115-19	SCREW M5x10
20	1	77-50105-20	MOTOR END
21	1	77-50105-21	CONNECTOR
22	2	77-50105-22	TIE BAR
23	2	77-50105-23	O-RING 46.2X1.8
24	1	77-50105-24	SPACER
25	1	77-50105-25	SCREW M6X10
26	1	77-50105-26	DRUM
27	1	77-50105-27	SPRING-CLUTCH
28	1	77-50105-28	CLUTCH GEAR
29	1	77-50105-29	WASHER
30	1	77-50105-30	RETAINING RING
31	1	77-50105-31	DRIVEN AXLE
32	1	30-5040	HAND-SAVING STRAP
33	1	77-50105-33	MOUNT PLATE
34	4	77-50105-34	HARDWARE: BOLTS, WASHER, SPRING WASHER
35	1	NA: SEE ITEM 46	HANDLE BAR CLAMP
36	1	WH2	ROLLER FAIRLEAD
37	1	77-50105-37	CABLE WITH HOOK

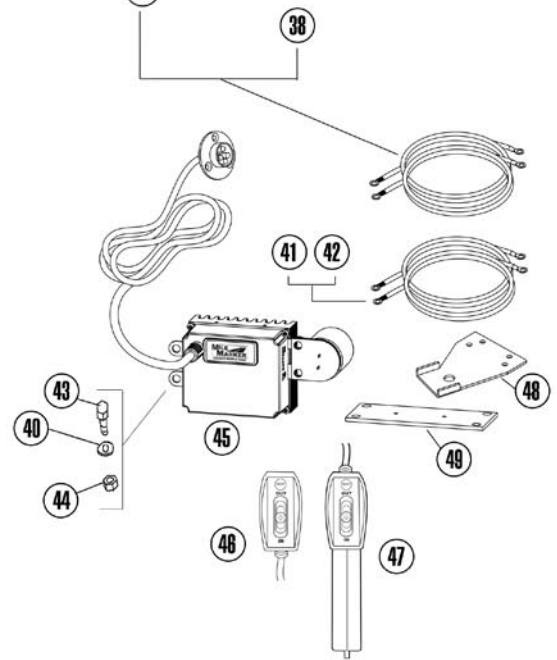

Item	Quantity	Part Number	Description
38	1	77-50105-38	CABLE ASSY, 6 GA, BLACK, 96"
39	1	77-50105-39	CABLE ASSY, 6 GA, RED, 96"
40	4	77-50105-40	1/4" WASHER
41	1	77-50105-41	CABLE ASSY, 6 GA, BLACK, 36"
42	1	77-50105-42	CABLE ASSY, 6 GA, RED, 36"
43	4	77-50105-43	1/4" - 20 x 1/2" HEX CAPSCREW
44	4	77-50105-44	1/4" - 20 HEX NUT
45	1	93-72105-06	CONTROL BOX- MIFI TECHNOLOGY
46	1	93-72106	MIFI TECH. HANDLEBAR PENDANT
47	1	93-72050	MIFI TECH. JOYSTICK PENDANT 12'
48	1	92-72105-01	MULTI MOUNT BRACKET
49	1	92-72105-02	FLAT BRACKET

# Parts Breakdown & Assembly: PE 2.5

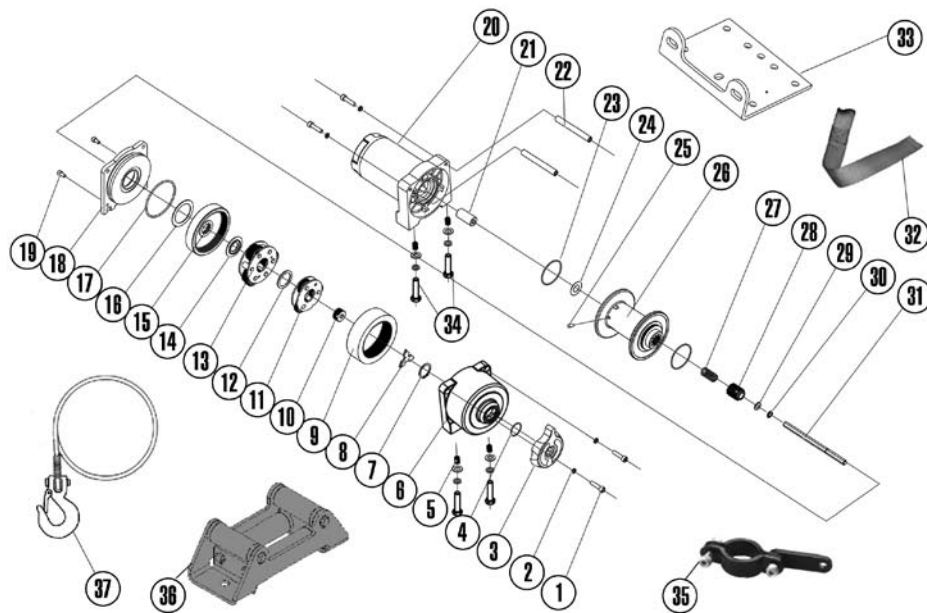

Item	Quantity	Part Number	Description
1	4	77-50105-01	SCREW M6X25
2	4	77-50105-02	SPRING WASHER 6
3	1	77-50105-03	CLUTCH KNOB
4	1	77-50105-04	O-RING 23.6X1.80
5	1	77-50105-05	COIL M8
6	4	77-50105-06	GEAR BOX
7	1	77-50105-07	SPRING RETAINER
8	1	77-50105-08	CLUTCH DRIVEN DISC
9	1	77-50105-09	DUAL GEAR RING
10	1	77-50105-10	GEAR-SUN-INPUT
11	1	77-50105-11	GEAR CARRIER-INPUT
12	1	77-50105-12	WASHER
13	1	77-50105-13	GEAR CARRIER-OUTPUT
14	1	77-50105-14	NYLON RETAINING RING
15	1	77-50151-15	GEAR DISC-OUTPUT
16	1	77-50105-16	WASHER
17	1	77-50105-17	O-RING 95X2.65
18	1	77-50105-18	COVER-GEARBOX
19	1	77-50115-19	SCREW M5X10
20	1	77-50105-20	MOTOR END
21	1	77-50105-21	CONNECTOR
22	2	77-50105-22	TIE BAR
23	2	77-50105-23	O-RING 46.2X1.8
24	1	77-50105-24	SPACER
25	1	77-50105-25	SCREW M6X10
26	1	77-50105-26	DRUM
27	1	77-50105-27	SPRING-CLUTCH
28	1	77-50105-28	CLUTCH GEAR
29	1	77-50105-29	WASHER
30	1	77-50105-30	RETAINING RING
31	1	77-50105-31	DRIVEN AXLE
32	1	30-50040	HAND-SAVING STRAP
33	1	77-50105-33	MOUNT PLATE
34	4	7-50105-34	HARDWARE: BOLTS, WASHER, SPRING WASHER
35	1	NA: SEE ITEM 38	HANDLE BAR CLAMP
36	1	WH2	ROLLER FAIRLEAD
37	1	77-50105-37	CABLE WITH HOOK

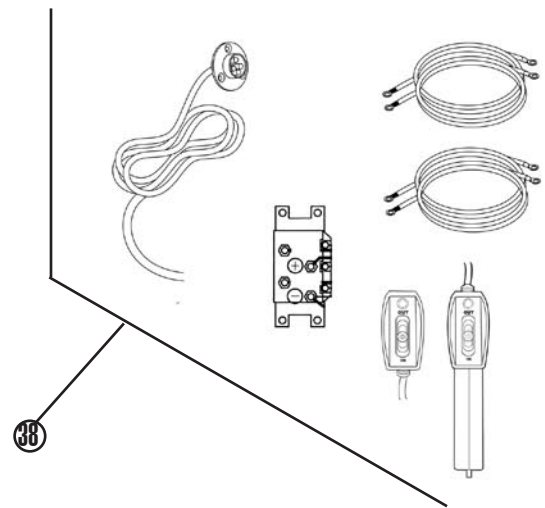

Item	Quantity	Part Number	Description
38	1	76-50110-25C	SOLENOID/CONTROL ASSEMBLY



# Warranty Information

## Limited 2-Year Electric Winch Warranty

Mile Marker, Inc. offers a limited two (2) year warranty to the original retail purchaser for each new Mile Marker electric winch, used as a recreational recovery winch only, against manufacturing defects in workmanship and materials on all mechanical components. Electrical components consisting of motors, solenoids, wiring, wire connectors and associated parts have a limited one (1) year warranty. New cable assemblies are warranted against defects in workmanship and materials when received by the retail purchaser. There is no applicable warranty after initial use. Excluded from this warranty are the finish of the winch and any condition Mile Marker determines to have been caused by misuse or abnormal use. Warranty registration cards for each winch must be submitted at the time of purchase or within 30 days by the end user. Registration cards must reference winch serial number to be valid. Warranty will only be valid for the original purchaser of the winch and installed on the vehicle for which it was originally registered. The owner will be responsible for removing the winch and returning it to Mile Marker freight prepaid unless a determination is made that replacement parts can be sent out which will remedy the problem. Mile Marker will repair or replace any or all winch parts, which after inspection determines to be defective. If the product was purchased in the United States, the owner must contact our warranty department to get a Return Goods Authorization (RGA) Number before returning the product. If the product was purchased outside the United States, the owner must return the product to the original place of purchase.

Mile Marker electric winches are intended for recreational self recovery usage. The warranty is void if the winch is used in commercial or industrial applications.

### General Warranty Procedure and Policy:

For U.S. Customers: DO NOT RETURN TO PLACE OF PURCHASE. The end user MUST contact Mile Marker directly by calling 1-800-886-8647. Our customer service representatives will work to resolve any warranty issues. The owner must receive a Return Goods Authorization (RGA) Number before returning any product. The owner will be responsible for removing the product and returning it to Mile Marker freight prepaid unless a determination is made that replacement parts can be sent out which will remedy the problem. Mile Marker will repair or replace any or all parts, which after inspection determines to be defective.

For International Customers: RETURN PRODUCT TO PLACE OF PURCHASE, OR IF NOT FEASIBLE, CONTACT MILE MARKER. The Distributor or Dealer may then repair or replace the product. The dealer may then contact Mile Marker by calling 1-800-886-8647 to receive an RGA number to return merchandise for warranty consideration. If a Distributor or Dealer chooses to submit warranty claims for the end user or Jobber there are certain guidelines that need to be adhered to. They are as follows:

- The merchandise must be within the warranty period. See the Mile Marker warranty statement for time periods.
- Freight must be prepaid to the designated warranty service location.
- Mile Marker will inspect the returned merchandise and make a determination if the problem is warrantable. If it is warrantable Mile Marker will repair and return freight prepaid.

For all returned merchandise: If it is determined that a problem is not warrantable Mile Marker will contact the returning party to determine a disposition of the merchandise as follows:

- Return "as is" without repairing.
- Provide an estimate of the repair costs to the sender for approval/disapproval and take action as directed by the sender.

After receiving the Returns Good Authorization (RGA) Number: Attach the RGA Number, your name, address, phone number and a detailed description of problem relating to malfunction and a copy of a bill of sale. To obtain any warranty coverage, it is absolutely necessary that you present proof of purchase acceptable to Mile Marker, such as a purchase receipt. Please remove the cable from any winch to save both parties on freight costs, and package the product either in its original packaging, or other adequate means of packaging. Mile Marker will not repair or warranty items that are damaged in shipment to us, unless it is no fault of the customer.



#### Warranty Exclusions:

There are certain conditions that are not eligible for warranty consideration by Mile Marker. They are as follows but not limited to the following:

- Winches returned in pieces will not be considered for warranty.
  - Any item that has been involved in an accident will not qualify for warranty.
  - Winches caked in mud will not qualify for warranty.
  - Winches that have been modified or taken apart and reassembled will not qualify for warranty.
  - Winches that have the tie bars separated from the housing will not qualify for warranty.
  - Winches that show general abuse will not qualify for warranty.
  - Products damaged in shipping due to poor packaging will not qualify for warranty.
- Mile Marker will not issue an RGA for products that have been batched. If a Distributor or dealer receives a winch or other item for warranty consideration by Mile Marker, it must have an RGA issued and sent to the designated service location within 15 days of receipt from the end user. Mile Marker will not accept any merchandise without an RGA number or that exceeds the 15 day period. No credits will be provided. Products returned to Mile Marker will be repaired or replaced and returned.

Important Notice: To the fullest extent permitted by applicable law, the following are hereby excluded and disclaimed:

1. All warranties of fitness for a particular purpose;
2. All warranties of merchantability;
3. All claims for the face hereof.

Some states do not allow the above exclusions or disclaimers in consumer transactions and as such this disclaimer/exclusion may not apply to you. To the extent such warranties of fitness or merchantability are deemed to apply to this product, they exist for only so long as the express limited warranty elsewhere set forth is in existence.

The obligation under this warranty, statutory or otherwise, is limited to the replacement or repair at the manufacturer, upon inspection of such part(s), to have been defective in material or workmanship. This warranty does not obligate Mile Marker, Inc. to bear the cost of labor or transportation charges in connection with the replacement or repair of defective parts, nor shall it apply to a product upon which repairs or alterations have been made, unless authorized by the manufacturer, or for equipment misused, neglected or improperly installed.

Mile Marker, Inc. reserves the right to change, alter or improve its products in design, materials or appearance without incurring any obligation to incorporate such changes in products that were previously manufactured.

Consequential Damages: Mile Marker accepts no liability, responsibility or obligations for incidental, indirect or consequential damages from the use of Mile Marker products no matter what the conditions of use. This includes injuries, repair costs, lost time, economic impacts and other similar impacts. Some states do not allow the above exclusions or disclaimers in consumer transactions and as such this disclaimer/exclusion may not apply to you.

This warranty gives you specific legal rights and you may have other legal rights which vary from state to state. To submit a warranty claim contact; Mile Marker, Inc. Warranty Administrator 2121 Blount Road, Pompano Beach , FL 33069 (800) 886-8647

Design, materials, and specifications are subject to change without notice. Mile Marker Inc. has made every effort to ensure the accuracy of the information contained in this manual, but does not accept liability for errors or omissions.



International  
Organization for  
Standardization

# MILE MARKER<sup>INCORPORATED</sup>

2121 BLOUNT ROAD  
POMPANO BEACH, FL 33069 USA

800.886.8647 TOLL FREE

954.782.0604 USA & INT'L

954.782.0770 FAX

[WWW.MILEMARKER.COM](http://WWW.MILEMARKER.COM)  
[INFO@MILEMARKER.COM](mailto:INFO@MILEMARKER.COM)

