

ASSEMBLY INSTRUCTIONS FOR MODEL #20045 UNIVERSAL PET BARRIER

PARTS LIST		
ITEM	DESCRIPTION	QUANTITY
A	BARRIER BAR ASSEMBLY	2
B	VERTICAL SUPPORT TUBE	2
C	MOLDED FOOT	4
D	INSERT – MOLDED FOOT	4
E	THREADED ROD (WITH WING NUT)	2
F	SCREW	2

1. Remove the “Molded Foot Insert” (D) from each “Molded Foot” (C) and set aside.

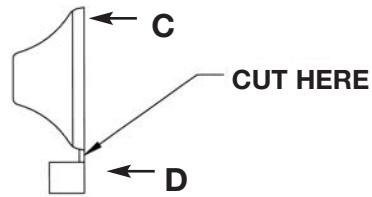

2. Place both “Barrier Bar Assemblies” (A) onto a flat surface with the “Hollow Plastic Links” facing upward. Force the small end of the “Vertical Support Tubes” (B) through the “Hollow Plastic Links” of each “Barrier Bar Assembly” (A). Press a “Molded Foot” (C) onto the small end of each “Vertical Support Tube” (B).

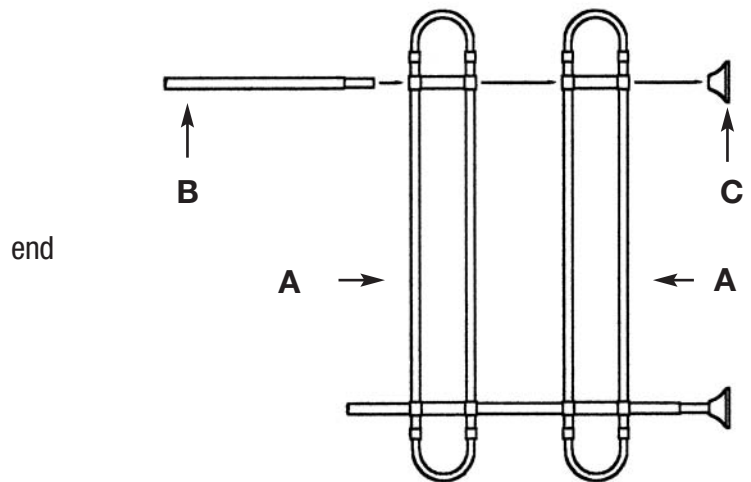

3. Using the “Molded Foot Inserts” (D) (set aside in step 1) force an “Insert” (D) onto each of the “Threaded Rods” (E). With the assembled “Threaded Rod” (E) positioned as shown at right, press a “Molded Foot” (C) onto the “Molded Foot Insert” (D).

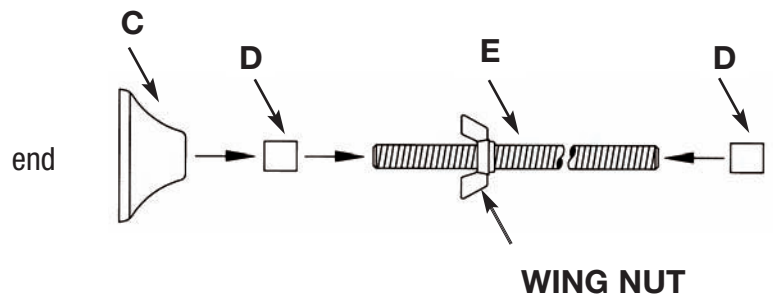

4. Place the “Threaded Rod Assemblies” (E) into the open ends of the “Vertical Support Tubes” (B).

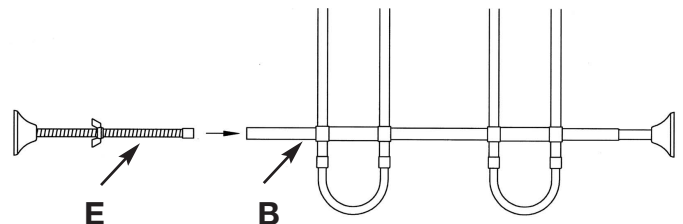

5. Place the assembled unit into your vehicle with the "Threaded Rod" components on the floor. Extend the upper assembly upward until it fits snugly against the roof and the "Threaded Rods" rest on the floor. Rotate "Wing Nuts" on "Threaded Rods" until entire unit is securely held in place.

Once the "Pet Barrier" is installed securely, move the "Barrier Bar" assemblies up/down and in/out to optimize the barrier surfaces.

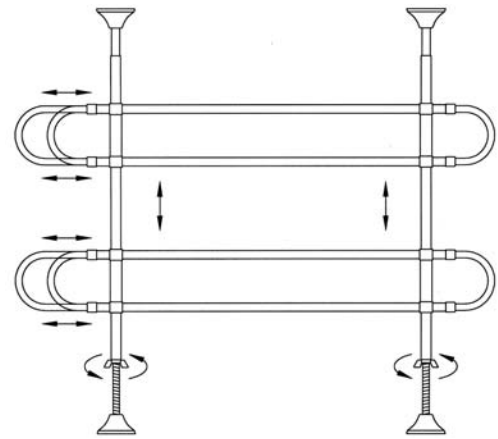

6. After achieving the optimum barrier surface, lock the "Barrier Bar" assemblies in place by driving a screw *(F) into each "Hollow Plastic Link" and tightening the screw.

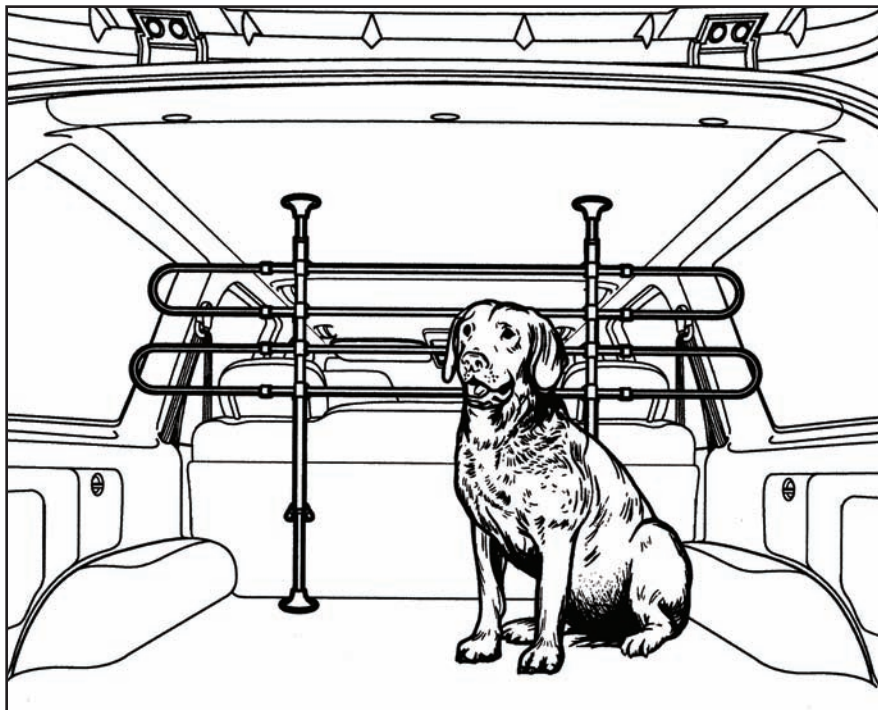
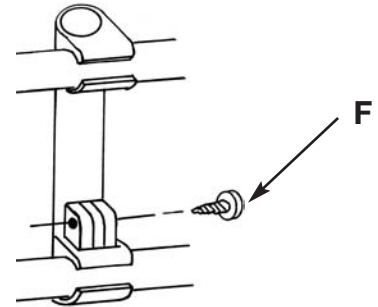

For installation assistance or to order parts, call the
Cequent Help Hotline: 1-800-234-6992
Monday through Friday 9:00 am to 5:00 pm.

Cequent Consumer Products, Inc.
29000-2 Aurora Road • Solon, Ohio 44139
www.cequent-cpi.com