



A M E R I C A N   E X P E D I T I O N  
V E H I C L E S

---

# **JK V8 HEMI® BUILDER KIT**

## **Overview**

### **Installation Guide**

5.7L & 6.1L HEMI  
2007 - 2008 JK - SWB, LWB



Congratulations on purchasing your AEV HEMI JK Installation kit. These instructions have been written for shops or DIY individuals with experience in general mechanics and welding. AEV also assumes that this kit will be installed in a shop environment with access to general shop equipment. If you are not familiar with JK systems, please reference the Jeep Service Manual available at any Chrysler dealer.

### **TIP 1:**

Although it is not required, AEV recommends using a two post hoist to remove the body from the vehicle. The Jeep JK Wrangler was designed by Chrysler to have the body and chassis built as two complete assemblies which are then mated together on the assembly line, because of this; removal of the body only requires about 45 minutes. The general procedure is outlined below:

1. Discharge the AC system
2. Disconnect the steering linkage
3. Disconnect the appropriate brake lines at the ABS Module
4. Disconnect the battery harness from the battery.
5. Disconnect the engine ground located to the left of the battery.
6. Unplug the 34 way powertrain connector at the fire wall (C100) and the 34 way Chassis connector (C300) on the right hand side of the radiator.
7. Unplug the PCM (C1, C2, C3, and C4).
8. Disconnect the front left O2 sensor located below the master cylinder.
9. Drain and disconnect the radiator and heater hoses.
10. Disconnect the transmission cooler lines at the radiator.
11. Remove the power steering reservoir from the body.
12. Remove all the body mounts.
13. Disconnect the emergency brake cables at the rear axle.
14. Disconnect the transmission and transfer case cables
15. Disconnect the fuel fill hose.
16. Disconnect all vapor lines at the purge valve.
17. Disconnect the top of the rear axle vent line.

Once the body is separated, it is easy to remove the stock powertrain, weld in the new mounts and to install the assembled 5.7 or 6.1L powertrain and exhaust into the chassis. While the body is on the hoist, the completed cooling module, battery tray, air filter, and steering modifications can be completed. The body is then mated back to the chassis using the reverse procedure, the harnesses are plugged in, the brake lines are hooked back up and bled, the radiator hoses can then be connected and the vehicle can be filled with fluid and started.



## **TIP 2:**

There are several variations of sensors, alternators, power steering pumps and air conditioning compressors used in different applications from 2005 onward. Please check that you have all the correct parts listed in the Bill of Materials provided. Pay particular attention to the AC pump, power steering pump and cam sensor.

## **TIP 3:**

The exhaust system is designed to fit the 5.7L motor in a stock application. 6.1L motors can use the 5.7 exhaust but will be required to use the 5.7L Manifolds, Gaskets, and bolts also listed in the Bill of Materials. The routing has been fitted assuming a stock suspension and bumpers. The use of aftermarket suspensions, bumpers or other components may require modifications to the exhaust system or other components. Two Door Wranglers will need a section of straight exhaust pipe cut out of the system.

## **TIP 4:**

Jeep Wranglers being converted from Manual to Automatic Transmissions will require AEV Part #31001027AA which is an additional wire for the body side of the harness. The other parts required to perform the manual to automatic conversion are listed in the Bill of Materials.

## **TIP 5:**

Four door wranglers can use the stock driveshaft's front and rear; two door models will need a new or modified rear driveshaft.

## **TIP 6:**

WK and XK powertrains come with a rear sump aluminum oil pan. This pan will work but is easily damaged off-road. As an option, a steel pan is available from the Dodge Ram and all parts are listed in the supplied Bill of Materials. LX powertrains come with a front sump aluminum pan and will need to be changed to the steel pan. Be sure to reference a 5.7 manual regarding the "Torque To Yield" main bearing cap bolt.

## **TIP 7:**

The stock JK transfer case cable bracket must have the corner clipped off in order to clear the floorpan as shown in the photo.

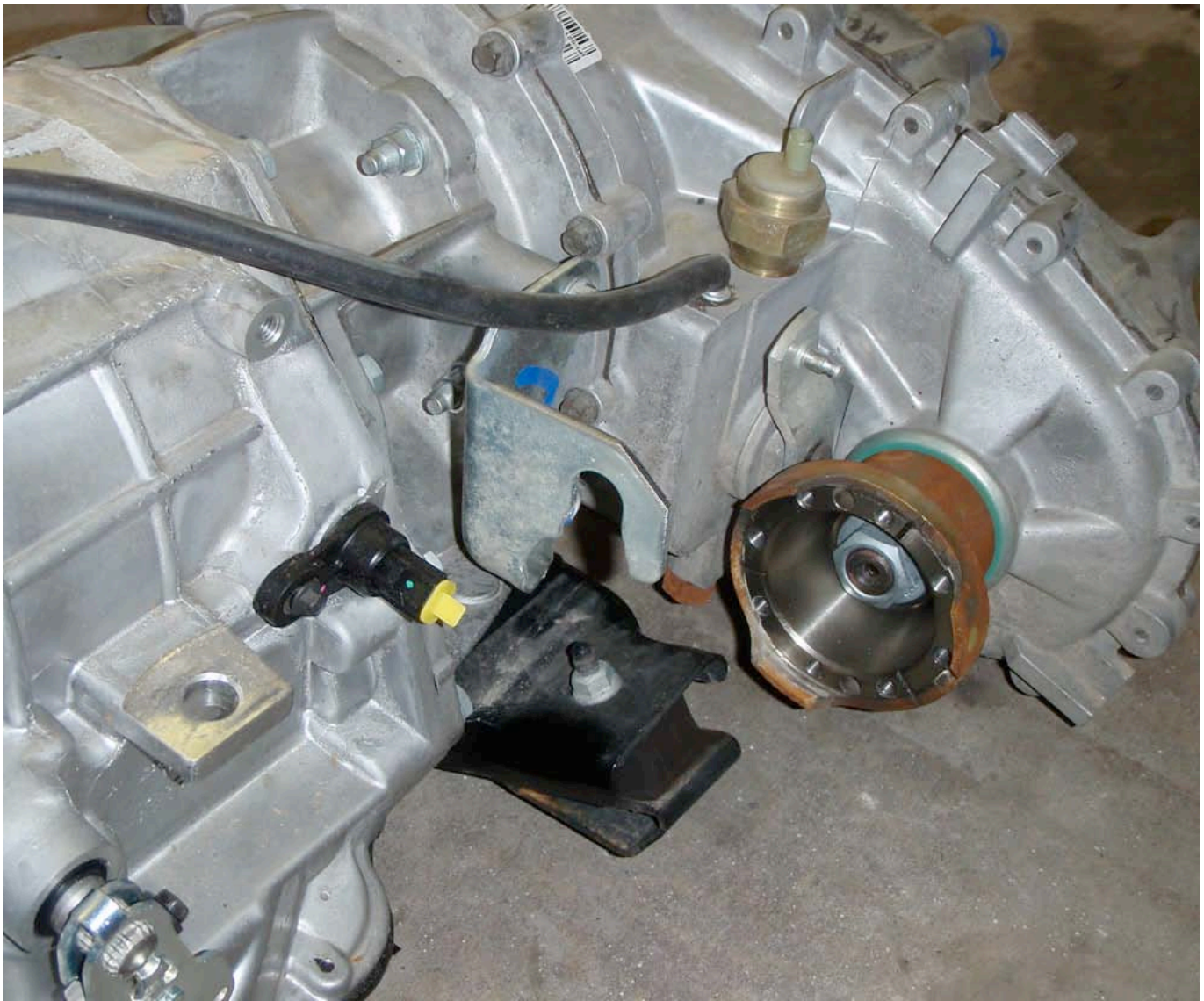

FIG. 1

The AEV Harness is the same for 5.7L and 6.1L conversions. There are two connectors included that are for the 5.7L engines only and must be tied up on 6.1L conversions. The MDS connector located at the top rear of block must be zip tied to the harness and will not be used for 6.1L. The EGR solenoid connector (black 6-way) located at the front right of engine has a plastic clip located in the connector which is designed to fasten under the air filter bracket on 6.1L conversions.



**TIP 8:**

5.7 conversions can utilize the Grand Cherokee or Commander engine cover however it must be modified prior to installation using the template provided on the last page of this document (FIG. 2).



A M E R I C A N   E X P E D I T I O N  
V E H I C L E S

---

## COMMENTS OR QUESTIONS?

### **American Expedition Vehicles**

Phone: 406.251.2100

Email: [tech@aev-conversions.com](mailto:tech@aev-conversions.com)

Website: <http://www.aev-conversions.com>

FIG 2

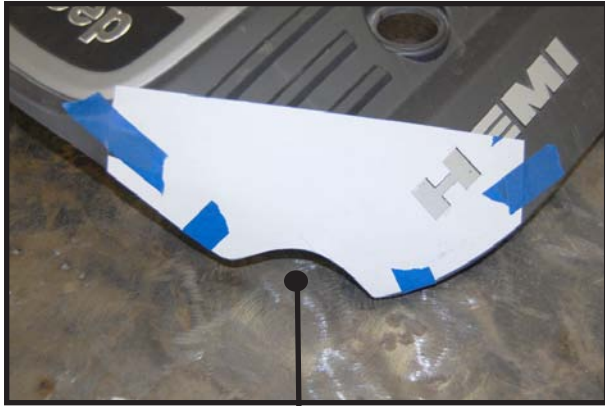

Remove this section of plastic

hemi cover edge

\* Retain this side of the paper to align with shape of hemi cover edge / hemi badging "H".

cut along these lines

hemi badging "H"

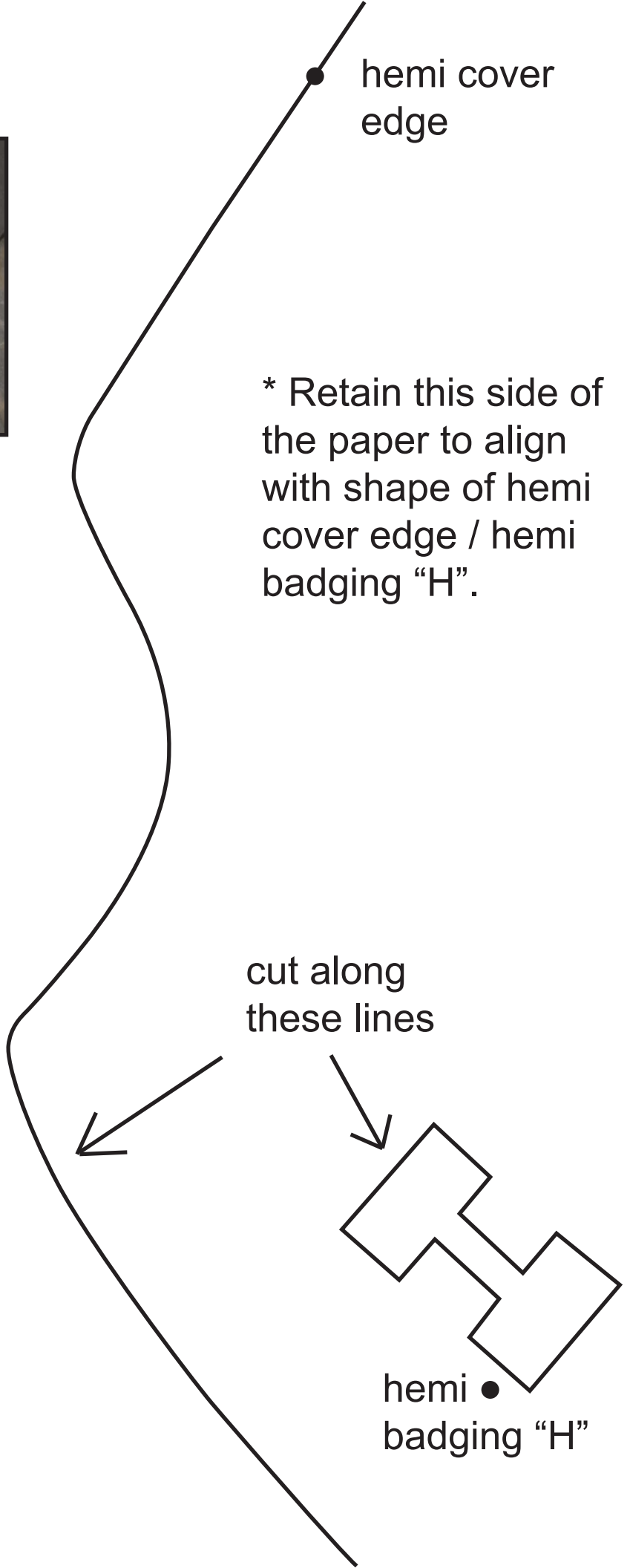
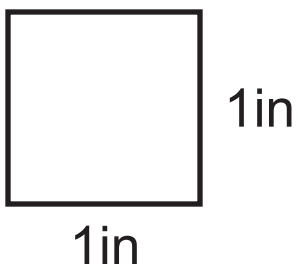



A M E R I C A N   E X P E D I T I O N  
V E H I C L E S

---

# JK V8 HEMI® BUILDER KIT Engine & Transmission Mounting

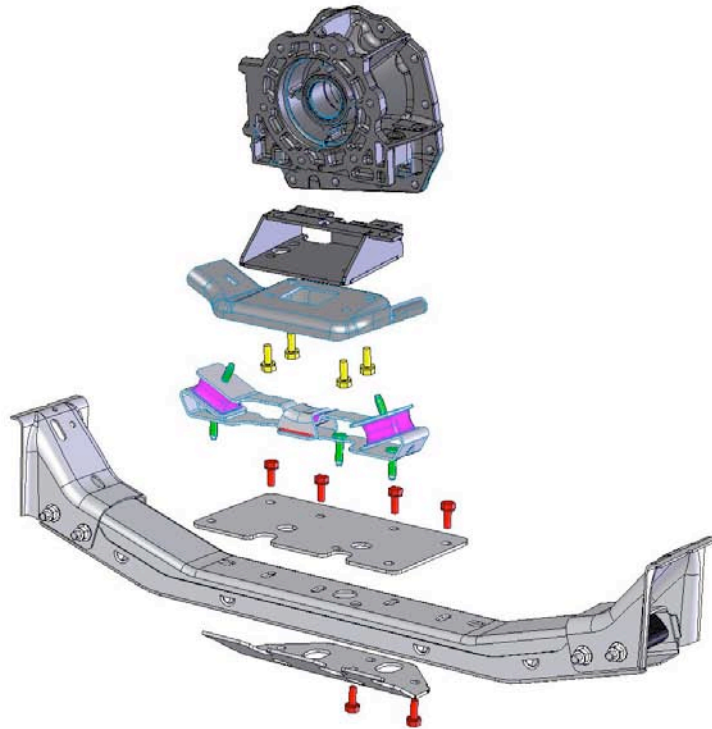

## Installation Guide

5.7, 6.1 WK or XK Powertrains with Dodge 4WD Adapter in place  
07+ JK – SWB, LWB, LHD only





## INSTRUCTIONS

### A. MOUNTING PREPARATION

1. After the 3.8L Powertrain is removed, disconnect the front ABS connectors at the frame and remove the right side wiring harness bolt on clips that are located on the frame behind the right side shock tower.
2. Cut off the OE engine mounts from the frame and clean up the area with an 80 grit sanding disc.

### B. INSTALLATION OF THE ENGINE MOUNTS

1. Each engine mount has an L or R inscribed into the metal indicating the Left from the Right. There is also an arrow indicating the front of the mount.
2. If the mounts are coated, remove the coating in all areas to be welded.
3. Place the mounts on the frame rail and line up the oval holes precisely. Tack in place and finish weld as shown.
4. Paint all bare areas as required
5. Reinstall the wiring harness mount with the stock hardware.





AMERICAN EXPEDITION  
VEHICLES

---

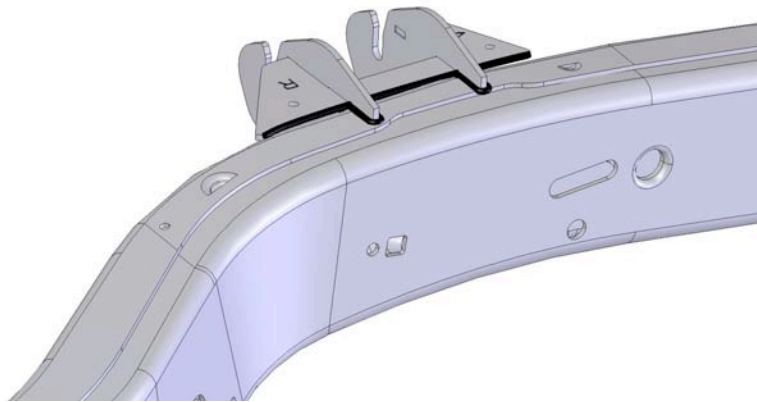
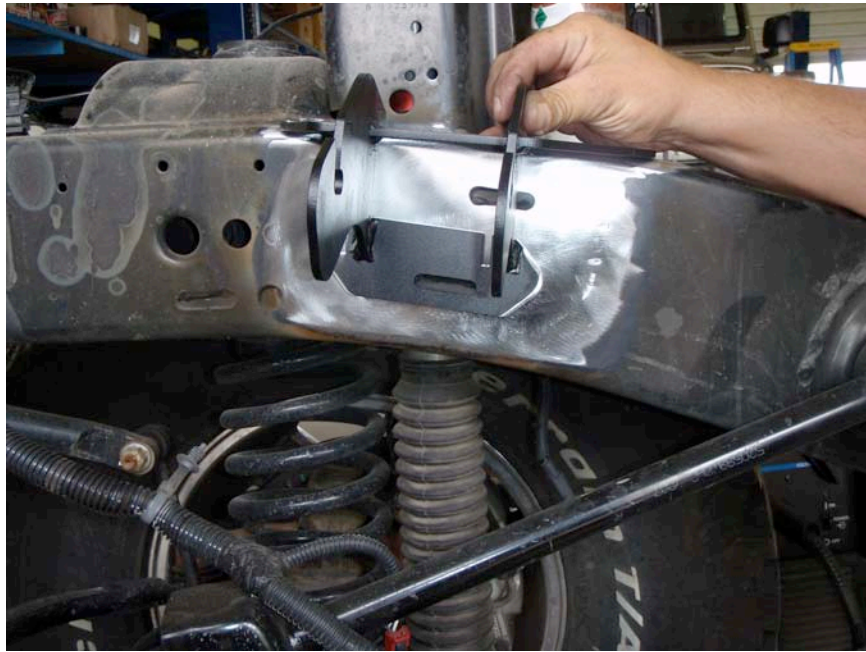



AMERICAN EXPEDITION  
VEHICLES

---

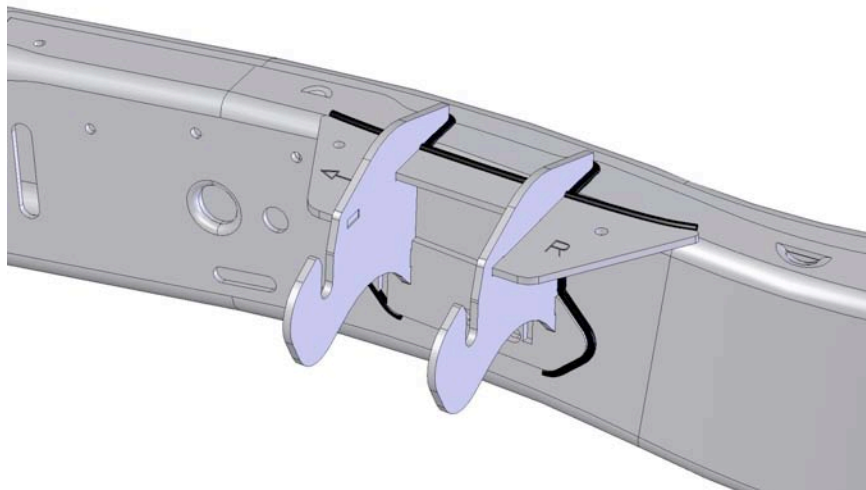
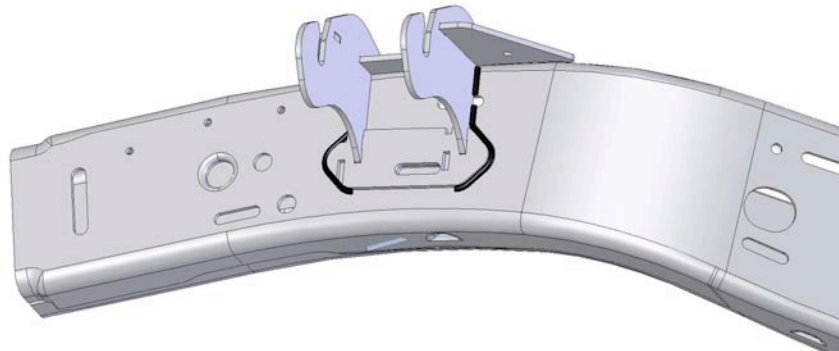
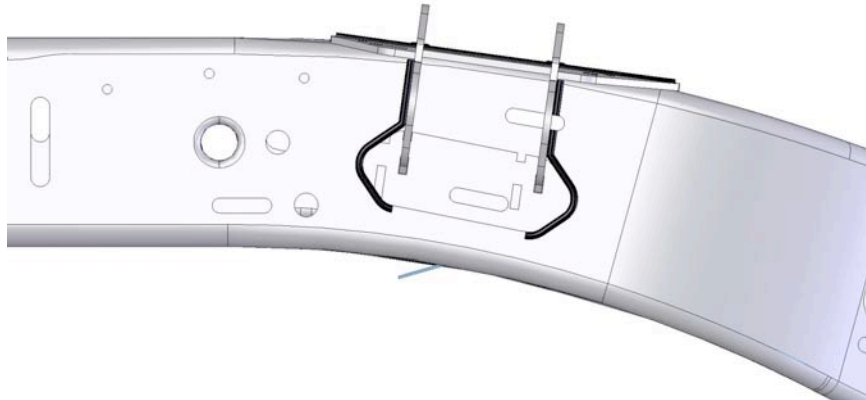

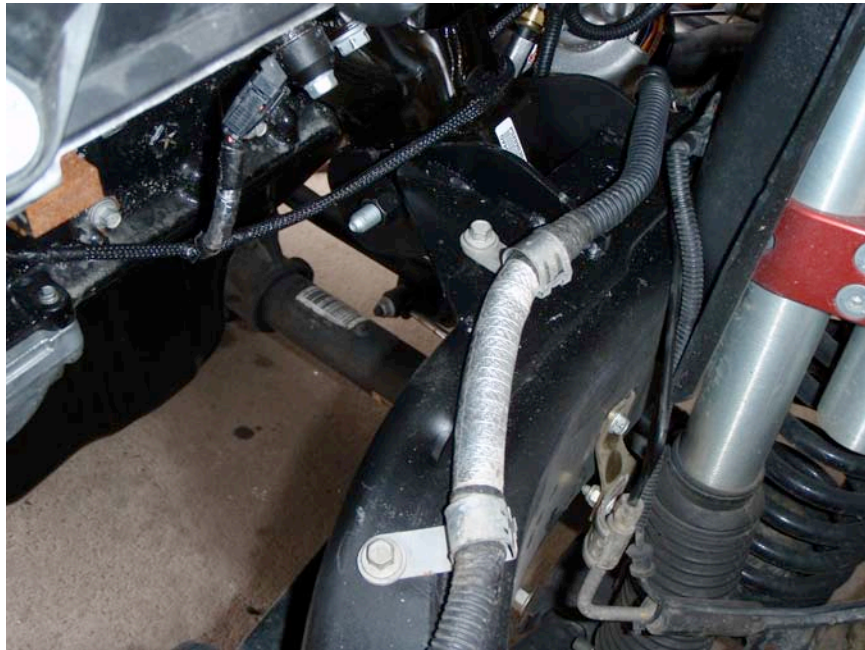

### **C. INSTALLATION OF THE TRANSMISSION MOUNT**

1. All 5-45 Transmissions must have the ¾ Ton or 1 Ton Dodge 4WD adapter (Mopar 52119433AB) along with the seal (Mopar 52119498AA) installed prior to the transmission mount.
2. Install the AEV Mount to the 4WD Adapter on the transmission using the stock bolts.
3. Install the stock JK transmission Isolator to the AEV Transmission Mount using the two 3/8x1" bolts, nuts and washers and two 1/2"x1" bolts, nuts and washers.

### **D. INSTALLATION OF THE CROSS-MEMBER MOUNT**

1. Begin by bolting the top plate of the transmission cross member mount to the JK transmission isolator using the stock hardware.
2. Bolt the top plate of the transmission cross member mount to the JK cross member using 4 of the 1/2-13 bolts, washers and flange nuts.
3. Bolt the bottom plate of the transmission cross member mount to the bottom of the JK cross member using three of the stock bolts into the cross member nutserts. Drill out one hole using the bottom plate as a drill template. Use the remaining two 1/2-13 bolts, washers and flange nuts to secure the bottom plate to the cross member.
4. Remove any paint from the top and bottom plates and weld as shown.
5. Paint any raw material and welds.



AMERICAN EXPEDITION  
VEHICLES

---

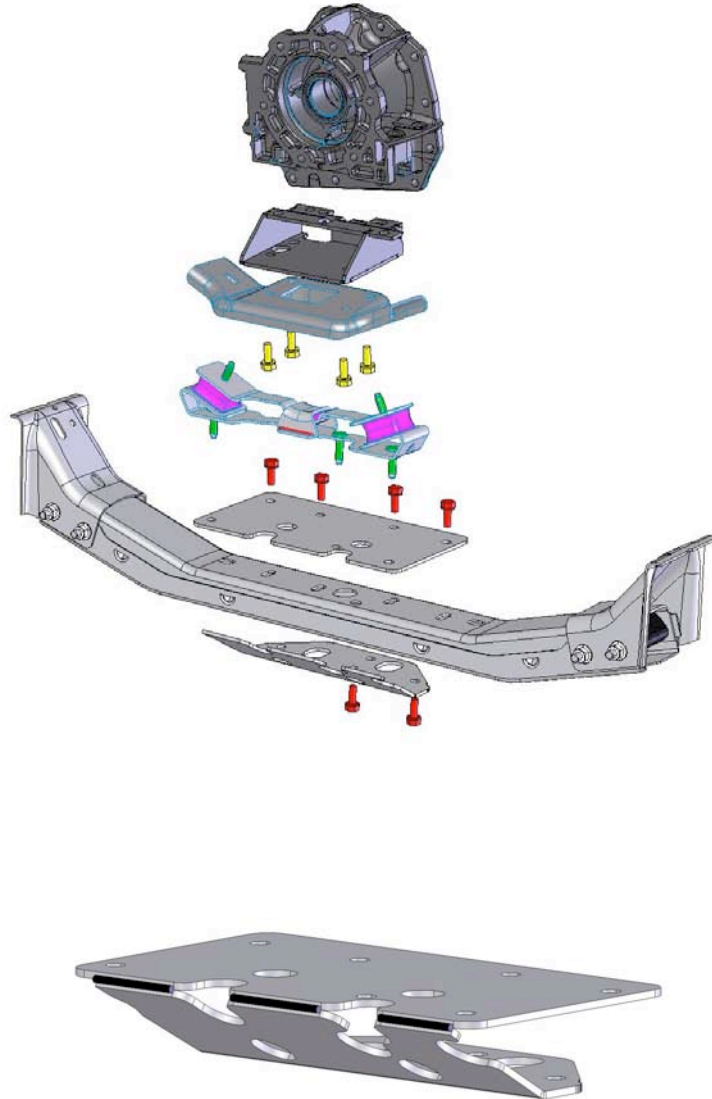



AMERICAN EXPEDITION  
VEHICLES

---

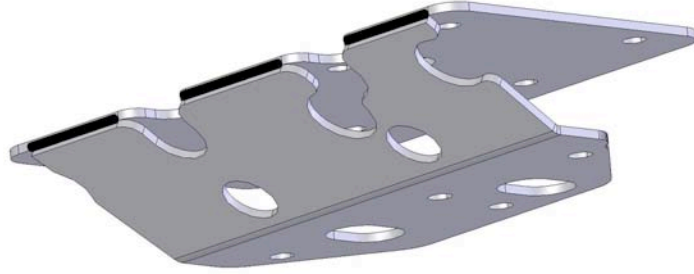



A M E R I C A N   E X P E D I T I O N  
V E H I C L E S

---

## COMMENTS OR QUESTIONS?

### **American Expedition Vehicles**

Phone: 406.251.2100

Email: [tech@aev-conversions.com](mailto:tech@aev-conversions.com)

Website: <http://www.aev-conversions.com>





## JK OPTIMA GROUP 31 Battery Tray

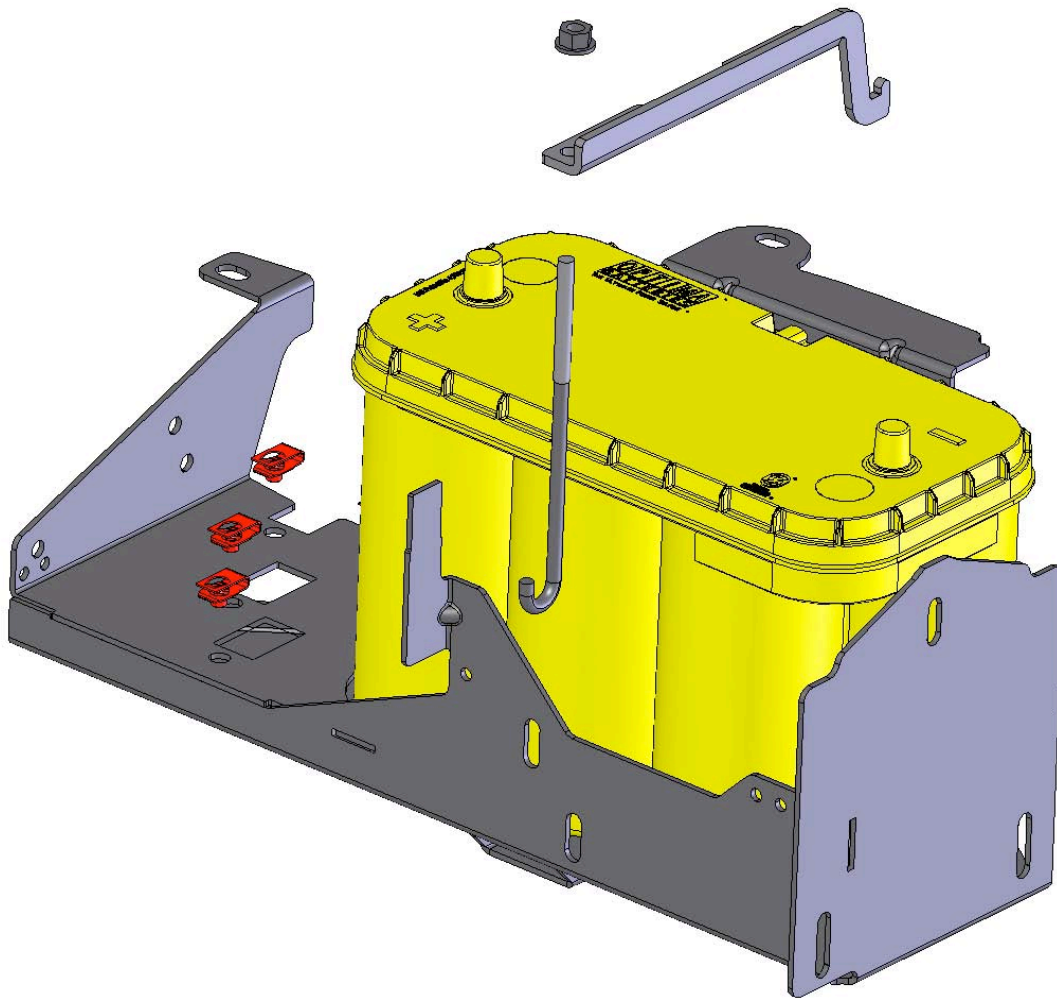

### Installation Guide

3.8, 5.7, 6.1 Powertrains  
07+ JK - SWB, LWB, LHD only  
Stock battery or Optima Group 31





## PREPARATION

### A. REMOVE THE FACTORY BATTERY TRAY

1. Remove the factory Air box, Purge Valve, and Battery.
2. Release the TIPM (fuse block) from the battery tray; disconnect the large 34 way (black) connector as shown.
3. Remove the tray from the vehicle.

### B. INSTALL THE NEW TRAY

1. The new tray is a tight fit and there is only one way to install it without bending the mounting tabs. Place the new tray starting with the three bolts on the rear of the tray; try to slide the tray into place in the front of the vehicle using a motion that is horizontal, from the center of the vehicle outward. Use the factory bolts to fasten the tray into position.
2. Remove the TIPM bracket and the speed nuts from the original tray, re-use this hardware on the AEV Tray and re-mount the TIPM and 34 way connector.
3. Trim the studs on the firewall using a cut-off wheel.
4. Install the battery as shown using the included bracket, J-bolt and nut.
5. Mount the purge valve and rearrange the hoses as shown.

### C. 3.8L AIR BOX MOUNTING

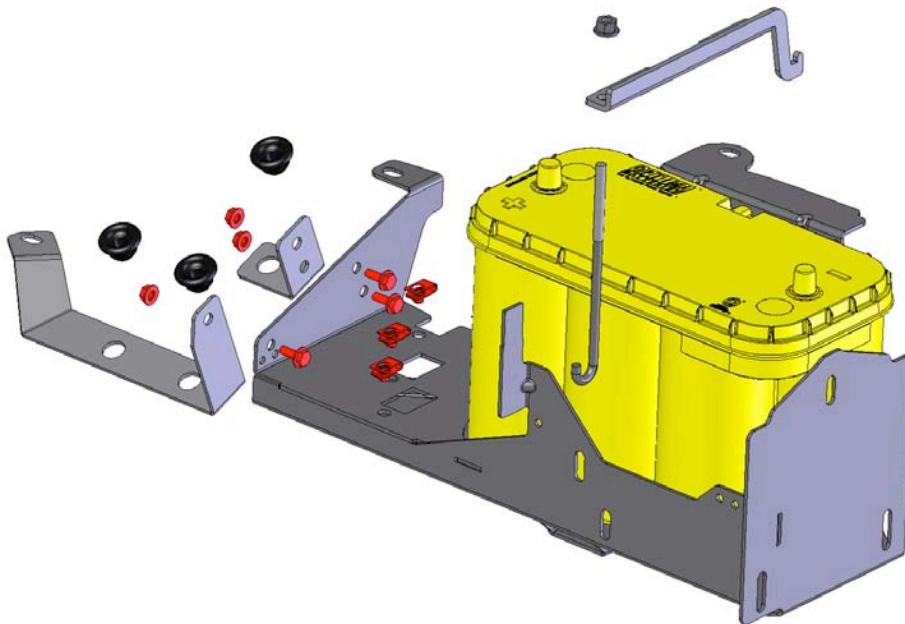



1. Mount the included brackets as shown to the front of the AEV Battery Tray. Install the bolts from inside the battery tray outward.
2. Remove the stock rubber air box isolators from the original tray and reuse them in the supplied brackets.
3. Mount the stock air box.

#### D. 5.7L & 6.1L AIR FILTER BRACKET

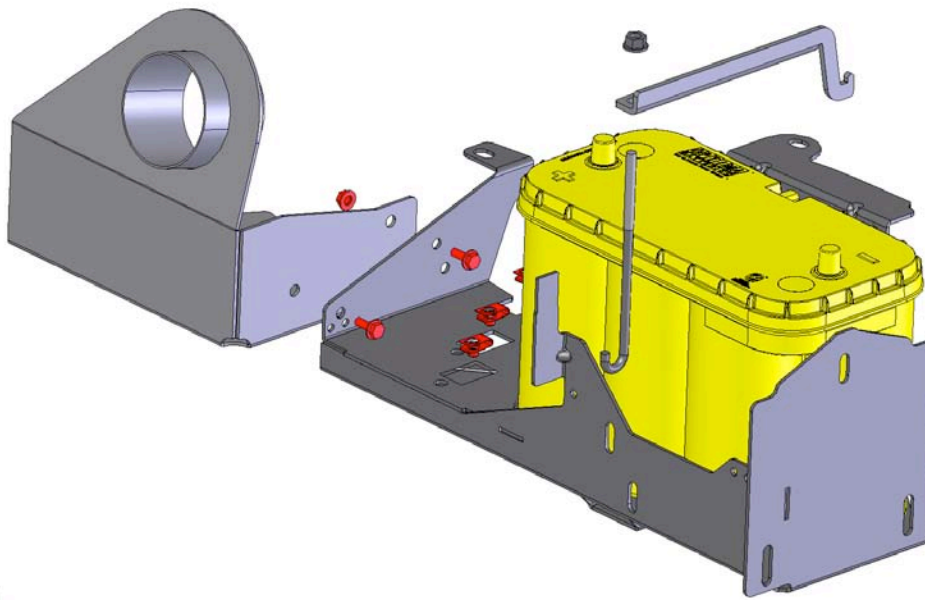

1. Using the filter bracket supplied with the HEMI kit, mount the bracket to the front of the battery tray and to the front of the vehicle as shown. Install the bolts from inside the battery tray outward.
2. Mount the supplied K&N air filter to the bracket. (K&N #RC-4630)









AMERICAN EXPEDITION  
VEHICLES

---

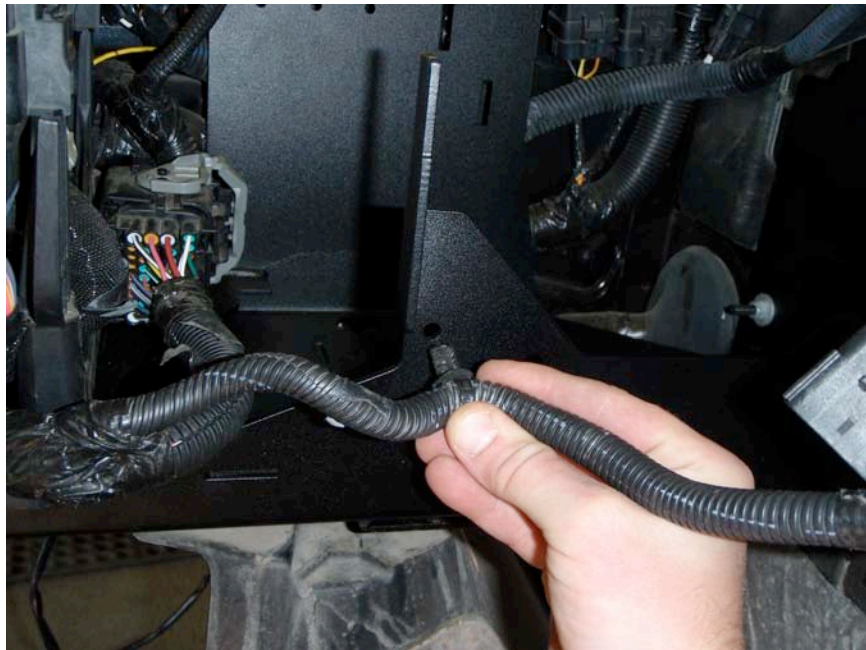



AMERICAN EXPEDITION  
VEHICLES

---





A M E R I C A N   E X P E D I T I O N  
V E H I C L E S

---





A M E R I C A N   E X P E D I T I O N  
V E H I C L E S

---

## **COMMENTS OR QUESTIONS?**

### **American Expedition Vehicles**

Phone: 406.251.2100

Email: [tech@aev-conversions.com](mailto:tech@aev-conversions.com)

Website: <http://www.aev-conversions.com>





A M E R I C A N   E X P E D I T I O N  
V E H I C L E S

---

# **JK V8 HEMI® BUILDER KIT**

## **Plumbing**

### **Installation Guide**

5.7L, 6.1L WK or XK Powertrains w/AC Pump (55111414AA)  
and Power Steering Pump (5290778AA)  
07+ JK – SWB or LWB, LHD only



## A. AEV HEMI FUEL LINE

1. Remove the locking clip out of the plastic fuel line at the tank as shown.
2. Install the stud provided into the 5-45 transmission and reuse the steel fuel line bracket from the 3.8L engine.
3. Install the AEV Fuel Line; be sure to lubricate all tubes or hoses prior to installation in order to avoid damaging seals.

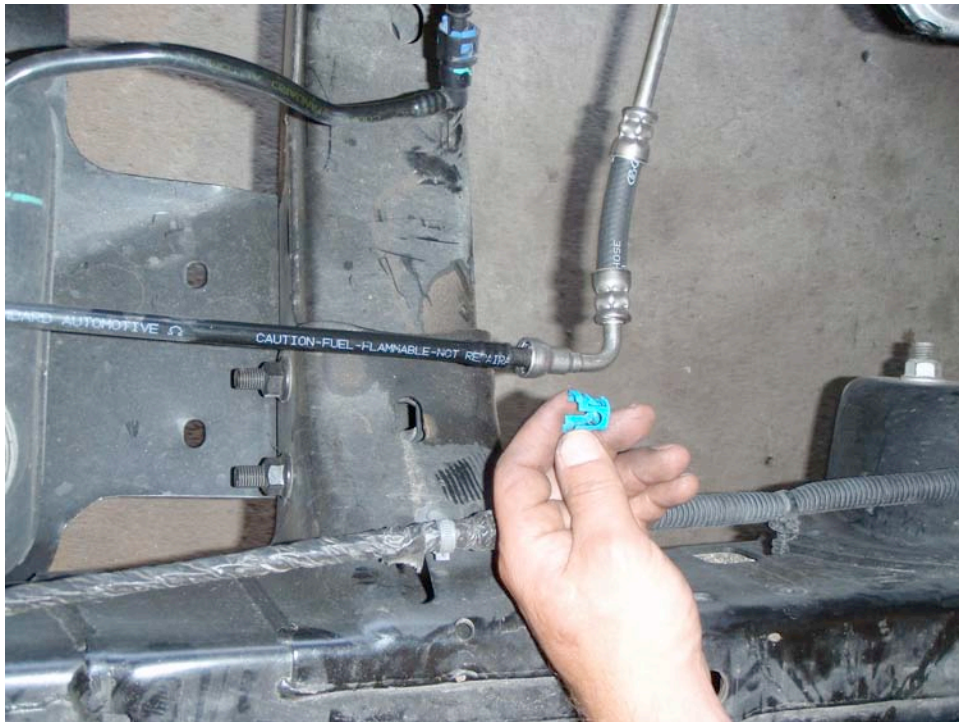



AMERICAN EXPEDITION  
VEHICLES

---







## **B. POWER STEERING LINES**

1. This step is to be performed after the powertrain has been installed.
2. Be sure you are using the correct power steering pump (Mopar #5290778AA)
3. Install the lines as shown.
4. Be sure to lubricate all O-rings prior to assembly.



## **C. AEV AC LINES (BODY SIDE)**

1. Install the liquid line (Condenser to Firewall). Use the stock hardware to connect the lines.
2. Fasten the line to the ground stud located on the left fender structure immediately behind the ABS module using the supplied clip.
3. Be sure to lubricate all O-rings prior to assembly.

## **D. AEV AC LINES (POWERTRAIN SIDE)**

1. Be sure the correct AC compressor is being used (Mopar #55111414AA)
2. Install the suction line (Compressor to Firewall) onto the compressor using stock hardware. The firewall side will be installed when the body is mated to the chassis.
3. Install the AC Discharge line (Compressor to Condenser) to the compressor using the stock hardware. Install the stock pressure transducer. The condenser side will be installed when the body is mated to the chassis.
4. Be sure to lubricate all O-rings prior to assembly.



## **E. AEV TRANSMISSION COOLER**

1. Install the transmission cooler to the AC condenser as shown. Locate the cooler 3.5" from the top of the condenser and 3.5" from the right side of the condenser. Pre-install transmission cooler hose on each barb of the transmission cooler.
2. Using the Mopar 55038175AA Transmission Cooler lines remove the OE hose portion as shown. Connect the Transmission Cooler lines to the transmission Cooler once the body is mated to the chassis.

## **F. HEATER HOSES**

1. Cut the stock 3.8L hoses as shown and fit to the completed powertrain before mating the body to the chassis.

## **G. EVAPORATIVE PURGE VALVE HOSES**

1. Reuse the stock 3.8L hose from the fuel tank to the purge valve. Attach this line to the fuel line using the stock bracket and a couple zip ties.
2. Use Mopar part #4578627AA hose to go from the intake, around the engine to the purge valve. This hose doesn't quite go all the way to the purge valve; you will need to use a portion of the stock 3.8L purge valve line from the purge valve to the engine.

## **H. RADIATOR HOSES**

1. Install the upper and lower radiator hoses as shown.
2. Trim the corner off of the fan shroud in order to clear the lower radiator hose.



A M E R I C A N   E X P E D I T I O N  
V E H I C L E S

---

## COMMENTS OR QUESTIONS?

### **American Expedition Vehicles**

Phone: 406.251.2100

Email: [tech@aev-conversions.com](mailto:tech@aev-conversions.com)

Website: <http://www.aev-conversions.com>



A M E R I C A N   E X P E D I T I O N  
V E H I C L E S

---

# **JK V8 HEMI® BUILDER KIT**

## **Exhaust**

### **Installation Guide**

5.7L, 6.1L WK or XK Powertrains w/Grand Cherokee or Commander Manifolds  
07+ JK - SWB, LWB



AEV's HEMI exhaust is designed specifically for the 5.7L HEMI but can be used on the 6.1L engine if the 5.7L manifolds, gaskets and bolts are used. The exhaust is designed around the stock suspension and bumpers and may need to be modified to accommodate aftermarket suspensions, bumpers or other accessories.

**DO NOT TIGHTEN ANY PART OF THE EXHAUST SYSTEM UNTIL THE FINAL DESIRED FIT IS ACHIEVED!**

1. Install the tailpipe section and isolator.
2. Install the muffler section.
3. Install the downpipes and catalytic converters.
4. Install the hanger mount into the existing cross member hole behind the muffler.
5. Adjust for clearances paying particular attention to the area around the front driveshaft, JK cross member, transmission pan, rear track bar and rear bumper. Once everything is adjusted properly, the clamps can all be tightened.
6. The right hand down tube that goes under the transmission oil pan should be parallel with the JK cross member when fitted properly.
7. You may wish to tack weld all joints for increased durability.
8. Install the star washers on the three isolator hangers.





AMERICAN EXPEDITION  
VEHICLES

---

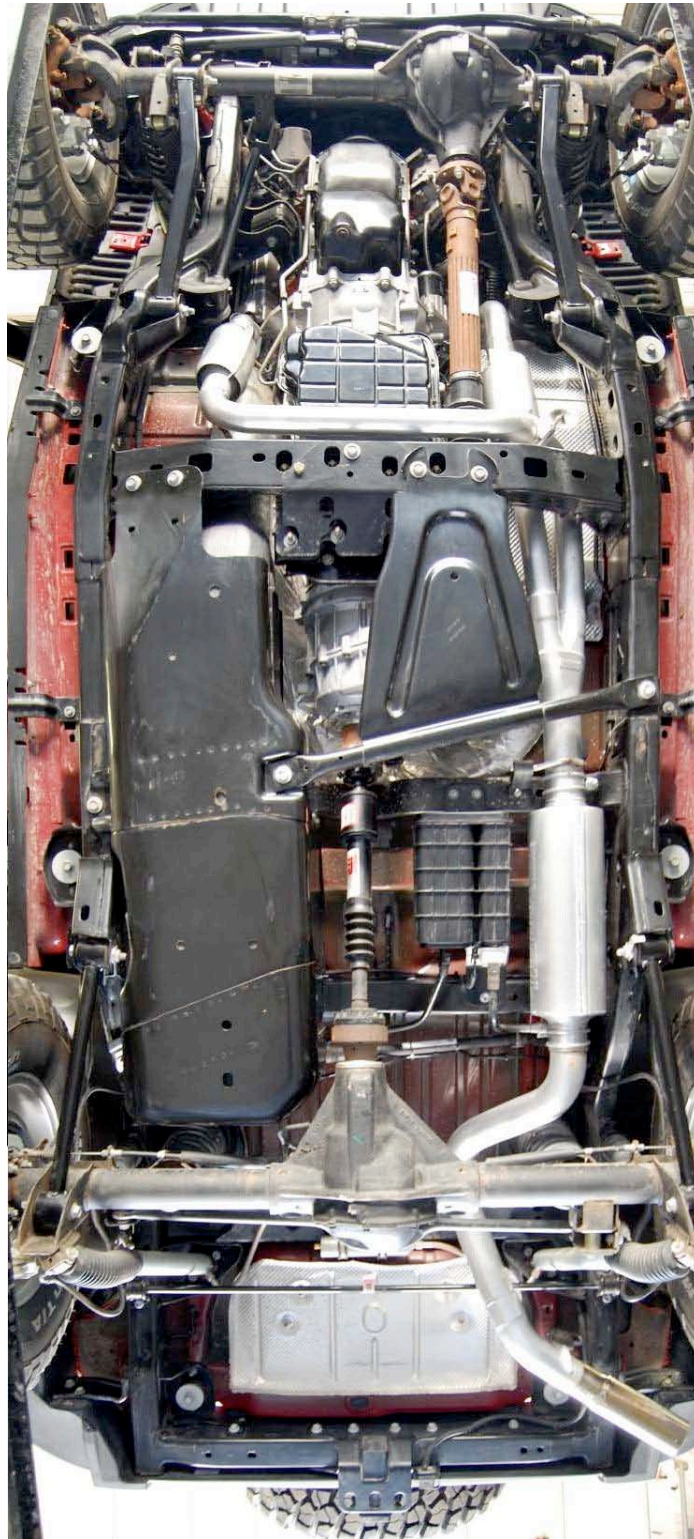

**Note:** 2DR Shown, 4DR Similar



A M E R I C A N   E X P E D I T I O N  
V E H I C L E S

---



**Note:** 2DR Shown, 4DR Similar



A M E R I C A N   E X P E D I T I O N  
V E H I C L E S

---

## COMMENTS OR QUESTIONS?

### **American Expedition Vehicles**

Phone: 406.251.2100

Email: [tech@aev-conversions.com](mailto:tech@aev-conversions.com)

Website: <http://www.aev-conversions.com>



## AEV SRA INTAKE FOR 5.7L AND 6.4L ENGINES

PN: AEV30206AA

1. This intake must be used in conjunction with an AEV PCM that has been programmed to take full advantage of the long and short runners.
2. Use the 6.4L throttle body only.
3. *Do not use the throttle body screws that come with the 6.4L engine. Only use the throttle body screws supplied with your AEV intake. FAILURE TO USE THE CORRECT SCREWS WILL BREAK THE INTAKE MANIFOLD AND VOID YOUR AEV WARRENTY.*
4. There are 10 seals on the bottom of the manifold, one between the intake manifold actuator and intake, and one between the throttle body and the intake. Be sure all seals are installed.
5. The intake tube from the air filter to the throttle body must be trimmed as shown below. (Remove grey portion) **IMPORTANT: IF INSTALLING A 5.7L ENGINE, ONLY TRIM INTAKE TUBE IF USING THE 6.4L INTAKE.**

