

INSTALLATION INSTRUCTION



Suspension System RS66103 (B)

(4" TRAIL SYSTEM)

2012 JEEP MODELS EQUIPPED WITH 3.6L V6 ENGINE NEED EXHAUST MODIFICATION KIT RS720003.
OR REPLACEMENT FRONT DRIVESHAFT (DRIVESHAFT / EXHAUST CLEARANCE ISSUE).



Jeep Wrangler (JK)
2007 - 2012

IMPORTANT NOTES!

WARNING: This suspension system will enhance the off-road performance of your vehicle. It will handle differently, both on and off-road, from a factory equipped passenger car or truck. Extreme care must be used to prevent loss of control or vehicle rollover during abrupt maneuvers. Failure to drive this vehicle safely may result in serious injury or death to the driver and passengers. ALWAYS WEAR your seat belts, REDUCE your speed, and AVOID sharp turns and other abrupt maneuvers.

A. Before installing this system, have the vehicle's alignment and frame checked at a state approved facility. The alignment must be within factory specifications and the frame must be sound (no cracks, damage, or corrosion).

B. Do not install a body lift kit with Rancho's suspension system or interchange parts from this system with components from another manufacturer. Use the following Rancho shock absorbers with this system:

RS5000 / RS9000X

<u>Front</u>	<u>Rear</u>
RS5329	RS5330
RS999329	RS999330

C. Compare the contents of this system with the parts list in these instructions. If any parts are missing, including fasteners, contact the Rancho Technical Department at 1-734-384-7804. Each hardware kit in this system contains fasteners of high strength and specific size. Do not substitute a fastener of lesser strength or mix one hardware kit with another.

D. Apply **THREAD LOCKING COMPOUND** to all bolts during installation. One drop on the exposed threads of each bolt before installing the nut is sufficient to provide an adequate bond. **CAUTION:** Thread locking compound may irritate sensitive skin. Read warning label on container before use.

E. Install all nuts and bolts with a flat washer. When both SAE (small OD) and USS (large OD) washers are used in a fastener assembly, place the USS washer

against the slotted hole and the SAE washer against the round hole.

F. Unless otherwise specified, tighten all bolts to the standard torque specifications listed at the end of the note's section. **USE A TORQUE WRENCH** for accurate measurements.

G. Rancho parts come with a protective coating. Do not powder coat, chrome, cadmium, or zinc plate any of the components in this system. If you wish to change the appearance of components enamel paint can be applied over the original coating.

H. Do not weld anything to these components, and do not weld any of these components to the vehicle unless specifically stated in the instructions. If any component breaks or bends, contact your local Rancho dealer or Rancho for replacement parts.

I. Some of the service procedures require the use of special tools designed for specific procedures. The following tools and supplies are recommended for proper installation of this kit.

- Jeep Service Manual
- Torque Wrench (250 FT-LB capacity)
- Hammer
- 1/2" Drive Ratchet and Sockets
- Combination Wrenches
- 3/8-16 Tap
- File
- Hydraulic Floor Jack
- Heavy Duty Jack stands
- Wheel Chocks (Wooden Blocks)
- Safety Glasses**--Wear safety glasses at all times

J. It is extremely important to replace torsion bars, CV flanges, and front drive shaft/pinion relationships as original. Be sure to mark left/right, front/rear, and indexing of mating parts before disassembly. A paint marker or light colored nail polish is handy for this.

K. Suspension components that use rubber or urethane bushings should be tightened with the vehicle at normal ride height. This will prevent premature failure of the bushing and maintain ride comfort.

L. This suspension system was developed using a BF Goodrich® Mud-Terrain™ T/A® KM-35 x 12.50 x 18 D tire on an 18" x 9" wheel with 4.5" of backspacing. Total backspacing is 5.9". Before installing any other combination, consult your local tire and wheel specialist. **Actual tire size varies by manufacturer.**

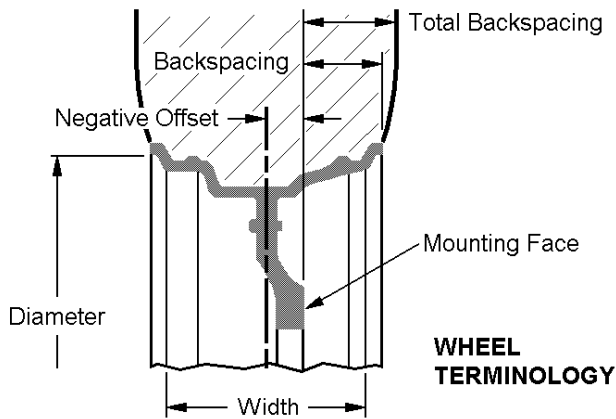

WHEEL TERMINOLOGY

M. The required installation time for this system is approximately 4 hours. Check off the box () at the beginning of each step when you finish it. Then when you stop during the installation, it will be easier to find where you need to continue from.

N. Welding on a vehicle creates an electrical charge throughout the body and frame. Disconnect the vehicle's battery prior to any welding. Place welding ground clamps as near as possible to the weld. Never use a vehicle suspension component as a welding ground point.

O. Important information for the end user is contained in the consumer/installer information pack. If you are installing this system for someone else, place the information pack on the driver's seat. Please include the installation instructions when you finish.

P. Thank you for purchasing the best suspension system available. For the best installed system, follow these instructions. If you do not have the tools or are unsure of your abilities, have this system installed by a certified technician. RANCHO IS NOT RESPONSIBLE FOR DAMAGE OR FAILURE RESULTING FROM AN IMPROPER INSTALLATION.

Compatible With OE Wheels	Development Tire Size (actual)	Optional Tire Size ² (actual)	Wheel Size (backspacing)
Yes ¹	35x12.5xR17 (34.8"x12.5")	37x12.5xR17 (36.3"x12.8")	17x9 (4.5")

¹ OE wheels compatible with stock size tires only.

² Fitment of the optional tire size may require trimming to provide proper clearance.

STANDARD BOLT TORQUE SPECIFICATIONS						
INCH SYSTEM			METRIC SYSTEM			
Bolt Size	Grade 5	Grade 8	Bolt Size	Class 9.8	Class 10.9	Class 12.9
5/16	15 FT-LB	20 FT-LB	M6	5 FT-LB	9 FT-LB	12 FT-LB
3/8	30 FT-LB	35 FT-LB	M8	18 FT-LB	23 FT-LB	27 FT-LB
7/16	45 FT-LB	60 FT-LB	M10	32 FT-LB	45 FT-LB	50 FT-LB
1/2	65 FT-LB	90 FT-LB	M12	55 FT-LB	75 FT-LB	90 FT-LB
9/16	95 FT-LB	130 FT-LB	M14	85 FT-LB	120 FT-LB	145 FT-LB
5/8	135 FT-LB	175 FT-LB	M16	130 FT-LB	165 FT-LB	210 FT-LB
3/4	185 FT-LB	280 FT-LB	M18	170 FT-LB	240 FT-LB	290 FT-LB

BOLT IDENTIFICATION	
<p>1/2-13x1.75 HHCS</p> <p>D T L X</p> <p>G = Grade Marking (bolt strength) L = Length (inches) D = Nominal Diameter (inches) X = Description (hex head cap screw) T = Thread Pitch (threads per inch)</p>	<p>M12-1.25x50 HHCS</p> <p>D T L X</p> <p>P = Property Class (bolt strength) L = Length (millimeters) D = Nominal Diameter (millimeters) X = Description (hex head cap screw) T = Thread Pitch (thread width, mm)</p>



PARTS LIST

<u>P/N</u>	<u>DESCRIPTION</u>	<u>QTY.</u>	<u>P/N</u>	<u>DESCRIPTION</u>	<u>QTY.</u>
	Box 1 of 2		860714	Articulation Bushing Kit	1
176645	Lower Suspension, Front	2	420080	Sleeve	8
176646	Lower Suspension, Rear	1	520080	Bushing	16
176659B	Adjustable Front Track Bar	1	860613	Shim Kit	2
176088B	Sway Bar End Link, Front	2	78520	Washer	12
170110	Brake Line, Left Front	1	860575	Rear Track Bar Hardware Kit	1
170113	Brake Line, Right Front	1	420067	Sleeve	1
176655B	Axle Track Bar Bracket, Rear	1		M12-1.75 x 30 HHCS	1
176442	Brake Line Bracket, Rear	2		M12-1.75 Stover Nut	1
176443	Bump Stop Spacer, Front	2		M12 Washer	2
176444	Bump Stop Spacer, Rear	2		M14-2.00 x 80 HHCS	1
176445	Sway Bar Bracket, Rear	2		M14-2.00 Stover Nut	1
860709	Adjustable Track Bar Hardware Kit	1		M14 Washer	2
602618	Rod End, 9/16 – 3/4	1		1/4-20 x .75 HHCS	4
	Sleeve	1		1/4-20 Stover Nut	4
	Track Bar Bushing	2		1/4 Washer	8
	Jam Nut, 3/4-16	1		M10-1.5 x 50 HHCS	4
860713	Track Bar Axle Bracket, Rear Hardware Kit	1		M10 Washer	4
	U-Bolt, 3/8-16	1		M8-1.25 x 20 HHCS	4
	Nut, 3/8-16 NyLock Nut	2		M8-1.25 Nylock Nut	4
	Washer 3/8 SAE	2		M8 Washer	8
	M10-1.25 x 25 HHCS	2	94180	Information Pack	1
	M10-1.25 Nut	2	780281	Rancho Decal	1
	M10 Washer	4	89103	Instructions	1
	M14-1.50 x 80 HHCS	1	94119	Consumer/Warranty Information	1
	M14-1.50 NyLock Nut	2	94177	Warning Sticker	1
	M14 Washer	3		Box 2 of 2	
	Spacer	1	822B	Front Coil Spring	2
			817B	Rear Coil Spring	2

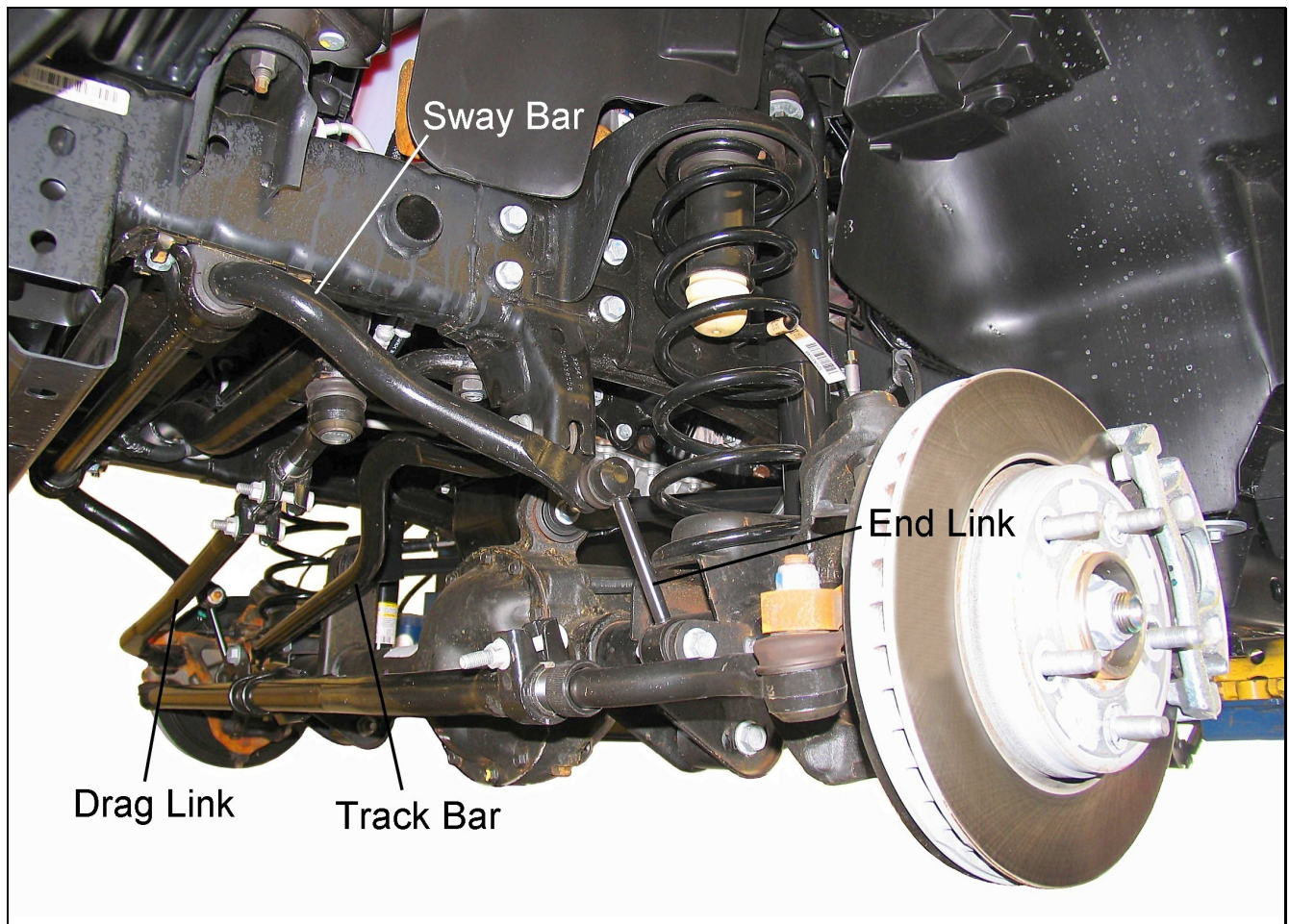

Front Suspension

FRONT SUSPENSION

SHOCK ABSORBER & COIL SPRING REMOVAL

- 1) Park vehicle on a level surface. Set the parking brake and chock rear wheels. Disconnect the negative ground cable from the battery.
- 2) Remove the track bar to frame bracket nut and bolt.
- 3) Raise the front of the vehicle and support the frame with jack stands. Remove the front wheels and set them aside.
- 4) Support the front axle with a floor jack.
- 5) Disconnect the end links from the axle brackets.
- 6) Remove the shock absorber upper nut, retainer, and bushing.

- 7) Remove the shock absorber lower nut and bolt. Remove the front shock absorber.
- 8) Repeat steps 6 and 7 for the other side. **DO NOT REUSE ORIGINAL SHOCK ABSORBERS.**
- 9) Remove bolts and separate the brake hoses from the frame rails. If necessary, disconnect any vent hoses and electrical wiring from the axle.
- 10) Carefully lower the front axle and remove the coil springs. Push down on axle if necessary.

CAUTION: Do not allow the front axle to hang by any hoses or cables.

SUSPENSION ARM REPLACEMENT

- 1) Support the front axle with a jack.
- 2) Remove the driver side lower suspension arm from the frame and axle brackets. See Illustration 1.

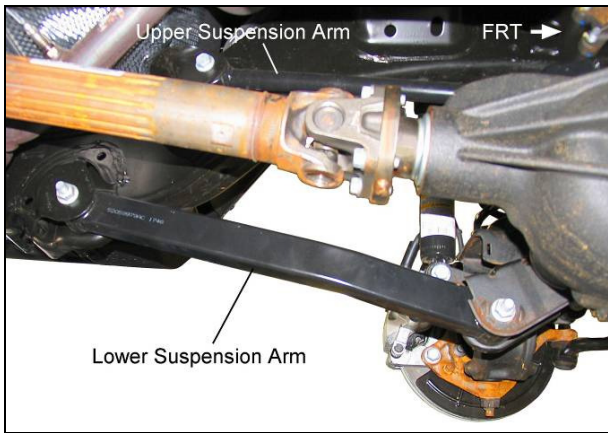

Illus. 1

- 3) Lubricate two bushings (520080) and a sleeve from kit 860714 with synthetic lithium grease. Insert bushings and sleeve into the front barrel of lower suspension arm 176645. See illustration 2.

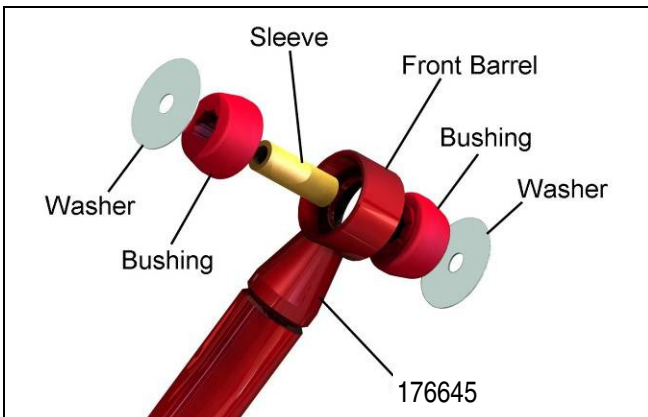

Illus. 2

- 4) Apply a film of grease to the outside of the installed bushings. Place a washer from kit 860714 against each bushing. Attach the front barrel assembly to the driver side axle bracket with the original hardware. See illustration 3.



Illus. 3

- 5) Attach the rear barrel assembly to the frame bracket with the original hardware. Tighten nuts and bolts to 125 ft. lbs.
- 6) Repeat steps 2 through 5 for the other side.

BUMP STOP SPACER, COIL SPRING & SHOCK ABSORBER INSTALLATION

- 1) Reference mark the drive shaft to the front differential. Disconnect the drive shaft from the differential. Support drive shaft with a tie wrap or wire.
- 2) Drill a 5/16" hole through the center of the coil spring axle pad. For ease of installation, tap the hole (3/8-16).
- 3) Install original insulator on top of coil spring 822B. Place bump stop spacer 176443 inside the coil spring.
- 4) Insert the spring assembly into the upper pocket and onto the axle pad. See illustration 4. Align pig tail with groove in axle pad.
- 5) Attach the bump stop spacer to the axle pad with the self-tapping screw from kit 860574.
- 6) Repeat steps 2 through 5 for the other side.
- 7) Install retaining washer and bushing on NEW shock absorber, insert shock into upper mounting hole. Install bushing, washer and nut. Tighten nut to 17 ft. lbs. Repeat for other side.

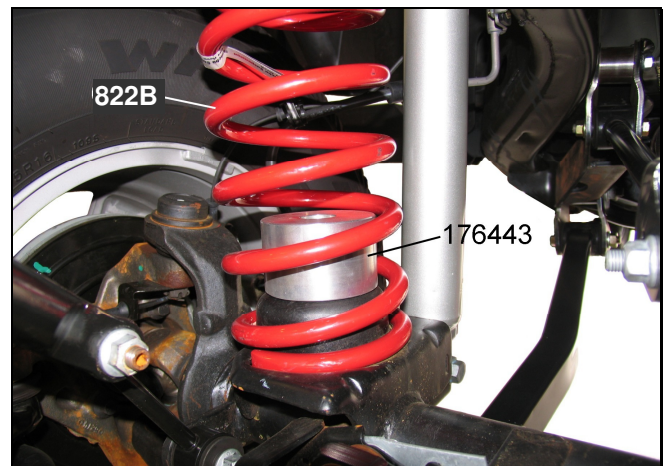

Illus. 4

- 8) Raise front axle and attach shock lower mounts to axle brackets with the original hardware. Tighten nuts and bolts to manufacturer's specifications.
- 9) Reattach drive shaft to front differential. Tighten bolts to manufacturer's specifications.

- 10) Reattach vent hose and electrical wiring if necessary.

ADJUSTABLE TRACK BAR INSTALLATION.

- 1) Remove Track Bar axle nut & bolt. Remove OE Track Bar.
- 2) Insert bushing and sleeve from hardware kit 860709 into adjustable track bar 176659B. Insert Heim end with Jam nut in other end. Adjust to approx. 33.10 Inches center to center.
- 3) Install adjustable track bar 176659B Heim end side into the original track bar frame bracket using original hardware. See illustration 5.

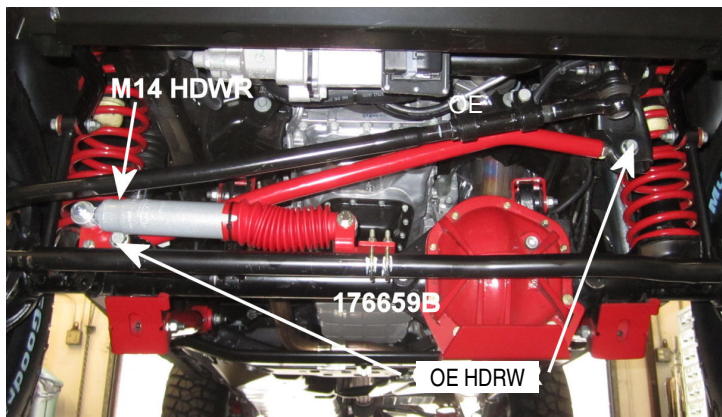

Illus. 5

- 4) Install adjustable track bar 176659B bushing end into axle mount using original hardware. If holes do not line up, bolt may be inserted easier when vehicle is on the ground at ride height.

NOTE: Do not tighten the track bar to brackets bolts until the vehicle is at normal ride height.

Periodically check track bar mounting bolts for tightness.

SWAY BAR END LINK INSTALLATION.

- 1) Using a silicone spray, insert the supplied bushings and sleeves into new end links (176088b).
- 2) Attach end links to sway bar with the original bolts and large USS washers from hardware kit 860412. See illustration 6.
- 3) Attach end links to axle brackets with the hardware from kit 860412. Tighten nuts and bolts to specifications. See illustration 6.

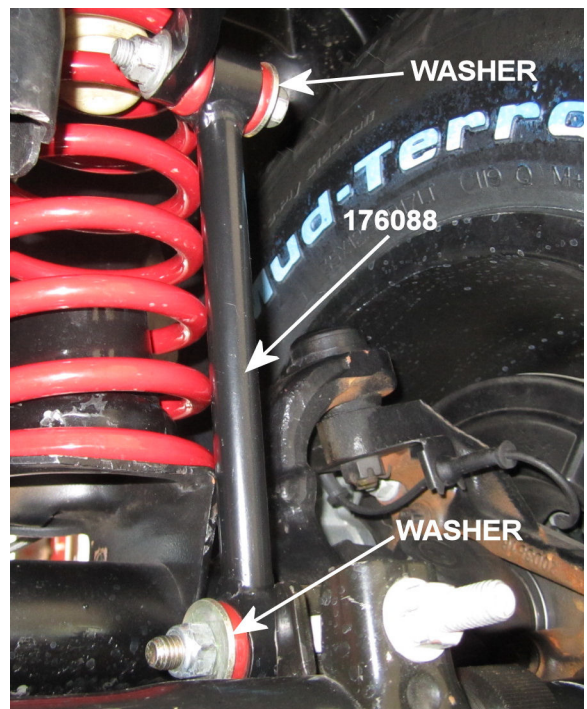

Illus. 6

BRAKE HOSE REPLACEMENT

NOTE: To keep the brake bleeding process to just the front brakes, do not allow the brake fluid to drain completely from the master cylinder reservoir.

- 1) Separate the driver side ABS line from the brake hose.
- 2) Remove brake hose to axle bracket bolts.
- 3) Separate the driver side brake hose from the brake tube and frame rail. Plug tube to prevent brake fluid leakage.
- 4) Remove the brake hose from the caliper. Discard copper washers.
- 5) Attach left brake hose 170110 to the caliper with the supplied banjo bolt and new copper washers.
- 6) Attach left brake hose to the frame rail with the original bolt. Attach brake tube to hose. Tighten brake tube fitting to 18 ft. lbs. See illustration 7.

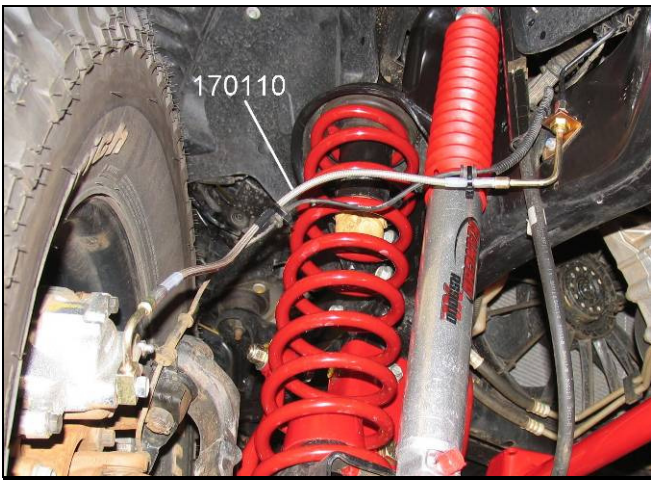

Illus. 7

- 7) Slide grommets on ABS wire to provide slack for full suspension/turning movement. Reattach ABS wires to brake lines.
- 8) Repeat steps 1 through 7 to install right brake hose 170113 on the passenger side.
- 9) Bleed front brakes.
- 10) Install front wheels and lower vehicle to the ground. Tighten lug nuts to 80--110 ft. lbs.
- 11) Tighten the Track bar nut and bolt to 125 ft. lbs.

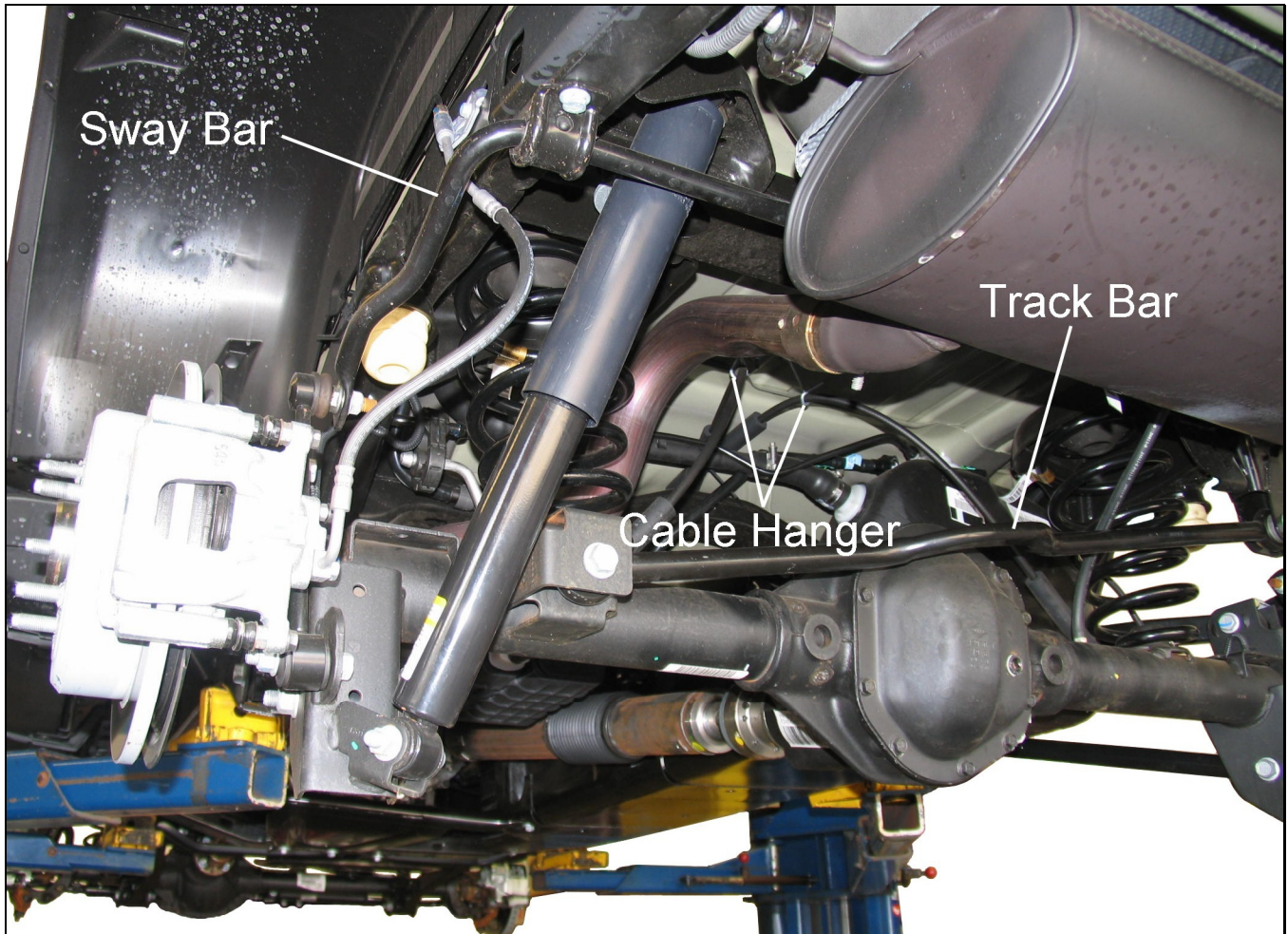

Rear Suspension

REAR SUSPENSION

SHOCK ABSORBER & COIL SPRING REMOVAL

- 1) Remove rear track bar to frame bracket mounting bolt.
- 2) Chock front wheels. Raise the rear of the vehicle and support the frame with jack stands. Remove the rear wheels.
- 3) Support the rear axle with a floor jack
- 4) Disconnect the end links from the sway bar.
- 5) Remove bolts and separate the brake hoses from the frame rails. If necessary, disconnect any vent hoses and electrical wiring from the axle.
- 6) Remove the nuts from the parking brake cable hanger above the rear axle. Remove the hanger from the cables.
- 7) Remove the shock absorber upper mounting bolts. Remove the lower nut and bolt from the axle bracket. Remove the shock absorber. Repeat for other side.
- 8) Carefully lower the rear axle until the coil springs are free from the upper mount seat. Remove the coil springs.

CAUTION: Do not allow the axle to hang by any hoses or cables.

COIL SPRING & SHOCK ABSORBER INSTALLATION

- 1) Place the new coil springs (817B) onto the axle pads. Align upper pigtails towards the front of the vehicle. Raise the axle until the coil springs seat on the upper isolators. See illustration 8.

NOTE: When installing coil springs, make sure the rubber isolator is positioned in the upper mount and the small egg-shaped coil end is at the bottom.

- 2) Attach new Rancho rear shocks to the upper mounting brackets with the original bolts. Tighten bolts to 23 FT-LBS.

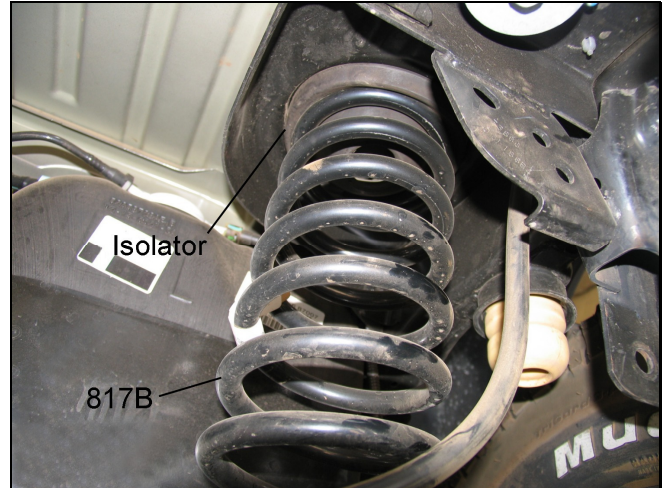

Illus. 8

- 3) Loosely attach shocks to the axle brackets with the original hardware.

REAR TRACK BAR AXLE BRACKET INSTALLATION.

- 1) Remove rear track bar from rear axle bracket. See illustration Rear Suspension (page 8).
- 2) Place track bar bracket 176655B over the original rear axle bracket. The new bracket should fit on top of the original bracket.
- 3) Insert the sleeve 420067 from kit 860713 and attach track bar bracket 176655B to the rear axle bracket with the M14-1.50 X 80mm hardware thru bottom OE hole. See illustration 9.

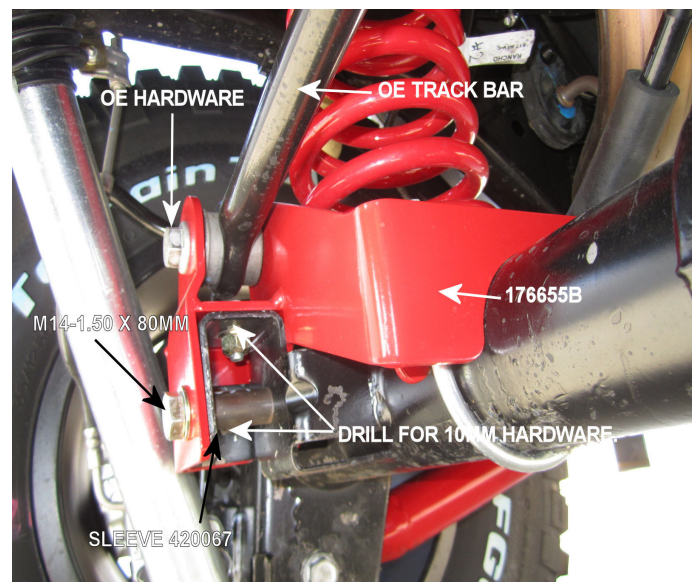

Illus. 9

- 4) Use two clamps to hold bracket 176655B snug to axle bracket. Using a transfer punch or center punch, mark the center of the two 10mm holes in the OE axle bracket using bracket 176655B as template.
- 5) Drill both holes with 10mm drill (3/8 drill), and install the 2 supplied M10 hardware from kit 860713.
- 6) Using the U-Bolt from hardware kit 860713, attach the top of bracket 176655B to the rear axle tube using 3/8 washer and NyLock nuts. At this time just snug down attached hardware. Do not torque down.
- 7) Torque M10 hardware. Torque M14 hardware. Torque U-bolt.
- 8) Reinstall OE track bar and reuse OE hardware in both ends, replace OE nut plate with lock nut on axle end. If holes do not line up, bolt may be inserted easier when vehicle is on the ground at ride height.

NOTE: Do not tighten the track bar to brackets bolts until the vehicle is at normal ride height.

SWAY BAR & BRAKE LINE BRACKET INSTALLATION

- 1) Disconnect the sway bar from the frame rail.
- 2) Insert sway bar bracket 176445 between the sway bar and the frame rail. See illustration 10.

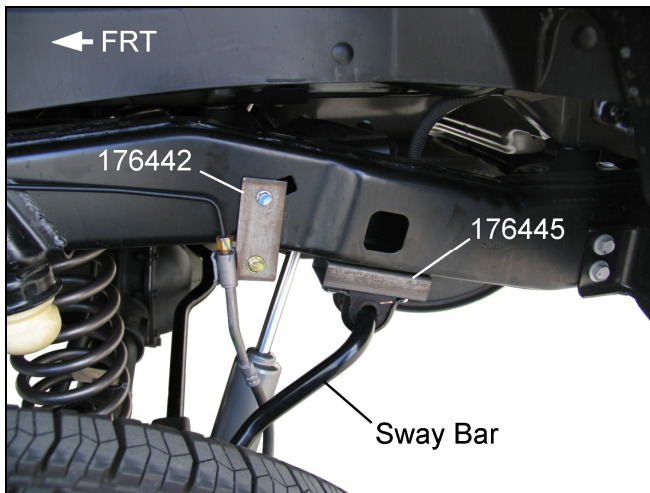

Illus. 10

- 3) Attach sway bar to frame rail with the 10mm hardware from kit 860575. Tighten bolts to 35 ft lbs.
- 4) Attach brake line bracket 176442 to the frame rail with the original brake line bolt. See illustration 10.

- 5) Attach brake line to the inside of bracket 176442 with the 1/4" hardware from kit 860575. Tighten nuts and bolts to 12 ft lbs.
- 6) Repeat steps 1 through 5 for other side.
- 7) Reattach end links to sway bar. Tighten nuts to 40 ft. lbs.

BUMP STOP BRACKET INSTALLATION

- 1) Using the original holes on the axle pad, attach bump stop bracket 176444 to the axle with the 8mm hardware from kit 860575. See illustration 11.
- 2) Repeat for other side.



Illus. 11

- 3) Install rear wheels and lower vehicle to the ground. Tighten lug nuts to 80-110 FT-LBS.
- 4) Tighten the track bar bolts to 125 ft. lbs. Tighten the shock absorber lower mounting bolts to 74 ft. lbs.
- 5) Reconnect the battery ground cable.

FINAL CHECKS & ADJUSTMENTS

- 1) **ATTENTION:** To ensure that the ESP system operates correctly, the steering wheel needs to be re-centered when vehicle returns to ground. To reposition the front wheels and steering wheel turn the drag link adjustment sleeve in desired direction. Adjustment sleeve bolts must face forward for good clearance. See illustration Front Suspension. (page 5)

- 2) Turn the front wheels completely left then right. Verify adequate tire, wheel, brake hose and ABS wire clearance. Inspect steering and suspension for tightness and proper operation.
- 3) With the suspension at maximum extension (full droop), inspect and rotate all axles and drive shafts. Check for binding and proper slip yoke insertion. The slip yoke should be inserted a minimum of one inch into the transfer case and/or transmission.
- 4) Ensure that the vehicle brake system operates correctly. If new brake hoses were installed, verify that each hose allows for full suspension movement.
- 5) Readjust headlamps. Have vehicle Aligned to manufacturer's specifications.

Alignment Specifications

Adjustment	Preferred	Range
Caster	4.6°	±1.0°
Camber (fixed angle)	-0.25°	±0.63°
Toe-In (each wheel)	0.15°	±0.15°
Thrust Angle	0	±0.15°

NOTE: Castor alignment cams are recommended.

Please retain this publication for future reference. See Important Note O.

2012 Exhaust modification, crossover pipe with clamps:

Rancho part number: RS720003

Replacement drive shafts:

During high articulation events, the front driveshaft may contact exhaust or transmission oil pan. A smaller diameter drive shaft is suggested for optimal performance.

Rancho recommends Powertrain Industries drives shafts:

2007 – 2011 Models:

Front drive shaft 2dr / 4dr Part Number: 3194-1925
 Rear drive shaft 4dr Part Number: 3194-2750
 Rear drive shaft 2dr Part Number: 3194-0725

2012 Models:

Front drive shaft 2dr / 4dr Part Number: 3194-2125
 Rear drive shaft 2dr Part Number: 3194-0475
 Rear drive shaft 4dr Part Number: 3194-2550

Powertrain Industries, Garden Grove, CA.

1-800-798-4585.