

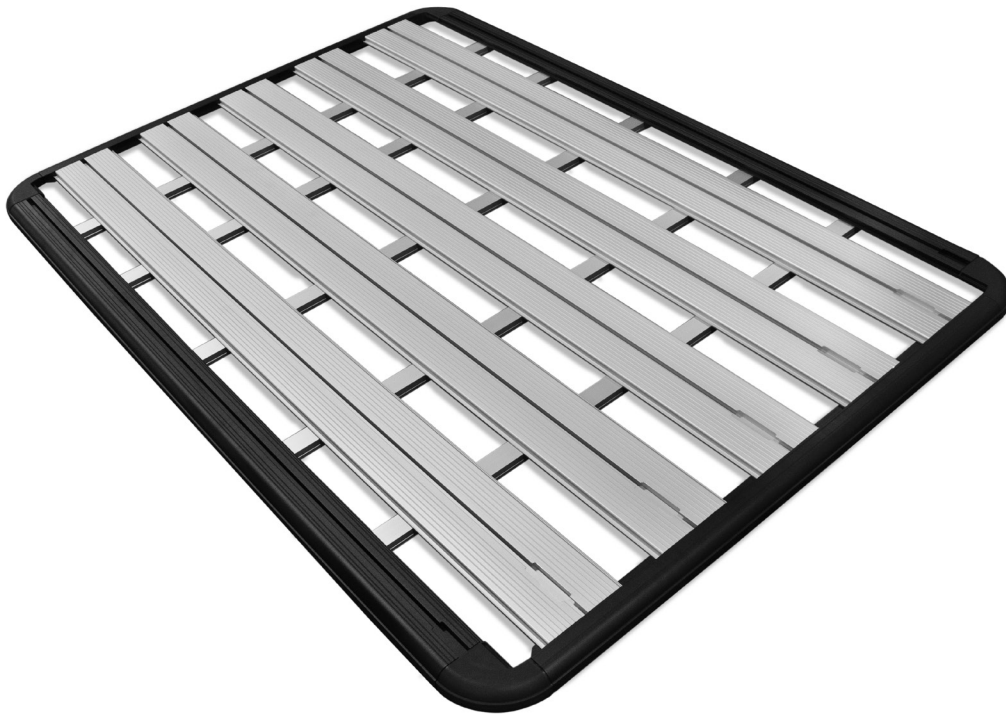

# ROOF RACK



AEV30209AA  
*Last Updated: 10/16/12*

INSTALLATION GUIDE



## NOTE: ROOF RACK MAY DEGRADE SATELLITE RADIO RECEPTION

### PLEASE READ BEFORE YOU START

TO GUARANTEE A QUALITY INSTALLATION, WE RECOMMEND READING THESE INSTRUCTIONS THOROUGHLY BEFORE BEGINNING ANY WORK. THESE INSTRUCTIONS ASSUME A CERTAIN AMOUNT OF MECHANICAL ABILITY AND ARE NOT WRITTEN NOR INTENDED FOR SOMEONE NOT FAMILIAR WITH AUTO REPAIR.

| INCLUDED PARTS             | QTY | REQUIRED TOOLS   |
|----------------------------|-----|------------------|
| Aluminum Planks            | 5   | Basic hand tools |
| Right Side Rail            | 1   | Rivet gun        |
| Left Side Rail             | 1   |                  |
| End Rails                  | 2   |                  |
| Corners                    | 4   |                  |
| Corner Closeout Plate      | 4   |                  |
| Corner End Rail Connectors | 4   |                  |
| Aluminum Crossbars         | 5   |                  |
| Roll Bar Brackets          | 4   |                  |
| Satellite Antenna Bracket  | 1   |                  |
| Stantion Assemblies        | 4   |                  |
| AEV logo Decal             | 4   |                  |
| Alcohol Swab               | 1   |                  |
| Hardware                   |     |                  |

Note: The included parts shown below are not necessary for this application and may be discarded.





## PART I. PLATFORM ASSEMBLY

### A. ASSEMBLE OUTER FRAME

1. Attach corner close out plates to bottom of corner pieces using the supplied screws (Fig. 1).
2. Assemble all four corners as shown in Figure 2.  
Do not fasten with screws at this point.

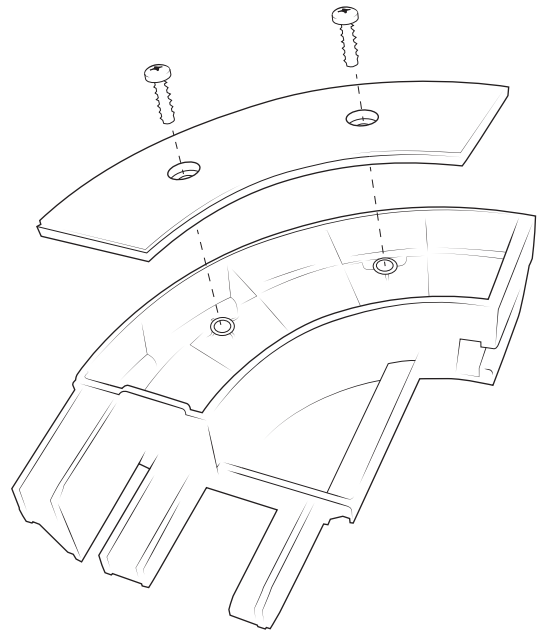

Figure 1

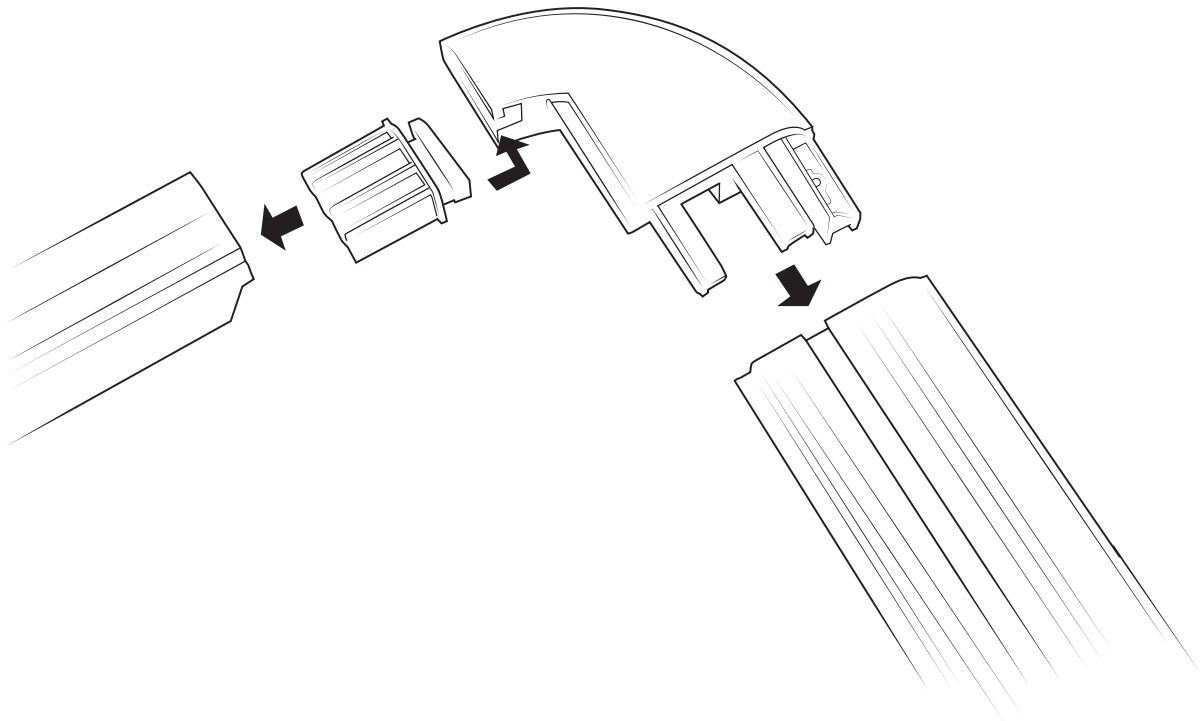
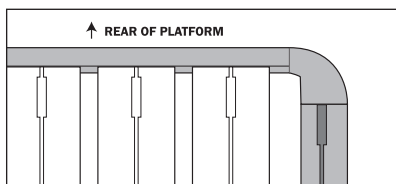

Figure 2



## B. PLANK ASSEMBLY

1. Carefully place outer frame upside down on a clean, flat surface.
2. Slide the platform planks under the frame one end at a time being careful not to scratch the surface of the frame. **NOTE: Make sure to run the planks all in the same direction so that all of the channel cutouts are on the same end as the cutouts in the frame rail.**



3. Lower the crossbars into the tray as shown (Fig. 3) and rotate into position.
4. The crossbars on each end and in the center will bolt in with the supplied hardware. Insert the channel nut within the crossbar as shown (Fig. 4) and rotate 90 degrees. Place clamp washer on top of the channel nut and slide both to the outside of the tray so they sit under the slot. Attach with the hex head screw and washer.
5. Insert supplied rivets into all the holes connecting the crossbars, outer frame, and planks. Fasten using a rivet gun. Fasten outer frame together at joints with supplied screws and tighten crossbar fasteners.

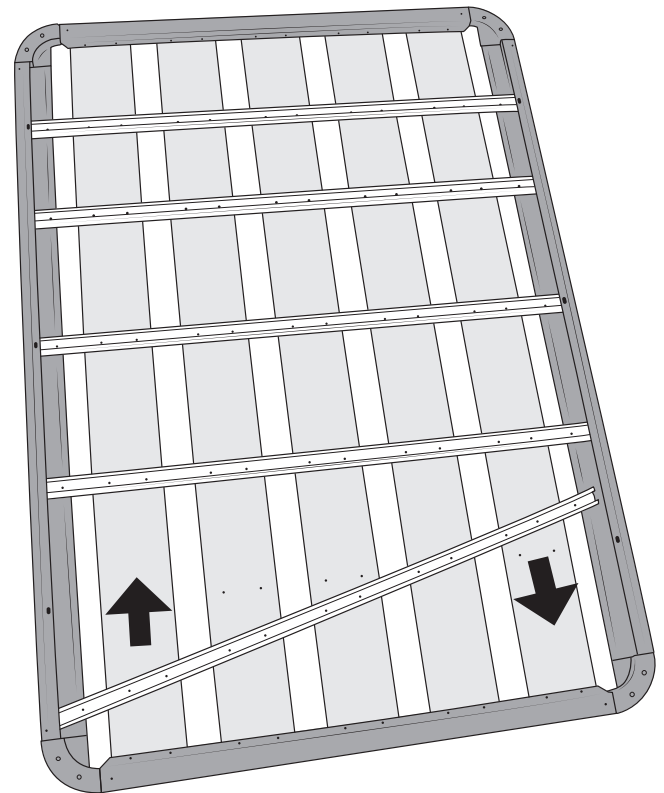

Figure 3

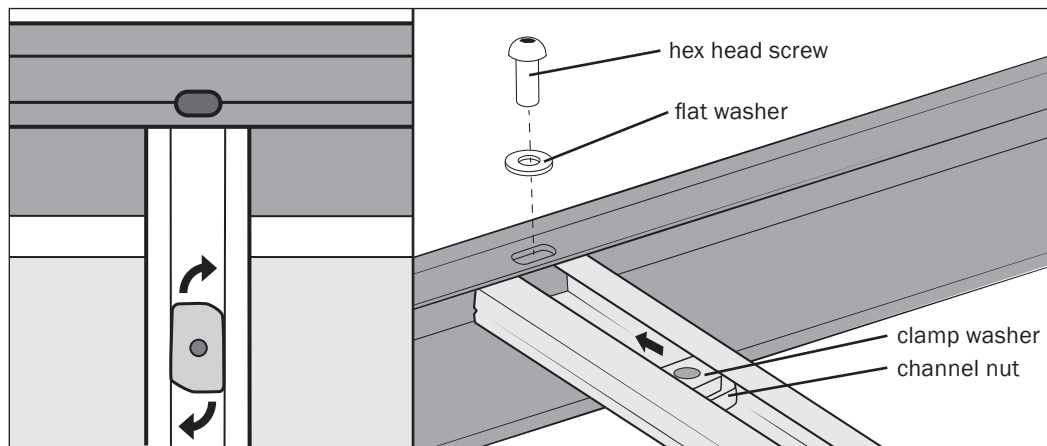

Figure 4



## PART II. INSTALLING ROLL-BAR BRACKETS

1. Remove hard top.
2. Remove sound bar.
3. Unzip roll bar padding and pull back to expose factory brackets (fig. 5.1 and 5.2). Remove bolts (shown in gray) and save. On the front, right side, detach the satellite radio antenna (if equipped) from its factory location and disconnect the wire connector. Be sure to save hardware.

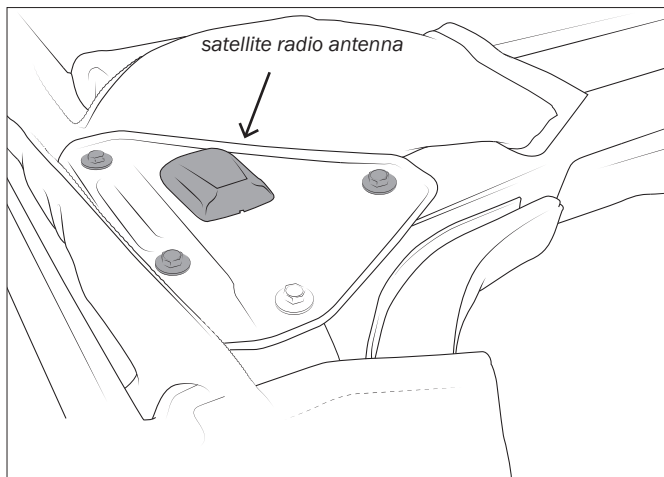

Figure 5.1 front

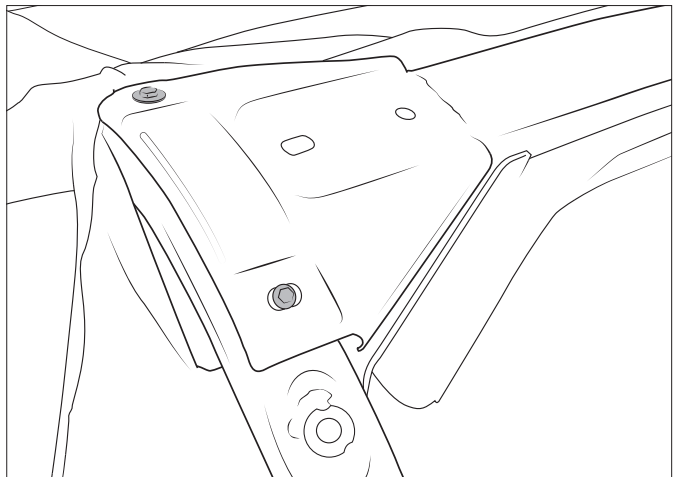

Figure 5.2 rear

4. Replace roll bar padding.
5. Position AEV brackets over roll bar padding to align with the corresponding holes in the roll cage from the bolts previously removed. Mark the hole's position on the padding and cut through the pad using a sharp awl or utility knife to allow access to them.
6. Place AEV brackets in position and secure loosely with the factory bolts removed previously (fig. 7.1 and 7.2). DO NOT tighten until all adjustments are made in the following steps.
7. Use the measurements in Figure 8 to adjust the bracket positions.

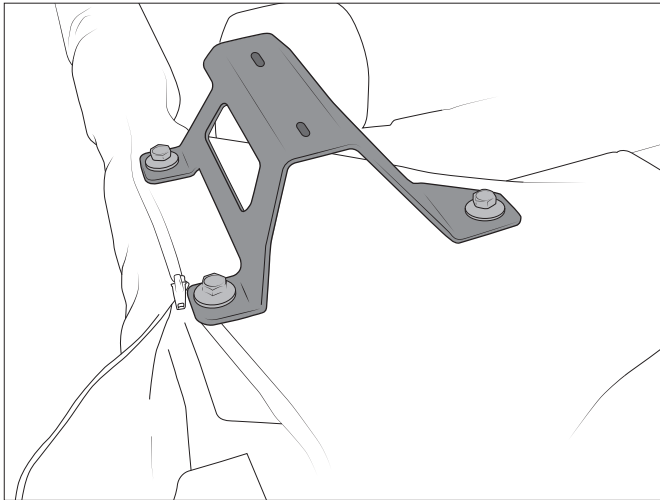

Figure 7.1 front

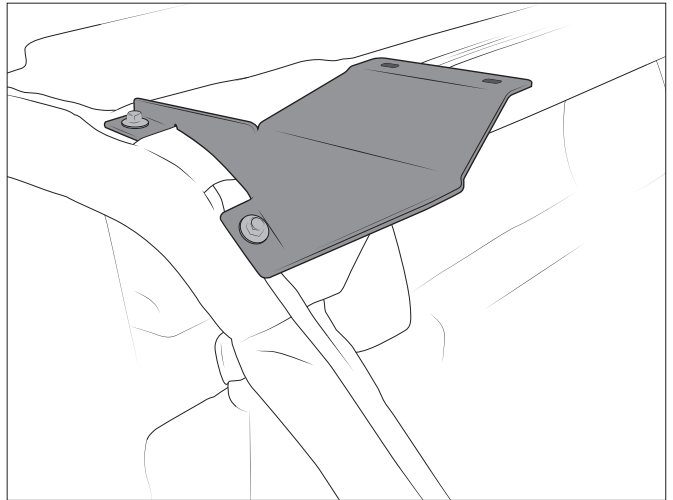

Figure 7.2 rear

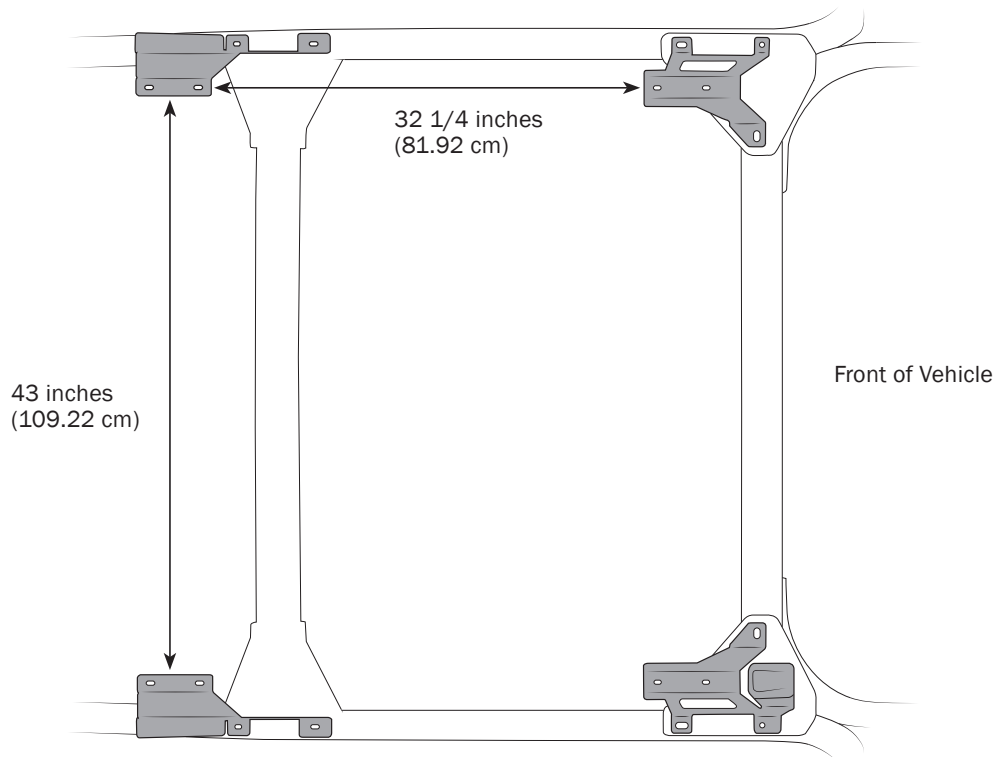
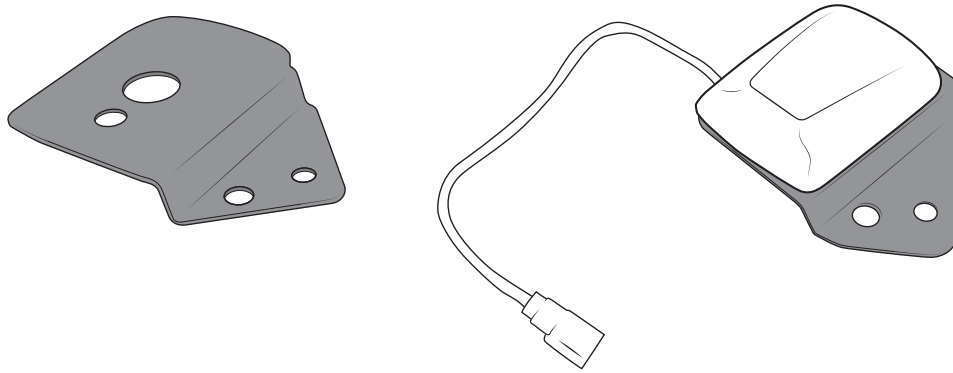

Figure 8



## PART III. RELOCATING SATELLITE ANTENNA

1. Attach satellite radio antenna, using its original hardware, to the AEV provided bracket.



2. Remove all trim from passenger (right) side B-pillar and floor
3. Locate antenna wiring, and remove from B-pillar at all attachment points.
4. Relocate wiring up the A-pillar (windshield frame)
5. Once proper routing has been established, excess wiring will need to be secured out of harm's way (fig. 9).



*Figure 9*



6. Fasten AEV bracket with satellite radio antenna to the windshield frame with the supplied bolt, nut, and washer through existing hole in the top of the A-pillar (fig. 10). **Pre-2013 JKs may or may not have this existing hole.** If your vehicle does not, you will need to drill a 5/16" hole. The remaining hole in the AEV bracket should line up with the existing hole in the A-pillar for the plastic fir-tree that secures the A-pillar trim. You can use this hole to locate the bracket on the A-pillar for drilling location.
7. Reinstall factory trim.

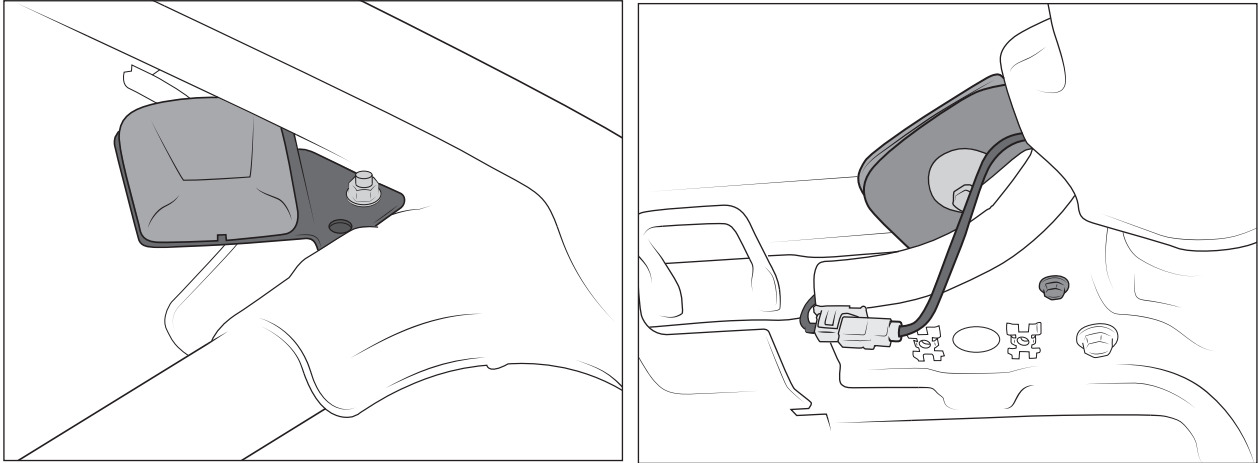

Figure 10





## PART IV. ATTACHING PLATFORM TO HARD TOP

### A. MARKING HARD TOP

1. Reinstall Hard top on Vehicle. Top should be completely secured with all factory fasteners to ensure proper position for drilling holes.
2. Press brackets up flush to the inside of the hard top and tighten all accessible fasteners.
3. Using the holes in the bracket, mark drilling positions on the inside of the hard top (8 holes).

### B. DRILLING HARD TOP

1. Remove hard top (you can now tighten any bracket fasteners that were not accessible before).
2. Drill pilot holes at marked locations with a small drill bit.
3. Using a 5/16" drill bit, drill final holes through hard top.

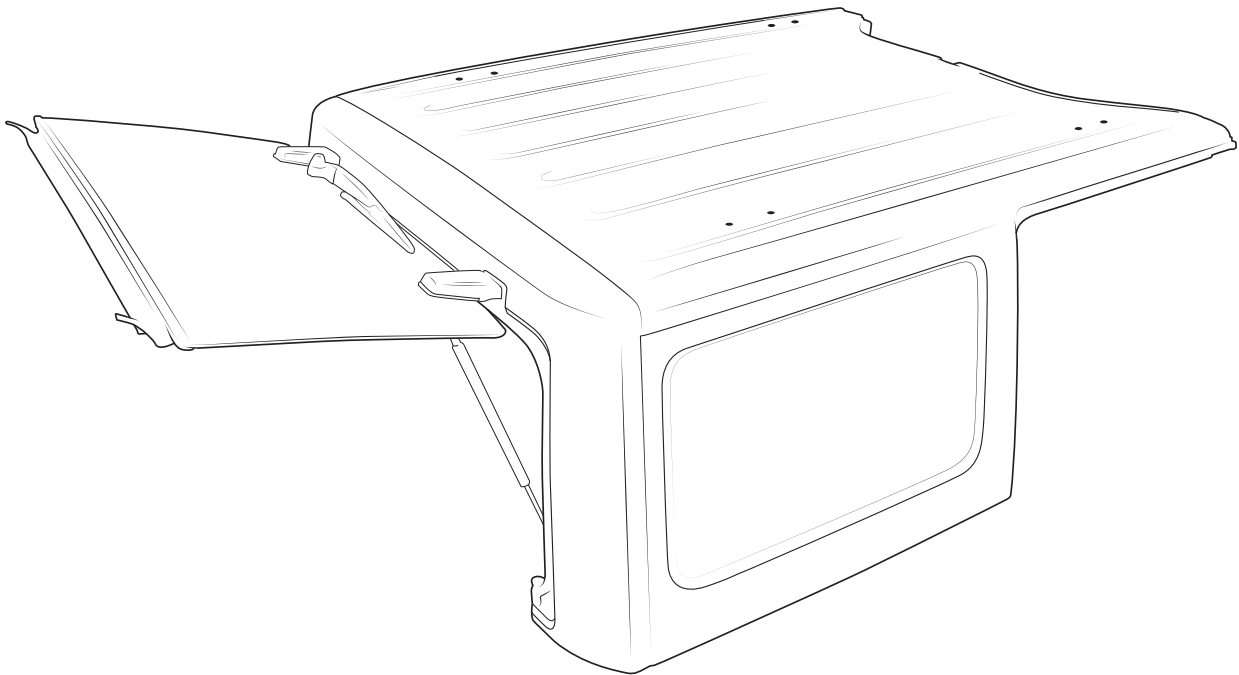



### C. ASSEMBLE STANTIONS

1. Pre-Assemble all four stantions as shown (fig. 11) leaving finger tight at this time. *NOTE: Additional hardware is included that is not required for this application.* Adhere the adhesive backed foam to the stantion foot, cut holes for the bolts to pass through, and trim tight to foot. Adhere the AEV Logo Decals to the stantions using the supplied alcohol swab to first clean the surface.
2. Reinstall Hard top on Vehicle. Top must be completely secured with all factory fasteners.
3. Position stantions on hard top inserting bolts through the newly drilled holes.
4. Working from the inside of the vehicle, fasten lock nuts onto stantion bolts and finger tighten

### D. ATTACH PLATFORM

1. Lift platform onto vehicle. Channel cutouts should be at the rear of the vehicle.
2. Insert stantion channel nuts into platform cross bars. Stantions connect to crossbars #1 and #4 if counting from the rear of the vehicle.
3. Center platform Left and Right over vehicle.
4. Tighten all fasteners, leaving the safety allen head screw for last.
5. Reinstall sound bar.

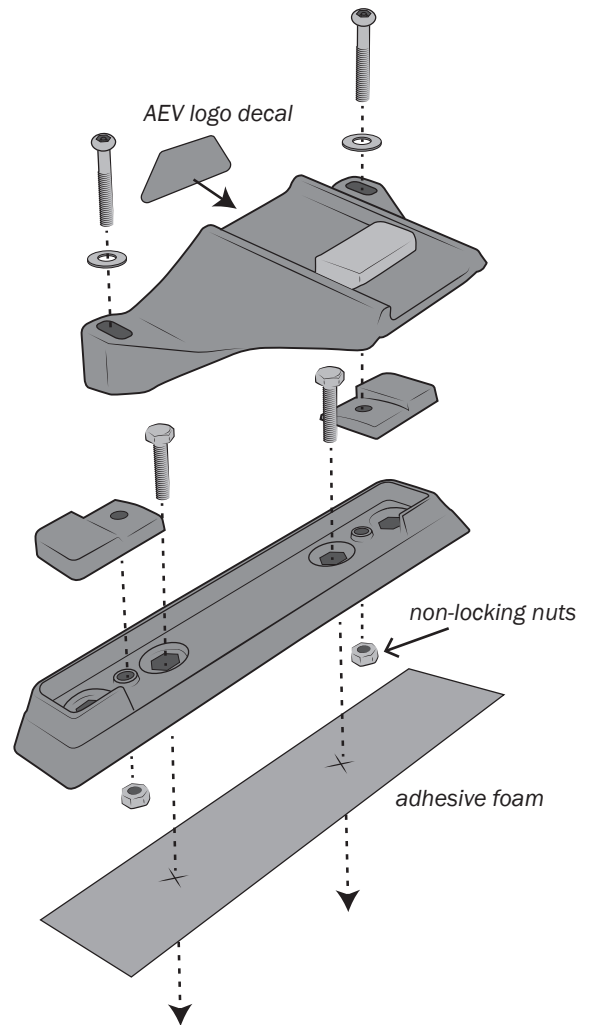

Figure 11



## **IMPORTANT INFORMATION:**

**Maximum carrying capacity: AEV can not recommend a weight carrying capacity. Refer to your Jeep owner's manual.**

It is essential that all bolt connections are checked after driving a short distance when you first install your AEV Roof Rack. Bolt connections should be checked again at regular intervals (probably once a week is enough, depending on road conditions, usage, loads, and distances travelled).

Make sure to fasten your load securely. Please ensure that all loads are evenly distributed and that the center of gravity is kept as low as possible.

### **USE ONLY NON-STRETCH FASTENING ROPES OR STRAPS.**

#### **SENSITIVITY TO CROSSWINDS BEHAVIOR IN CURVES AND BRAKING.**

The handling characteristics of the vehicle change when you transport a load on the roof. For safety reasons, we recommend you exercise extreme care when transporting wind resistant loads, special consideration must be taken into account when braking.

**Note for dealers and fitters.** It is your responsibility to ensure instructions are given to the end user or client.

## **COMMENTS OR QUESTIONS?**

American Expedition Vehicles

[www.aev-conversions.com](http://www.aev-conversions.com)

email: [tech@aev-conversions.com](mailto:tech@aev-conversions.com)

ph: 248.926.0256

**Be sure to visit our forum at: <http://forum.aev-conversions.com>**