

INSTALLATION INSTRUCTIONS

IN-DASH ELECTRIC TACHOMETER

2650-1138



QUESTIONS:

If after completely reading these instructions you have questions regarding the operation or installation of your instrument(s), please contact Auto Meter Technical Service at **815-899-0801**.

You may also email us at service@autometer.com.

Additional information can also be found at http://www.autometer.com/tech_fa.aspx

Calibration

IMPORTANT: This tachometer is factory calibrated to operate on 8 cylinder engines. For 4 or 6 cylinder engines, it is necessary to make the proper adjustments to adapt this tachometer to your cylinder range.

Locate the black plastic plug covering the switch access hole. The hole location is shown for 3¹/₈" and 3³/₈" sizes. The 5" size has a smaller access hole located in the upper left-hand portion of the case. Remove the plastic plug covering the access hole. Use a small screwdriver or an unwound paper clip to change the switch settings. Move each of the two switches to the proper cylinder selection according to the diagram illustrated on the right. Reinstall the plastic plug/cap into the access hole.

NOTE: This tachometer has an air core meter. With power off, it is normal for the pointer to leave zero. When power is applied, the pointer will move to the correct position.

Figure A.

- 4 CYL. - Switch One up, Switch Two down
- 6 CYL. - Switch One down, Switch Two up
- 8 CYL. - Both switches up

If you are unsure of your vehicle's pulse(s) per revolution or specific calibration requirements, contact Auto Meter's Service Dept. at (815) 899-0801, or go to www.autometer.com/hp/techtips for information.

Figure A

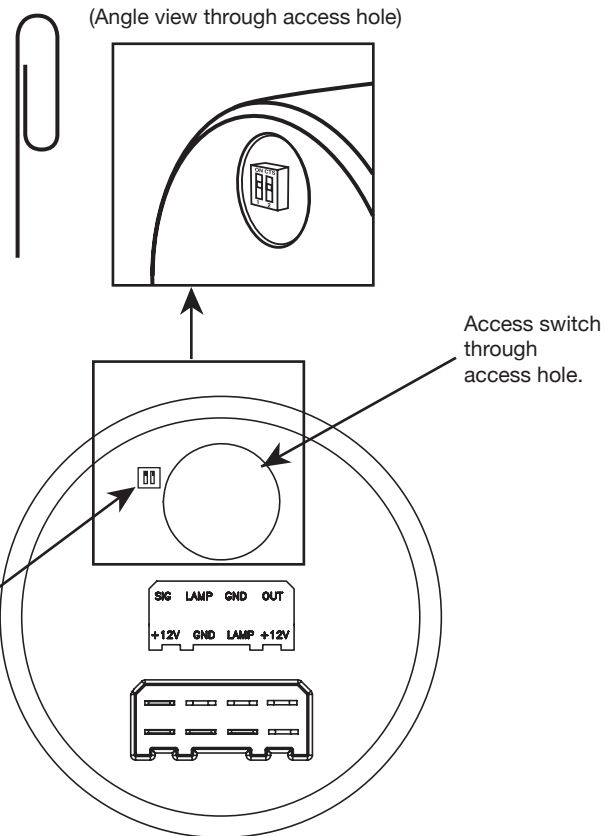
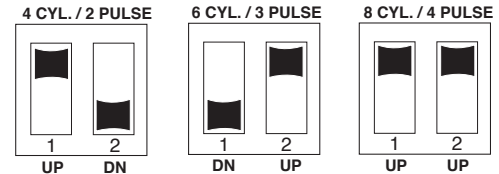

3³/₈" SIZE SHOWN

Lens Cleaning

To prevent scratching the lens when cleaning, use a mild, soapy solution to clean. Wipe lightly with a soft cloth.

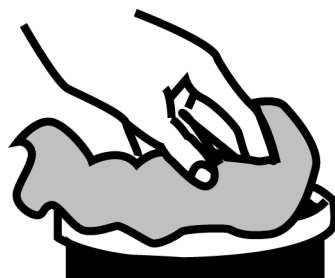

Note:

This tachometer operates on most early model ignitions, factory electronic and high performance electronic racing ignitions.

Mounting

1. Mount a 3 1/8" tachometer in a 3 5/32" dia. hole, a 3 3/8" tachometer in a 3 3/8" dia. hole and a 5" tachometer in a 4 5/8" dia. hole. Be careful not to cut the hole too large.
2. Cut a 3/8" dia. hole in the firewall for the tachometer wires. Place a rubber grommet in the hole and route the wires through the grommet to the engine compartment.
3. Connect the tachometer wires as shown in the wiring sections.
4. Secure the tachometer to the dashboard using the provided bracket and hardware.

3 1/8" Models

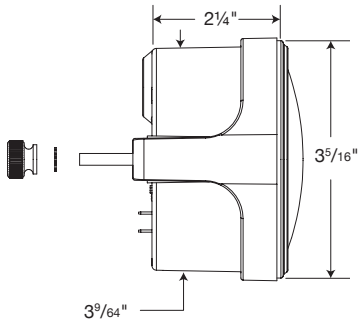

3 3/8" Models

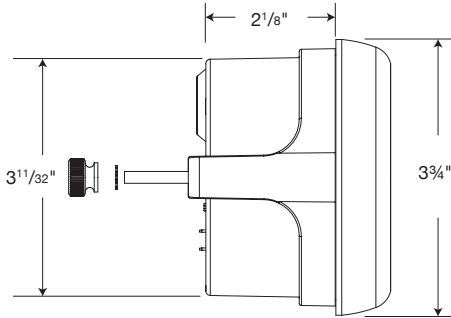

5" Models

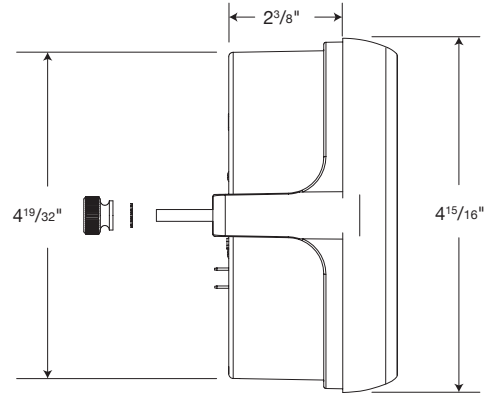

Wiring

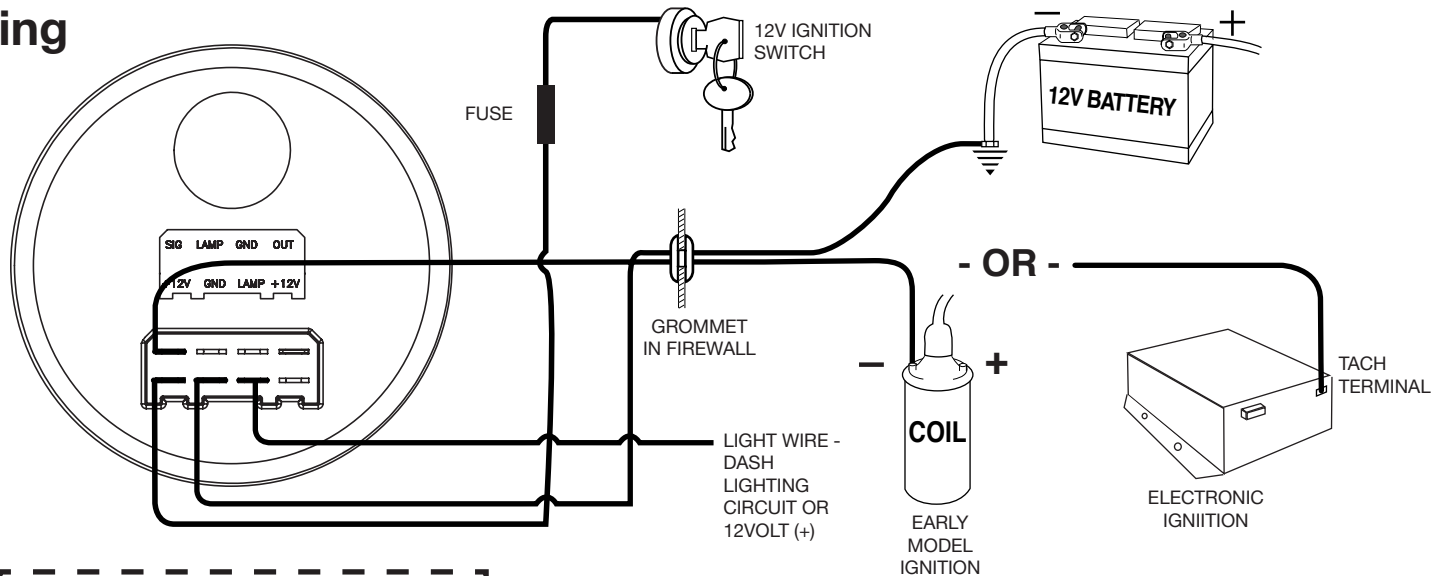

WARNING

Warranty will be void if connected to coil when using an aftermarket ignition box such as, but not limited to products from the following manufacturers: MSD, Crane, Jacobs, Mallory, Holley, Etc.. Prior to installation of your tachometer, check with the ignition box manufacturer for recommended tachometer signal location.

CAUTION!!!

As a safety precaution, the 12V terminal of this product should be fused before connecting it to the 12V ignition switch. We recommend using a 1 Amp, 3AG fast-acting type cartridge fuse (Littlefuse® #312 001 or an equivalent).

SERVICE

For service send your product to Auto Meter in a well packed shipping carton. Please include a note explaining what the problem is along with your phone number. Please specify when you need the product back. If you need it back immediately mark the outside of the box "RUSH REPAIR," and Auto Meter will service product within two days after receiving it. (\$10.00 charge will be added to the cost of "RUSH REPAIR.") If you are sending product back for warranty adjustment, you must include a copy (or original) of your sales receipt from the place of purchase.

12 MONTH LIMITED WARRANTY

Auto Meter Products, Inc. warrants to the consumer that this product will be free from defects in material and workmanship for a period of twelve (12) months from date of the original purchase. Products that fall within this 12 month warranty period will be repaired or replaced at Auto Meter's option to the consumer, when it is determined by Auto Meter Products, Inc. that the product failed due to defects in material or workmanship. This warranty is limited to the repair or replacement of parts in the Auto Meter instruments. In no event shall this warranty exceed the original purchase price of the Auto Meter instruments nor shall Auto Meter Products, Inc. be responsible for special, incidental or consequential damages or costs incurred due to the failure of this product. Warranty claims to Auto Meter must be transportation prepaid and accompanied with dated proof of purchase. This warranty applies only to the original purchaser of product and is non-transferable. All implied warranties shall be limited in duration to the said 12 month warranty period. Breaking the instrument seal, improper use or installation, accident, water damage, abuse, unauthorized repairs or alterations voids this warranty. Auto Meter Products, Inc. disclaims any liability for consequential damages due to breach of any written or implied warranty on all products manufactured by Auto Meter.

FOR SERVICE SEND TO: AUTO METER PRODUCTS, INC. 413 W. Elm St., Sycamore, IL 60178 (815) 899-0801

The "Super Bezel" is a registered trademark of Auto Meter Products, Inc. For Email: Service@autometer.com

© 2006 Auto Meter Products, Inc. 2650-1138 5/10/06