



# Installation Instructions PowerBoard NX

Automatic Retracting Running Board





Patent Pending

## Vehicle Application

- Jeep Wrangler Unlimited JK  
4 Door Only  
2007 and newer  
Part Number: 75622-15

*Note: Rubicon Rock Rails are not compatible with PowerBoards and will need to be removed.*

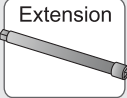
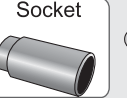
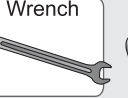
[www.bestop.com](http://www.bestop.com) - We're here to help! Visit our web site and click on "Ask a Question". Click here for more [Truck Accessories by Bestop](#).

INSTALLATION TIME		SKILL LEVEL	
			
3 Hours		3 - Moderately Difficult	
TOOLS			
 Ratchet	 Extension	 Socket 13 mm	 Wrench 10 mm
			 Allen Wrench 4 mm
 Electrical Tape	 Safety Glasses		



**! WARNING** The manufacturer strongly recommends that this product be professionally installed.

**! WARNING** Failure to carefully follow the electrical installation steps could result in severe electrical shock which could harm the installer and/or damage the vehicle.

**! WARNING** Do not rely in any way on the components of this product to protect against injury or death in the event of an accident. Never operate the vehicle in excess of manufacturer's specifications.

### WEAR SEAT BELTS AT ALL TIMES

Read and follow, precisely, all installation instructions provided when installing product. Failure to do so may result in a poor fit and could place occupants of the vehicle in a potentially dangerous situation.

# PowerBoard NX – Installation Instructions

## Parts List and Hardware Identification

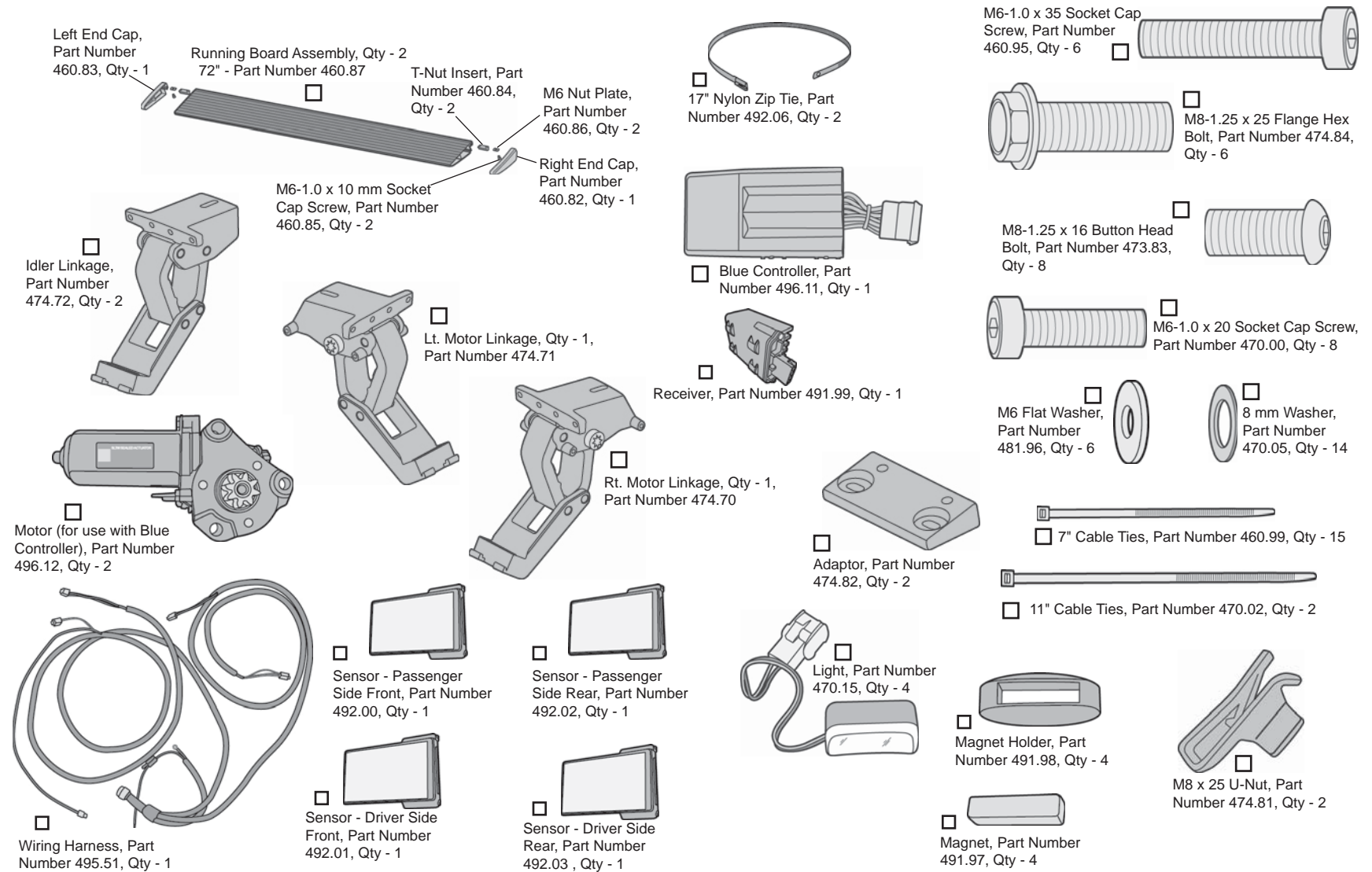

# PowerBoard NX – Installation Instructions

## RF System Overview

The PowerBoards are activated by Sensors that are to be mounted inside the door openings for each door. The Sensors are off when a magnet is next to the Sensor end that has the two screws. The Sensor triggers the PowerBoards to deploy when the magnet is moved about 3 inches away from the Sensor. The magnet can work in either of the locations shown to signal the PowerBoards to retract.

Be sure to mount the Sensors in a location that will allow removal of the screws for battery replacement. See Battery Replacement at the end of the instructions.

See Steps 14 – 18 for detailed instructions.

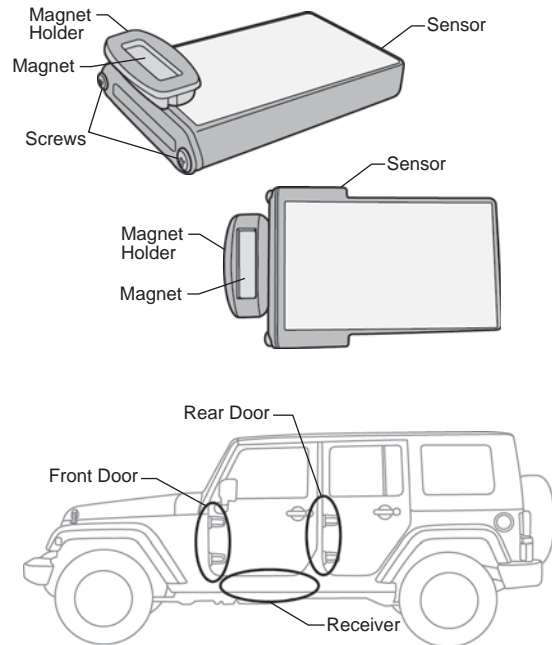

## 1 System Initialization

- Remove fuse from wire harness and connect the red lead to the battery positive and the black lead to negative.
- Layout the harness so the long leg crosses the engine compartment towards the drivers side and the short leg is on the passenger side.
- Attach a motor to each motor link with 3 M6-1.0 x 35mm Socket Cap Screws.
- Plug the Controller, Receiver, Motors and Lights into the harness.
- Plug the fuse back into the harness. After a one second delay the linkages will retract as shown.
- Lay out all four sensors as they would be installed on the vehicle with the drivers side to your left and the passengers side to your right. Place a magnet next to each sensor as shown in the overview above.
- Move the magnet more than 4 inches away from the driver front sensor. All four lights will come on and the drivers side linkage will deploy.
- Move the magnet back to the sensor and after a three second delay the lights will turn off and the linkage will retract.
- Repeat with the remaining sensors and the lights and corresponding linkage will operate in the same manner.
- Remove the motors to continue with the installation.

If the system does not operate as stated above see the Troubleshooting and Battery Replacement sections at the end of the instructions or go to our web site at <http://www.bestop.com/support>.

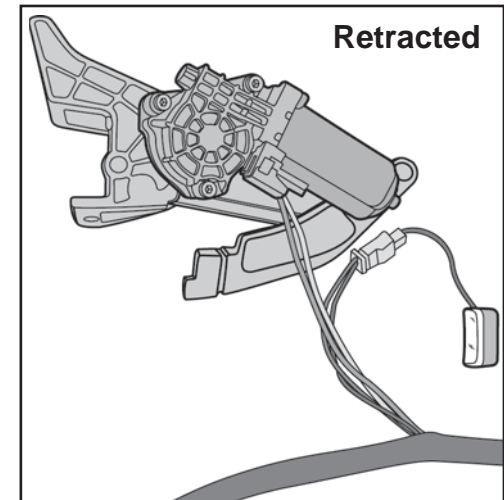
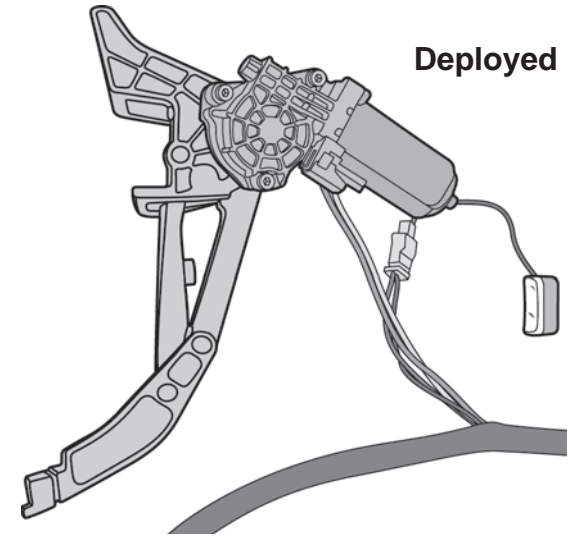

## PowerBoard NX – Installation Instructions

### 2 Install Adaptor – Passenger Side

Locate the rear linkage position in front of the rear body mount. Install the Adaptor with a Flange Hex Bolt. Tighten the bolts.

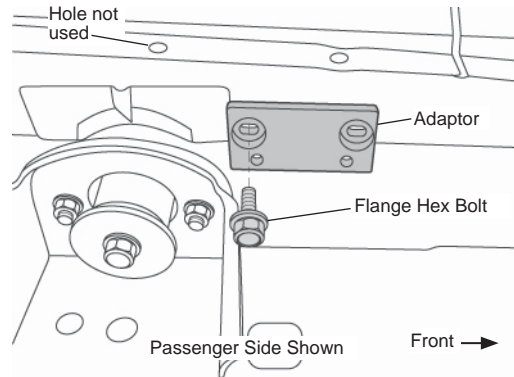

### 3 Install Rear Motor Linkage – Passenger Side

Position the passenger side linkage against the pinch weld with the motor shaft pointing forward. Mount a Motor Linkage with a Button Head Bolt and 8mm Washer at the pinch weld hole and a Flange Hex Bolt in the inboard hole. Mark the pinch weld at the second hole location and remove the linkage. Drill a 1/8" pilot hole at the marked location then drill a 3/8" hole. Reinstall the link using an additional Button Head Bolt and 8mm washer in the drilled hole.

**Finger tighten fasteners at this time.**

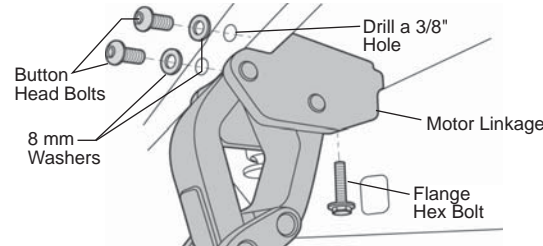

### 4 Install U-Nut – Passenger Side Front

Install an M8 x 25 U-Nut in the hole next to the Body mount behind the front tire.

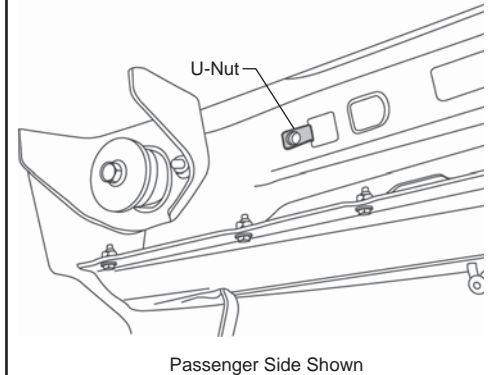

### 5 Install Front Idler Linkage – Passenger Side

Use two (2) Button Head Bolts and 8 mm Washers and a Flange Hex Bolt to mount the Idler Linkage to the vehicle. Tighten the fasteners. Shim the linkage inboard with 1 to 3 washers between the linkage and the pinch weld on the rear hole so it operates smoothly when the board is attached (2 are usually sufficient).

**Do not tighten the bolts at this time.**

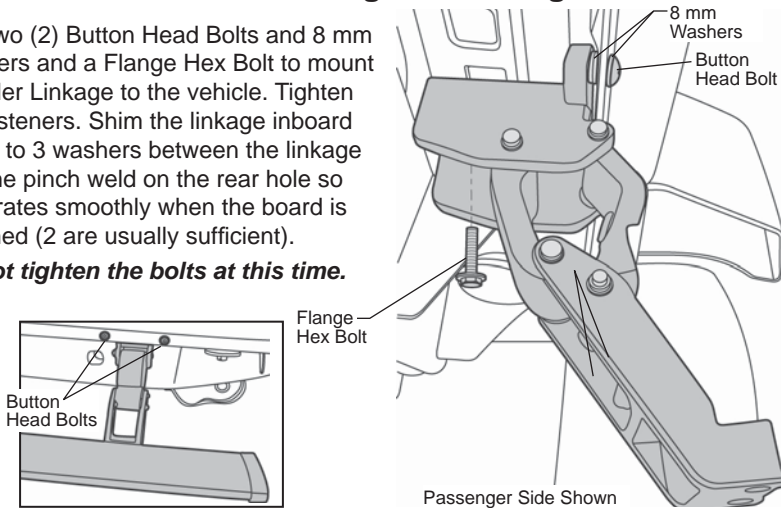

### 6 Install Driver's Side Linkages

Repeat steps 1 – 4 on the driver's side of the vehicle.

**! WARNING** Remove the fuse from the Wiring Harness.

### 7 Remove Fuse from Wiring Harness

Remove the fuse from the Wiring Harness. Failure to do so could result in severe electrical shock which could harm the installer and/or damage the vehicle.

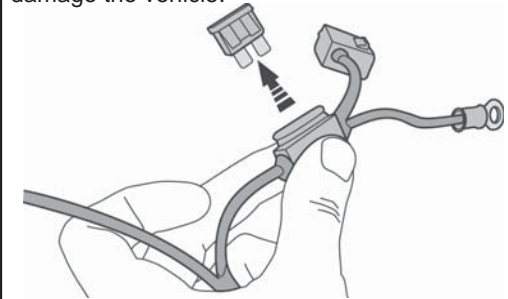



# PowerBoard NX – Installation Instructions

## 8 Install Controller and Wiring Harness

Secure the Controller to the passenger side firewall with 11" Cable Ties. Connect the red lead to the positive battery terminal and the black lead to the negative terminal.

Connect the Wiring Harness to the Controller.

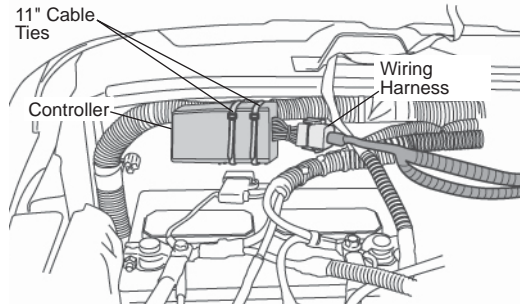

## 9 Route Wiring Harness

Route the long leg of the Wire Harness across the firewall to the driver's side and under the vehicle outside of the frame rail.

Route the short leg down the firewall and outside the frame rail on the passenger side.

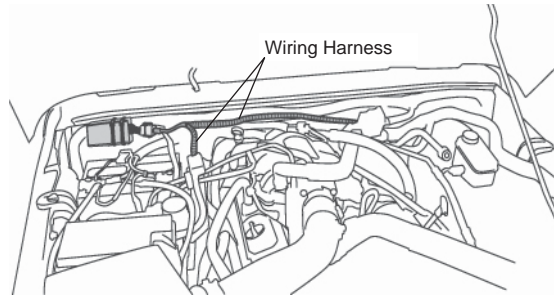

## 10 Install Lights

Clean the outboard surface of the of the Linkage below the bottom mounting bolt. Peel the adhesive liner off the back of the Light and firmly press it 1/8" below the mounting bolt. Plug the light into the connector with the black and orange wires in the wire harness. Repeat with the other three lights. Secure loose wires with Cable Ties.

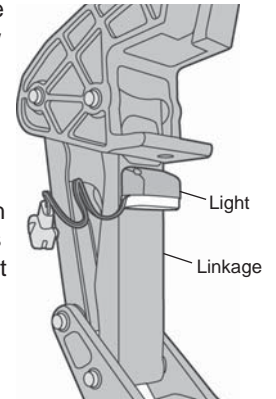

## 11 Install Receiver

Route the small diameter wire harness along the side of the frame. Find a location that is protected but is not surrounded by dense metal. Plug in the Receiver and insert 17" Nylon Zip Ties through the loops on the Receiver. Mount the Receiver with the stand off ribs against the vehicle.

**NOTE** Due to vehicle variations, installation may differ from that shown.

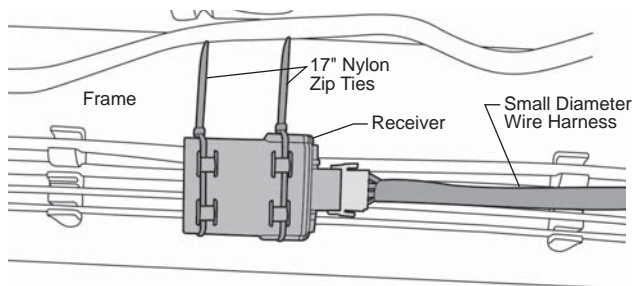

## 12 Install Running Boards

Mount the Steps to the linkages. Slide the mounting T-Nut into position. Install M6-1.0 x 20mm Socket Head Bolts to secure the boards. Use a 5mm Allen Wrench to tighten the bolts.

Make sure the board moves up and down freely by hand. If it binds, loosen the linkage to body attachment bolts and adjust the linkage position until the boards move freely. **Do not tighten the bolts at this time.**

**NOTE** Tightening the fasteners before cycling the step several times may create a bind, causing a squeaking sound and preventing the boards from retracting completely and evenly.

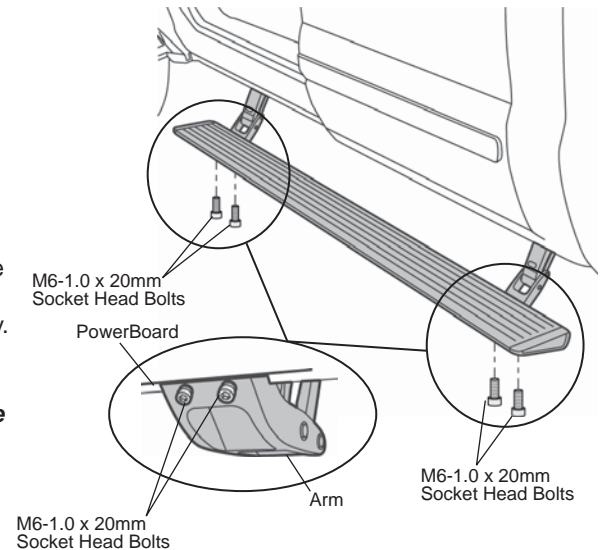

## PowerBoard NX – Installation Instructions

### 13 Install Motor

Slide Motor assembly onto drive shaft and mounting bosses of Motor Linkage assembly. Use three (3) M6-1.0 x 35mm Socket Cap Screws and M6 Flat Washers to secure Motor. Plug female connector into Motor. Wrap any exposed wires from the motor with electrical tape. Torque the screws to 5-7 ft. lbs. (6.78-9.49 Nm or 60-84 in. lbs.)

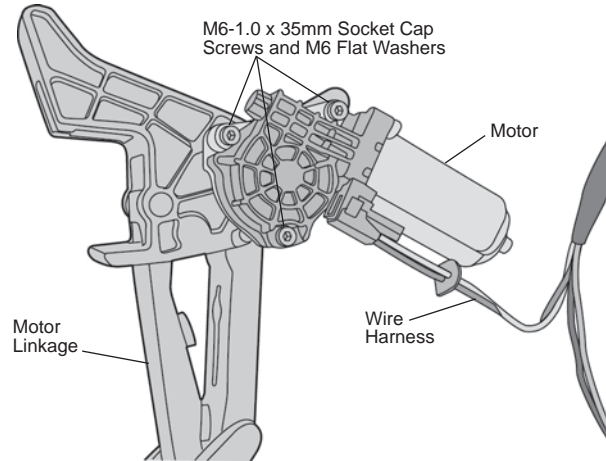

### 14 Install Magnet and Magnet Holder

Open the front door and clean the area where the Magnet and Sensor will be installed with a 50/50 solution of water and alcohol. Stick a Magnet on the front face of the top hinge. Position it so it is flush with the bottom of the hinge flange and is 1" away from the hinge notch in the door. Peel the liner off of a Magnet Holder and press it firmly around the Magnet.

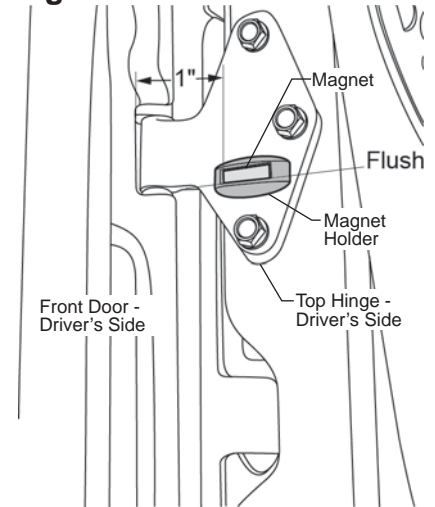

### 15 Install Driver's Side Front Sensor

Peel the liner off of the Driver's Front Sensor. Orient it so the end of the sensor with the two screws faces up. Position it on the front face of the door so the top of the sensor is flush with the bottom of the hinge notch and so the screw boss is touching the outboard door flange. Press firmly on the sensor to stick it to the door.

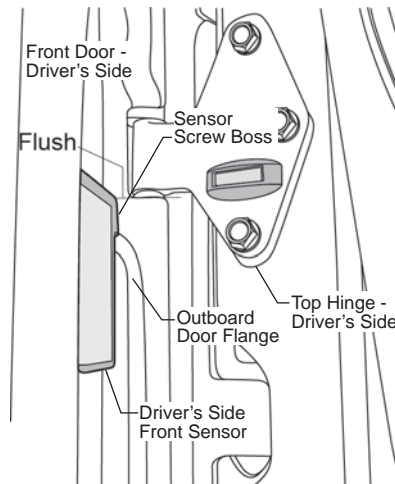

### 16 Install Magnet and Magnet Holder

Open the rear door and clean the area where the Magnet and Sensor will be installed with a 50/50 solution of water and alcohol. Stick a Magnet on the front face of the top hinge. Position it so it is flush with the bottom of the hinge flange and is 1" away from the hinge notch in the door. Peel the liner off of a Magnet Holder and press it firmly around the Magnet.

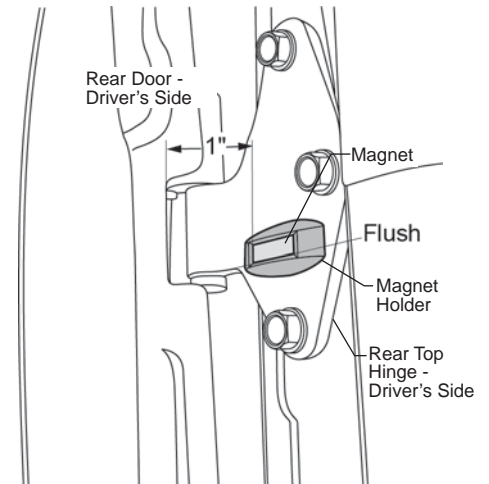

## PowerBoard NX – Installation Instructions

### 17 Install Driver's Side Rear Sensor

Peel the liner off of the Driver's Rear Sensor. Orient it so the end of the sensor with the two screws faces up. Position it on the front face of the door so the top of the sensor is flush with the bottom of the hinge notch and so the screw boss is touching the outboard door flange. Press firmly on the sensor to stick it to the door.

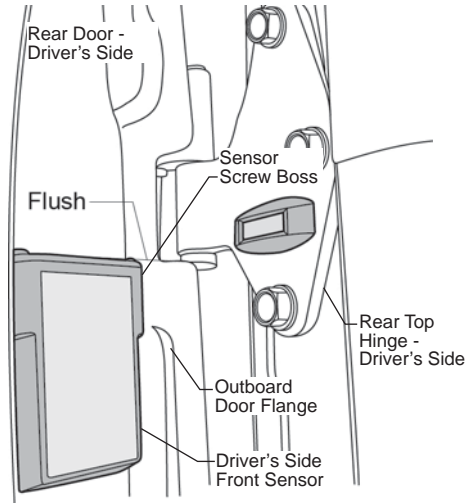

### 18 Install Passenger Side Sensors and Magnets

Repeat Steps 14 through 19 on the passenger side of the vehicle.

### 19 Reinstall Fuse

Reinstall the fuse in the harness.

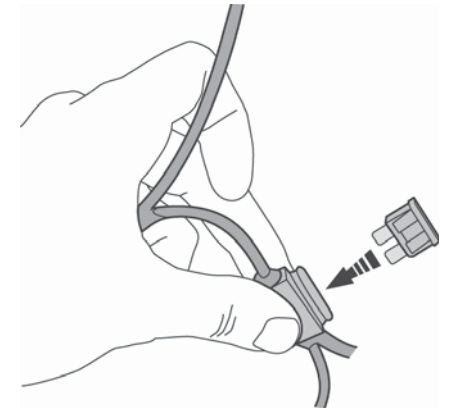

### 20 Test Doors and PowerBoards

Open and shut each door to make sure the PowerBoards deploy and retract. There is a slight delay in the board deployment so make sure they are fully down before stepping on them. There is also a 3-4 second delay in board retraction after the door is shut. This gives you time to open another door without cycling the board again. **Cycle the boards several times and then fully tighten all of the fasteners.**



Never force the board up or down. Use the motors to cycle the board.

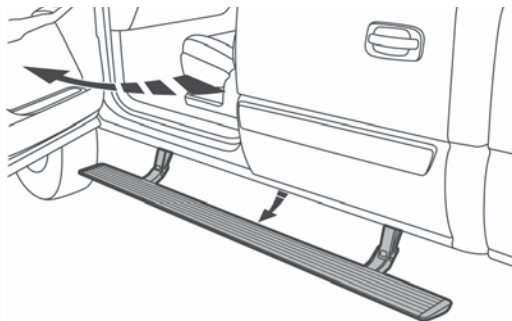

# PowerBoard NX – Installation Instructions

## PowerBoard NX Troubleshooting

### Issue:

- Possible cause

### Boards do not operate:

- Bad ground
- Bad battery connection
- Fuse burned
- Magnet is too far away from Sensor
- Bad receiver connection
- Sensor battery low

### Board creaks or squeaks during operation:

- Gear shaft wedge bolt is loose
- Loosen mounting bracket and board attachment screws. Adjust linkages so they are parallel to each other and the noise is gone. Tighten all fasteners.

### Intermittent operation:

- Bad battery connection
- Bad ground
- Magnet is too far away from Sensor
- Bad receiver connection
- Sensor battery low

### Boards operate randomly:

- Wire connections not secure
- Magnet is too far away from Sensor
- Bad receiver connection
- Sensor battery low

### Board stays down all the time and can be moved by hand:

- Gear shaft wedge screw is missing or loose

### Board shakes and or shutters during operation:

- Bad ground
- Wire connections not secure
- Bad battery connection
- Links misaligned

### Delay in board operation or boards operate after doors are shut:

- Magnet is too far away from Sensor
- Sensor battery low

### Board hits body

- Install supplied adhesive bumper per the installation instructions.

### Board does not fully retract or deploy

- The board is designed to stop travel when the system senses a load. Misalignment can cause the board to stop early. Remove the motor and adjust the linkage alignment until the board moves up and down freely without resistance by hand.

### Board retracts when doors are left open for a long period of time.

- This is normal to save sensor battery life.

## PowerBoard NX Service Tips

### Adjusting Linkage alignment:

The board is designed to stop travel when the system senses a load. Misalignment can cause the board to stop early.

To adjust, remove running board and motor. Loosen mounting brackets. Adjust linkages parallel to each other. Shift the running board on linkages 1/8" in either direction and carefully set board on linkages. Start only a few threads of the allen head bolts – do not tighten yet. Lift running board to retracted position. Tighten allen head bolts that attach running board to linkage. Last, tighten linkages to body. Cycle running board by hand without motor and confirm zero resistance. Install motor and test.

## Linkage Component Identification

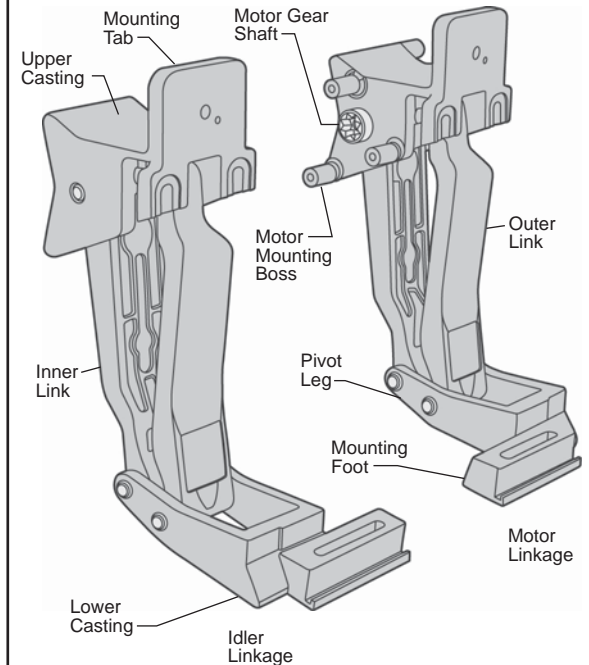



## PowerBoard NX – Installation Instructions

### Battery Replacement

Each sensor is powered by a CR2450 3 volt battery that may periodically need to be replaced.

1. Remove the Power Board fuse that is next to the car battery.
2. Remove the two screws and the cover plate on the sensor. Slide out the circuit board and note the orientation of the board. Replace the battery and slide the board back into the housing with its original orientation. Leave the vehicle door or doors open.
3. Reinstall the PowerBoard fuse and wait 30 seconds. The sensor is reprogramming its address during this time.
4. Shut the door(s). Open and close the doors(s) to check for normal operation.

If opening a door fails to operate the PowerBoard, open the appropriate door and remove the PowerBoard fuse. Wait 30 seconds and the reprogramming will repeat. Reinstall the fuse and check for normal operation.

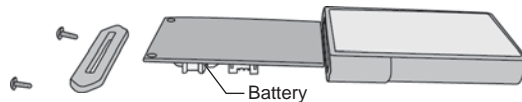

This device complies with Industry Canada licence-exempt RSS standard(s). Operation is subject to the following two conditions: (1) this device may not cause interference, and (2) this device must accept any interference, including interference that may cause undesired operation of the device.

Le présent appareil est conforme aux CNR d'Industrie Canada applicables aux appareils radio exempts de licence. L'exploitation est autorisée aux deux conditions suivantes: (1) l'appareil ne doit pas produire de brouillage, et (2) l'utilisateur de l'appareil doit accepter tout brouillage radioélectrique subi, même si le brouillage est susceptible d'en compromettre le fonctionnement.

This device complies with Part 15 of the FCC Rules. Operation is subject to the following two conditions:

- (1) This device may not cause harmful interference
- and
- (2) This device must accept any interference received, including interference that may cause undesired operation.

The user is cautioned that changes or modifications not expressly approved by the party responsible for compliance could void the user's authority to operate this equipment.

## PowerBoard NX – Installation Instructions

---

### LIMITED WARRANTY

We warrant our product to be free from defects in material and workmanship, for the terms specified below, provided there has been normal use and proper maintenance. This warranty applies to the original purchaser only. All remedies under this warranty are limited to the repair or replacement of any item or items found by the factory to be defective within the time period specified. If you have a warranty claim, first you must call our factory at the number below for instructions. You must retain proof of purchase and submit a copy with any items returned for warranty work. Upon completion of warranty work, if any, we will return the repaired or replaced item or items to you freight prepaid. Damage to our products caused by accidents, fire, vandalism, negligence, misinstallation, misuse, Acts of God, or by defective parts not manufactured by us, is not covered under this warranty.

THE WARRANTY TIME PERIOD IS AS FOLLOWS FOR ALL PowerBoards MANUFACTURED BY OUR COMPANY: THREE YEARS / 36,000 MILES FROM DATE OF PURCHASE.

ANY IMPLIED WARRANTIES OF MERCHANTABILITY AND/OR FITNESS FOR A PARTICULAR PURPOSE CREATED HEREBY ARE LIMITED IN DURATION TO THE SAME DURATION AND SCOPE AS THE EXPRESS WRITTEN WARRANTY. OUR COMPANY SHALL NOT BE LIABLE FOR ANY INCIDENTAL OR CONSEQUENTIAL DAMAGE.

Some states do not allow limitations on how long an implied warranty lasts, or the exclusion or limitation of incidental or consequential damages, so the above limitations or exclusions may not apply to you. This warranty gives you specific legal rights, and you may also have other rights which vary from state to state.



For further information or request for warranty work, please contact:

Bestop Inc. Customer Service  
Toll-Free: (800)845-3567  
Main: (303)465-1755  
E-mail: [csbestop@Bestop.com](mailto:csbestop@Bestop.com)  
Website: [www.Bestop.com](http://www.Bestop.com)