



Protecting Your Adventure Lifestyle

Warrior Products, Inc.
 16850 SW Upper Boones Ferry Rd
 Ste. A
 Durham, OR 97224
 Phone (888) 220-6861
 Fax (503) 692-0364
 sales@warriorproducts.com

885 JK WRANGLER UNLIMITED RENEGADE RACK INSTALLATION SHEET

Important Notes: Some brands of windshield light brackets and snorkels may not be compatible with the 885 Renegade Roof Rack System. Body lifts are also not compatible with this rack system. Please keep this in mind when deciding upon any upgrades or accessories that may conflict with the racks' mounting locations. It is recommended to have an additional person to assist you during some steps of this installation process. Some customers may be sensitive to the wind noise generated by a roof rack. Mounting of the optional accessory '888 Renegade Air Dam' can drastically reduce the amount of wind noise experienced.

Kit Contents:

Item	Qty	Item	Qty	Item	Qty
A-pillar mount - D	1	Rear mount bracket - D	1	7/16" Flat washer	4
A-pillar mount - P	1	Rear mount bracket - P	1	8mm x 25mm Screw	6
Front leg - D	1	Pinch seam clamp - D	1	3/8" x 1" Carriage bolt	8
Front leg - P	1	Pinch seam clamp - P	1	3/8" Lock washer	8
Rear leg - D	1	7/16" x 3" SS Button head bolt	4	3/8" Regular nut	10
Rear leg - P	1	7/16" Lock washer	4	5/16" SS Flat head screw	8
Main basket	1	7/16" Regular nut	4	5/16" Lock washer	8
Front basket section	1	7/16" x 2.5" Bolt	4	5/16" Regular nut	8
Rear basket section	1	7/16" Lock washer	4	Urethane bump stop	2
		7/16" Bushing sleeve	4	Urethane bushing	8

Phase 1: Mounting Brackets Installation

- The side of the A-pillar has 4 Torx bolts per side. Remove the top 3 and install the A-pillar mount with the 8mm flat head Allen screws. Repeat for the opposite side. **Fig. 1**
Note: If you are at all concerned about possibly damaging the paint under the brackets, utilize a piece of bicycle inner tube and trace around the mounting surface of the bracket. Cut it out for a makeshift gasket.



- The rear mount brackets are a little more involved. In most cases, temporary removal of the rear bumper and related bracketry is required.

- Take the Rear Mount Bracket labeled 'P' (passenger side) and match it up with the Pinch Seam Clamp labeled 'P'. Loosely thread the 7/16" x 2.5" bolts along with a 7/16" lock washer and a 7/16" flat washer up through the bottom of the Rear Mount Bracket and into the Pinch Seam Clamp. **Fig. 2**

- Hold the assembled passenger side bracket against the side of the frame where the factory bumper mount holes are located. The pinch seam of the Jeep tub should set between the bracket and the clamp. Utilizing

a factory bumper side bolt, loosely thread one through the bottom hole of the bracket into the frame. This is to hold the brackets into place while you slide the rear bumper back on. Repeat steps for the driver side.

Fig. 3



5. If you are reinstalling the factory plastic bumper, you will need to mount the bumper brackets on the outside of the Rear Mount Brackets. If you are fitting an aftermarket bumper, you most likely will be 'sandwiching' the bumper mount brackets *between* the frame and the Rear Mount Brackets. This is why the lower bolt is loosely threaded into the frame as it's easier to pull that bolt quickly while fitting the bumper and reinserting it after the bumper has been fully seated. It can be a bit of a juggle installing the rear bumper while keeping the Rear Mount Brackets in their correct positions, so an extra set of hands is very helpful. Once you have the rear bumper set all the way on and the mounting holes lined up, thread the remaining factory bolts through the Rear Mount Brackets and into the frame and tighten them. Now tighten the Pinch Seam Clamp bolts to complete this step in the process. **Fig. 4 & Fig. 5**

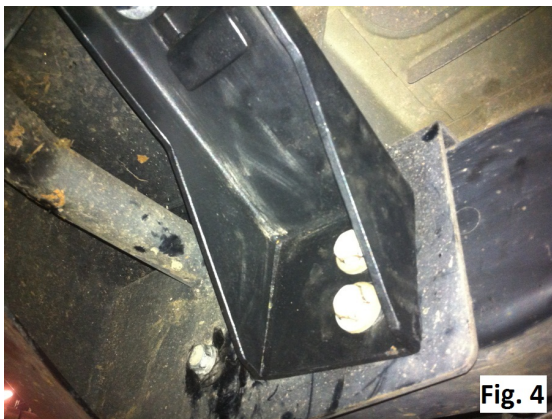

Note: For additional strength of the rear mounts, provisions have been made to add carriage bolts through the u-shaped part of the bracket and through the top surface of the bumper endcaps. Spacers may need to be fabricated to close the gap between the two surfaces. (Hardware not provided)



Protecting Your Adventure Lifestyle

Warrior Products, Inc.
16850 SW Upper Boones Ferry Rd
Ste. A
Durham, OR 97224
Phone (888) 220-6861
Fax (503) 692-0364
sales@warriorproducts.com

Phase 2: Rack Legs Installation

1. Begin by assembling the urethane bushings and $\frac{1}{2}$ " metal sleeves into the pivoting tubes at the bottom of each leg. A mallet and some WD40 will help facilitate the process.
2. Mount the front legs to their respective 'D' and 'P' sides with the $\frac{1}{2}$ " x 3.0" SS button head bolts. A $\frac{1}{2}$ " lock washer followed by a $\frac{1}{2}$ " regular nut completes this step. The front legs can be pivoted forward till they rest upon the A-pillar mounts' built in stops.
3. **OPTIONAL STEP:** There are urethane bump stops included in the kit that you may choose to install that will stiffen the rack system against the Jeeps' tub. The bump stops will rest directly against the tub and may rub against the paint, so if this is a concern to you take the necessary steps to prevent this. Begin by taking the urethane bump stops and threading a $\frac{3}{8}$ " regular nut all the way onto the threads so the nut stops against the urethane. Each rear leg has gusset with a $\frac{3}{8}$ " threaded mount. Thread the urethane bump stop into this mount till it stops against the $\frac{3}{8}$ " nut welded to the leg gusset.
4. Finally, mount the rear legs into their respective 'D' and 'P' sides with the $\frac{1}{2}$ " x 3.0" SS button head bolts, lock washers and nuts. The top of the legs can lightly rest against the Jeeps' top or you can use a couple blocks of wood to space it away.



Phase 3: Main Basket Install Steps

1. With the aid of an assistant, lift the main basket into place onto the roof of the Jeep. Place a small block of wood (short pieces of 2x4 are perfect) under each corner of the basket to position the mounting plates in line with the mounting plates of the legs.
2. Working at one corner at a time, take the (8) $\frac{5}{16}$ " x 1" flat head screws and place them through the countersunk holes in each mounting plate at the top of the legs. Next, place the (8) $\frac{3}{8}$ " x 1" carriage bolts through the main baskets' square holes in the mounting plates so the threads go through the corresponding holes in the legs mounting plates. Place a $\frac{3}{8}$ " lock washer and $\frac{3}{8}$ " regular nut on each carriage bolt and hand tighten them. Don't crank them tight just yet, as you want a little movement while you're still placing the rest of the componentry together. **Fig. 6**
3. With the mounting plates all lightly bolted together, remove the wood blocks.
4. Take the rear basket section and fit the mounting plate ends over the threads on the $\frac{5}{16}$ " x 1" flat head screws that are now sandwiched between the mounting plates of the basket and the rear legs. Thread on the $\frac{5}{16}$ " lock washers and regular nuts and tighten. There are access holes through the basket end plates to utilize an Allen wrench if needed.

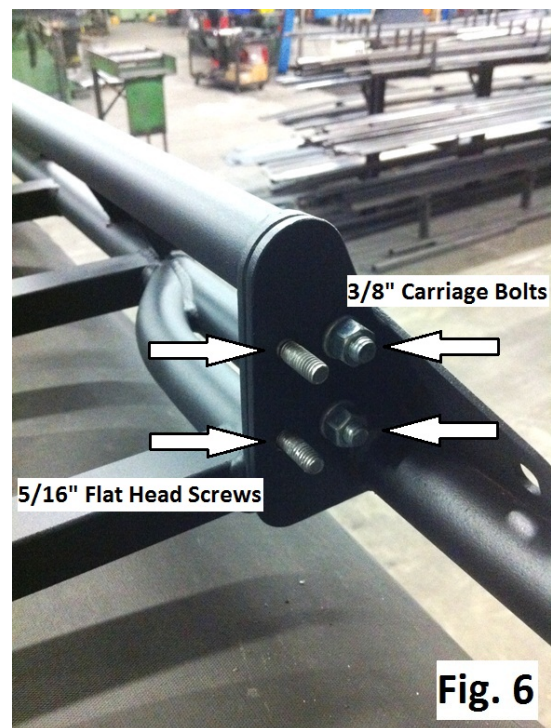

QUALITY



INTEGRITY



INNOVATION



SERVICE



Protecting Your Adventure Lifestyle

Warrior Products, Inc.
16850 SW Upper Boones Ferry Rd
Ste. A
Durham, OR 97224
Phone (888) 220-6861
Fax (503) 692-0364
sales@warriorproducts.com

5. Repeat for the front basket section.
6. Once the bolts for the front and rear basket sections have been tightened, now tighten the 3/8" carriage bolts at all four corners.
7. If the rack requires side-to-side positioning or stiffening, this can be accomplished by adjusting the rear legs bump stops against the Jeep tub and locking into place with the 3/8" nut on the bump stop stud. Installation of your Renegade Rack is now complete.

Hard Top Removal Notes

It is not necessary to remove the rack to remove the hard top. The Freedom Panels will lift out normally without much interference from the rack and the main section of the hard top will slide out the back.

Soft Top Removal Notes

IMPORTANT NOTE: The factory license plate holder obstructs the ability to pivot the rack backwards for soft top folding. Warrior offers part #2370 & #2380 'Spare Tire License Plate Mount' to relocate the license plate to the center of the spare tire. WP recommends that you then use dealer part 'Jeep JK OEM License Plate Hole Cover PN 55397112AA' to cover the hole that is exposed by removing the factory license mount.

To fold the soft top you will need to follow these steps:

1. **DO NOT ATTEMPT TO SPLIT AND PIVOT THE RACK SYSTEM WITH THE CARGO BASKET LOADED. In Addition, the soft top will need to be stowed all the way back. There is not enough room under the rack to run the top in 'Sun-Rider' mode.** Remove the (4) 3/8" x 1" carriage bolts from the front mounting plates. Due to the weight of the basket, having an assistant help with this next step is recommended. With a person on both sides of the Jeep, grab the rear legs and pivot them back along with the main basket and then have your assistant hold the basket/legs unit off the ground while the soft top is folded. Alternatively, you could pivot and prop the basket/rear legs unit off the ground with saw horses or something similar.
2. Gently pivot the front basket section forward and it will rest upon stops built into the A-pillar mounts. Fold and stow soft top completely back.
3. Once the soft top is stowed, pivot the front section back into position then have your assistant help pivot the main basket/leg section back to its normal position. Reinstall the 3/8" x 1" carriage bolts with associated hardware and tighten.



If you need further assistance installing your product, please contact us by email at techsupport@warriorproducts.com or call us at (888) 220-6861.

THANK YOU FOR PURCHASING WARRIOR PRODUCTS

QUALITY • INTEGRITY • INNOVATION • SERVICE