



## PPM-5715 JK Heavy Duty Replacement Cross Member

Version 1.0

### GENERAL NOTES:

- These instructions are also available on our website; [www.synergymfg.com](http://www.synergymfg.com). Check the website before you begin for any updated instructions and additional photos for your reference.
- This cross member is designed to be compatible with stock skid plates as well as many aftermarket skids which were designed to fit the factory cross member on 2007-2013 Jeep JK vehicles with gas drive trains (3.8L or 3.6L Pentastar). This part is not compatible with diesel models.
- This installation will cover the installation using factory skidplates. Installation will be similar if aftermarket skid plates are used.

### PARTS LIST:

- (1) 5715 JK HD Replacement Cross Member
- (5) ½-13 UNC x 1.0" long Gr8 hex head bolt
- (5) ½" Flat Washer Gr8

### INSTALLATION

1. Begin by removing the transfer case and transmission skidplate if equipped.
  - All factory skidplates use the same hardware which can be removed with an 18mm socket or wrench.
  - Remove bolts labeled 2, 3, 5 and 6 in Image 1.1 below to remove the factory skidplates.

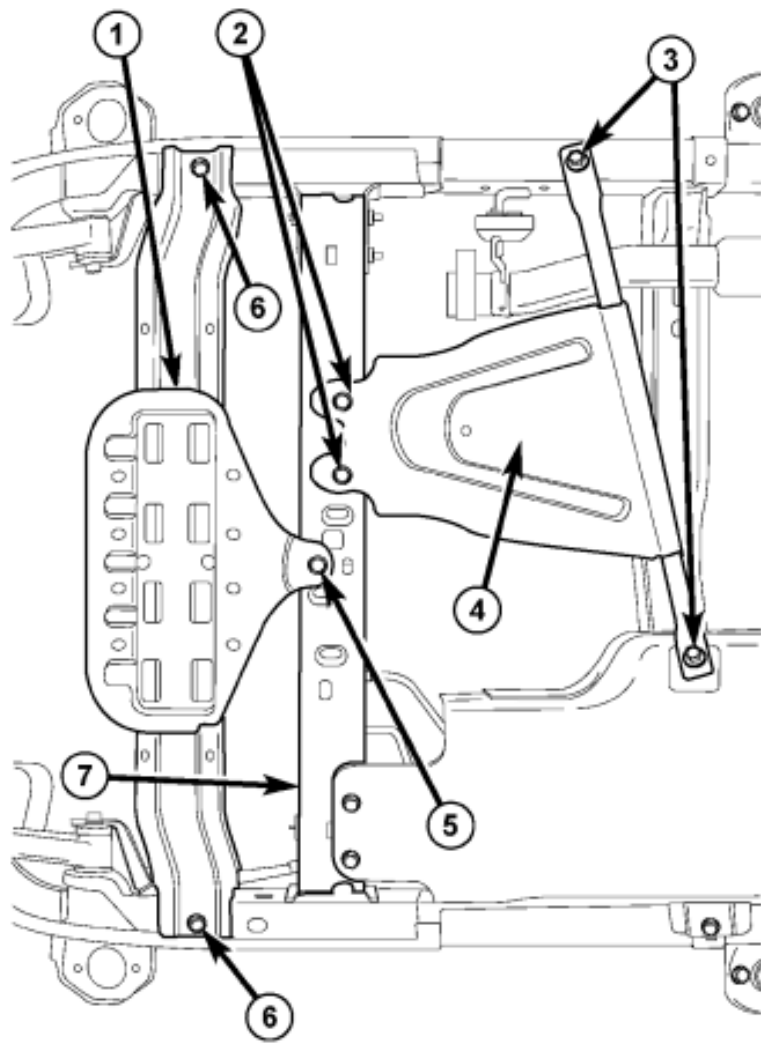

819cdf23

IMG. 1.1

2. After removing the skidplates, remove the 3 nuts securing the transmission mount to the transmission cross member. Use a 16mm socket for removal.



3. Next, using a floor jack/tranny jack or other lifting device, lift the weight of the transmission off the factory cross member. It is usually easiest to lift from under the t-case.
4. With the weight of the drive train off of the factory cross member, remove the left side (drivers side) bolts which secure the cross member to the frame. Use an 18mm wrench / socket for removal. Bolts 1 & 2 in Image 4.1 below.

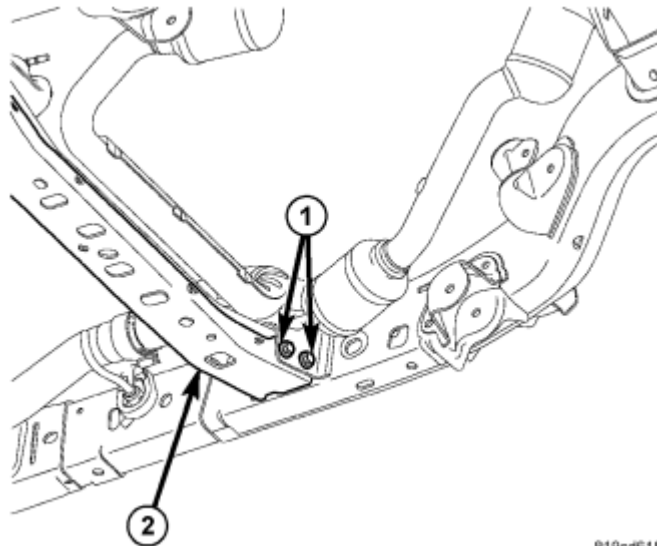

IMG 4.1

819cd518

5. Next, remove the 2 bolts attaching the factory gas tank skid to the factory cross member. Bolts labeled #2 in Img 5.1 below. After removing the gas tank skid hardware, loosen the 2 bolts on the passenger side which attach the transmission cross member to the frame. Bolts labeled #1 in Img 5.1 below. Again, use an 18mm socket / wrench for this.

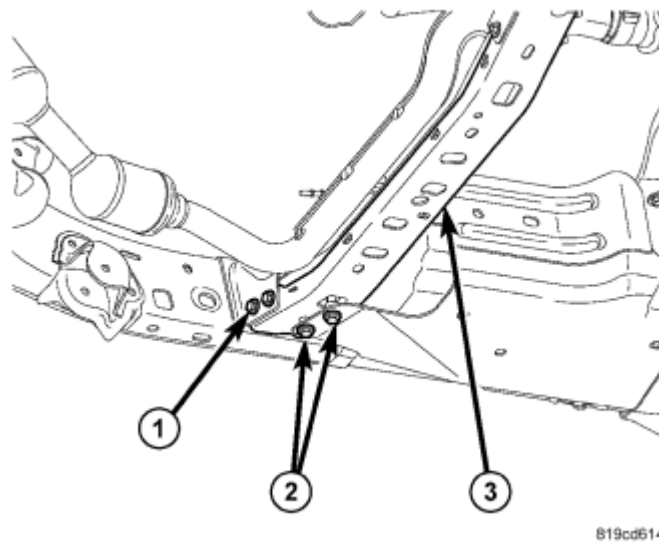

IMG 5.1

6. With all hardware removed, go ahead and remove the factory cross member. It may take a lil tweaking to get it clear from the gas tank skidplate especially if the skidplate has been deformed from off road use.
7. Begin installing the 5715 HD replacement cross member in reverse order of removal of the factory one. Note, it is a good idea to paint or powder coat this part prior to final install to prevent corrosion.
  - Start with the passenger side. Slide cross member into place and install both bolts labeled #1 in Img 5.1 above. Do not install nuts at this time just slide bolts in to hold cross member in position.



- Align the transmission mount with the appropriate holes in the cross member and install the bolts in the passenger side frame mount labeled #1 in Img 4.1 above. Again, do not install nuts at this time just slide bolts in to hold cross member in position



8. Next, go ahead and lower the weight of the transmission onto the cross member and reposition the jack under the cross member itself. Place a jack under the cross member and lift it just before the vehicle itself starts to lift. This step is done to optimize ground clearance as there is significant play in the factory mounting holes on the frame.



9. Install the nuts and tighten all four cross member mounting bolts to 90 ft-lbs.

10. Install the three transmission mount nuts removed in step 2 and torque to 35 ft-lbs.
11. Using two 1/2" bolts and washers provided in the kit, bolt the factory gas tank skid onto the cross member. Torque to 50 ft-lbs
12. Using a combination of factory hardware at the frame attachment points and the 1/2" hardware provided for cross member attachment points, reinstall the factory skidplates. Torque all hardware to 50 ft-lbs.
  - NOTE, when installing on a 2007-2011 model with factory skids, some minor trimming will be needed for reinstallation of the t-case skid. See images below which show trimming.





13. When reinstalling factory skids, it is helpful to keep all the factory skid plate hardware loose until every bolt has been started. This will allow for easier alignment of mounting holes.
14. Once all hardware has been installed and tightened accordingly, installation is now complete.