

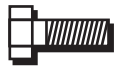

14301 bracket installation Jeep JK 4 door, 2007-

Parts List



(6x) 8mm bolts



(6x) 8mm ID washer



(4x) 8mm Pinch clip



(6 x) U Bracket



(12x) 6mm bolts



(24x) 6mm ID washer



(12x) 6mm nut

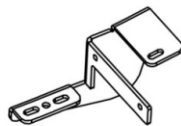
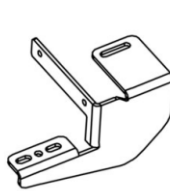
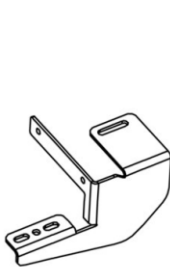

Left side brackets

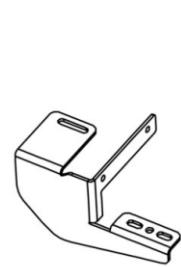
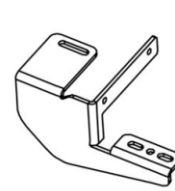
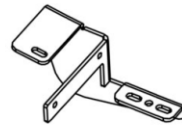

Right side brackets

Tools Required

Ratchet wrench with extension

10mm socket

10mm wrench

13mm socket

Thank You for purchasing this product!

NOTE: Before installation please read and understand these instructions. Please be sure all of the components are included in the package. Please be sure to have a helper to assist you for the initial installation of the step assemblies.

Preperation

If the vehicle had factory step or rocker guard on it the pinch clips will be installed on the floor of the vehicle already. If it did not then they will need to be installed in the openings under the vehicle as shown. Look for the square holes with a round hole next to it. These mounting locations will require the pinch clips. Slip them into the square holes and onto the round hole as shown to the right.

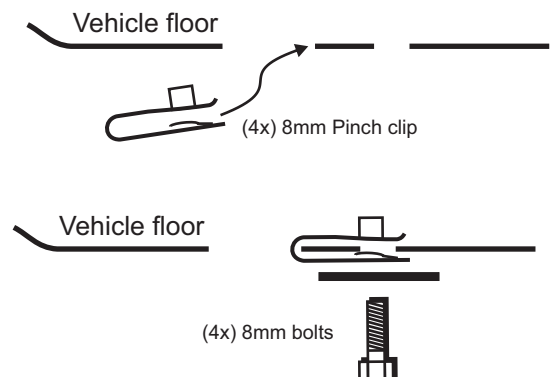

Installation

Locate the correct brackets for the positions on the side of the vehicle. Figure 1 below shows the required brackets for the passenger side. The front two brackets are the same.

Place the brackets up underneath the vehicle aligning the holes in the brackets with the holes in the pinch weld and floor of the vehicle.

Use the 8 mm bolts/washers to loosely install the brackets to the floor. Use the 6 mm bolts/washers/nuts through the pinch weld holes, be sure to use a washer both on the outside of the pinch weld and the inside of the bracket. **(NOTE: Do not tighten the bolts at this time.)**

Note slot size/location

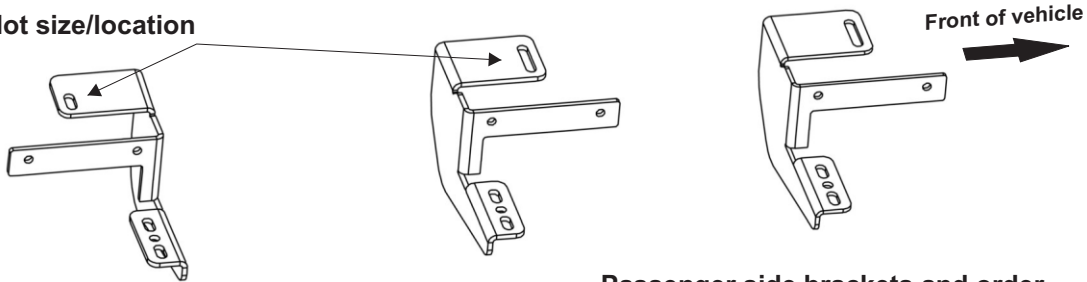

Figure 1

Passenger side brackets and order
NOTE: the front two brackets are the same on both sides.

Place the board being installed carefully on the brackets and use it to help align the position of the brackets on the vehicle **(NOTE: do not bolt up the board at this time)**. Now tighten the brackets, removing the board to tighten any fasteners that are covered by it.

Front of vehicle

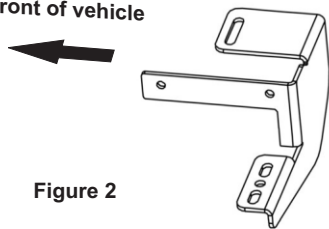
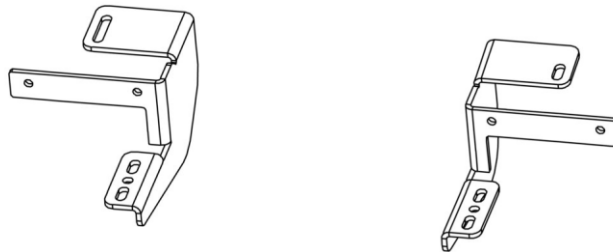

Figure 2

Driver side brackets and order



Repeat for other side.

Finish by installing the boards/steps onto the brackets using the "U" Brackets and 6 mm bolts/washers as shown in Figure 3. The U brackets clamp the sheet metal of the steps and allow adjustment.

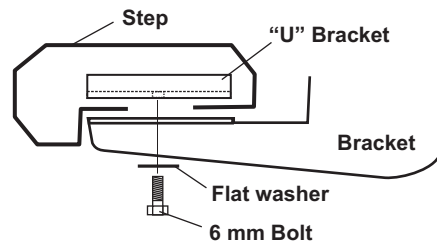

Figure 3

Warranty Information

Rampage products, Inc. warrants to the original purchaser of any step product it manufactures, that the product will be free of defects in material or workmanship for a period of 1 year from date of purchase. Such obligations under this warranty shall be limited to the repair or replacement, at Rampage products discretion, of any assembly or parts which, upon examination by Rampage products, Inc. proves to be defective. All defective items must be returned with proof of purchase to Rampage products, Inc., freight prepaid. This warranty does not cover damage resulting from abuse, misuse, alteration, accident or damage in transit. Rampage products obligations under this warranty are limited to the aforementioned repair or replacement of warranty defects for which the return authorization has been received during the warranty period, and Rampage products, Inc. shall not be liable for any incidental or consequential damages arising from breach of this or any implied warranty.

Rampage Products, Corona, CA Phone: (951) 277-4949 Fax: (951) 277-2295
www.rampageproducts.com