

2360 Boswell Road  
Chula Vista, CA 91914  
Phone 619.216.1444  
Fax 619.216.1474  
E-Mail tech@exploreprocomp.com



## PRO COMP SUSPENSION

### Suspension Systems that Work!

*IMPORTANT: Because this vehicle will be equipped with a rear 4 link suspension. The exhaust system may need to be altered from the rear of the muffler back by a qualified exhaust shop depending on which year/model and exhaust system type the vehicle is equipped with.*

*IMPORTANT: This kit is designed to be installed on a vehicle that already has a slip yoke eliminator kit and CV style driveshaft in place. If your vehicle is not equipped with these items, you must purchase them before installing this kit. Pro Comp offers a slip yoke eliminator kit (PN 4007) and a CV style driveshaft (PN 4042)*

#### Part #

**55794/55794MX**

**'04-'06 4WD Jeep TJ  
Unlimited/ Rubicon**

6 cyl w/ automatic trans w/ Dana  
44 & 35 rear diff and Dana 44 &  
30 front diff

**Stage 3 Long Arm  
4" Lift Kit**

#### Part #

**55795/55795MX**

**'04-'06 4WD Jeep TJ  
Unlimited/ Rubicon**

6 cyl w/manual trans w/ Dana  
44 & 35 rear diff and Dana 44 &  
30 front diff

**Stage 3 Long Arm  
4" Lift Kit**

#### Part #

**55796/55796MX**

**'03-'06 4WD Jeep TJ  
Unlimited/ Rubicon**

6 cyl w/ automatic & manual  
trans w/ Dana 44 & 35 rear diff  
and Dana 44 & 30 front diff

**Stage 3 Long Arm  
4" Lift Kit**

#### Part #

**55797/55797MX**

**'03-'06 4WD Jeep  
Wrangler TJ/ Rubicon**

6 cyl w/ automatic trans w/ Dana  
44 & 35 rear diff and Dana 44 &  
30 front diff

**Stage 3 Long Arm  
4" Lift Kit**

This document contains very important information that includes warranty information and instructions for resolving problems you may encounter. Please keep it in the vehicle as a permanent record.

Box 1-PN 55794/55794MX-1/55795/55795MX-1/55796/55796MX-1/55797/55797MX-1 of 5

Part #	Description	Qty	Illus.	
90-3984	BELLY PAN	1	8	11
90-3985	TRANSMISSION CROSSMEMBER	1	8	11

Box 2-PN 55794/55794MX-2/55795/55795MX-2/55796/55796MX-2/55797/55797MX-2 of 5

90-2764	BRAKE LINE INSULATION HOSE	1	-	-
90-6594	HARDWARE PACK: Brake Line/Relay Bracket	1	-	-
90-3998	RELOCATION BRACKET: Rear Disk Brake Line	1	12	15
70-0250751800	1/4" X 3/4" HEX BOLT USS GR. 8	1	12	15
72-025100816	1/4" GR. 8 STOVER NUT	1	12	15
73-02500030	1/4" SAE GR. 8 FLAT WASHER	2	12	15
70-0371001522	3/8" X 1" GR.5 SELF TAPPING HEX BOLT	2	4	9
70-0311001800	5/16" X 1" GR. 8 HEX BOLT	4	4	9
72-03100100512	5/16" NYLOCK NUT	4	4	9
73-03100034	5/16" SAE GR. 8 FLAT WASHER	8	4	9
90-6550	HARDWARE PACK: Long Arm Frame	1	-	-
70-0504001800	1/2" X 4" GR. 8 HEX BOLT	12	7	11
72-050100816	1/2" GR.C STOVER NUT	12	7	11
73-05000832	1/2" SAE FLAT WASHER	24	7	11
70-0501251800	1/2" X 1 1/4" GR. 8 COUNTER SUNK BOLT	14	8	11
72-050100816	1/2" X GR. C STOVER NUT	12	8	11
73-05000830	1/2" SAE FLAT WASHER	12	8	11
90-3988	BELLY PAN FRAME MOUNT: Drvr (Regular TJ)	1	5,6,7,8	10,11
90-3993	BELLY PAN FRAME MOUNT: Pass (Regular TJ)	1	5,6,7,8	10,11
90-5038	<u>OR</u> BELLY PAN FRAME MOUNT: Drvr (Unlimited)	1	5,6,7,8	10,11
90-5042	BELLY PAN FRAME MOUNT: Pass (Unlimited)	1	5,6,7,8	10,11
90-3879	BELLY PAN FRAME MOUNT TOOL	1	6	10
90-6576	HARDWARE PACK: Transmission Mount Crossmember	1	-	-
72-043100816	7/16" STOVER NUT	4	8	11
73-04300830	7/16" SAE FLAT WASHER	4	8	11

Box 3-PN 55794/55794MX-3/55795/55795MX-3/55796/55796MX-3/55797/55797MX-3 of 5

90-3580	TRACK BAR DROP BRACKET	1	3	8
90-6487	HARDWARE PACK: Track Bar Drop Bracket	1	-	-
50C375HCS8Y	1/2" X 3 3/4." GR. 8 HEX BOLT	2	3	8
50NUCZ	1/2" STOVER NUT	4	3	8
50NWSAZ	1/2" FLAT WASHER	8	3	8
50C250HCS8Y	1/2" X 2 1/2" GR. 8 HEX BOLT	1	3	8
50C200HCS8Y	1/2" X 2" GR. 8 HEX BOLT	1	3	8
90-2603	TRACK BAR SPACER (.625" X .500 X .063 WALL)	1	-	-
YJ400-1	PITMAN ARM	1	-	-
90-6540	HARDWARE PACK: Sway Bar	1	-	-
90-3726	SWAY BAR RETAINER	1	16	15
90-3728	SWAY BAR HOLDER	1	18	17
90-4152	LOCKING PIN ROUND	1	19,20	18,19
90-1092	OFFSET SWAY BAR MOUNT	2	18	17

Part #	Description	Qty	Illus.	Page
90-2009	STRIGHT SWAY BAR: Rear	2	22	19
90-2638	7/8" OFFSETSWAY BAR: Front	2	14,17	15,16
90-6024	<b>HARDWARE PACK: Sway Bar Disconnect</b>	1	-	-
37C150HCS5Z	3/8" X 1 1/2 GR. 8 HEX BOLT	2	18	17
37C250HCS5Z	3/8" X 2 1/2 GR. 8 HEX BOLT	2	19	18
37CNNE5Z	3/8" GR. 8 NYLON NUT	4	18,19	17,18
37NWSAZ	3/8" SAE FLAT WASHER	4	18,19	17,18
37NWUS8Y	3/8" USS GR. 8 FLAT WASHER	2	18,19	17,18
90-6530	<b>HARDWARE PACK: Sway Bar Disconnect</b>	1	-	-
600006	5/8" BLACK HOURGLASS BUSHING	4	16	17
61150	SLEEVE 5/8" X 3/8" X 1.480"	2	16	17
60859H	SLEEVE	2	16	17
600001	5/8" BLACK HOURGLASS BUSHING	4	16	17
15-11309	<b>BUMP STOP</b>	4	15	16
90-6523	<b>HARDWARE PACK: Sway Bar Quick Disconnect</b>	2	-	-
90-2593	<b>QUICK DISSCONNECT PIN</b>	1	-	-
72-050200812	1/2"-20 NYLOCK NUT	1	19	18
73-05000034	1/2" SAE FLAT WASHER	1	19	18
73-06200034	5/8" SAE FLAT WASHER	1	19	18
90170A212	<b>LOWER LOCKING PIN</b>	1	19,20	18,19
90-3579	<b>SWAY BAR CLAMP</b>	1	16,18	15,16
90-2596	<b>SWAY BAR CLAMP SPACER</b>	1	18	17
70-0251251800	1/4"-20 X 1 1/4" HEX BOLT GR.8	1	18	17
72-025100512	1/4"-20 NYLOCK NUT	1	18	17
90-2010	<b>SLEEVE</b>	1	-	-
90-6475	<b>HARDWARE PACK: Rear Shock Relocation Bracket</b>	1	-	-
90-1867	<b>REAR SHOCK RELOCATOR</b>	2	23	21
90-2381	<b>SHOCK SPACER</b>	2	23	21
90-6476	<b>HARDWARE PACK: Rear Shock Relocation Bracket</b>	1	-	-
.120C600HCS1Y	12mm-1.75 X 60mm HEX BOLT 10.9	2	23	21
.120NWHDY	12mm HARDENED FLAT WASHER	4	23	21
.120CNNEZCL10	12mm-1.75 NYLOCK NUT	2	23	21
31C100HCS8Y	5/16" X 1" GR 8 HEX BOLT	2	23	21
31NWHDY/SAE	5/16" HARDENED SAE FLAT WASHER	4	23	21
31CNUCZ	5/16" STOVER NUT	2	23	21
90-2627	<b>FRONT TRACK BAR JEEP: W/ DANA 44</b>	1	-	-
90-6208	<b>HARDWARE PACK: Front Track Bar</b>	1	-	-
HRS MX 10T	<b>ROD END, .750-16 THREAD W/JAM NUT</b>	1	-	-
15-11080	<b>TRACK BAR BUSHING, URETHANE</b>	2	-	-
90-2249	<b>SPACER, .750" OD X .438" ID X 1.600"</b>	1	-	-
90-6501	<b>HARDWARE PACK: Bump Stop Spacer</b>	1	-	-
96-2647	<b>2" X 1/2" BUMPSTOP SPACER</b>	4	15	16

Part #	Description	Qty	Illus.	Page
90-2736	TRACK BAR BRACKET SPACER: (.625" X .700)	1	-	-
90-3986	AXLE LOCK RELAY BRACKET: Front	1	4	9
90-3987	AXLE LOCK RELAY BRACKET: Rear	1	4	9
Box 4-PN 55794/55794MX-4/55795/55795MX-4/55796/55796MX-4/55797/55797MX-4 of 5				
90-6505	HARDWARE PACK: Front Upper Arm	1	-	-
90-2626	3/4" X .156 WALL X 2.0"	2	13	15
15-11310	BUSHING JEEP UPPER ARM	4	13	15
90-2609	UPPER FRONT ARMS: Male	2	13	15
90-2604	UPPER FRONT ARMS: Female	2	13	15
90-6504	HARDWARE PACK: Upper Front Arms	1	-	-
100FNFJZ	1"-14 UPPER CONTROL ARM JAM NUT	2	13	15
90-3783	LOWER CONTROL ARM FRONT: Drvr	1	9	12
90-3789	LOWER CONTROL ARM FRONT: Pass	1	-	-
90-6552	HARDWARE PACK: Lower Control Arm Pinch Clamp	1	-	-
70-0311751800	5/16" X 1 3/4" GR.8 HEX BOLT	4	8,9	12
72-031100816	5/16" GR. C STOVER NUT	4	8,9	12
73-03100830	5/16" SAE WASHERS	8	8,9	12
90-3802	LOWER CONTROL ARM REAR: Drvr	1	-	-
90-3796	LOWER CONTROL ARM REAR: Pass	1	9	12
90-6566	HARDWARE PACK: Lower Control Arm Rod Ends	1	-	-
JMX14T	ROD END	4	9,10	12
90-4153	MISALIGNMENT SPACER: Lower Control Arm	8	9,10	11
90-6567	HARDWARE PACK: Lower control Arm Rod Ends	1	-	-
70-0563751800	9/16" X 3 3/4" GR 8 HEX BOLTS	4	9,10	12
72-056100816	9/16" GR 8 STOVER NUTS	4	9,10	12
73-05600830	9/16" GR 8 SAE WASHERS	8	9,10	12
90-6039	HARDWARE PACK: Lower Control Arm Bushings & Sleeves	1	-	-
90-2310	SLEEVE	4	9,10	12
15-11255	TAPERED BUSHING	8	9,10	12
Box 5-PN 55794/55794MX-5/55795/55795MX-5/55796/55796MX-5/55797/55797MX-5 of 5				
90-6505	HARDWARE PACK: Rear Upper Arm	1	-	-
90-2626	3/4" X .156" WALL X 2"	2	14	16
15-11310	BUSHING JEEP UPPER ARM	4	14	16
90-2673	UPPER ARMS: REAR	2	14	16
90-6553	HARDWARE PACK: Rear Upper Arm Rod Ends	1	-	-
JMX-12T	ROD END	2	14	16
SJNR12	NUTS	2	14	16

Part #	Description	Qty	Illus.	Page
90-2449	SPACER, .750" OD X .438" ID X 1.600" LONG	4	14	16
90-6551	<b>HARDWARE PACK: Axel Truss</b>	1	-	-
70-0310751800	5/16" X 3/4" GR 8 HEX BOLT	4	11	13
73-03100830	5/16" GR 8 SAE FLAT WASHER	4	11	13
70-0372251800	3/8" X 2 1/4" GR 8 HEX BOLT	8	11	13
72-037100816	3/8" UNITORQUE NUT	8	11	13
73-03700030	3/8" HARDENED FLAT WASHER	16	11	13
72-043100816	7/16" STOVER NUT	1	11	13
70-0563001800	9/16" X 3" GR 8 HEX BOLTS	2	11	13
72-056100816	9/16" STOVER NUTS	2	11	13
73-05600830	9/16" GR 8 SAE WASHERS	4	11	13
90-3757	REAR AXLE TRUSS	1	11	13
90-4158	REAR AXLE VENT TUBE	1	11	13
90-3781	DANA 44 REAR DIFFERENTIAL SPACER PLATE	1	11	13
90-3767	REAR AXLE TRUSS CLAMPS	2	11	13
90-3893	DANA 35 REAR DIFFERENTIAL SPACER PLATE	1	11	13
90-3894	OVERLAP PLATE	2	11	13
90-6577	<b>HARDWARE PACK: Axle Truss Overlap Plate</b>	1	-	-
37C100HCS8Y	3/8" X 1" GR. 8 HEX BOLT	4	11	13
37CNUCZ	3/8" STOVER NUT	4	11	13
37NWHDY	3/8" SAE HARDENED FLAT WASHER	8	11	13
90-6641	<b>HARDWARE PACK: Upper arm frame brace</b>	1	-	-
90-5134	UPPER ARM FRAME BRACE	2	-	-

**FOLLOWING PARTS ARE USED IN CONJUNCTION WITH THIS KIT. THEY ARE PACKAGED AND MUST BE ORDERED SEPARATELY.**

7450	STAINLESS STEEL BRAKE LINE KIT	1	-	-
55497	COIL SPRING, PAIR (FRONT)	1	15	16
55498	COIL SPRING, PAIR (REAR)	1	-	-
324515	ES 3000 SHOCK ABSORBERS (FRONT)	2	15	16
323509	ES 3000 SHOCK ABSORBERS (REAR)	2	-	-
	<i>OR</i>			
924515	ES 9000 SHOCK ABSORBERS (FRONT)	2	15	16
923509	ES 9000 SHOCK ABSORBERS (REAR)	2	-	-
	<i>OR</i>			
MX6021	MX-6 SHOCK ABSORBERS (FRONT)	2	15	16
MX6106	MX-6 SHOCK ABSORBERS (REAR)	2	-	-

Optional Equipment Available from your **Pro Comp** Distributor!

Winch Spacer, 1" (Front) - Pair: 55496

Steering Stabilizer: 219505

Slip Yoke Eliminator Kit: 4007

Jeep TJ CV Style Driveshaft: 4042

Also, check out our outstanding selection of **Pro Comp** tires to compliment your new installation!

## Introduction:

- ◆ **This installation requires a professional mechanic!**
- ◆ We recommend that you have access to a factory service manual for your vehicle to assist in the disassembly and reassembly of your vehicle. It contains a wealth of detailed information.
- ◆ Prior to installation, carefully inspect the vehicle's steering and driveline systems paying close attention to the tie rod ends, ball joints, wheel bearing preload, pitman and idler arm. Additionally, check steering-to-frame and suspension-to-frame attaching points for stress cracks. The overall vehicle must be in excellent working condition. Repair or replace all worn or damaged parts!
- ◆ Read the instructions carefully and study the illustrations before attempting installation! You may save yourself a lot of extra work.
- ◆ Check the parts and hardware against the parts list to assure that your kit is complete. Separating parts according to the areas where they will be used and placing the hardware with the brackets before you begin will save installation time.
- ◆ Check the special equipment list and ensure the availability of these tools.
- ◆ Secure and properly block vehicle prior to beginning installation.
- ◆ **ALWAYS** wear safety glasses when using power tools or working under the vehicle!
- ◆ Use caution when cutting is required under the vehicle. The factory undercoating is flammable. Take appropriate precautions. Have a fire extinguisher close at hand.
- ◆ Foot pound torque readings are listed on the Torque Specifications chart at the end of the instructions. These are to be used unless specifically directed otherwise. Apply thread lock retaining compound where specified.
- ◆ ***Please note that while every effort is made to ensure that the installation of your Pro Comp lift kit is a positive experience, variations in construction and assembly in the vehicle manufacturing process will virtually ensure that some parts may seem difficult to install. Additionally, the current trend in manufacturing of vehicles results in a frame that is highly flexible and may shift slightly on disassembly prior to installation. The use of pry bars and tapered punches for alignment is considered normal and usually does not indicate a faulty product. However, if you are uncertain about some aspect of the installation process, please feel free to call our tech support department at the number listed on the cover page. We do not recommend that you modify the Pro Comp parts in any way as this will void any warranty expressed or implied by the Pro Comp Suspension company.***

### PLEASE NOTE:

Due to differences in manufacturing, dimensions and inflated measurements, tire and wheel combinations should be test fit prior to installation. Tire and wheel choice is crucial in assuring proper fit, performance, and the safety of your Pro Comp equipped vehicle. For this application, a wheel not to exceed 8" in width with a minimum backspacing of 3.25" must be used. Additionally, a quality tire of radial design, not exceeding 33" tall X 12.5" wide is recommended. Please note that the use of a 33" X 12.5" tire may require fender modification. Violation of these recommendations will not be endorsed as acceptable by Pro Comp Suspension and will void any and all warranties either written or implied.

***NOTE: If you are planning to install a differential air locker you will need to use a 90 degree 3/16" compression fitting to clear the axle truss (90-3757) and the accompanying parts and hardware.***

## INSTALLATION INSTRUCTIONS:

1. Position your vehicle on a smooth, flat, hard surface (i.e. concrete or asphalt). Block the rear tires and set the emergency brake.
2. Measure and record the distance from the center of each wheel to the top of its fender opening. Record below.
3. Place the vehicle in neutral. Place your floor jack under the front axle and raise the vehicle. Place jack stands under the front body mounts and lower the vehicle onto the stands. Place your floor jack under the rear axle and raise the vehicle. Place jack stands under the rear body mounts and lower the vehicle onto the stands. Remove the jack and place the vehicle back in gear, set the emergency brake.

### DISASSEMBLY:

4. Unbolt and remove the front track bar from the vehicle.
5. Unbolt the rear track bar and remove it from the vehicle.
6. Remove the cotter pin and nut from the drag link at the pitman arm. Using the proper tool, disconnect the pitman arm from the drag link
7. Remove the nut and washer from the steering gear shaft. Remove pitman arm using a proper pitman arm removal tool.
8. Disconnect the front sway bar end links and remove from the vehicle.
9. Disconnect the rear sway bar end links and remove from the vehicle.
10. Unbolt and remove the rear sway bar from the rear axle. Save the hardware for reuse.
11. Perform steps 12 through 17 on the front and rear of the vehicle.
12. Remove the wheels and tires from the vehicle.
13. Support the differential with your floor jack and remove the **OE** shock absorbers. It may be necessary to raise the differential housing slightly

to facilitate their removal.

**NOTE: Be sure to support the axle while the springs and shocks are removed.**

14. Carefully lower axle until coil spring is free from upper mount. Remove coil spring retainer bolt and remove the coil spring.

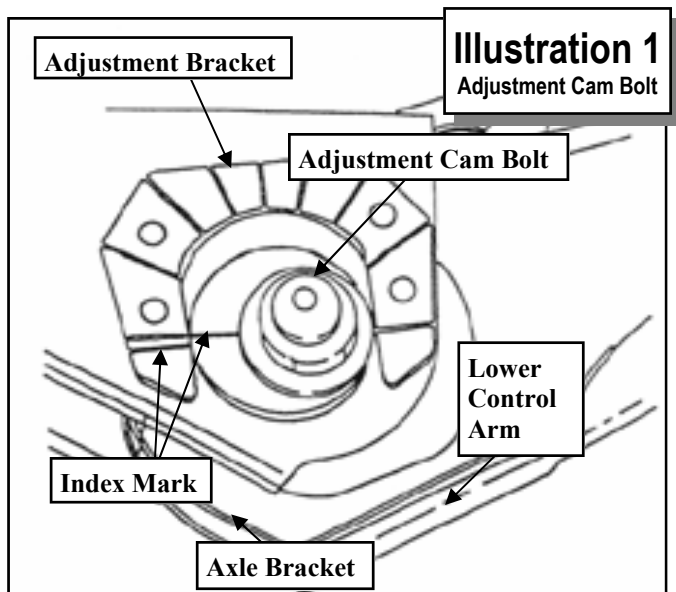
**NOTE: After removal of the springs support the axles with jack stands or pole jacks.**

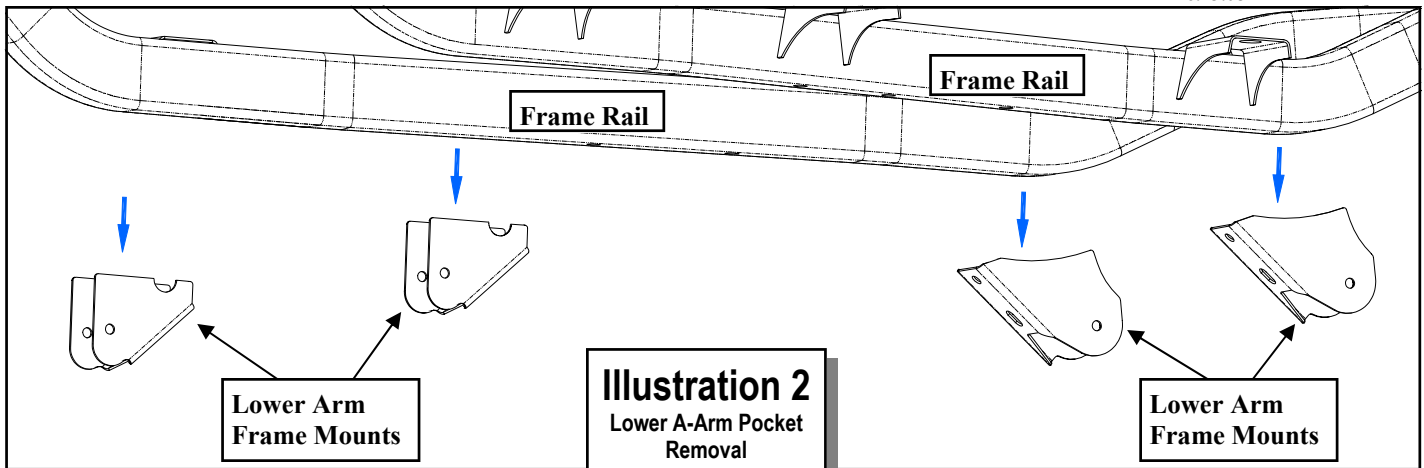
15. Remove the **OE** bump stops from the bump stop mounting cups.
16. Unbolt the factory bump stop mounting cup from the frame. Save the hardware for reuse.
17. With the axles fully supported, locate the adjustment cam bolts, positioned on front of existing lower control arms. (Make an index mark as shown in ILLUSTRATION 1, for installation reference. FRONT ONLY). Unbolt and remove the lower control arms from the vehicle.

**NOTE: If the vehicle is equipped with ABS brakes remove sensor wire from the in-board side of the lower control arm.**

### FRAME ALTERATIONS:

18. **THIS STEP IS TO BE PERFORMED ON RUBICON MODELS ONLY.** Unbolt the axle lock relay bracket from the driver side frame rail.
19. Support the transfer case skid plate. The





transfer case and transmission are supported by the skid plate. Before removing the skid plate ensure that the transmission is properly supported. Remove the (6) bolts connecting the skid plate to the frame. The skid plate will not be reused.

20. Using a suitable cutting tool, (abrasive cutoff wheel, Sawz-all, etc.) cut off the front and rear lower arm mounting pockets as shown in ILLUSTRATION 2. After cutting the lower arm mounting pockets, sand the frame

smooth. Clean the area thoroughly and paint the exposed metal with a good quality paint.

**IMPORTANT!:** Be sure not to cut into fuel or brake lines. **DO NOT** cut into the frame rail. This will weaken the frame structure considerably.

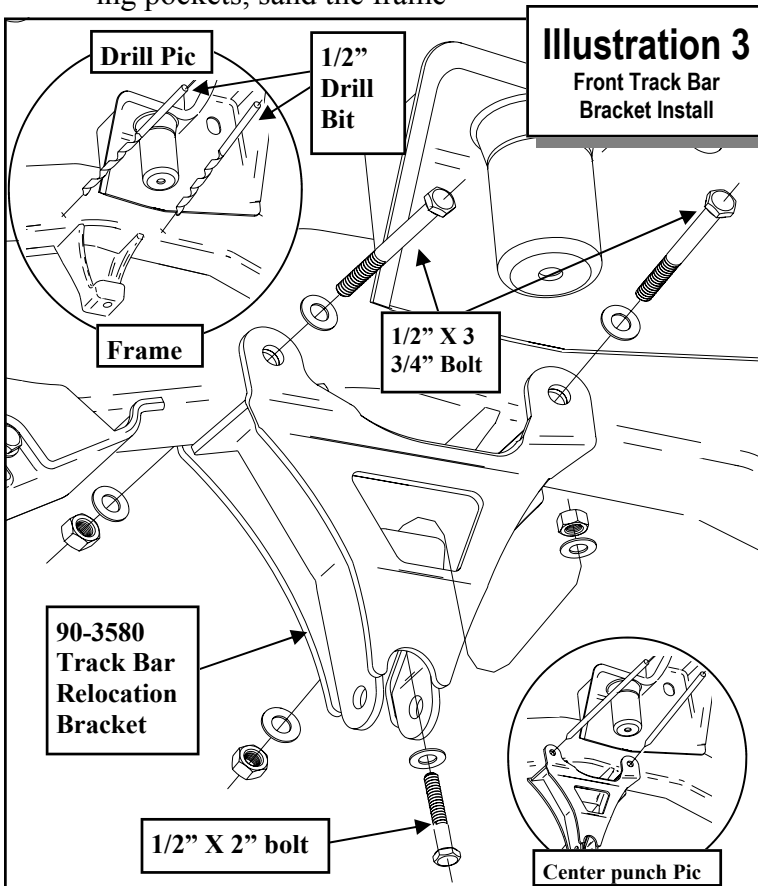
21. The factory nutserts in the bottom of the frame rails will need to be removed.

22. Drill out the factory nutsert using a 9/16" drill bit. The drilling will separate the inside portion of the nutserts from the body.

23. Once the insides of the nutserts are loose, with a cold chisel or a cut off wheel, knock off the bodies of the nutserts that hang below the frame.

24. Remove the inside portion of the nutserts from the frame rail.

**NOTE:** A magnet and compressed air will aid in the nutsert removal. Blow the nutserts down the rail toward the round frame hole that can be accessed by a magnet for removal.



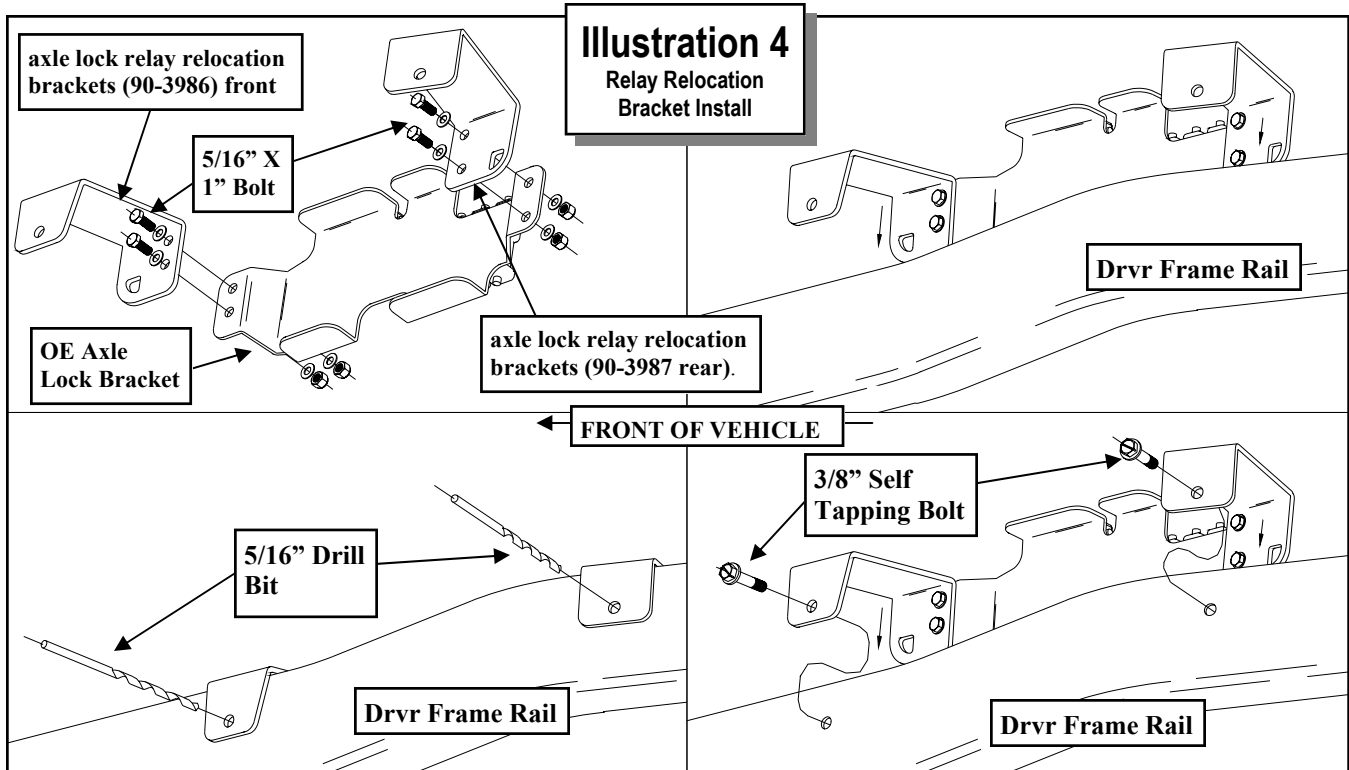
**ASSEMBLY:**

25. Install the new pitman arm (YJ 400) using the OE retaining nut. Torque the retaining nut to 185 ft./lbs.

26. Reinstall the draglink onto the pitman arm. Torque to 60 ft./lbs.

27. Install the front track bar bracket (90-3580) into the OE mounting position using the 1/2" X





2\"/>

**NOTE:** If you have previously drilled the OE lower hole out to 5/8\"/>

28. With the track bar bracket (90-3580) bolted in place, use the two upper holes as guide holes to mark the frame for drilling. See ILLUSTRATION 3.

29. Center punch the previously made marks in the frame and drill out to 1/2\"/>

30. Secure the upper holes of the bracket using the 1/2\"/>

**STEPS 31 THROUGH 34 ARE TO BE PERFORMED ON RUBICON MODELS ONLY.**

31. Relocate the axle lock relay bracket using the axle lock relay relocation brackets (90-3986 front and 90-3987 rear). Place the relocation brackets over the top of the driver side frame rail, in between the floor, as shown in ILLUSTRATION 4.

**NOTE:** The side with the single hole will go on the outside of the frame rail.

32. Secure the factory relay bracket to the new relocation brackets (90-3986 front and 90-3987 rear) using the provided (4) 5/16\"/>

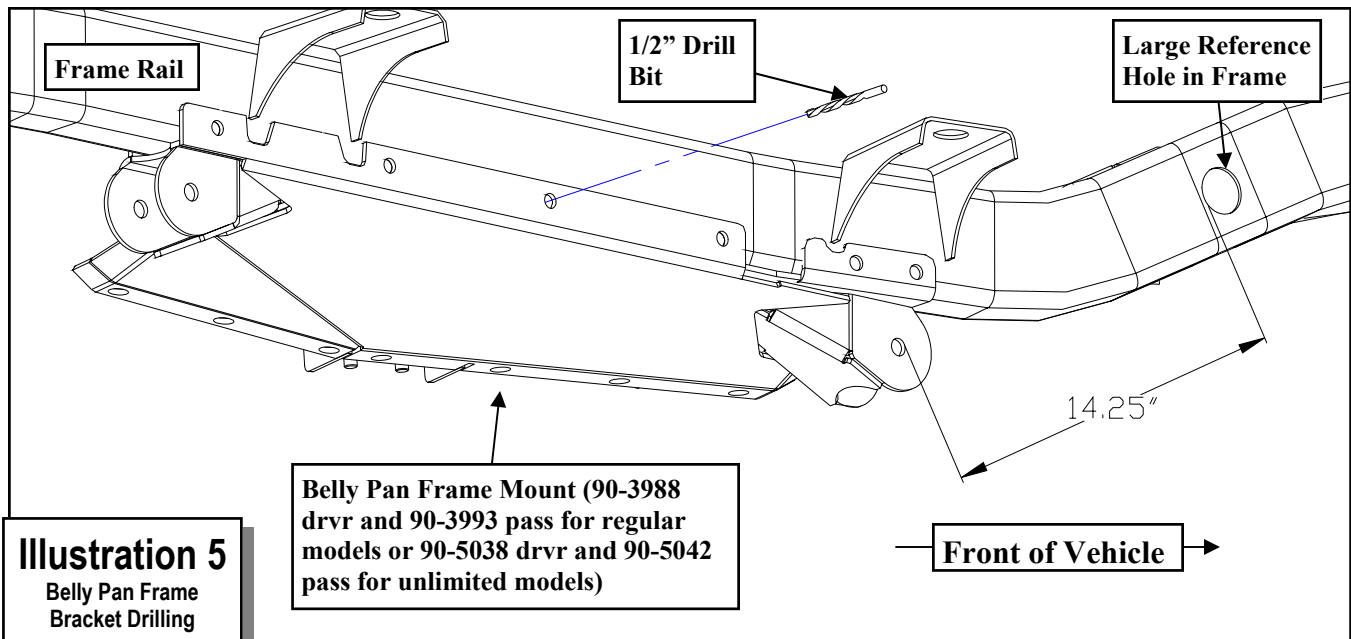
33. With the brackets in place, using the holes in the outside of the relocation brackets as a guide, drill through the outside wall of the frame rail using a 5/16\"/>

34. Secure the relocation brackets to the frame rail using the (2) provided 3/8\"/>

**IMPORTANT!:** Be sure that the brake, vacuum and fuel lines are free from contact with any newly installed or existing parts as rubbing may cause these lines to fail.

**BELLY PAN INSTALLATION:**

35. Test fit the belly pan frame mount brackets (90-3988 drvr and 90-3993 pass for regular models or 90-5038 drvr and 90-5042 pass for unlimited models) by clamping them to the



**Illustration 5**  
Belly Pan Frame  
Bracket Drilling

**Belly Pan Frame Mount (90-3988  
drv and 90-3993 pass for regular  
models or 90-5038 drv and 90-5042  
pass for unlimited models)**

frame rail. Locate the frame mount brackets by measuring **14 1/4"** from the edge of the large hole in the frame, forward of the belly pan mounting position, to the edge of the front control arm mounting hole in the frame mount bracket. See ILLUSTRATION 5.

36. Repeat on the remaining side of the vehicle.
37. With the frame mount brackets clamped in place, test fit the belly pan (90-3784). The belly pan mounting holes should match up with the frame mounting bracket holes. Temporarily se-

cure the belly pan in place using (4) **1/2" X 1 1/4"** countersunk bolts and hardware in the (4) corner holes. If the holes do not line up, loosen the clamps and readjust the assembly until the desired fit is achieved.

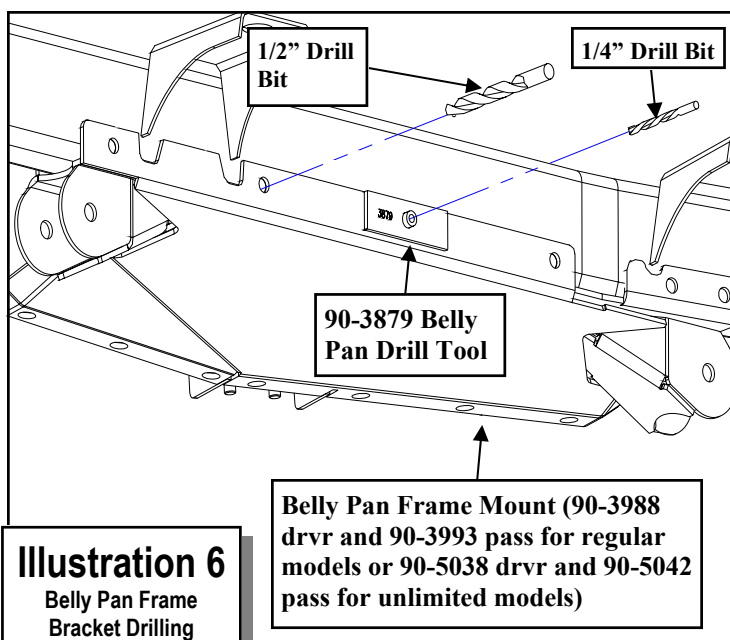
**NOTE: The belly pan is temporarily bolted into place at this time to prevent any movement of the frame brackets during the drilling process.**

38. Using the frame mounting brackets (90-3988 drv and 90-3993 pass for regular models or 90-5038 drv and 90-5042 pass for unlimited models) as a guide drill through the holes in the frame mount bracket using a **1/2"** drill bit. Drill **ONLY** through the outside wall of the frame rail. Repeat for all holes in the frame mount bracket. See ILLUSTRATION 5.

39. Install the frame drill tool (90-3879) into the previously drilled **1/2"** hole and hold it against the frame mounting brackets and frame rail. See ILLUSTRATION 6.

40. With the drill tool held firmly in place, drill a **1/4"** hole through the inside frame rail wall. Repeat for all the previously drilled **1/2"** holes. See ILLUSTRATION 6.

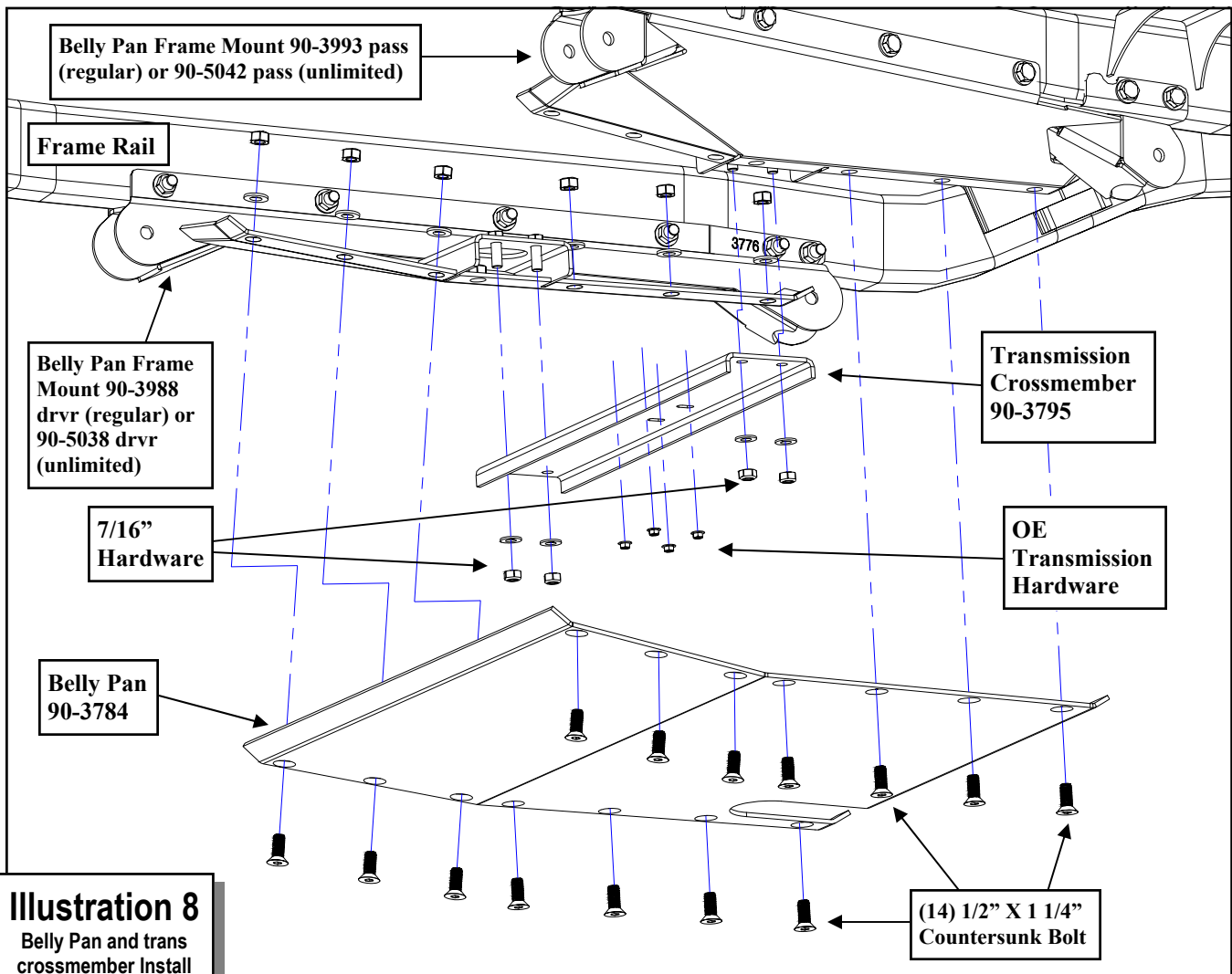
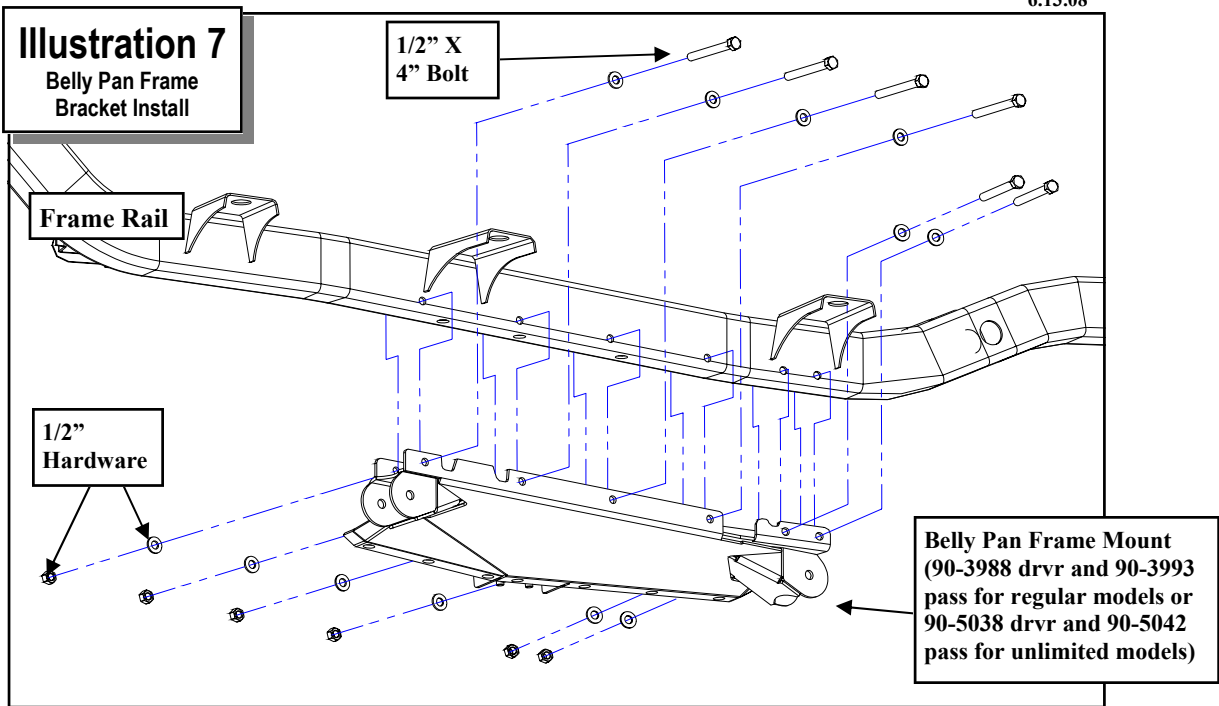
**NOTE: Be very careful not to drill through any wiring, fuel or brake lines.**

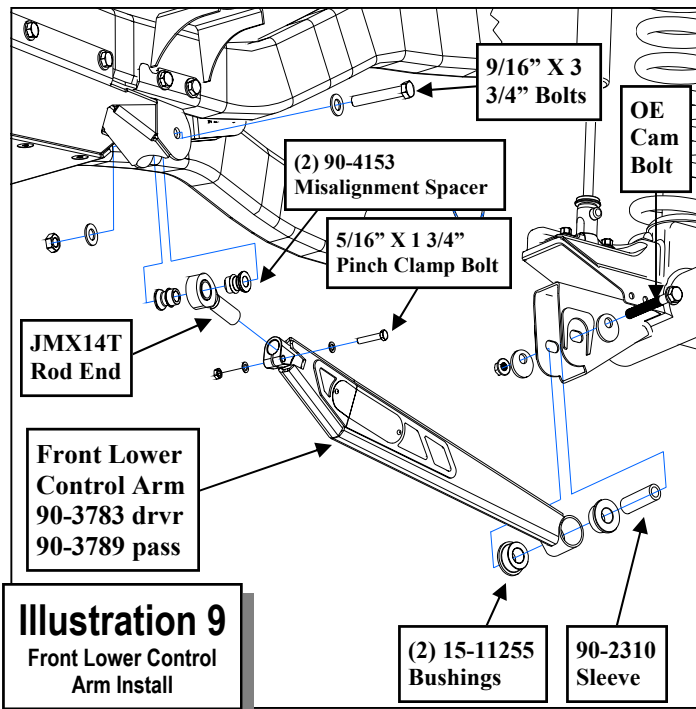


**Illustration 6**  
Belly Pan Frame  
Bracket Drilling

**90-3879 Belly  
Pan Drill Tool**

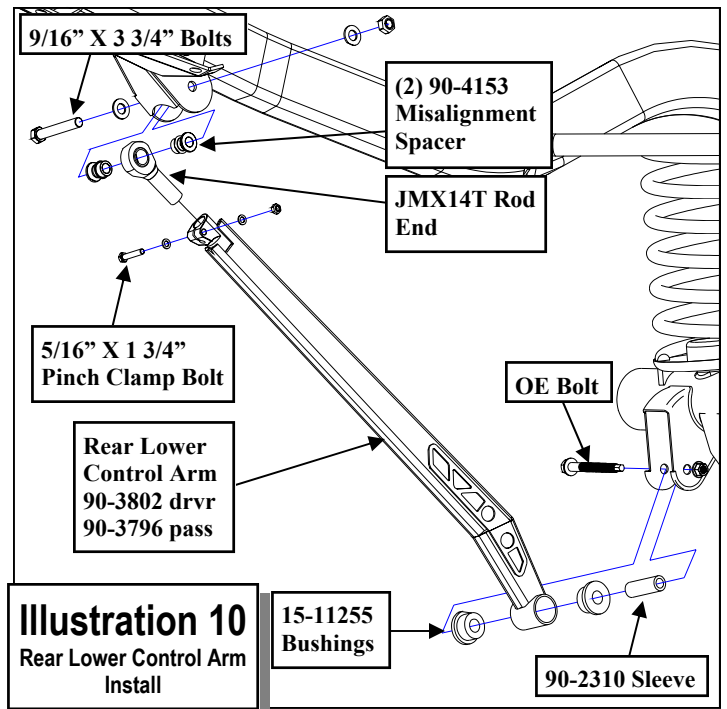
**Belly Pan Frame Mount (90-3988  
drv and 90-3993 pass for regular  
models or 90-5038 drv and 90-5042  
pass for unlimited models)**





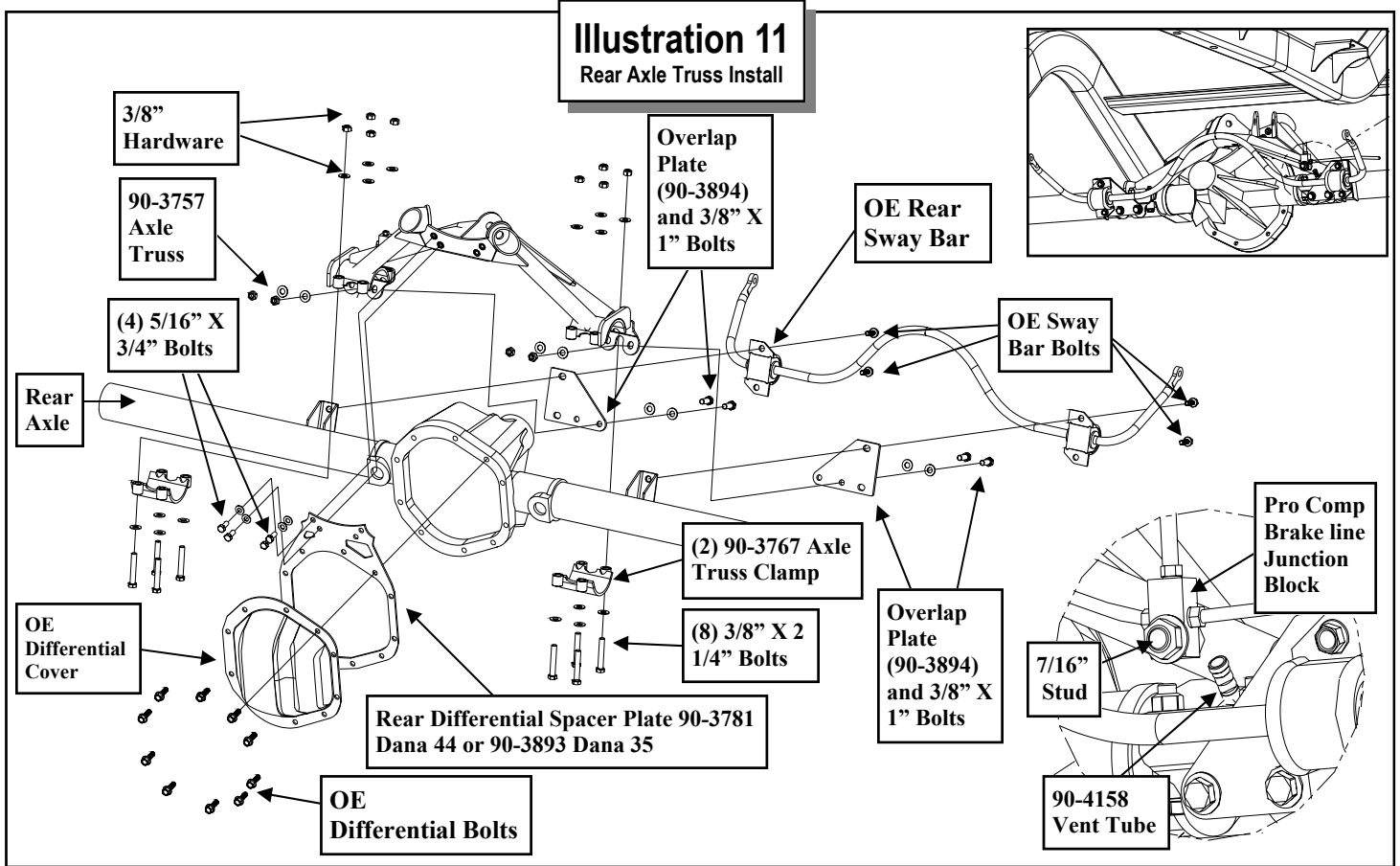
**Illustration 9**  
Front Lower Control Arm Install

41. Drill out the 1/4" inner frame rail holes using a 1/2" drill bit. See ILLUSTRATION 6.
42. Secure the frame brackets (**90-3988 drv** and **90-3993 pass** for regular models or **90-5038 drv** and **90-5042 pass** for unlimited models) to the frame using the supplied 1/2" X 4" bolts and hardware. See ILLUSTRATION 7. Torque the mounting hardware to 65 ft./lbs.
43. Unbolt and remove the belly pan from the vehicle.
44. Install the new transmission crossmember (**90-3795**) by placing the crossmember over the mounting studs on the belly pan frame mounts. Secure using the supplied 7/16" nuts and washers. Only tighten the 7/16" nuts a few turns. See ILLUSTRATION 8.
45. Lower the transmission onto the crossmember (**90-3795**), align the transmission mounting holes and secure using the OE hardware. Torque the transmission mounting hardware according to the factory manuals specifications. See ILLUSTRATION 8.
46. Torque the transmission crossmember (**90-3795**) hardware to 55 ft./lbs.



**Illustration 10**  
Rear Lower Control Arm Install

47. If necessary install the slip yoke eliminator kit and install the CV style rear driveshaft at this time. Refer to the instructions provided with the kit.
  48. Raise the belly pan (**90-3784**) back into place and secure to the belly pan frame mounts and secure using the (14) supplied 1/2" X 1 1/4" counter sunk bolts and hardware. See ILLUSTRATION 8.  
**IMPORTANT! Due to the fact that the countersunk bolts create increased friction on their mating surfaces, we recommend holding the Allen head end and tightening the nut.**
- LOWER CONTROL ARMS:**
- Check the arm length chart on page 22 for suggested lower arm measurements
49. Perform steps **49** through **55** on the front and rear of the vehicle.
  50. Insert the bushings (**15-11255**) and sleeve (**90-2310**), using a thin layer of lubricant, into the (4) new lower control arms (**90-3783 front drv**, **90-3789 front pass**, **90-3802 rear drv** and **90-3796 rear pass**) as shown in ILLUSTRATION 9



& 10.

51. Install the rod ends (**JMX14T**) into the pinch clamp end of the rear lower arms. Install the pinch clamp **5/16" X 1 3/4"** bolts and hardware. See ILLUSTRATION 9 & 10. Adjust the arm length according to the arm length chart on page 22 and tighten the jam nut.

52. Insert the (2) misalignment spacers per arm (**90-4153**) into the rod end. See ILLUSTRATION 9 & 10.

53. Install the rod end of the lower arm to the mounting pockets on the belly pan frame bracket using the supplied **9/16" X 3 3/4"** bolts and hardware. See ILLUSTRATION 9 & 10.

54. Install the bushing end of the lower arms to the mounting pockets on the axle using the supplied **OE** bolts and hardware. Torque the **OE** bolt to 85 ft./lbs. See ILLUSTRATION 9 & 10.

55. Torque the **OE** lower control arm mounting bolts according to factory specifications and the

supplied **9/16"** bolts to 130 ft./lbs.

### REAR AXLE TRUSS:

56. With the rear axle fully supported unbolt the rear upper control arms from the rear axle.

57. Remove the rear axle vent tube and unbolt the brake line junction block from the rear axle.

58. Drain the rear axle fluid and remove the differential cover.

59. With the axle clear of accessories, test fit the axle truss assembly.

60. Test fit the rear axle differential spacer plate (**90-3781 for Dana 44 or 90-3893 for Dana 35**) to the rear axle to ensure proper alignment. Secure using the **OE** bolts. See ILLUSTRATION 11.

61. Place the rear axle truss (**90-3757**) on top of the differential housing. Line up and install the

**5/16" X 3/4"** bolts that secure the rear axle differential spacer plate to the rear axle truss. Secure the truss to the rear axle using the **(2)** axle truss clamps **(90-3767)**, **3/8" X 2 1/4"** clamp bolts and hardware. See ILLUSTRATION 11.

62. A new vent tube hole will need to be drilled on the front, driver side of the rear axle.

63. Use the hole in the axle truss **(90-3757)**, next to the **7/16"** brake line mounting stud, on the front side of the rear axle as a guide to drill a new vent hole in the rear axle tube using a **3/8"** drill bit. See ILLUSTRATION 11.

**NOTE: When drilling into an oil cavity, pack the flutes of the drill bit with grease to catch all the metal shavings.**

64. Once the new vent tube hole is drilled, unbolt and remove the axle truss. Clean and remove any remaining metal chips from inside and outside the rear axle.

65. Run a bead of silicone around the new vent tube hole in the rear axle. Also seal the original vent tube hole in the rear axle.

**NOTE: There is no pressure on the rear axle vent system so do not overload the holes with silicone.**

66. Install the **3/8"** vent tube **(90-4158)** through the hole in the rear axle truss. See ILLUSTRATION 11.

67. Reinstall the axle truss **(90-3757)** by lining up and reinstalling the **5/16" X 3/4"** bolts that secure the rear axle differential spacer plate **(90-3781 for Dana 44 or 90-3893 for Dana 35)** to the rear axle truss. Reinstall the axle clamps **(90-3767)** to the rear axle. Secure the clamps using the supplied **3/8" X 2 1/4"** bolts and hardware. See ILLUSTRATION 11.

**NOTE: The vent tube should line up with the newly drilled hole on the rear axle.**

**NOTE: Be sure the inside of the vent tube is clear of silicone after installation.**

68. Install the **(2)** overlap plates **(90-3894)** to the axle truss using the **(4)** **3/8" X 1"** bolts and hardware. Reinstall the sway bar to its original rear axle mounting position. Secure the sway bar

frame mounts to the overlap plates and rear end using the previously removed **(4)** OE sway bar bolts. See ILLUSTRATION 11.

69. Torque the rear axle truss **(Except the (4) 5/16" bolts)**, overlap plate and sway bar mounting hardware according to the torque chart on page 23 or according to manufacturers recommendations.

70. Unbolt and remove the rear axle differential spacer plate **(90-3781 for Dana 44 or 90-3893 for Dana 35)**. See ILLUSTRATION 11.

71. Run a bead of silicone along the differential cover mating surface.

72. Reinstall the differential spacer plate **(90-3781 for Dana 44 or 90-3893 for Dana 35)** to the rear axle truss using the **(4) 5/16" X 3/4"** bolts and hardware. See ILLUSTRATION 11.

73. Run another bead of silicone on the face of the differential cover.

74. Raise the differential cover into place and secure using the OE bolts. Torque the differential spacer plate and cover hardware according to the torque chart on page 23 or manufacturers specifications. See ILLUSTRATION 11.

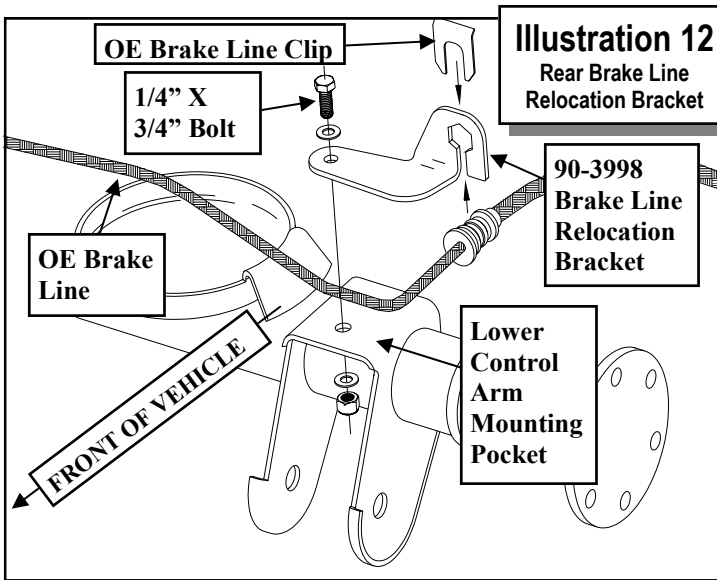
75. Unbolt the rear rubber brake line from the frame. Save the hardware for reuse.

76. Detach the rear rubber brake line from the factory metal brake lines on the frame and the rear axle.

77. Thoroughly clean all mating surfaces and secure the supplied 90 degree brake line mounting bracket **(90-1031)** to the frame using the previously removed OE bolt. At the upper end of the brake line **(7450)**, insert the threaded end of the brake line from the bottom through the supplied brake line mounting bracket **(90-1031)**. Install the supplied jam nut to threaded end of the brake line **(7450)** and tighten. Position the line so it doesn't make contact with any other parts.

78. Connect the new brake line **(7450)** to the existing frame metal brake line and tighten.

79. Slip the junction block end of the new brake



driver side brake line to the front of the axle. Bolt the new brake line bracket (90-3998) to the hole in the top of the rear axle lower control arm mounting pocket using the provided 1/4"-20 X 3/4" bolt and hardware. Secure the brake line to the new bracket (90-3998) using the previously removed clip. See ILLUSTRATION 12. Be sure the brake line does not contact any parts. If so use the provided 1/4" rubber hose (90-2764) as a sheath for the brake lines. This hose can cut and applied as needed.

**IMPORTANT: MAKE SURE BRAKE LINES ARE CLEAN AND DRY OF ANY MATERIAL BEFORE ABS BRAKE BLEEDING AND REASSEMBLY. BE VERY CAREFUL NOT TO LET THE MASTER CYLINDER RUN DRY! WITH ABS BRAKES THIS SITUATION WILL DAMAGE THE SYSTEM!**

line (7450) over the 7/16" stud on the front of the axle truss. Secure using the supplied 7/16" nut from pack (90-6551). See ILLUSTRATION 11.

80. Attach the Pro Comp brake line junction block to the existing rear axle metal brake lines and tighten.

**NOTE: Depending on brake application, the steel lines may need to be carefully rerouted to attach to the junction block.**

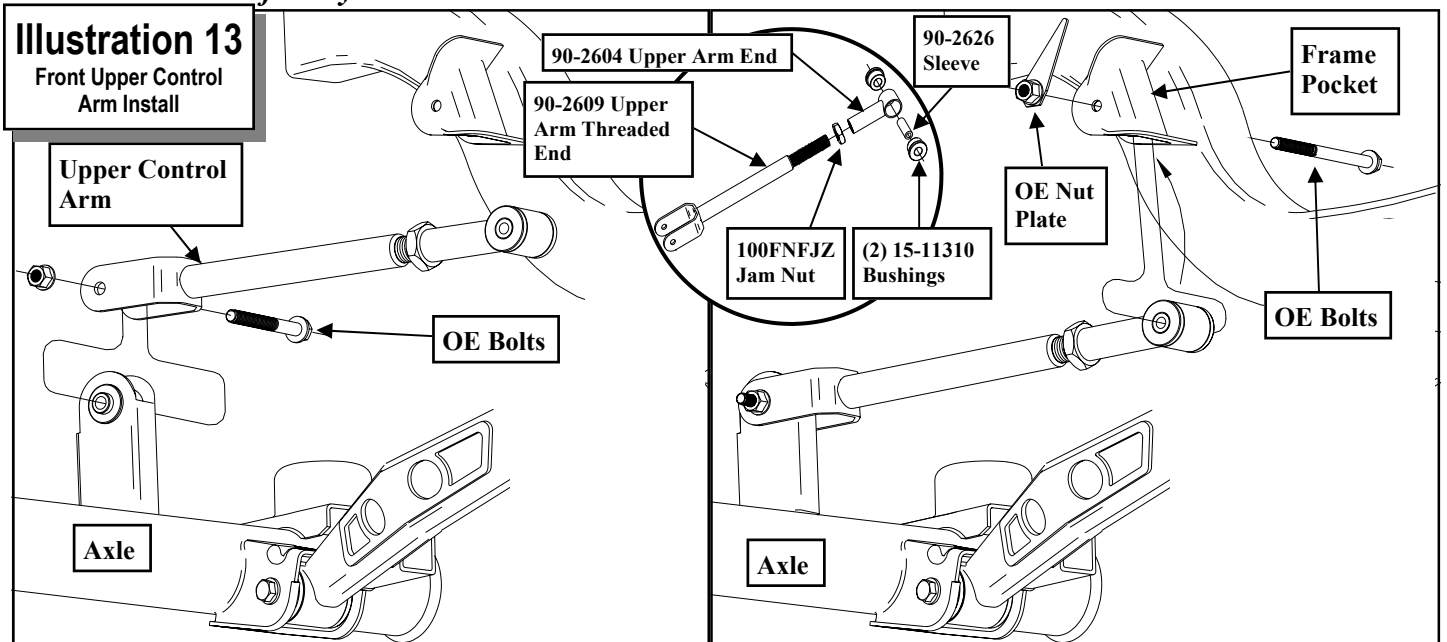
**NOTE: FOR MODELS WITH FACTORY INSTALLED DISC BRAKES ONLY, Unclip the driver side metal brake line from the factory bracket. Relocate the**

### UPPER CONTROL ARMS:

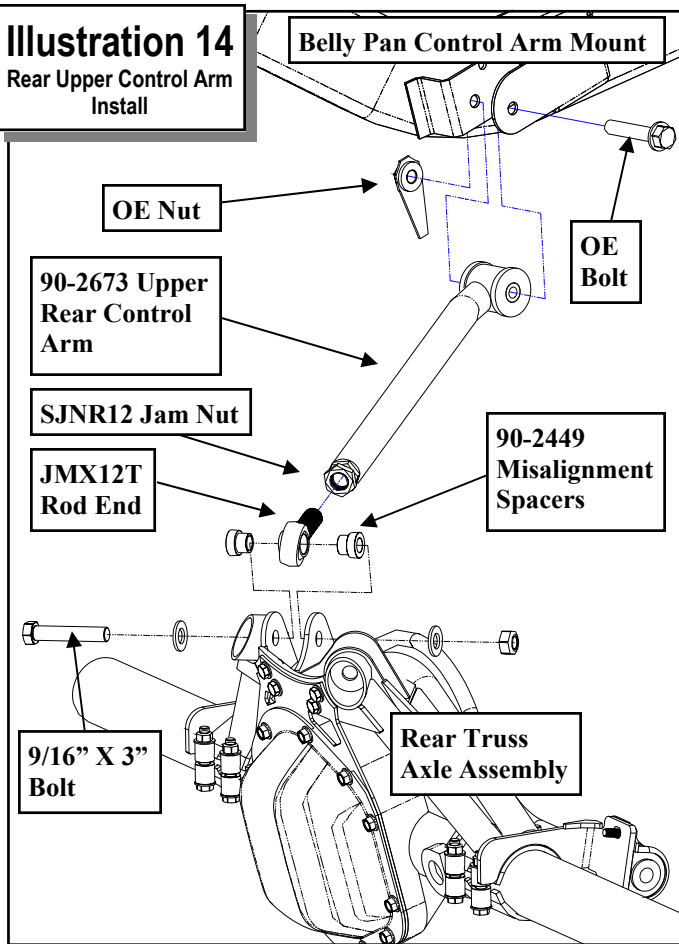
Check the arm length chart on page 22 for suggested upper arm measurements

81. With the front and rear axles fully supported unbolt and remove the front and rear upper control arms from the vehicle.

82. Install the bushings (15-11310) and sleeves (90-2626) into the female end of the front upper



**Illustration 14**  
Rear Upper Control Arm  
Install



control arms (90-2604). See ILLUSTRATION 13.

83. Thread the upper control arm jam nut (100FNFJZ) onto the male end of the upper control arms (90-2609). See ILLUSTRATION 13.

84. Assemble the female ends (90-2604) and male ends (90-2609) of the upper control arms. See ILLUSTRATION 13. Adjust the arm length according to the arm length chart on page 22 and tighten the jam nut.

85. Install the bushing end of the upper arm to the mounting pockets on the frame using the previously removed OE hardware. See ILLUSTRATION 13.

86. Install the clevis end of the upper arm to the mounting pockets on the front axle using the OE bolts and hardware. See ILLUSTRATION 13.

87. Assemble the rear upper control arms (90-2673) using bushings (15-11310) and sleeves (90-2626). See ILLUSTRATION 14.

88. Install the rod end (JMX12T) into the remaining end of the rear upper arms (90-2673) with the jam nut (SJNR12) as shown in ILLUSTRATION 14. Adjust the arm length according to the arm length chart on page 22 and tighten the jam nut.

89. Insert the spacers (90-2449) into the rod end. See ILLUSTRATION 14.

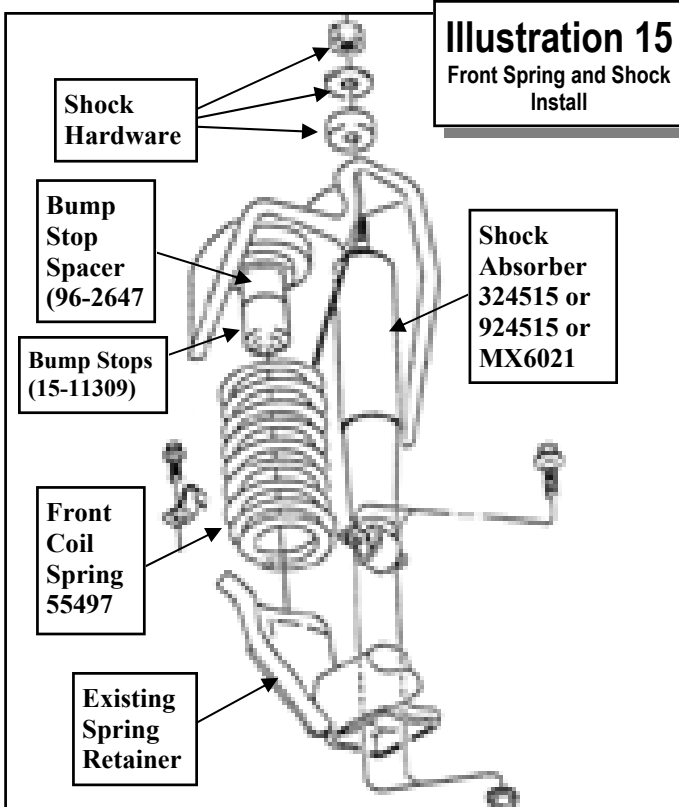
**NOTE: Install frame brace (90-5134) at this time. See enclosed frame brace instructions.**

90. Install the bushing end of the upper arm to the mounting pockets on the frame using the previously removed OE hardware. See ILLUSTRATION 14.

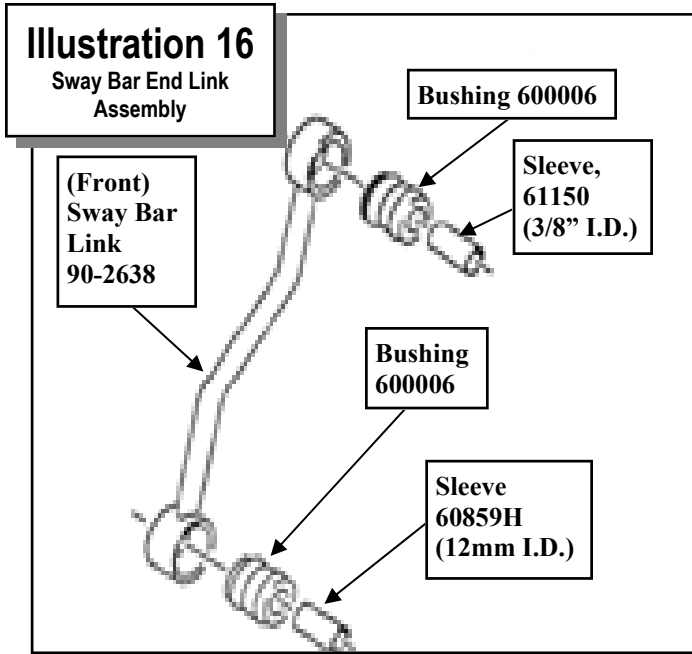
91. Install the rod end of the upper arm to the mounting pockets on the rear axle truss using the supplied 9/16\"/>

**NOTE: Centering of the rear axle under the vehicle and pinion angle adjustment are done using these rod ends.**

**Illustration 15**  
Front Spring and Shock  
Install



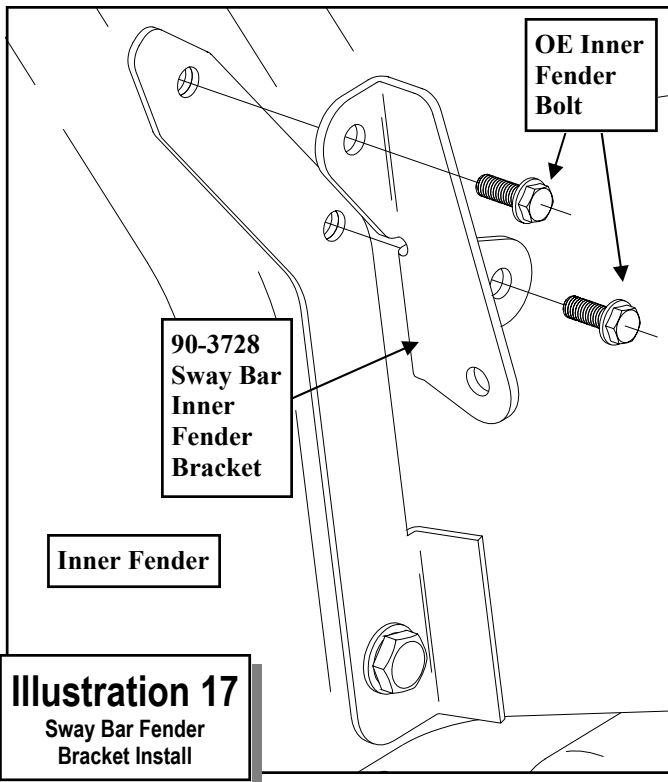




92. Torque the **OE** upper control arm mounting bolts according to factory specifications and the supplied **9/16"** bolts to 130 ft./lbs.

**FRONT BRAKE LINE:**

93. At the driver side, unbolt the brake line bracket from the frame rail. locate the rubber

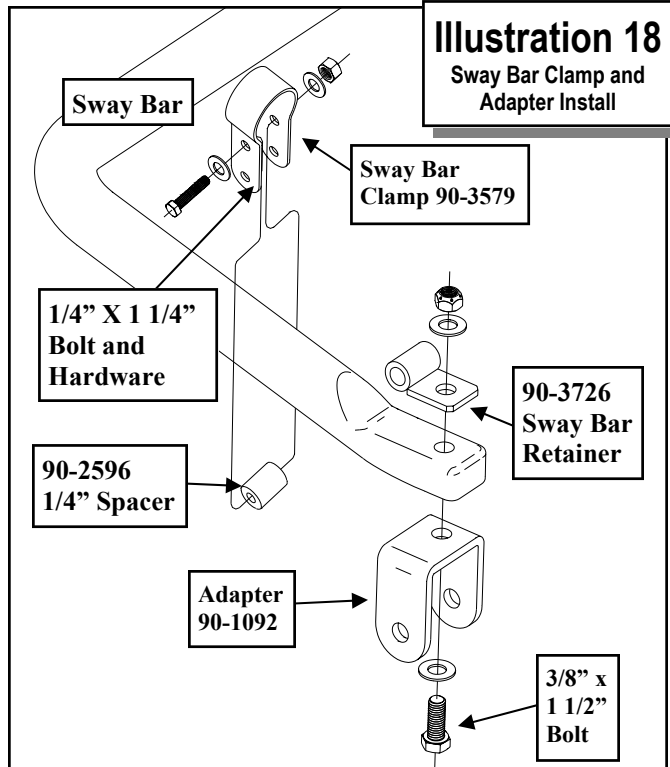


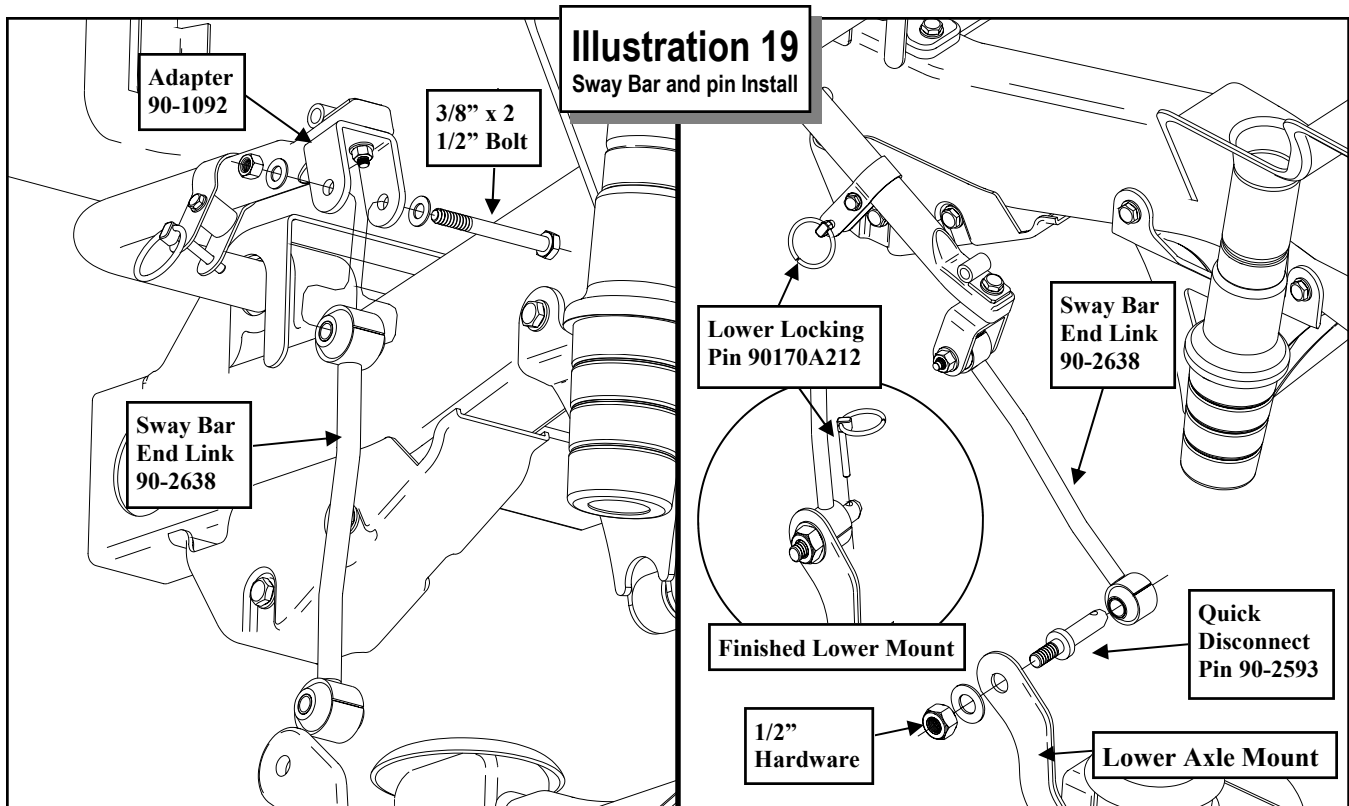
brake hose that runs from caliper to frame. Pinch it closed with vise grips or a small "C" clamp and detach it from the caliper and factory metal line. Plug or cover the caliper opening and remove the brake line from the vehicle.

94. Thoroughly clean all mating surfaces and secure the supplied 90 degree brake line mounting bracket (**90-1031**) to the frame using the previously removed **OE** bolt. At the upper end of the brake line (**7450**), insert the threaded end of the brake line from the bottom through the supplied brake line mounting bracket (**90-1031**). Install the supplied jam nut to the threaded end of the brake line and tighten the nut, securing it to the brake line bracket. Connect the new brake line (**7450**) to the existing frame metal brake line and tighten. Install the brake line to the caliper using the factory banjo bolt and new crush washer. Position the line so it doesn't make contact with any other parts. Make sure brake lines are clean and dry of any material before ABS brake bleeding.

95. Repeat on the remaining side of vehicle.

***BLEEDING OF THE BRAKE SYSTEM SHOULD BE DONE ACCORDING TO A***





**JEEP FACTORY SERVICE MANUAL.**

**IMPORTANT: BE VERY CAREFUL NOT TO LET THE MASTER CYLINDER RUN DRY! WITH ABS BRAKES THIS SITUATION WILL DAMAGE THE SYSTEM!**

**IMPORTANT: Move the control arm assembly up and down to its limits several times to check for binding and to ensure that there are no interference or pinching problems with the brake lines and/or ABS wiring.**

**FRONT AND REAR BUMP STOPS:**

96. Bolt the front bump stop cups to the frame using the previously removed OE bolt and install the 1/2" X 2" bump stop spacer (96-2647). See ILLUSTRATION 15.

97. Install the supplied bump stops (15-11309) into the OE bump stops mounting cups. See ILLUSTRATION 15.

**NOTE: To properly seat the newly installed bump stops, carefully lower the weight of the vehicle onto the bump stops.**

**FRONT COIL SPRINGS:**

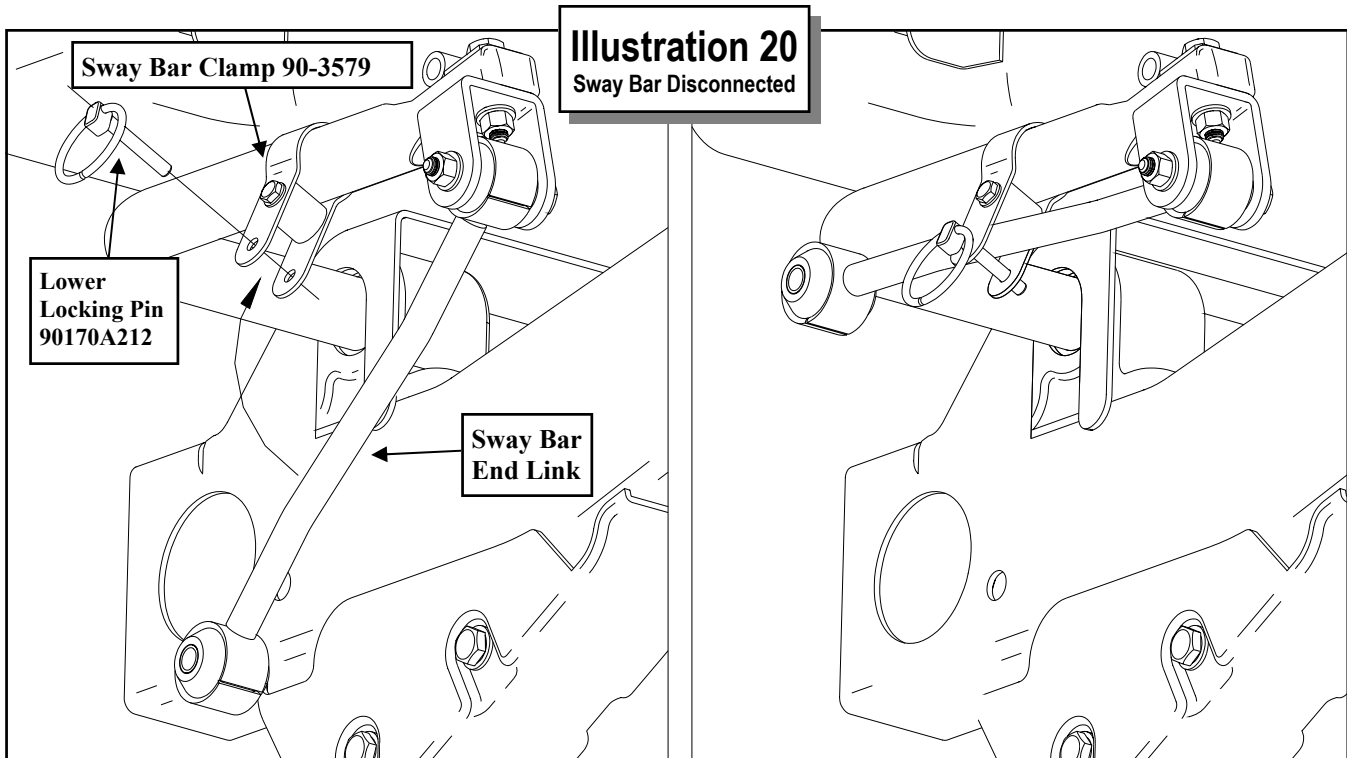
98. Position new front coil spring (55497) on axle pad. Reinstall coil spring retainer and bolt. Torque to 16 ft./lbs. Raise the axle into position until coil spring seats in upper mount, then raise axle another 2". Install new longer shock absorbers (324515 or 924515 or MX6021) as shown in ILLUSTRATION 15. Torque upper shock nuts to 17 ft./lbs. and lower nuts to 20 ft./lbs.

**FRONT SWAY BAR:**

99. Remove the OE inner fender bolts shown in ILLUSTRATION 17. Save the hardware for re-use.

100. Install the sway bar inner fender bracket (90-3728) into the inner fender using the previously removed OE bolts into their original holes. See ILLUSTRATION 17.

101. Install hour glass bushings (600006) and (61150) sleeve in the top and (60859H) sleeve in the bottom of the sway bar end links (90-2638).



102. Install sway bar clamp (90-3579) onto sway bar approximately 6" from the end of the bar with the holes facing down. Secure it to the sway bar using the 1/4"-20 X 1 1/4" bolt, spacer (90-2596) and hardware in the top hole (closest to the sway bar). Leave hardware loose at this time. See ILLUSTRATION 18.

103. Install the adapter (90-1092) and sway bar retaining bracket (90-3726) onto the sway bar using the 3/8" X 1 1/2" bolt and hardware as shown in ILLUSTRATION 18.

104. Install sway bar end links (90-2638) into the adapter (90-1092) using the 3/8" X 2 1/2" bolt and hardware.

**NOTE:** The jog in the sway bar will face towards the outside of the vehicle. See ILLUSTRATION 19.

105. Secure the quick disconnect pin (90-2593) to the factory lower sway bar mount location using the supplied 1/2" washer and 1/2" nylock nut.

**NOTE:** The pin will face toward the inside of the vehicle. See ILLUSTRATION 19.

106. Slide the lower end of the sway bar end link

onto the quick disconnect pin and secure with the locking pin 90170A212 and 5/8" washer. See ILLUSTRATION 19.

107. Repeat on the remaining side of the vehicle.

108. Temporarily install the front wheels and turn lock to lock to check for interference.

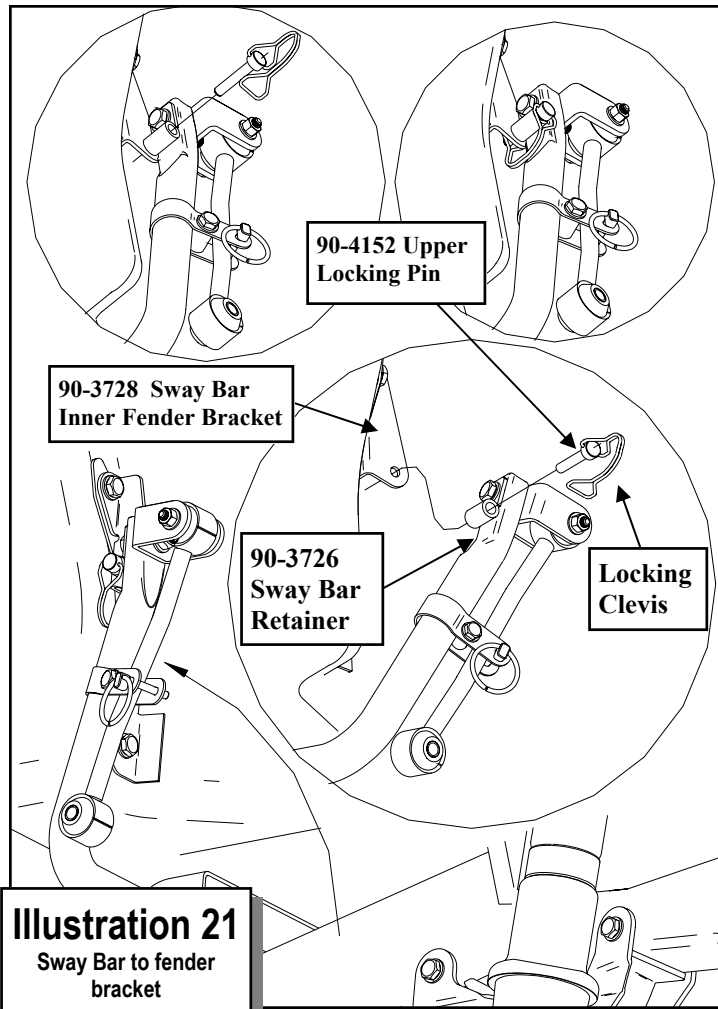
#### **When Disconnected:**

109. When disconnecting the sway bar links, swing the end links up into the previously installed clamp on the sway bar above. Secure the sway bar end link (90-2638) into the clamp (90-3579) using the previously removed locking pin 90170A212. See ILLUSTRATION 20.

110. Once the sway bar has been raised into the clamp and secured the 1/4" x 1 1/4" bolt and hardware can be tightened down. See ILLUSTRATION 20.

111. Repeat on the remaining side of the vehicle.

112. Secure the sway bar to the sway bar inner fender bracket (90-3728) by inserting the upper locking pin (90-4152) through the sway bar re-



taining bracket (90-3726) and the inner fender bracket. See ILLUSTRATION 21.

113. Lock the pin (90-4152) in place by securing the clevis over the opposite end of the locking pin. See ILLUSTRATION 21.

114. Cycle steering lock to lock and inspect steering, suspension and driveline systems for proper operation, tightness and adequate clearance. Recheck brake hose/fitting for leaks. Be sure all hoses are long enough.

#### **FRONT TRACK BAR INSTALLATION:**

Check the arm length chart on page 22 for the suggested front track bar measurement

115. Install the rod end (HRSMX10T) into the track bar with the jam nut (SJNR12). Adjust the

track bar according to the arm length chart on page 22 and tighten the jam nut.

116. Insert the sleeve (90-2603) into the rod end of the front track bar (90-2627).

**NOTE: The sleeve may be a tight fit and may need to be pressed in.**

117. Install the front track bar bushings (15-11080) and sleeve (PN 90-2249) into the track bar (PN 90-2627).

118. Install the front track bar to the passenger side axle mount. Using the previously removed OE bolt. Torque this bolt to manufacturers specifications

119. Bolt the front track bar to the newly installed track bar bracket (90-3580). Secure using the provided 1/2" X 2 1/2" bolt and hardware. Torque the bolt to 90 ft./lbs.

#### **REAR COIL SPRINGS:**

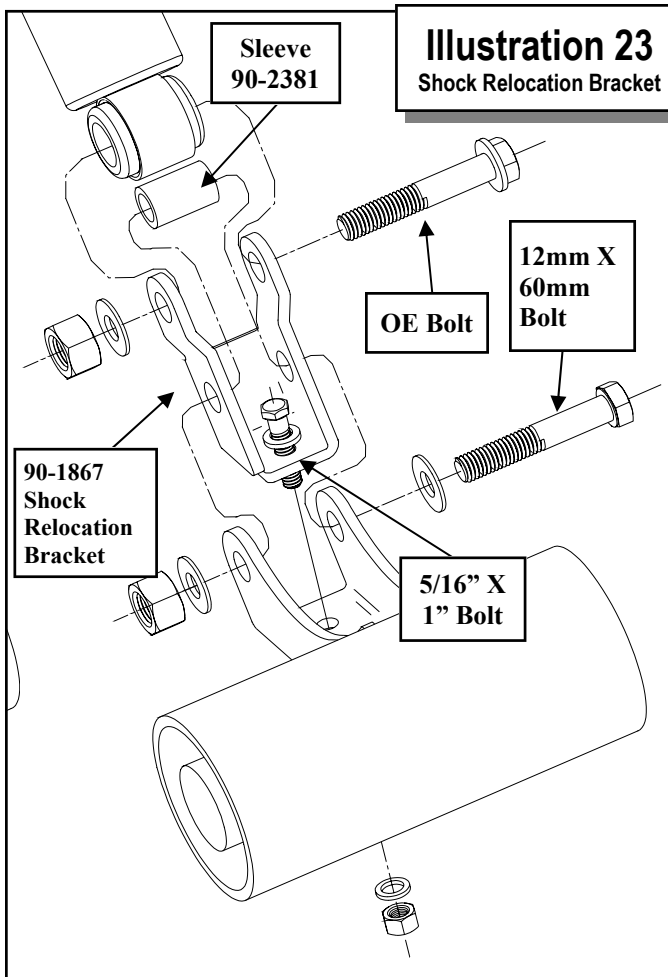
120. Position new rear coil spring (55498) on axle pad. Reinstall coil spring retainer and bolt. Torque to 16 ft./lbs. Raise the rear axle into position until coil spring seats in upper mount.

#### **REAR SHOCKS:**

121. Using the supplied 12mm X 60mm bolt and hardware, install the rear shock relocation bracket (90-1867) to the rear axle. See ILLUSTRATION 23.

122. Install the supplied 5/16" X 1" bolt and hardware from pack (90-6476) to the bracket. The bolt head should be facing up. See ILLUSTRATION 23.

123. Install the new longer shock absorbers (323509 or 923509 or MX6106). Secure the upper shock mount using the previously removed OE hardware. Secure the lower mount to the relocation bracket (90-1867) using the previously removed OE hardware. Torque the shock mount hardware according to the torque chart on page 23 or manufacturers specifications.



### **REAR SWAY BAR END LINKS:**

124. Assemble sway bar links **90-2009** using **60001** bushing and install as shown in ILLUSTRATION 24. Bolt the sway bar end links to the frame and sway bar using the previously removed OE bolts and hardware. Torque the sway bar end link hardware to 40 ft./lbs.

125. Check the suspension and driveline systems for proper operation, tightness and adequate clearance. Recheck brake hose/fitting for leaks. Be sure all hoses are long enough.

126. Install the wheels and tires. Remove the jack stands and lower the vehicle.

### **CHECKS AND ADJUSTMENTS:**

⇒ **Recheck all hardware for tightness after the first 100 miles.**

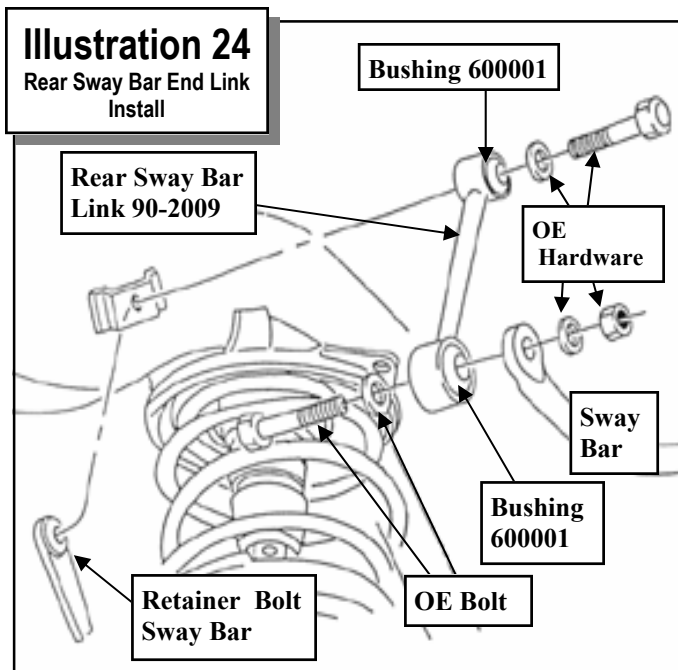
⇒ **To adjust location of front axle (side to side), place vehicle on a flat surface. With the vehicle fully on the ground and the driver side of the track bar NOT attached, center the front differential to the vehicle chassis by measuring the clearance between each tire and inner fender. This is easier done with assistance. Have your assistant sit in the drivers seat and turn the steering wheel slightly from side to side until the axle is centered. When the axle is centered, make sure your assistant holds the steering wheel in position and screw the rod end in or out until the 1/2" X 2" bolt fits through the hole and the rod end without moving the axle. Install the bolt, washers and nut. Torque the bolt according to the chart on page 23.**

⇒ **Steering stops can be adjusted by use of spacers behind welded jam nuts, or be use of a secondary jam nut (not provided).**

⇒ **Headlights should be adjusted.**

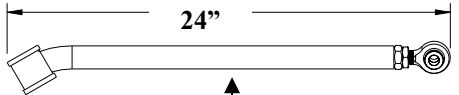
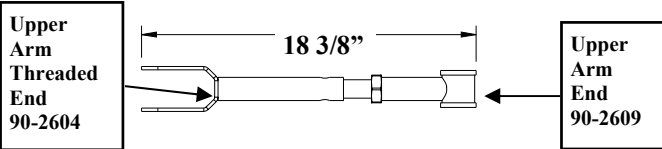
⇒ **A professional alignment using a 4 wheel alignment machine will be necessary after the kit is installed and the final adjustments to the arms and track bar are made.**

⇒ **The exhaust system may need to be altered from the rear of the muffler back by a qualified exhaust shop.**



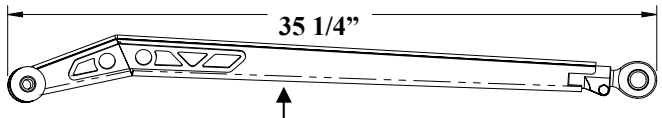
# SUGGESTED CONTROL ARM/TRACK BAR MEASUREMENT CHART

## Front Upper Arms

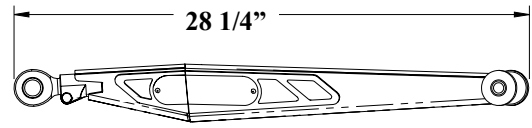


Upper Rear Control Arm 90-2673

## Lower Arms:

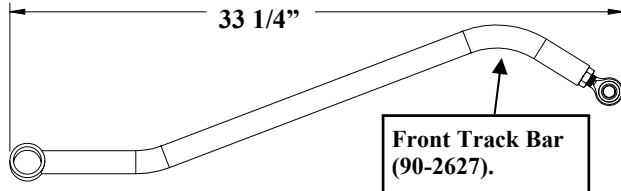


Rear Lower Control Arm 90-3802 drvr 90-3796 pass



Front Lower Control Arm 90-3783 drvr 90-3789 pass

## Front Track Bar



Use this only as a guide for hardware without a called out torque specification in the instruction manual.

<b>Bolt Torque and ID</b>						
<b>Decimal System</b>			<b>Metric System</b>			
All Torques in Ft. Lbs. Maximums						
Bolt Size	Grade 5	Grade 8	Bolt Size	Class 9.8	Class 10.9	Class 12.9
5/16	15	20	M6	5	9	12
3/8	30	45	M8	18	23	27
7/16	45	60	M10	32	45	50
1/2	65	90	M12	55	75	90
9/16	95	130	M14	85	120	145
5/8	135	175	M16	130	165	210
3/4	185	280	M18	170	240	290

1/2-13x1.75 HHCS      **Grade 5    Grade 8**  
 (No. of Marks + 2)

D T L X

G = Grade (Bolt Strength)  
 D = Nominal Diameter (Inches)  
 T = Thread Count (Threads per Inch)  
 L = Length (Inches)  
 X = Description (Hex Head Cap Screw)

M12-1.25x50 HHCS

D T L X

P = Property Class (Bolt Strength)  
 D = Nominal Diameter (Millimeters)  
 T = Thread Pitch (Thread Width, mm)  
 L = Length (Millimeters)  
 X = Description (Hex Head Cap Screw)

### **Notice to Owner operator, Dealer and Installer:**

Vehicles that have been enhanced for off-road performance often have unique handling characteristics due to the higher center of gravity and larger tires. This vehicle may handle, react and stop differently than many passenger cars or unmodified vehicles, both on and off-road. You must drive your vehicle safely! Extreme care should always be taken to prevent vehicle rollover or loss of control, which can result in serious injury or even death. Always avoid sudden sharp turns or abrupt maneuvers and allow more time and distance for braking! Pro Comp reminds you to fasten your seat belts at all times and reduce speed! We will gladly answer any questions concerning the design, function, maintenance and correct use of our products.

### **Please make sure your Dealer/Installer explains and delivers all warning notices, warranty forms and instruction sheets included with Pro Comp product.**

Application listings in this catalog have been carefully fit checked for each model and year denoted. However, Pro Comp reserves the right to update as necessary, without notice, and will not be held responsible for misprints, changes or variations made by vehicle manufacturers. Please call when in question regarding new model year, vehicles not listed by specific body or chassis styles or vehicles not originally distributed in the USA.

**Please note that certain mechanical aspects of any suspension lift product may accelerate ordinary wear of original equipment components.** Further, installation of certain Pro Comp products may void the vehicle's factory warranty as it pertains to certain covered parts; it is the consumer's responsibility to check with their local dealer for warranty coverage before installation of the lift.

### **Warranty and Return policy:**

Pro Comp warrants its full line of products to be free from defects in workmanship and materials. Pro Comp's obligation under this warranty is limited to repair or replacement, at Pro Comp's option, of the defective product. Any and all costs of removal, installation, freight or incidental or consequential damages are expressly excluded from this warranty. Pro Comp is not responsible for damages and / or warranty of other vehicle parts related or non-related to the installation of Pro Comp product. A consumer who makes the decision to modify his vehicle with aftermarket components of any kind will assume all risk and responsibility for potential damages incurred as a result of their chosen modifications. Warranty coverage does not include consumer opinions regarding ride comfort, fitment and design. Warranty claims can be made directly with Pro Comp or at any factory authorized Pro Comp dealer.

**IMPORTANT!** To validate the warranty on this purchase please be sure to mail in the warranty card.

### **Claims not covered under warranty-**

- Parts subject to normal wear, this includes bushings, bump stops, ball joints, tie rod ends and heim joints
  - Discontinued products at Pro Comp's discretion
- Bent or dented product
- Finish after 90 days
- Leaf or coil springs used without proper bump stops
- Light bulbs
- Products with evident damage caused by abrasion or contact with other items
- Damage caused as a result of not following recommendations or requirements called out in the installation manuals
- Products used in applications other than listed in Pro Comp's catalog
- Components or accessories used in conjunction with other manufacturer's systems
- Tire & Wheel Warranty as per Pro Competition Tire Company policy
- Warranty claims without "Proof of Purchase"
- Pro Comp Pro Runner coil over shocks are considered a serviceable shock with a one-year warranty against leakage only. Rebuild service and replacement parts will be available and sold separately by Pro Comp. Contact Pro Comp for specific service charges.
- Pro Comp accepts no responsibility for any altered product, improper installation, lack of or improper maintenance, or improper use of our products.

**E-Mail: [tech@explorerprocomp.com](mailto:tech@explorerprocomp.com)**  
**Website: [www.explorerprocomp.com](http://www.explorerprocomp.com)**  
**Fax: (619) 216-1474**  
**Ph: (619) 216-1444**

<b><u>PLACE</u></b>
<b><u>WARRANTY REGISTRATION</u></b>
<b><u>NUMBER</u></b>
<b>HERE:</b> _____