



2012 + JEEP JK INTERCOOLED SUPERCHARGER SYSTEM

TO SUIT PENTASTAR 3.6L V6



INSTALLATION INSTRUCTIONS 263D1001

TABLE OF CONTENTS

INTELLECTUAL PROPERTY USED IN THIS PUBLICATION	4
IMPORTANT INFORMATION / PRODUCT WARNING	5
CHANGES TO FACTORY SPECIFICATIONS	6
SERVICING REQUIREMENTS: See maintenance section of this manual	6
TOOLS AND CONSUMABLES REQUIRED TO COMPLETE INSTALLATION.....	6
PARTS SUPPLIED.....	7
DISASSEMBLY INSTRUCTIONS.....	10
PREPERATION.....	10
1. Fuel System Pressure Relief	12
2. Remove the front bumper.	13
3. Remove the grille.	13
4. Drain cooling system.	14
5. Intake manifold removal.....	14
6. Disengage and reposition the following hoses from the upper intake manifold:.....	16
7. Remove the heater coolant tube assembly.	16
8. Remove the fuel rails and injectors.	18
9. Remove the alternator and mounting bracket.	20
10. Modify the wiring harness.	21
11. Modify the automatic transmission dipstick tube.	23
12. Modify the hood lining	24
13. Install engine breather hoses.....	26
14. Install heater hoses.....	27
15. Install the water pump bracket.	28
16. Install the Intercooler hoses.	28
17. Install the radiator mount brackets and radiator.	29
18. Install the lower supercharger manifold.....	30
19. Install the upper supercharger manifold.	31
20. Tighten the upper manifold	32
21. Install the idler pulley bracket.....	33
22. Install the drive belt.....	34
23. Install the throttle body.....	35
24. Install the MAP sensor.....	35
25. Attach engine breather hose.....	35



26. Attach intercooler hoses	36
27. Install the purge solenoid hose	36
28. Install the air box	36
29. Install the clean air duct	37
30. Attach vacuum hose	37
31. Secure hoses.....	38
32. Connect battery	38
33. Fill intercooler system and vehicle cooling system.....	38
34. Attach the radiator grille	39
35. Re-install the bumper and splash guard.....	39
36. Load the ECM re-flash.....	39
37. Pre start inspection	41
38. Engine warm up.....	41
39. Check and adjust supercharger pulley alignment.....	41
40. Road test	41
41. Supercharger belt replacement.....	43
42. Supercharger gear case oil change interval.....	43
43. Supercharger gear case oil change procedure	43



INTELLECTUAL PROPERTY USED IN THIS PUBLICATION

This document is copyright of Sprintex Ltd, a company incorporated in Australia. This document may not be re-sold, copied or distributed in any way without prior written authorisation of Sprintex Ltd.

Copyrights / Trademarks:

Sprintex® is a registered trademark of Sprintex Limited, an Australian company ACN: 106 337 599 (“Sprintex”). Sprintex has patents for its superchargers. Any unauthorised copying or modification of the system may result in legal action.

Loctite® and Grey Maxx® are registered trademarks of Henkel KGaA, a company incorporated in Germany. Other than commercial supply arrangements, Henkel KGaA does not have any association with Sprintex.

RedLine® is a registered trademark of RedLine Synthetic Oil Corporation, a company incorporated in the United States of America. Other than commercial supply arrangements, Redline and RedLine Synthetic Oil Corporation do not have any association with Sprintex.

Jeep, Jeep JK, Jeep Wrangler are registered trademarks of Chrysler Group LLC, a company Headquartered in Auburn Hills, MI, USA.
(<http://www.chryslergroupllc.com>)

SAE is a trademark of SAE International (www.sae.org) an international technology, information and standards setting resource organisation for the design, manufacturing, operation, and maintenance industry.

Gates is a registered trademark of the Gates Rubber Company, a subsidiary of Tomkins PLC, incorporated in London, United Kingdom. Other than commercial supply arrangements, Gates and Tomkins PLC do not have any association with Sprintex Limited.

IMPORTANT INFORMATION / PRODUCT WARNING

Installation of the Sprintex Supercharger system on a Pentastar 3.6L V6 Jeep - JK vehicle may void all or parts of the Jeep Warranty. Customers should consult their Jeep dealer for details.

Sprintex makes no representation that installation and use of the Sprintex supercharger system is legal for public road use worldwide. Customers should check that installation and use of the Sprintex supercharger system on their vehicle is legal by contacting the relevant statutory authority in their jurisdiction prior to use on public roads.

Provided in this installation manual are detailed instructions to the installer on how to install the Sprintex patent pending supercharger system to the Jeep- JK vehicle. The instructions are aimed at being simple yet informative, and are aided with well-presented pictures to make installations as simple, fast, and problem free as possible. Please read the entire instruction manual prior to beginning the installation procedure. Pictures and descriptions may vary slightly from model to model.

It is recommended that all wiring harness connectors, and vacuum hoses are labelled at the time of removal for easy and correct refitting. Some components that are removed and are to be refitted are fragile, and should be stored safely to prevent damage to these components.

- Sprintex recommends performing the following vehicle checks prior to installing the supercharger:
- Check that the factory fuel system is operating correctly.
- Ensure that the vehicles ignition system is working correctly.
- Install new standard spark plugs and set gap to 0.043" / 1.1mm.
- Inspect the catalytic converters for blocks or damage.
- Replace the fuel filter if the vehicle has travelled more than 15,000 Km or 9000 miles.

It is recommended to run at least one full tank of premium unleaded fuel through the vehicle prior to installing the supercharger system to prevent any possible damage that may occur due to running the supercharged engine on lower octane fuel.

Sprintex will not be liable for any loss, damage, payment, costs, expenses or other liability, not expressly stated in this document. In particular, Sprintex shall not be liable to any person for any consequential, indirect or economic loss or punitive or exemplary damages of any kind.

Sprintex reserves the right to change specifications from time to time and will not be liable to any person or entity for doing so. Sprintex believes that information in this document is correct at time of print. Sprintex limits its liability to the maximum extent permissible at law with regard to the reliance which any person places on anything in this document.

This Sprintex installation requires that the vehicle be equipped with a standard Jeep-JK factory ECU and calibration. Failure to ensure this will affect the performance and may void warranty.



CHANGES TO FACTORY SPECIFICATIONS

FUEL: Minimum 95 RON (91 Octane USA) premium unleaded gasoline / fuel to be used at all times. Never allow the engine to knock or detonate as serious engine damage may occur.

SERVICING REQUIREMENTS: See maintenance section of this manual.

Inspect supercharger drive belt at every routine service and replace when required.

Drain and replace supercharger oil every 50,000 km or 30,000 miles. Use Redline 75W90 NS gear oil or equivalent. It is critical not to overfill supercharger gearbox as damage will occur. **Fill with exactly 60 millilitres or 2.03 US fluid ounces and check the oil level with the dipstick provided.**

NOTE:

Many of the photos shown in this document are of a typical Jeep-JK right hand drive vehicle and are similar to a typical Jeep-JK left hand drive vehicle.

Some of the terminology and language used in this instruction may vary from that of the end user / installer's expectations, as some tools and automotive components have different common names in different geographical locations.

TOOLS AND CONSUMABLES REQUIRED TO COMPLETE INSTALLATION

- Metric & inch spanners (wrenches) and sockets
- Flat blade & Philips screwdrivers
- Cloth tape (race tape or 100MPH tape)
- Trim clip removal tool
- Pliers & side cutters (dykes)
- ½" Breaker bar
- Hose clamp pliers
- Rubber grease or white petroleum jelly
- Metric Allen keys
- Electrical tape
- Torque wrench

PARTS SUPPLIED

Lower Supercharger Manifold



Upper Supercharger Manifold with pulley



Idler Bracket Assembly



Heater hose "A"



Heater hose "B"



Heater hose "C"



Engine breather hose "A"



Engine breather hose "B"



Engine breather hose "C"



Intercooler hose "A"



Intercooler hose "B"



Intercooler hose "C"



Water Pump & Bracket



W/Pump Wiring Harness



Intercooler Radiator



Radiator mount brackets (X3)



6PK2635 (K061037) drive belt



Fuel Injectors (X6)



M6 Manifold Studs (x7)



M6 Nyloc Nuts (x7)



26mm springband clamps (x14)



24mm springband clamp (x4)



Purge solenoid hose assembly



Diablo SP1000 flash tuner



M6 x 30 Flange head screw
(x10)



M6 x 25 Flange head screw BLK
(x4) These screws are located in
the lower plate of the manifold
assembly.



MAP sensor adaptor loom



Throttle body extension loom



M6 x 90 (x1) M6 x 100 (x1) Hex
head screws + 6mm x 17mm x
3mm Washers (x2)



Inlet duct



MAP sensor



Pulley



Self-tapping screw



¼ BSPP plug



M8 x 16 flange head screw (x2)



M6 x 20 flange head screw (x2)



PENTASTAR 3.6L V6 JEEP JK SUPERCHARGER SYSTEM

SECTION 1

DISASSEMBLY INSTRUCTIONS

PREPERATION

Ensure that all components required to install the supercharger system are available, refer to the Parts Supplied section provided earlier.

Ensure that all required tools are available.

Please read the entire installation manual prior to beginning the installation procedure.

Ensure the vehicle is located in a secure position with vehicle tyres secured and hand brake applied.

To avoid injury, Sprintex® recommends the use of a suitable vehicle lift or appropriate safety stands when the vehicle is required to be lifted. Stands should be positioned as per the vehicle manufacturer's owner's handbook.

SAFETY WARNING

No unauthorised service or alteration may be undertaken to the Sprintex supercharger. Installation should be carried out in a workshop which is a safe and ventilated working environment with equipment and procedures compliant with local authority guidelines and legal requirements. Installers should ensure adequate hearing, eye, and physical protection is used at all times during the installation process. Installers should take reasonable precautions to avoid fatigue and closely follow the installation instructions during every installation. Sprintex recommends installation should not be carried out unsupervised. Sprintex, its directors, employees and agents will not accept liability for damage accident or injury resulting from the installation process. Safety warnings are also provided throughout this document.

Allow engine to cool prior to proceeding with disassembly to prevent scalding.

NOTES:

- During disassembly and removal of components, take notes and ensure parts are labelled and stored safely; this will help with the reassembly.
- Many of the photos shown in this document are of a typical Jeep- JK right hand drive vehicle and are similar to a typical Jeep- JK left hand drive vehicle.



LHD VEHICLE



RHD VEHICLE

- Connect and disconnect battery cables, jumper cables or battery charger only with the ignition off.
- Disconnecting the battery may erase fault codes stored in control module memory. Using diagnostic equipment, check for fault codes before disconnecting battery cables. If the malfunction indicator light (MIL) is illuminated.
- **MIL (Malfunction Indicator Lamp) light.**
The MIL light can be found in one of two locations, dependant on the market the vehicle has been built for.
The MIL light may be an illuminated ENGINE symbol within the instrument cluster.
Please refer to the Jeep owner's handbook to define which off the above applies to the vehicle to be fitted with the Sprintex unit.
- Always disconnect the negative battery terminal first. This prevents possible shorting and potential battery damage.

1. Fuel System Pressure Relief

- Remove the fuel fill cap.
- Remove the fuel pump fuse (M37, 10A fuse labelled ABS, FUEL PUMP RELAY, SWAY BAR) from the Power Distribution Centre (PDC). For location of the fuel pump fuse, refer to label on the underside of the PDC cover
- Start and run the engine until it stalls.
- Attempt restarting the engine until it will no longer run.
- Turn the ignition key to the OFF position.
- Disconnect and isolate the negative (“-“) battery terminal.
- Re-install the fuse.

2. Remove the front bumper.

- Remove the push pin fasteners (2) and release the splash shield (1) from the bumper.

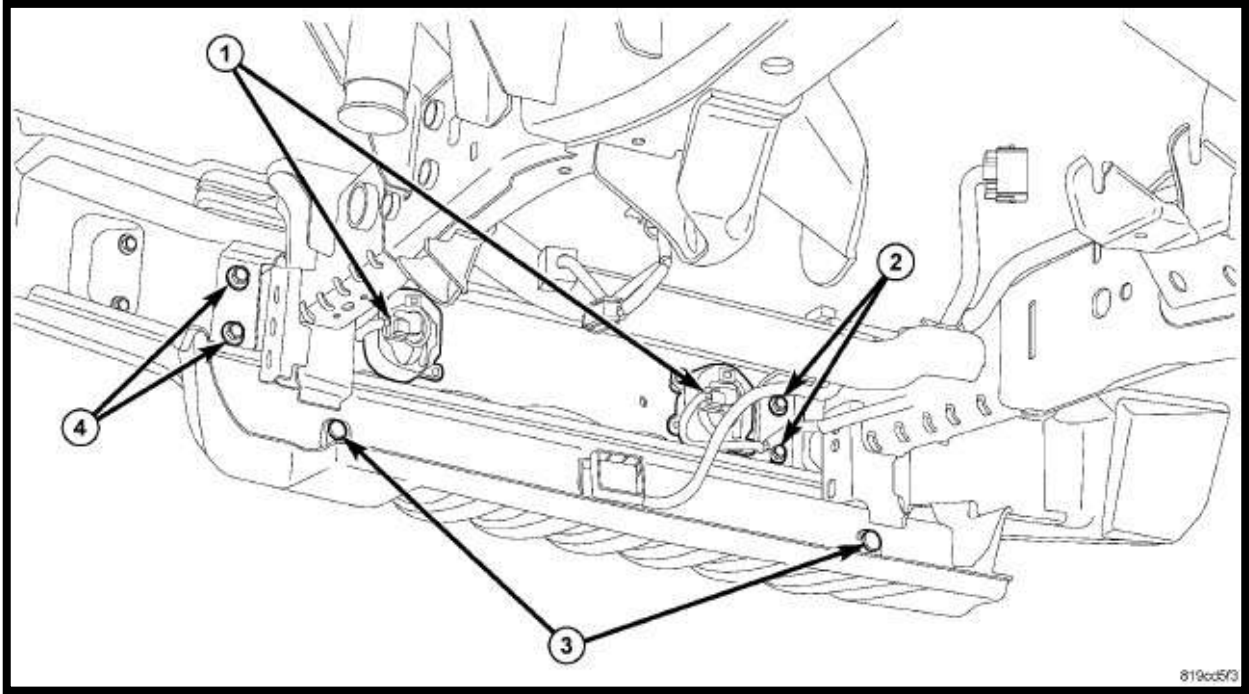

- Remove the push pin fasteners (3) and remove the splash shield.
- Disconnect the electrical connectors (1).
- Remove the outer (4) and inner support bolts (2) and remove the front bumper.

3. Remove the grille.

- Twist the centre of the push pin insert to release and remove the six push pin fasteners (1)
- Release the lower clips (3) and separate the grille from the front end module.
- Disconnect the electrical connectors (4).

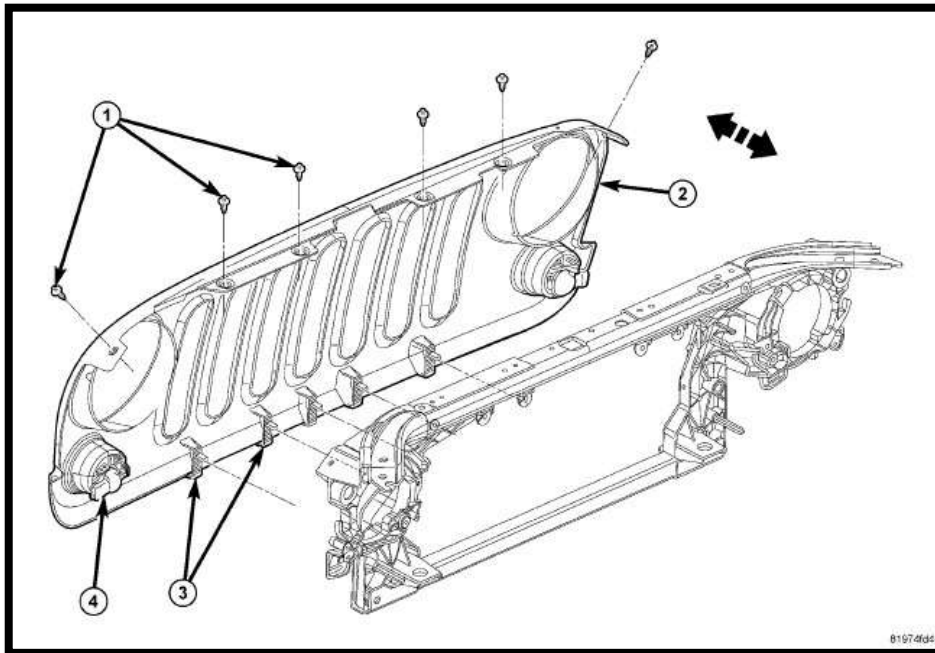

4. Drain cooling system.

NOTE: Radiator drain valve is located on the right/lower side of radiator facing to front of vehicle.

- Remove radiator pressure cap from radiator or coolant recovery container as necessary.
- Attach one end of a hose to the drain valve. Put the other end into a clean container. Open valve and drain coolant from radiator.

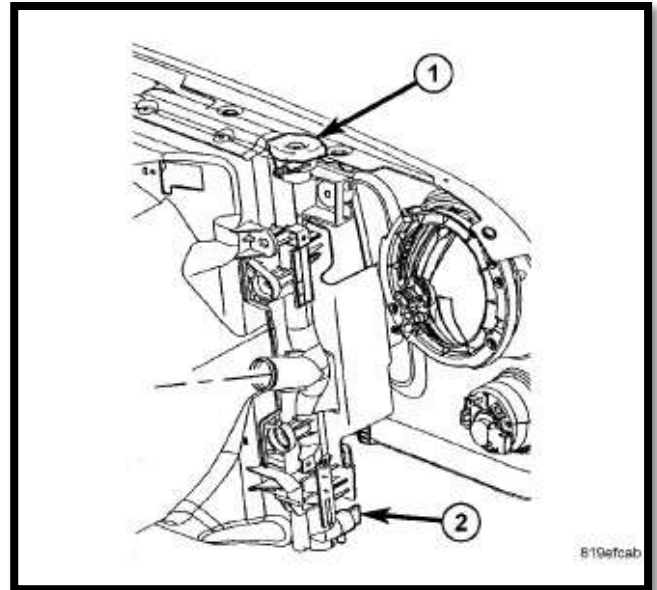

5. Intake manifold removal.

- Remove the engine cover (1).
- Disconnect the electrical connector (3) from the Inlet air temperature (IAT) sensor, remove the sensor from the inlet pipe and set it aside to use later.
- Loosen the clamp (4) at the throttle body.
- Disconnect the fresh air makeup hose (2) from the air cleaner body.
- Disengage the coolant hose from the two retainers (6).
- Remove the two bolts (5) from the air inlet hose.
- Disengage the air inlet hose from the throttle body and pull the air cleaner body (1) straight up off of the three locating pins.

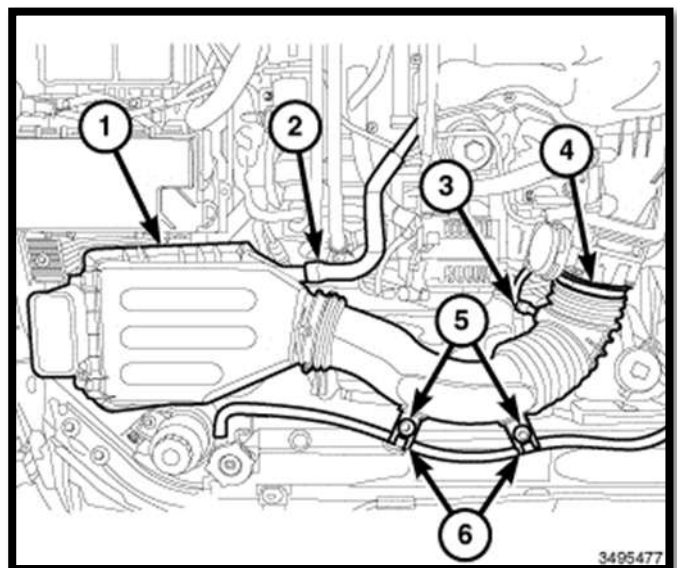
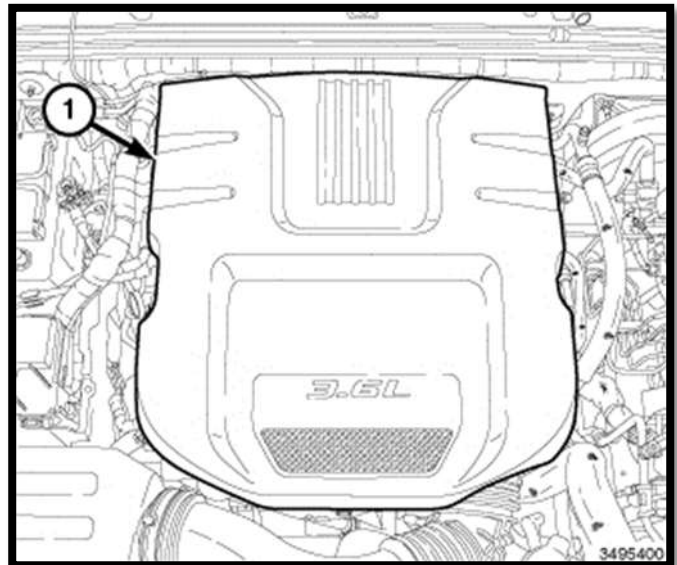

- Disconnect the electrical connectors from the Manifold Absolute Pressure (MAP) sensor (1) and the Electronic Throttle Control (ETC) (6).
- Disengage the ETC harness from the clip (5) on the throttle body.
- Disengage the wire harness retainer (2) from the upper intake manifold.
- Disengage the wire harness retainers (3 and 4) from the left front upper intake manifold support bracket and reposition the wire harness.

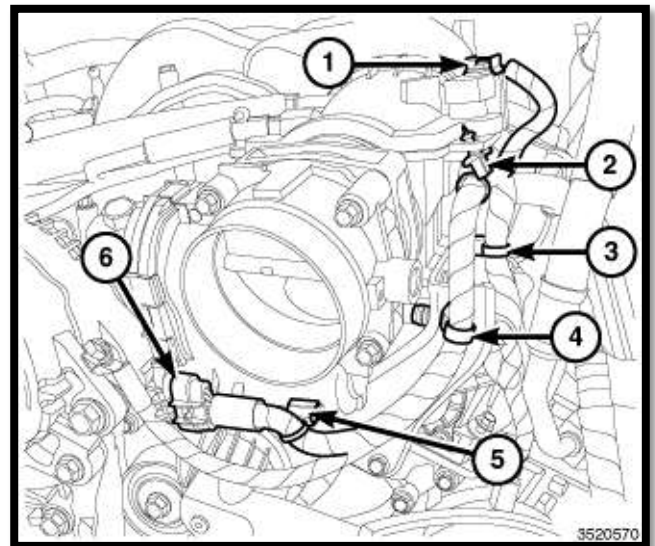

- Disconnect the following hoses from the upper intake manifold:
 - Positive Crankcase Ventilation (PCV) (1)
 - Fuel vapour purge (3)
 - Brake booster (2)

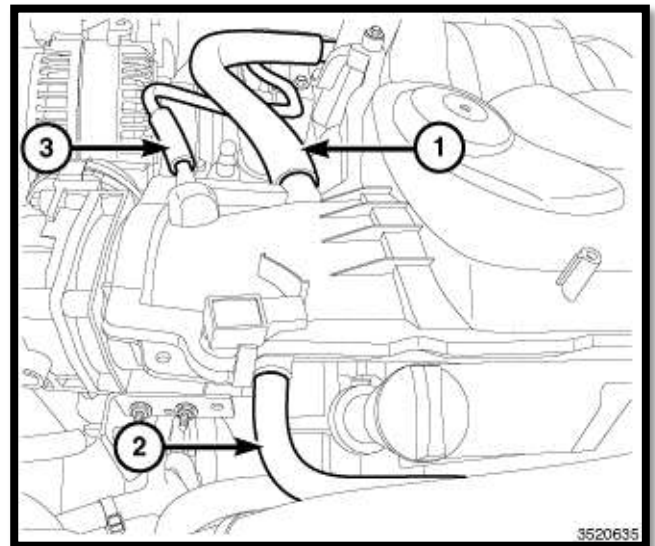

- Remove two nuts (2), two bolts (3) and the left front upper intake manifold support bracket (1).

Note: this bracket will not be used for the supercharger install, store it along with the other OEM components.

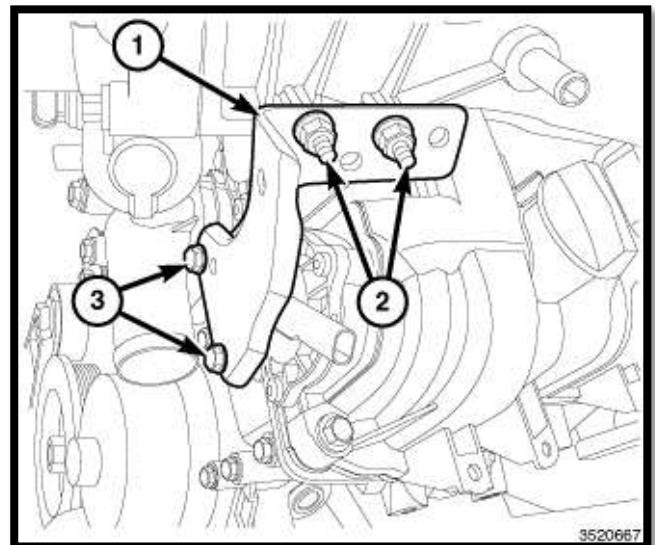

- Remove two nuts (2) from the left rear upper intake manifold support bracket (1)
- Loosen two stud bolts (3) and reposition the left rear upper intake manifold support bracket (1) away from the upper intake manifold.

Note: Installing the upper manifold assembly is easier with this bracket removed and re-fitted subsequently.

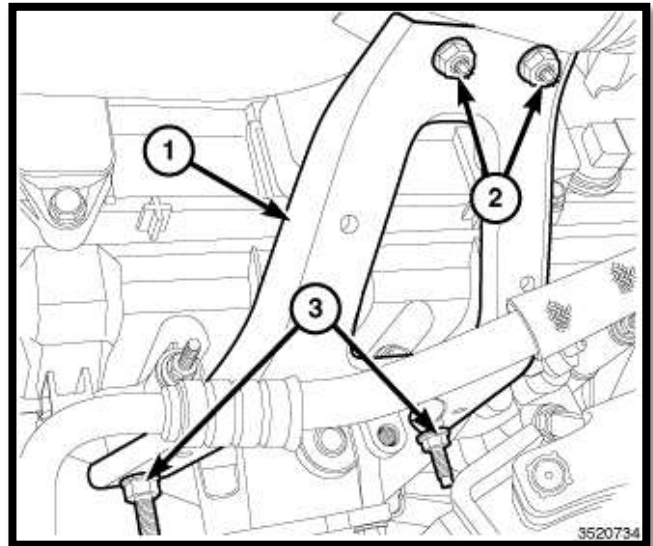

6. Disengage and reposition the following hoses from the upper intake manifold:

- Transfer case vent (3)
- Positive crankcase ventilation (PCV) (5)
- Fresh air make up.(4)
- Disengage the wire harness connector retainer (2) from the right upper intake manifold support bracket.
- Disengage two purge tube retainers (6) from the right side upper intake manifold support bracket.
- Remove two nuts (7).

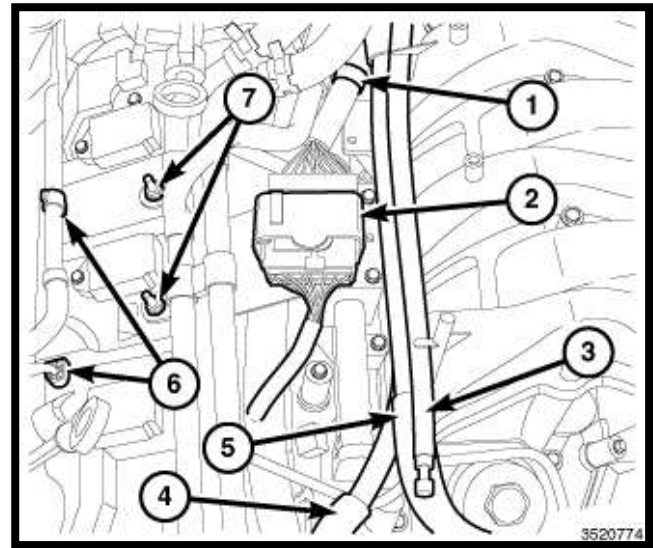

7. Remove the heater coolant tube assembly.

- Remove the heater core supply hose (1) from the heater core tube assembly.
- Remove the heater core return hose (2) from the heater core tube assembly.

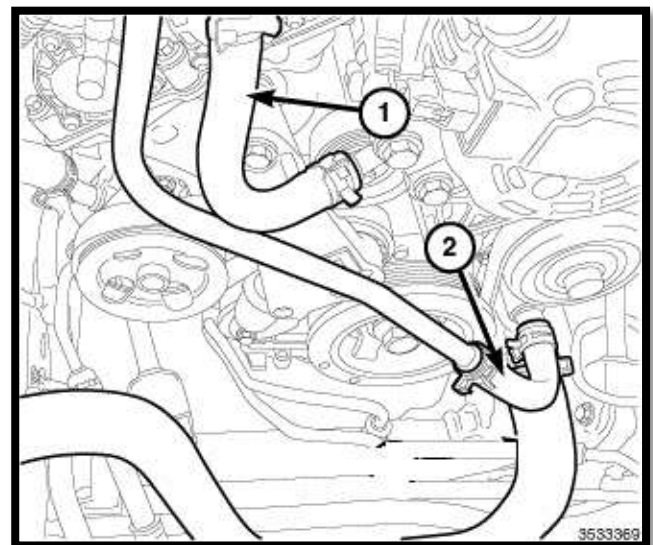

- Remove the heater core supply hose (2), heater core return hose (1) and oil cooler return hose (4) from the heater core tube assembly.
- Remove two nuts (3) and the heater core tube assembly from the right upper intake manifold support bracket.

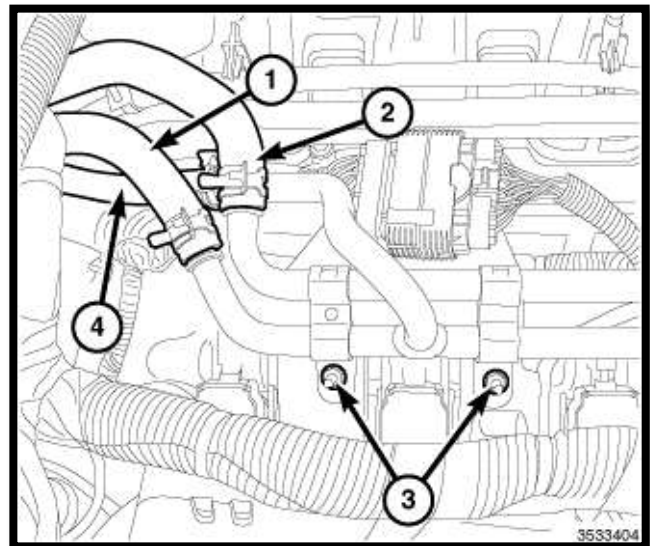

NOTE: Heater coolant tube assembly not shown for clarity

- Remove two bolts (2) from the right upper intake manifold support bracket (1)
- Remove two nuts (3) and the right upper intake manifold support bracket (1).

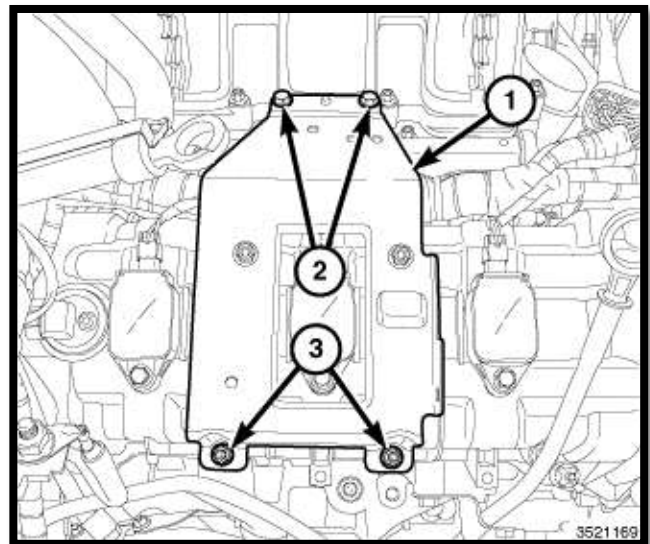

NOTE: The upper intake manifold attaching bolts are captured in the upper intake manifold. Once loosened, the bolts will have to be lifted out of the lower intake manifold and held while removing the upper intake manifold.

- Remove seven upper intake manifold attaching bolts (1) and remove the upper intake manifold (2).
- Cover the open intake ports to prevent debris from entering the engine.

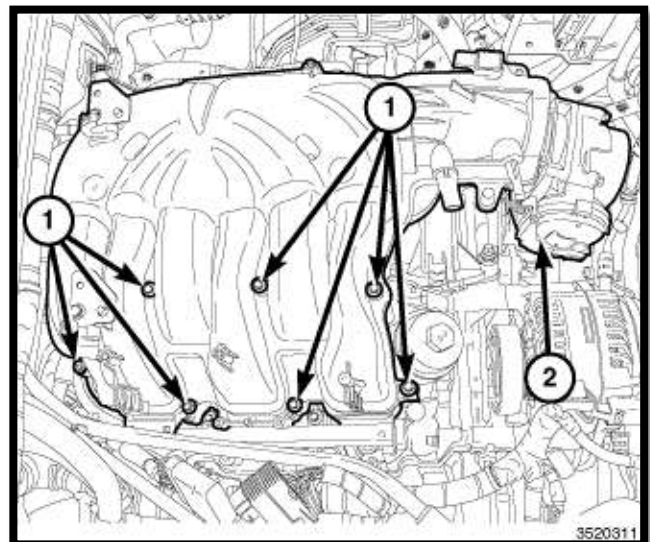

8. Remove the fuel rails and injectors.

- Disconnect the fuel injector electrical connectors (1.)
- Place a rag under the fuel rail supply line quick connector to catch any residual fuel while disconnecting the fuel supply hose (2) from the fuel rail.

Note: Fuel may escape under pressure when any fuel hose is disconnected. Take care to avoid contact with the skin or eyes. Ensure that no ignition source is close by to prevent the risk of fire.

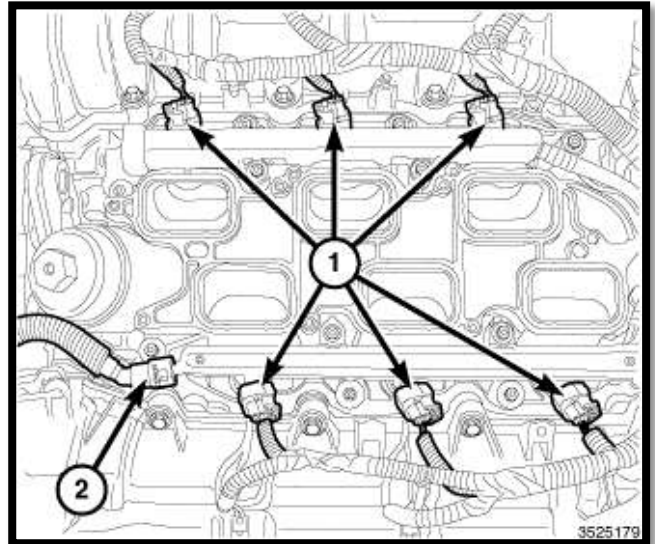

- Disconnect the fuel supply line quick-connect fitting at the fuel supply line.
- This type of quick-connect fitting is equipped with a redundant latch (2) and a single push button (1) that releases two internal latches located in the quick-connect fitting. Special tools are not required for removal.

CAUTION: Do not pry or pull up on the push button as damage to the latches of the quick-connect fitting will occur.

- Pull the redundant latch (2) out away from the quick-connect fitting.
- Press on the push button to release the internal latches (1) and remove the quick-connect fitting from the fuel system component.

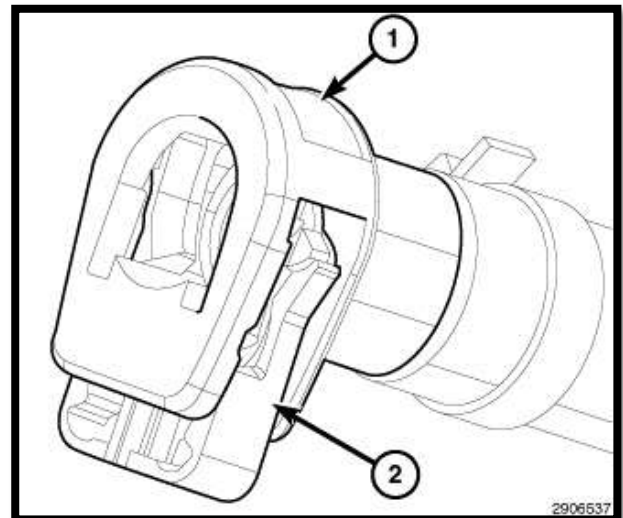
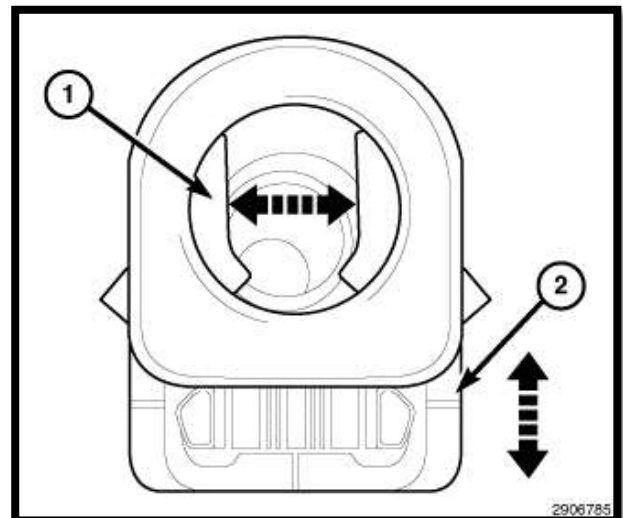

- Remove the four bolts (1) from the fuel rail (2).

CAUTION: When removing the fuel rail from the lower intake manifold, one or more fuel injectors may remain in the intake manifold resulting in residual fuel spilling out onto the engine from the fuel rail.

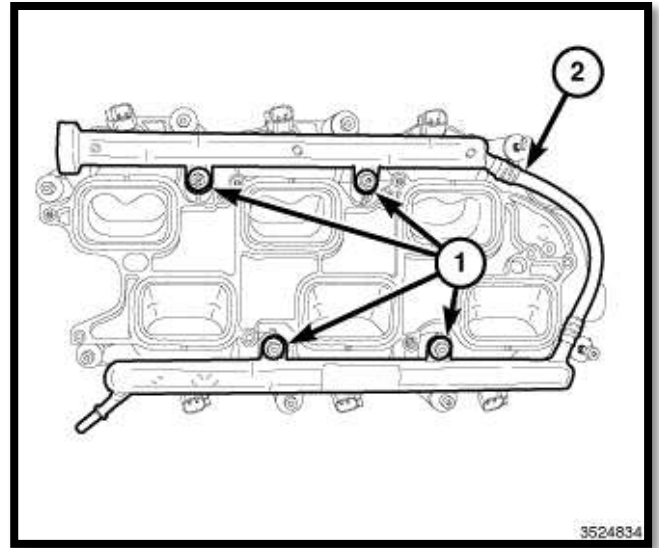

- Remove the remaining fuel injectors (1) from the fuel rail (2).
- Remove the remaining fuel injectors (1) from the lower intake manifold.
- Lubricate the o-rings of the injectors supplied with the system with rubber grease or white petroleum jelly prior to replacing the OEM injectors. Take care when installing the injectors into the fuel rail to prevent damage to the o-ring.
- Re-attach the fuel rail with the OEM fasteners and tighten to 7Nm.
- Re-connect and lock the fuel injector electrical connectors.
- Lubricate the fuel rail spigot with rubber grease or white petroleum jelly before reconnecting the fuel rail supply line quick connector.
- Lock the connector.

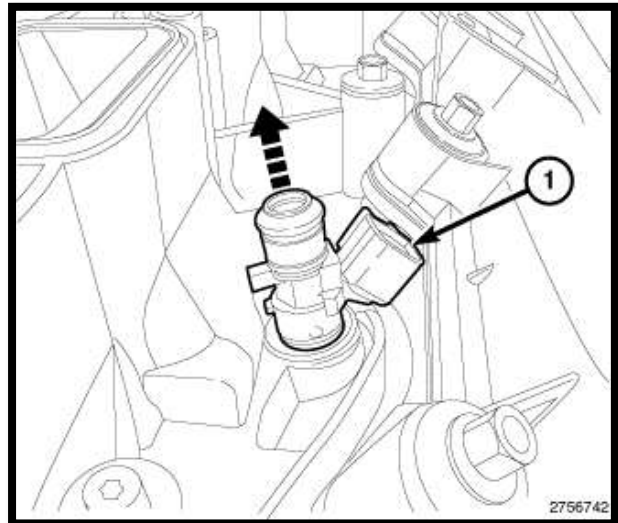
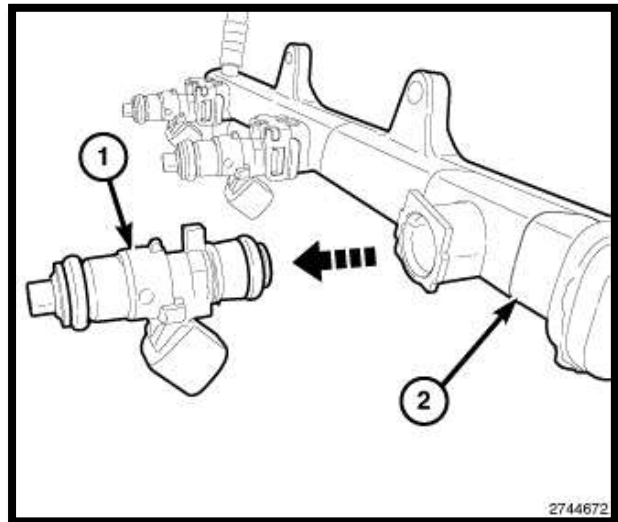

9. Remove the alternator and mounting bracket.

- Remove the alternator electrical connector (2) and the B+ battery stud cover (1)
- Remove the B+ retainer (1) and position aside the B+ cable.
- Remove the alternator and mount via the 2 bolts either side of the alternator and the 2 lower screws in the lower section of the alternator mount bracket.
- Remove the factory drive belt and replace with the belt supplied with the supercharger system.

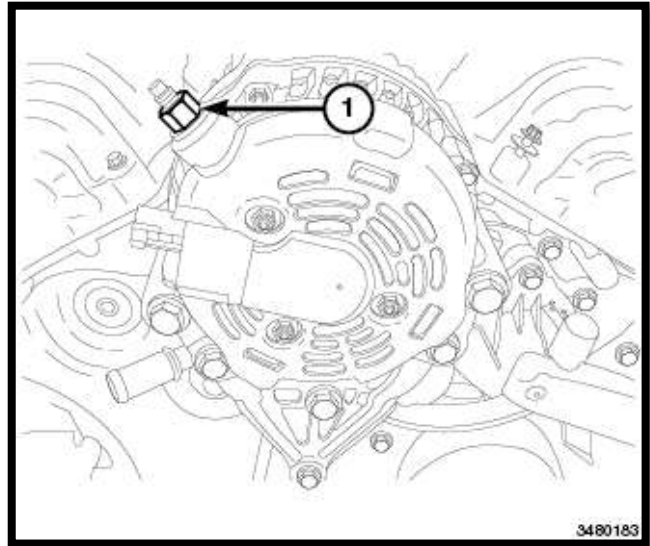
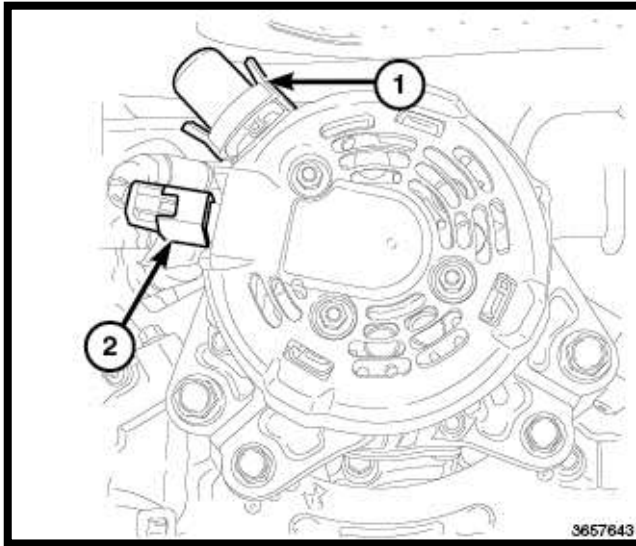

10. Modify the wiring harness.

- Remove the harness retainers from the valve cover.
- Disconnect the grey harness connector.
- Carefully strip back the OEM harness until there is sufficient length available in the break-out wire to allow the grey plug to reach the back of the engine. Fold back the wiring and tape into place.
- Re-attach the protective sleeving and neatly tape into place.
- Attach the harness to the valve cover using the cable ties supplied.



- Remove the grey harness retainers from the valve cover and harness on the left bank, neatly tuck the harness down beside the fuel rail and tie in place with the cable ties supplied.
- At this stage connect the water pump wiring harness to the injector connector of cylinder #2 and run the wire down beside the radiator. Tie in place with cable ties supplied.



11. Modify the automatic transmission dipstick tube.

(Not required for manual transmission)

- Remove the 2 bolts retaining the tube, one at the rear of the engine block and the other at the transmission. Remove the transmission dipstick tube. (See Images)
- Measure 135mm from the top of the dipstick tube and mark the tube, then cut the tube square along the mark.
- Clean edges and remove burrs.
- Rotate the end of the tube 180°.
- Join the 2 sections of tube with the section of rubber hose and 2 hose clamps provided, making sure to push both ends together prior to tightening the hose clamps.
- Re install the dip stick tube



12. Modify the hood lining.

- Remove the hood lining
- Using the template supplied on the last page of this document, trace around the template and cut out area with a sharp pair of scissors.
- Re-attach the hood lining.

Note: the reason for the cut out is to prevent the hood lining blocking the air box inlet.



PENTASTAR 3.6L V6 JEEP JK SUPERCHARGER SYSTEM

SECTION 2

INSTALLATION INSTRUCTIONS

13. Install engine breather hoses.

- Modify the vacuum hose routing, carefully separate the 2 ends of the hose at the “T” junction, rotate the “T” piece 180° and re-attach the hose ends as shown in image.
- Remove the engine breather hose from the OEM intake manifold and remove both rubber ends from the rigid plastic line.
- Attach the engine breather hose “B” (5/8” I.D.) to the rigid plastic line (see Image).
- Install the rigid plastic line and attach engine breather hose “B” to the spigot on the back of the RHS valve cover.
- Attach the straight end of engine breather hose “A” to the spigot of the rear of the LHS valve cover.



14. Install heater hoses.

- Install the new heater hose assembly supplied. Neatly route the hoses as shown in the images and connect the hose to the outlet on the engine block with the spring band clamps supplied (see image).
- Install the second heater hose, following the routing of the first hose and attach hose to the other spigot on the cylinder block with the spring band clamps supplied (see image).
- Fix the hoses in place with 2 cable ties supplied.



15. Install the water pump bracket.

- Attach the water pump bracket and pump to the OEM vacuum pump mount behind the front bumper bar. Fasten the bracket in place with the original nuts; also connect the pump connector and the ground connection eyelet.
- Fix the harness in place with the cable ties supplied.



16. Install the Intercooler hoses.

- Attach intercooler hose "A" to the water pump and fix in place with a spring band clamp supplied.
- Install intercooler hose "B". Route the hose through the gap on the upper LHS of the radiator shroud and pass the hose down beside the radiator then back toward the engine.
- Lower intercooler hose "C" down behind the radiator following the OEM radiator hose routing, bring the lower section of the intercooler hose forward and connect the end of the hose to the water pump using the spring band clamp supplied. Fix hoses in place with the cable ties supplied.



17. Install the radiator mount brackets and radiator.

- Feed the radiator mount nut plate into the hood latch hole underneath the radiator support frame. (See image).
- Prior to attaching the upper radiator mount bracket, feed 2 cable ties through the holes in the bracket, attach the bracket to radiator support frame with the M6 X 16mm SHCS and the nut plate, do not tighten until radiator has been installed.
- Attach the lower radiator mount bracket by pushing it onto the lower radiator support frame, making sure that the slots are lined up with the corresponding slots of the radiator support frame.(see image)
- Prior to installing the radiator to the vehicle, install the ¼ BSPP plug into the radiator and tighten to 16Nm. (see lower right image)Then attach the radiator to the upper radiator mount bracket with the M8 X 12mm hex head screws; tighten the upper radiator mount bracket.
- Attach the hoses to the radiator with the spring band clamps supplied and tighten all fasteners and cable tie the hoses in place.

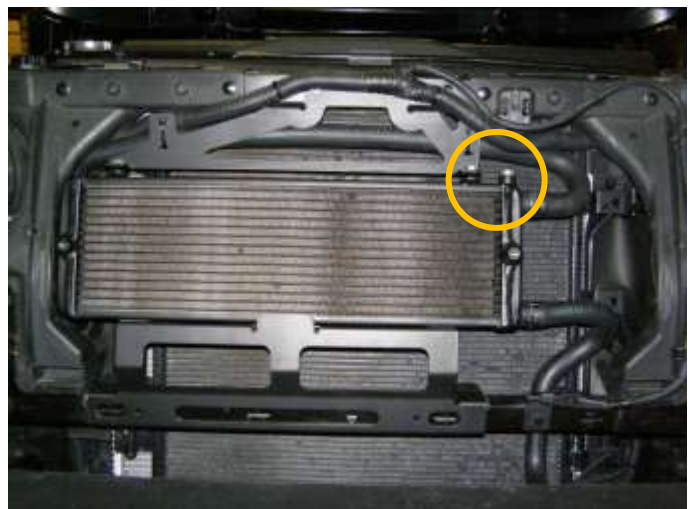
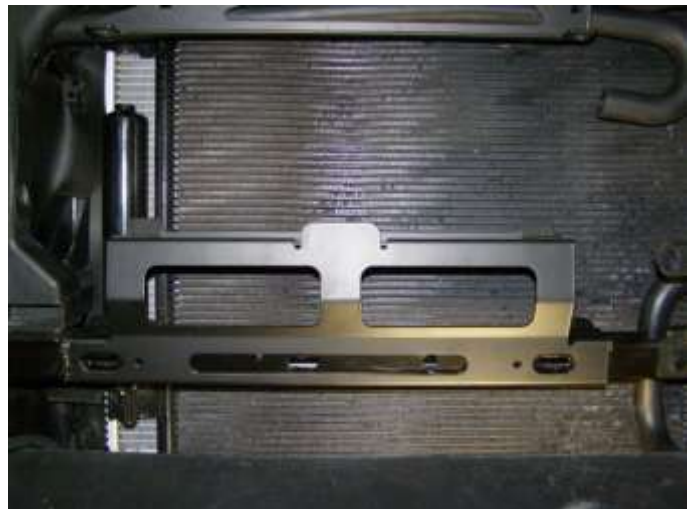

18. Install the lower supercharger manifold.

- Install the 7 manifold studs with a 4mm socket and tighten to 8NM.
- Place the four M6 X 25mm black screws into the lower manifold from the underside (see image). Retain screws in place with M6 Nyloc nuts, finger tighten only.
- Place the lower manifold over the studs & install the M6 Nyloc nuts utilising the four nuts which are retaining the four M6 x 25mm black screws in place.

Take care to not drop any nuts down the intake ports.

- Gently push the lower manifold back towards the bulk head and tighten the nuts to 12Nm.
- Attach the throttle body extension loom and MAP sensor adaptor loom, lay the extension toward the left hand side of the vehicle.



19. Install the upper supercharger manifold.

- Prior to installing the upper assembly apply 3 strips of cloth tape to the bulkhead insulation to prevent damage to it when tightening the rear fasteners on the upper manifold (see image below).
- Install a 1mm shim into the supercharger drive pulley and attach it to the supercharger with the four M6 x 20mm SHCS and tighten to 12Nm.
- Remove cylinder #6 coil.(see Image)
- Place the M6 X 90mm long hex head screw and washer supplied into the upper manifold prior to installation; carefully lower the upper manifold onto the lower manifold.
- With the upper manifold in place, start to tighten the rear screw but do not tighten completely.



20. Tighten the upper manifold

- Place the ten M6 X 30mm flange head screws into the upper manifold and finger tighten only.
- Place the M6 x 100 hex head screw and washer into bolt hole #4.
- Follow the sequence below for tightening the fasteners. Tightening of the 2 screws under the rear of the supercharger manifold (1 & 2 in the diagram) is somewhat difficult and will require some patience in getting these tight. Tighten these 2 screws completely before proceeding with the rest of the manifold screws.

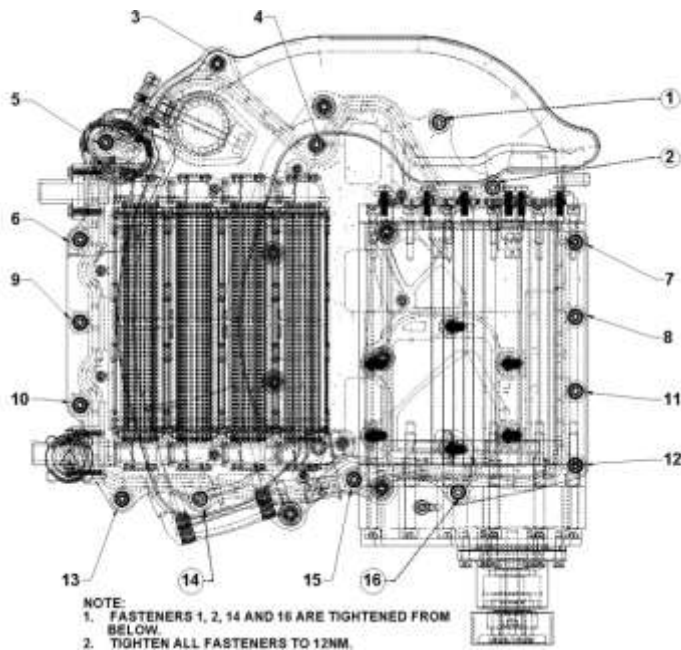

- Make sure all screws have been tightened screws to 12Nm.
- Install #6 cylinder coil, and tighten fastener to 8Nm.
- Connect and lock the coil electrical connector.

21. Install the idler pulley bracket

- Loosely attach the idler bracket to the supercharger drive extension using the strap and two M6 x 12mm screws.



- Attach the bracket to the block with two M6 x 20mm hex screws.
- Attach the rear post of the idler bracket to the cylinder block with the M6 x 12mm screw and washer
- Tighten all fasteners to 12Nm.
- Attach the idler pulleys to the bracket with two M8 x 16mm screws and two 8.5mm x 25mm x 3mm washers, and tighten to 23Nm.

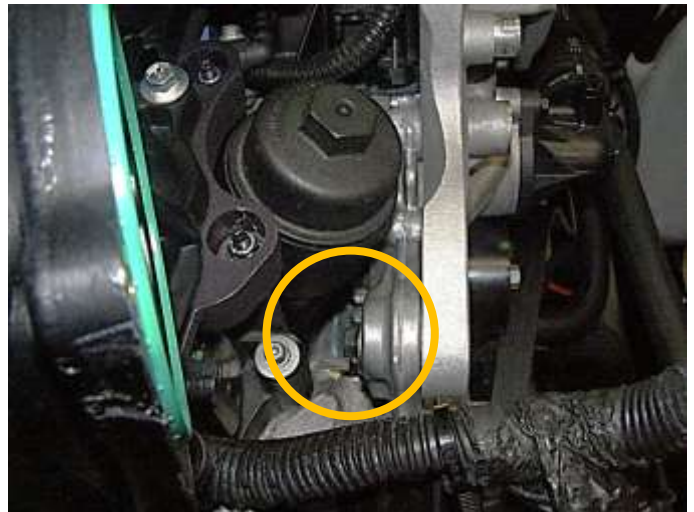

22. Install the drive belt

- Install the new drive belt and re-attach the alternator and bracket making sure to feed the drive belt either side of the post on the back of the alternator mount bracket. (See image) Note that the image shows the bracket separated from the alternator, to provide a clearer picture for the belt routing. It is not necessary to separate the alternator and bracket assembly.
- Tighten the 2 top screws to 54Nm, Tighten the bottom 4 screws to 30Nm.
- Attach the positive battery cable to the alternator and tighten to 13Nm. Re fit the insulating cover over the connection
- Attach the alternator connector
- Install the drive belt over the remaining pulleys. It will be necessary to relieve the tension on the belt tensioner, using a ½” breaker bar.

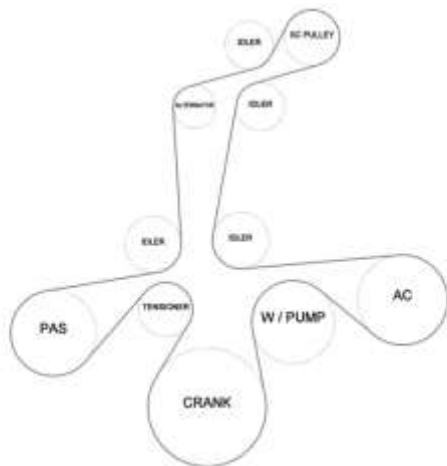

23. Install the throttle body

- Prior to installing the throttle body remove the o-ring seal from the OEM manifold and fit it to the throttle body seal groove of the supercharger manifold.
- Attach the throttle body to the manifold with the four M6 x 40mm SHCS and washers supplied.
- Connect the throttle body extension loom to the throttle body and secure in place with the OEM harness clip and a cable tie supplied.
- Connect the throttle body loom extension to the OEM throttle body connector.
- Trim cable tie.



24. Install the MAP sensor

- Prior to installing the MAP sensor, lubricate the o-ring with rubber grease or white petroleum jelly attach the MAP sensor to the manifold and secure in place with the self-tapping screw supplied and tighten to 6Nm.
- Attach the MAP sensor adaptor to the MAP sensor.



25. Attach engine breather hose

- Connect the engine breather hose to the manifold.



26. Attach intercooler hoses

- Attach the intercooler hoses to the manifold and secure in place with the 26mm spring band clamps supplied.



27. Install the purge solenoid hose

- Attach the EVAP purge solenoid hose to the supercharger manifold.
- Connect other end of hose to the purge solenoid.



28. Install the air box

- Install the air box and attach the engine breather hose



29. Install the clean air duct

- Attach the hose clamps to the clean air duct.
- Connect the intake air temp sensor (IAT) connector.
- Attach the duct to the air box and throttle body, and tighten the hose clamps.



30. Attach vacuum hose

- Attach the OEM brake vacuum hose to the supercharger manifold.



31. Secure hoses

- Make sure all hose are secured with cable ties supplied.



32. Connect battery

- Connect battery terminals and tighten to 7 Nm.
- Note: Always connect the positive battery terminal before connecting the negative terminal to reduce the danger of short circuit through the wrench.



33. Fill intercooler system and vehicle cooling system.

- Remove the intercooler fill cap and fill the system with approximately 1.9 litres of ethylene glycol based automotive engine coolant. Ensure all air is expelled from the system. Air in the intercooler system can reduce engine performance and cause pinging or detonation.
- Make sure that the drain tap is closed and refill the radiator with the coolant previously drained or replace with fresh manufacturer's recommended engine coolant via the coolant reservoir / over flow tank



34. Attach the radiator grille

- Attach the radiator grille by reversing the steps shown in procedure step 3.

35. Re-install the bumper and splash guard

- Attach the Bumper and splash shield by reversing the steps shown in procedure step 2.

36. Load the ECM re-flash

- Read the instructions included with the Diablo SP1000 flash tuner. Intune DCX instructions apply.
- Follow the instructions included with the Diablo SP1000 flash tuner.

PENTASTAR 3.6L V6 JEEP JK SUPERCHARGER SYSTEM

SECTION 3

PRE TEST DRIVE INSPECTION

37. Pre start inspection

- Ensure coolant is at correct level.
- Ensure engine oil is at correct level.
- Ensure vehicle has fresh 95 RON (91 Octane USA) premium unleaded fuel or higher.
- Ensure the belt is correctly installed on each pulley and aligned.
- Ensure the air filter is clean.
- Check & replace spark plugs if necessary. Set gap to factory specification.

SAFETY WARNING: Ensure adequate steps are taken to prevent injury, spillage or fire should any of the required installation steps not have been carried out to specification.

38. Engine warm up

- Start engine and allow it to run until engine reaches normal operating temperature.
- Check for coolant leaks.
- Check the intercooler filler cap coolant level with the engine running and top up the system if required.
- Check engine coolant level and top up if required.

39. Check and adjust supercharger pulley alignment.

- Due to manufacturing tolerances of the original parts, it may be necessary to adjust the alignment the supercharger pulley to meet the other pulleys in the system, either remove or add shims supplied to align the belt. If required, add another shim into the pulley to bring the pulley forward to align the belt as necessary. If the 1mm shim is removed from the pulley to achieve correct belt alignment, the use the shim removed as a washer underneath the pulley bolts when attaching the pulley.
- Remove the 4, M6 x 20mm SHCS.
- Relieve the belt tension and remove the belt from the pulley and remove the pulley from the drive extension.
- Place the shim into the pulley and re-attach the pulley and belt.
- Tighten the screws to 12Nm.



40. Road test

- Road test vehicle.
- Recheck all joints and connections for leaks and rectify as necessary.
- Check intercooler system coolant level and top up as necessary.
- Check engine coolant level and top up as necessary.

PENTASTAR 3.6L V6 JEEP JK SUPERCHARGER SYSTEM

SECTION 4

MAINTENANCE INSTRUCTIONS

41. Supercharger belt replacement

- It is recommended that the supercharger drive belt be checked at every regular service and be replaced at 50,000 km (30,000 miles) or 2 years, whichever occurs first.

42. Supercharger gear case oil change interval

- Drain and replace the supercharger oil every 50,000 km or 30,000 miles, use Redline 75W90 NS gear oil or equivalent.
- It is critical not to overfill the supercharger gear case as damage will occur.
- Fill with exactly 60 millilitres or 2.03 US fluid ounces.
- Make sure vehicle is parked on level ground before checking oil level, check the oil level in the supercharger assembly, using the dipstick provided, Tighten the dipstick fully before checking the oil level.

43. Supercharger gear case oil change procedure

- Make sure the vehicle is parked on level ground before checking the oil level. Allow sufficient time for the oil level to settle after the engine has been run.
- Remove the dipstick from the gear case.
- Using a syringe and a 190mm long piece of tube draw out as much oil as possible from the gear case.
- Fill the gearbox with Redline 75W90 NS gear oil or equivalent.
- Check oil level with the dipstick provided in the supercharger.
- Refit the dipstick and tighten to 10Nm.



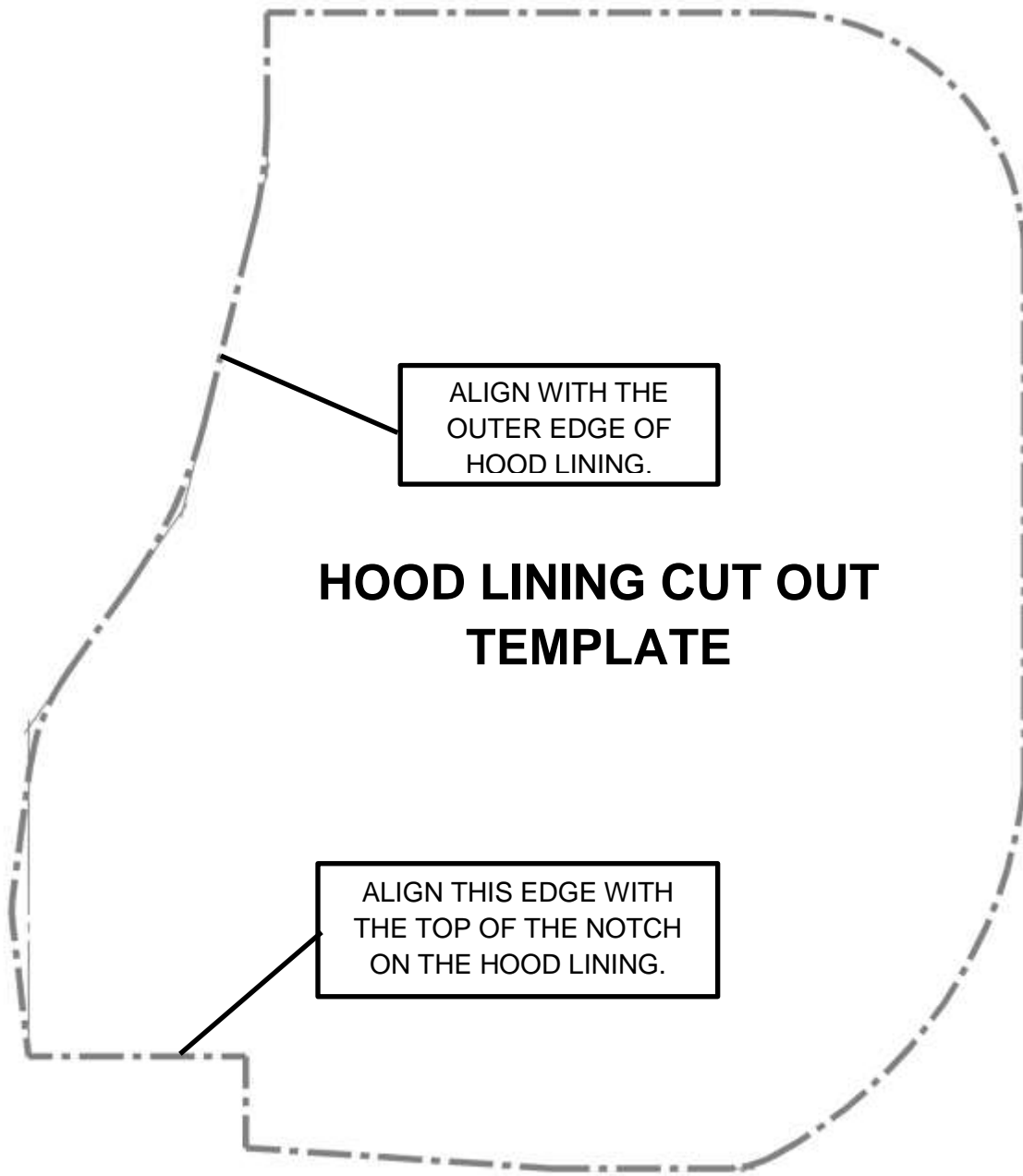

ALIGN WITH THE
OUTER EDGE OF
HOOD LINING.

HOOD LINING CUT OUT TEMPLATE

ALIGN THIS EDGE WITH
THE TOP OF THE NOTCH
ON THE HOOD LINING.