

INSTRUCTION DATA

PRODUCT: LED180

VER: 1.1

DATE: JUNE 2014

LIGHTFORCE™

PERFORMANCE LIGHTING

LIGHTFORCE LED180

KIT CONTENTS:

- 1 x LED 180 light
- 1 x Clear filter (fitted to light)
- 1 x Mounting bracket
- 3 x M10 x 35mm stainless steel bolts
- 2 x M10 small stainless steel washers
- 1 x M10 large stainless steel washers
- 1 x 2 pin Deutsch waterproof connector
- 1 x User instructions

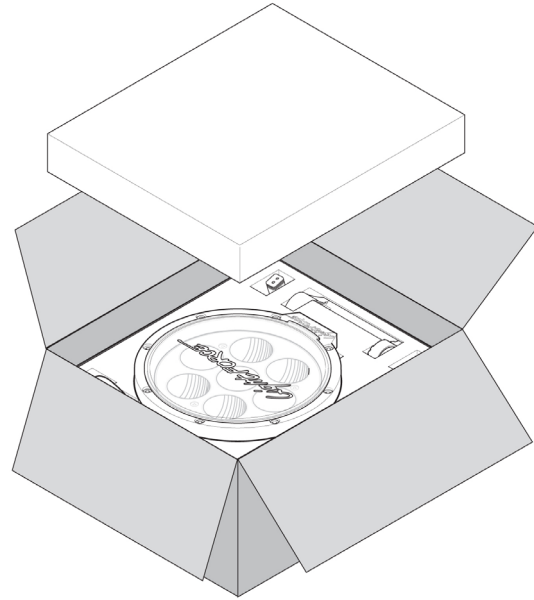

INSTALLATION GUIDE:

TOOLS REQUIRED:

- 17mm socket on ratchet
- Torque wrench

GENERAL CARE AND SAFETY TIPS:

To wash your lights, use plenty of warm soapy water and a soft cloth only (this prevents the surface from marking). If cleaning the INSIDE face of your filter, use copious amounts of water and a soft cloth.

CAUTION:

Never use any solvent based cleaners or industrial detergents when cleaning your lights.

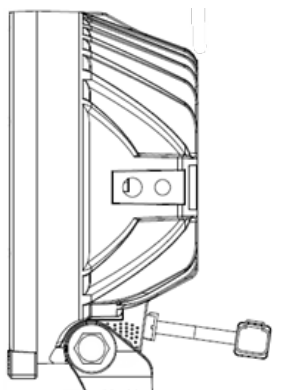

Image 1

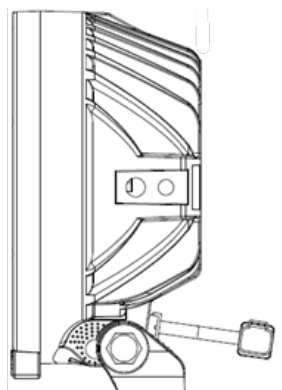

Image 2

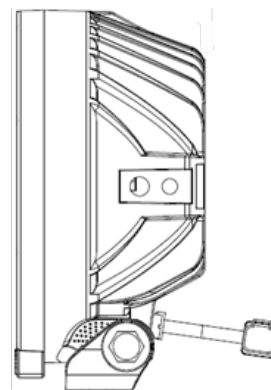

Image 3

MOUNTING:

LED 180 can be mounted in three different positions (two cross-bolt holes and a reversible mount; see picture)

Before fitting the mount, insert the mounting bolt then select the most suitable position for your application.



The optimum mounting position for best center of gravity is image 1 with the mount in the forward position.

Turn the light upside down to insert the M10 nuts in the forward or aft position as shown.

IMPORTANT NOTE:

Before fitting the stainless steel hardware apply a small amount of anti-seize to the threads of all bolts.

Then slide the mount on aligning the holes of the mount to the holes on the body of the light that have the M10 nuts fitted.

Using the supplied M10 x 35mm stainless steel bolts and small washers insert them through the mount into the body of the light to engage the bolts.

MOUNTING CONTINUED:

- Fit light into position using the large stainless steel washer provided then affix the M10 nut to the bolt until firm.
- Align the light and then tighten all bolts as per recommended torque specifications (see specifications section).

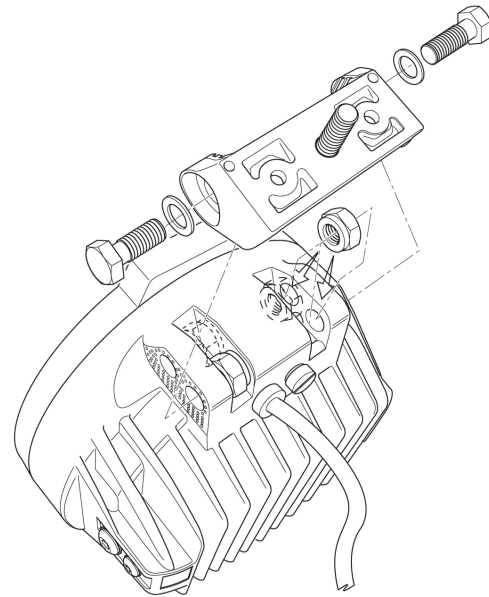

NOTE:

Mounting points vary in design and load capacity, ensure the light is within manufactures recommended weight specifications.

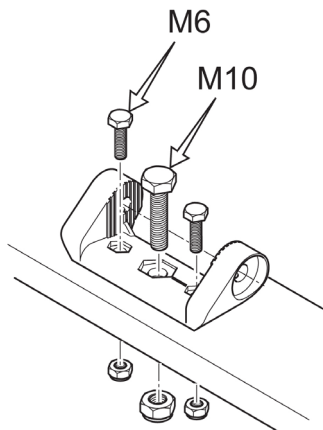

NOTE:

M6 Mounting bolts - If extra mounting security is required or you have a problem with your light rotating, there are two M6 mounting holes either side of the main M10 mounting bolt. These will accommodate any M6 bolt with an 11mm head size.

ELECTRICAL CONNECTIONS:

The LED 180 is fitted with a waterproof electrical connector, included is the matching connector fitted to a short length of cable for connection with an existing wiring harness. This harness needs to be fitted directly to your driving light loom.

- Red cable to positive supply
- Black cable to negative supply

Note if you are using a non Lightforce harness the 2 pin connector on your existing harness may need to be changed

CAUTION:

Improper installation of the connector will affect the reliability and operation of your lights.

Do not remove waterproof connector from the driving light cable; this will lead to water ingress and void warranty.

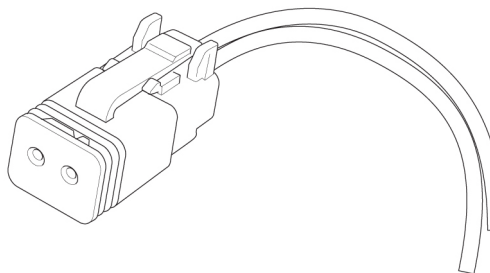

The LED 180 has additional mounting points on each side and top of the housing. The side mounting points have a captive M6 and M8 nut with the top mounting point. A M5 x 0.8 thread 10mm in depth this point is suitable for attaching a stay bar for increased stability.

REMOVING AND REFITTING THE FILTER:

Filter Removal

- Insert coin at bottom of light between filter tab and bezel
- Twist coin and using the tab pull filter away from bezel

Refitting

- Insert the filter at the top position
- Push filter onto bezel using filter tab at bottom until side clips are engaged
- Ensure filter is correctly aligned within bezel

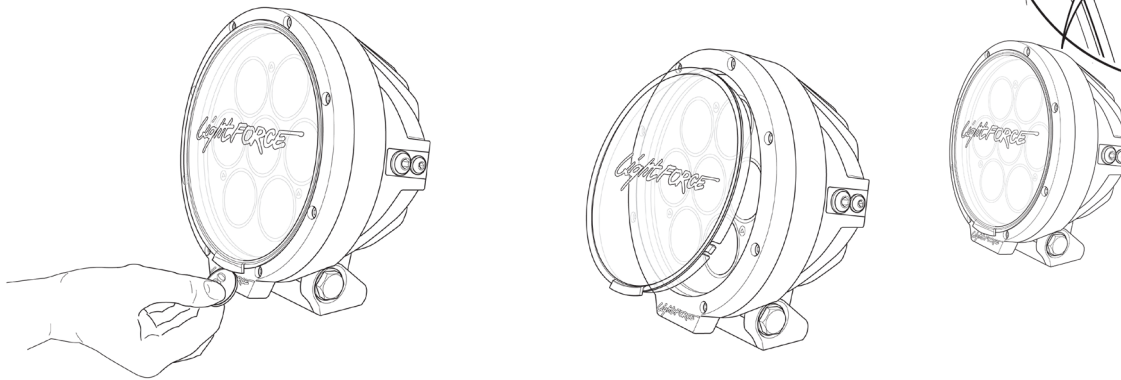
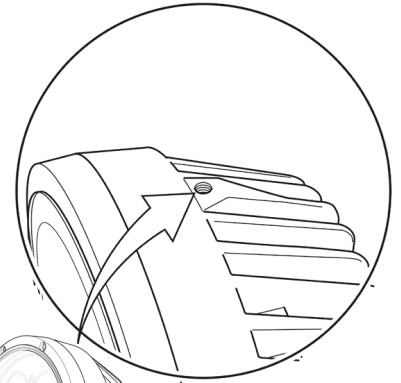

CAUTION

When handling the filter, take care of the surface as this can mark easily (for cleaning see 'General Care and Safety Tips' section).

TECHNICAL SPECIFICATIONS:

- 70W (7 x 10w CREE chipsets)
- Input voltage range: 10-36V DC
- Current draw: 4.8A @ 13.2v
- Colour temperature: 5000K
- 50,000+ Hour LED lifespan
- Input cable 450mm (17.72")
- Operating temperature -40°C to 63°C (-40°F to 145°F)
- Dimensions 181mm (W) x 196mm (H) x 97mm (D) (7.12"(W) x 7.72" (H) x 3.82"(D))
- Weight 2.1kg (4.6lb)
- Top mounting point thread M5 x 0.8 depth 10mm (0.39")

RECOMMENDED WIRE SIZE:

2.0mm² (14AWG) MINIMUM

MOUNTING FASTENER TORQUE SPECIFICATIONS

M10 x 30mm bottom mount bolt - 35Nm (26lb-ft)
M10 x 30mm cross-bolt - 35Nm (26lb-ft)

WARNING:

The bolts that retain the mount to the light cannot exceed 35mm in length otherwise damage to the housing can occur.



Australia

"Lightforce" means Lightforce Australia Pty Ltd ABN 54 069 439 774 Address: 28 Orsmond Street, Hindmarsh, SA, 5007. Telephone: +61 8 8440 0888. Email Address: sales@lightforce.net.au

"Lightforce Affiliates" means Lightforce, Lightforce's related bodies corporate (within the meaning of the Corporations Act 2001), and their respective employees, officers, agents and contractors.

"Warranty Period" means:

(a) For Lightforce products (excluding bulbs and batteries, Custom Built products and mounts and Ace Precision Rifle Systems products) manufactured in Australia and sold either in Australia or overseas, three (3) years from the date of purchase specified on your sales receipt or invoice unless otherwise notified by Lightforce in writing prior to or at the date of purchase;

(b) For

1) Lightforce products and accessories manufactured outside, but imported into, Australia; and

2) Custom Built products and mounts (wherever manufactured);

3) sold in Australia or overseas (but in each case excluding bulbs and batteries, and Ace Precision Rifle Systems products), one (1) year from the date of purchase specified on your sales receipt or invoice unless otherwise notified by Lightforce in writing prior to or at the date of purchase.

What this warranty covers:

Lightforce warrants that it will, at its option, replace or repair each product that you purchase which, during the Warranty Period, has a defect in materials or workmanship under normal use and conditions.

Statutory rights:

Our products come with guarantees that cannot be excluded under the Australian Consumer Law. You are entitled to a replacement or refund for a major failure and compensation for any other reasonably foreseeable loss or damage. You are also entitled to have the products repaired or replaced if the products fail to be of acceptable quality and the failure does not amount to a major failure.

In addition, the benefits given by this warranty are in addition to your rights and remedies under a law in relation to the products.

Replacement of a product or parts:

When warranty service involves the replacement of a product or a part, the replaced product or part becomes Lightforce's property. Only unaltered Lightforce products and parts are eligible for replacement. The replacement product or part is warranted for the balance of the period remaining on the original product. Products and parts presented for repair may be replaced by refurbished product or parts of the same type rather than being repaired or replaced with new parts.

Procedure for claiming:

Australia: Make contact with the Lightforce sales office at the above address. We will attempt to resolve the issue over the phone, or we may issue a warranty case notice to arrange return of the product for assessment. Lightforce will not be able to perform our service under this warranty if you refuse to return the product to us for inspection.

Claims in respect of defects covered by this warranty must be made as soon as possible after such defect becomes apparent and, in any event, not later than thirty (30) days after the end of the Warranty Period.

International: Contact the point of purchase for warranty service

Cost of claiming:

Under this warranty and, unless Lightforce otherwise agrees in writing, you bear the cost of claiming under this warranty including the cost of returning the product to Lightforce.

Under this warranty, Lightforce is responsible for loss or damage to your product only while it is in the possession of Lightforce Affiliates.

Use of personal information:

This warranty will not apply if you do not supply to us or to our Lightforce Affiliates information that we reasonably request to enable us to perform our obligations under this warranty. You have the right to access your personal contact information and request correction of any errors in it pursuant to the Privacy Act 1988 by contacting Lightforce.

Limitation of liability:

Where permitted, or not prohibited, under any law, including under the Australian Consumer Law, Lightforce's and Lightforce Affiliates' liability in respect of any defect in materials or workmanship or in respect of a product which is not otherwise of acceptable quality (within the meaning of the Australian Consumer Law), is limited at the option of Lightforce, to:

(a) The replacement or repair of the product,

(b) The payment of the cost of replacing or repairing the product; or



(c) The payment of the cost of acquiring an equivalent product

Accordingly, to the extent permitted or not prohibited under any law (including the Australian Consumer Law):

(a) neither Lightforce nor any Lightforce Affiliates are liable under any circumstances (including in contract, negligence or other tort, or under any other legal doctrine) for:

1) third party claims against you for damages;

2) special, incidental, punitive, indirect or consequential damages, including but not limited to lost profits, business revenue, goodwill or anticipated savings; and

(b) in no case does the total liability of Lightforce, Lightforce Affiliates, or their respective suppliers, resellers or service providers to any person for damages from any cause (including in contract, negligence or other tort, or under any other legal doctrine), in connection with the supply of a product exceed the lesser of the actual direct damages of that person and the amount paid for the product by that person.

The foregoing limitations do not apply to damages for bodily injury (including death), damage to real property or damage to tangible personal property for which Lightforce is liable under any non - excludable law.