

Jeep Wrangler

X009-WRA 9"

Installation Manual

- Model: Wrangler
- Model Year: 2011-UP

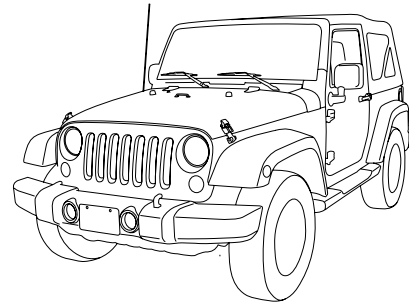

Jeep	Model	Year
	Wrangler	2011 - UP

* The specified vehicles have been tested and have met compatibility specs at the time of testing. Compatibility is not guaranteed if the manufacturer has made production changes to the listed vehicles above.



Introduction

- Design and specifications are subject to change without notice for improvement.





To Ensure Safe Use, Always Follow These Precautions

- The installation of this product requires specialized skills and experience. We recommend that you have the product installed by the store that you purchased it from.
- Before you use this product, be sure to carefully read this installation manual and the separate user's manual so that you can use the product correctly. Alpine Electronics bears no responsibility for problems that arise as a result of failure to follow the instructions in the manuals.
- This manual includes a number of symbols that are intended to help you use the product safely, to prevent harm to you and others, and to protect against damage to property. These symbols and their meanings are listed below. Make sure you fully understand these symbols before you begin reading the main text.

Explanations of Injury and Damage That May Result from Incorrect Use

 Warning	Ignoring the content marked by this indication and using the product incorrectly is expected to lead to death or serious injury.
 Caution	Ignoring the content marked by this indication and using the product incorrectly is only expected to lead to injury or property damage.

Types of Precautions

 Forbidden	Indicates actions that are forbidden (must not be performed)	 Mandatory	Indicates actions that are mandatory (must be performed)
 Forbidden	Indicates that disassembly is forbidden.		Marks content that should receive your full attention.

 **Warning**

Do not disassemble or modify the product. Doing so could lead to an accident, fire, or electric shock.



Forbidden

Store screws and other small objects where small children cannot reach them. If one of these small objects is swallowed, consult with a doctor immediately.



When replacing fuses, be sure to use fuses with the specified current rating. Failing to do so could lead to an accident or fire.



Forbidden



Mandatory

Only connect the product to a 12 VDC negative ground car. Failing to do so could lead to an accident or fire.



Mandatory

Before you begin wiring, remove the ground wire from the negative terminal of the battery. Failing to do so could lead to electric shock or injury.



Do not cut the insulation on a cord and take power from another device. Doing so could lead to fire or electric shock.



Forbidden

Do not install the product in a location where it will obstruct the driver's forward view; interfere with the operation of the steering wheel, gearshift, or the like; or pose a threat to passengers. Doing so could lead to an accident or injury.



Forbidden

When making a hole in the vehicle body, be careful to avoid damaging pipes, the fuel tank, electrical wiring, and the like. This kind of damage could lead to an accident or fire.



When installing and grounding the product, do not use any of the bolts or nuts of the steering wheel, brakes, fuel tank, or the like. Doing so could make the brakes stop working or lead to fire.



Forbidden

Do not install the product near the passenger-side airbag. Doing so could interfere with the operation of the airbag and lead to an accident or injury.



Forbidden

Bundle cords so that they don't interfere with driving. Wrapping cords around the steering wheel, gearshift, brake pedal, or the like, could lead to an accident or damage equipment.



 **Caution**

Connect the product properly according to the instructions. Failing to do so could lead to fire or an accident.



Forbidden

Do not sandwich cords between the seat railing or allow them to touch protrusions. Resulting breaks or shorts could lead to electric shock or fire.



Do not block vents or heat sinks. Doing so could lead to fire or damage equipment.



Use the accessories according to the instructions, and attach them securely. Failing to do so could lead to an accident or damage equipment.



Forbidden

Do not install the product where it may be exposed to water or in a place with high levels of humidity or dust. Doing so could lead to fire or damage equipment.







Forbidden

The installation and wiring of this product requires specialized skills and experience. Have the product installed and wired by the store that you purchased it from.



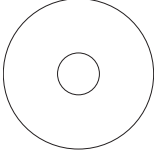
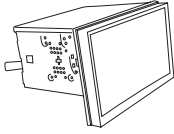
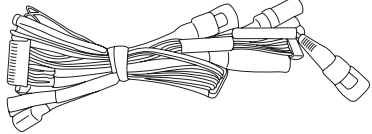
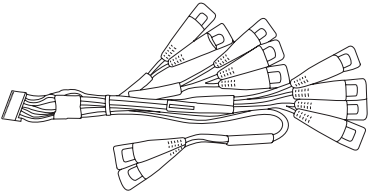
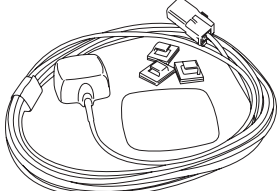
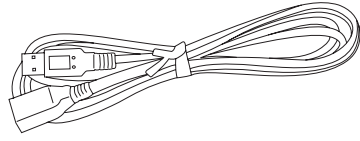
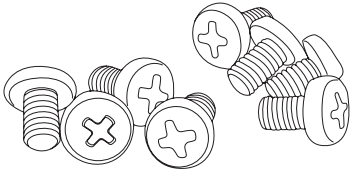

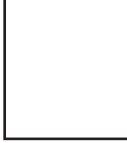

Accessory List

Head Unit Box Parts (X009)

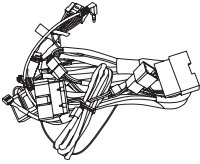
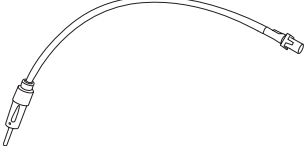
<p>Owner's Manual Disc</p>	<p>X009 Head Unit</p>	<p>X009 Camera Harness</p>
		
<p>AUX/Pre Out Harness</p>	<p>GPS Antenna</p>	<p>USB Extension Cable</p>
		
<p>8mm x 8 Screws</p>	<p>Quick Reference Guides</p>	<p>Registration Cards</p>
	<div style="display: flex; justify-content: space-around;"> <div data-bbox="639 932 764 1073">  <p>QRG Audio</p> </div> <div data-bbox="854 932 979 1073">  <p>QRG Navigation</p> </div> </div>	<div style="display: flex; justify-content: space-around;"> <div data-bbox="1101 932 1226 1073">  <p>Alpine Registration Card</p> </div> <div data-bbox="1320 932 1445 1073">  <p>NAVTEQ Registration Card</p> </div> </div>

iDatalink Maestro Box Parts (ALP-MRR V2.0/ALP-HRN-WRA V2.0)

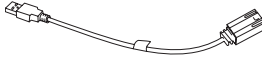
<p>Main Harness</p>	<p>Antenna Adapter</p>	<p>iDatalink Maestro Module</p>
		
<p>SAT Radio Antenna Adapter</p>	<p>Maestro Module USB Flashing Cable</p>	<p>OEM USB Adapter</p>
		

Installation Kit Parts (G-KTX-009-WRA)

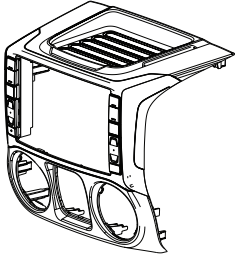
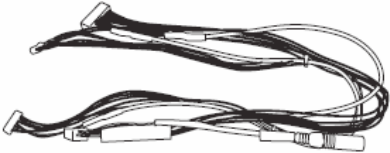
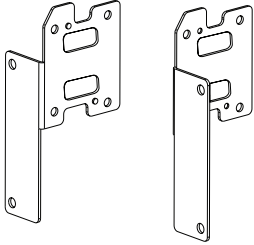
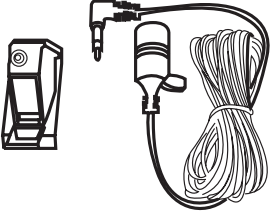
X009-WRA Radio Dash Bezel	Key Harness	Side Mounting Brackets
		
<p>Microphone</p>		
		

Component Locations

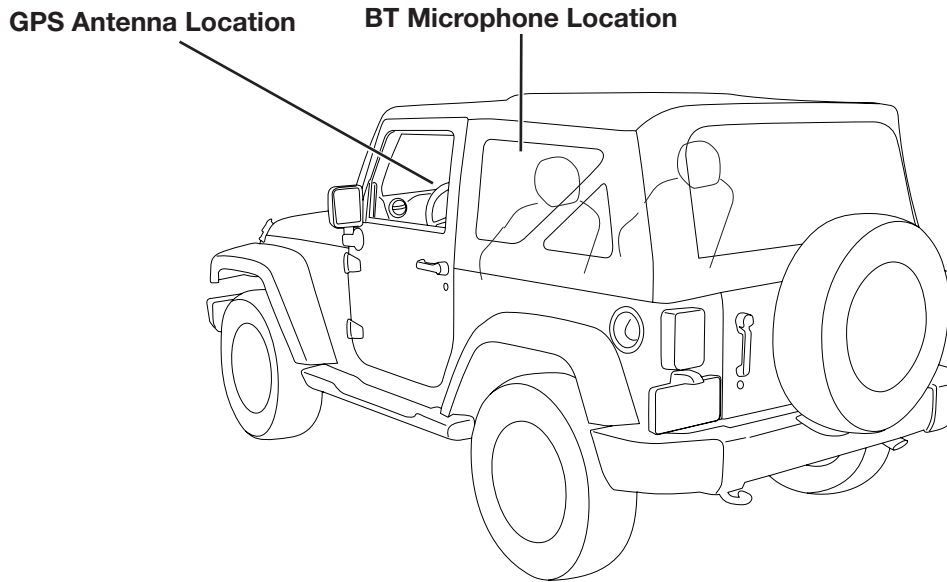
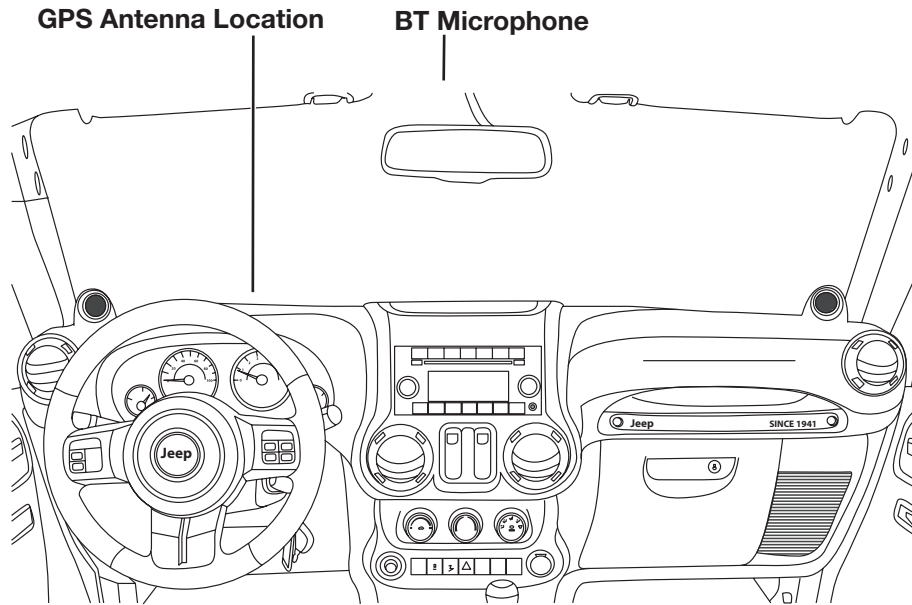

Factory Unit Disassembly Process

- 1** Remove the rubber cover from the top center storage area and extract 1 x 7mm screw.

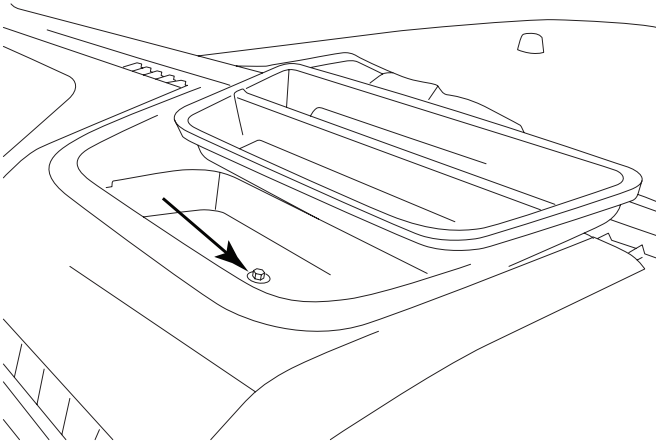

- 2** Remove the knee cover panel and extract 2 x 7mm screws located to the right and left sides of the steering wheel column.



- 3** Remove the window switch pod using a panel removing tool and extract 1 x 7mm screw.

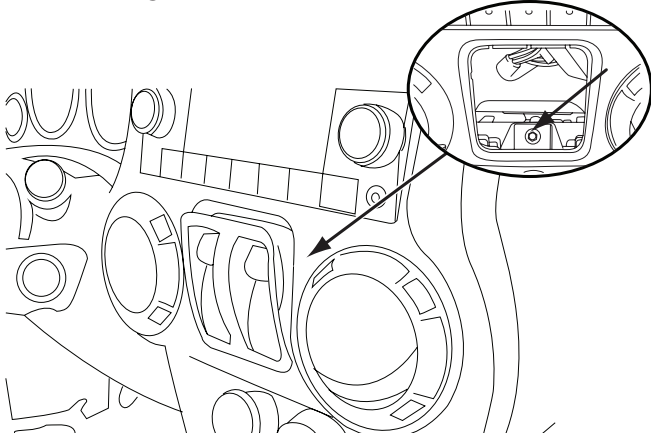

- 4** Remove the dash panel.

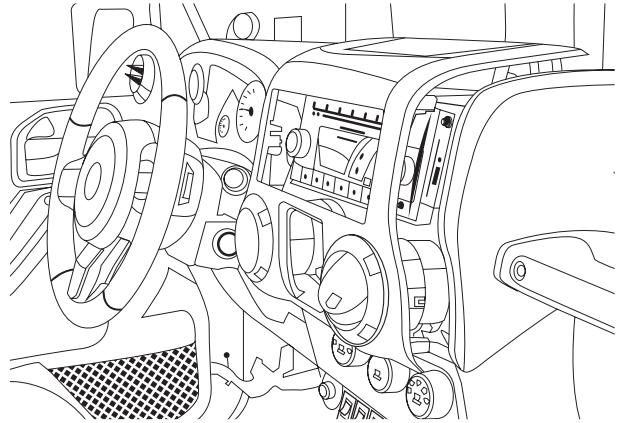

Programming the iDataLink Maestro Module

1 INSTALL THE WEBLINK PLUG-IN

Go to:
idatalinkmaestro.com/plugin and follow the installation steps.

Review the System Requirements before installing.



If the plugin is already installed, the caution, “The plugin is already installed” appears. Please skip to step 2.

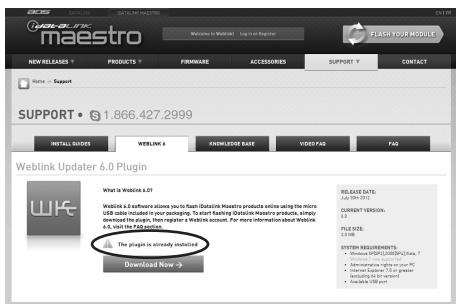

2 REGISTER A WEBLINK ACCOUNT

Go to:
idatalinkmaestro.com/register and complete the registration process.

A confirmation email will be sent to you requiring validation.

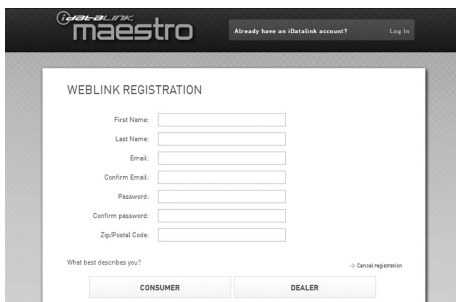

For existing customers, click log in.



3 CONNECT YOUR MAESTRO MODULE

Use the included USB cable to connect your Maestro module to your PC.

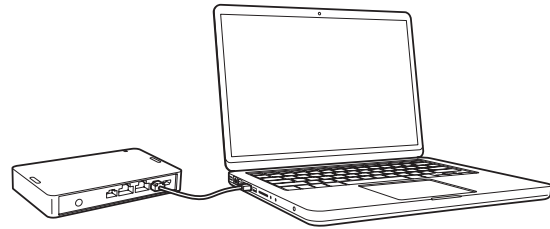

4 LOG INTO WEBLINK

Go to:
idatalinkmaestro.com/login.
Enter your username and password, then click OK.



5 PROGRAM YOUR MODULE

Follow the programming steps for your vehicle.



6 Once Programming is complete “FLASHING COMPLETED!” will be displayed.

Proceed to the next page to complete installation.



Installation Instructions

- 1 Attach the Maestro to the main harness.

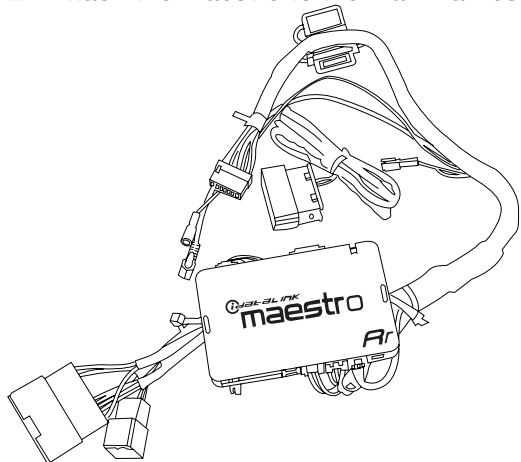

- 2 Mount the microphone as illustrated and run the cable to the radio cavity.

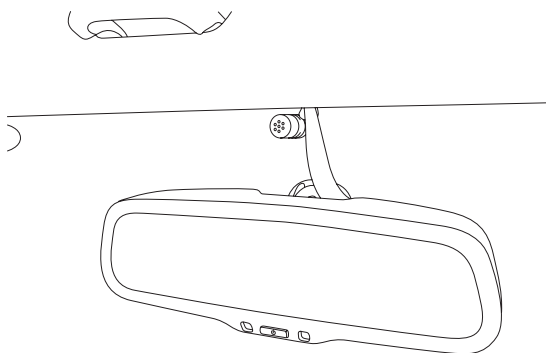

- 3 Connect the main harness, antenna, and other adapters to the factory harness and secure it.

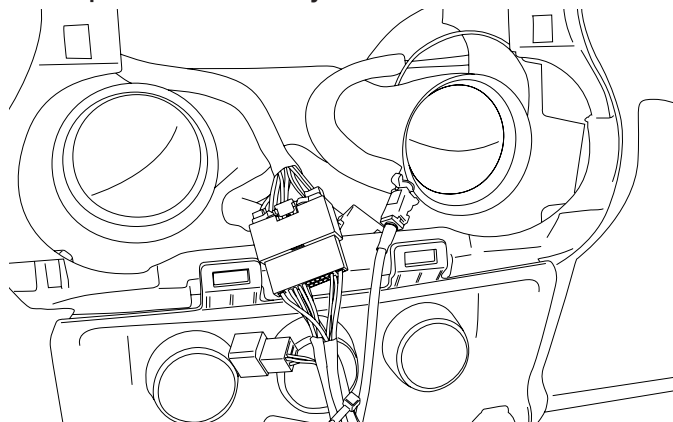

- 4 Place GPS antenna next to the instrument panel as illustrated and run the cable to the radio cavity.

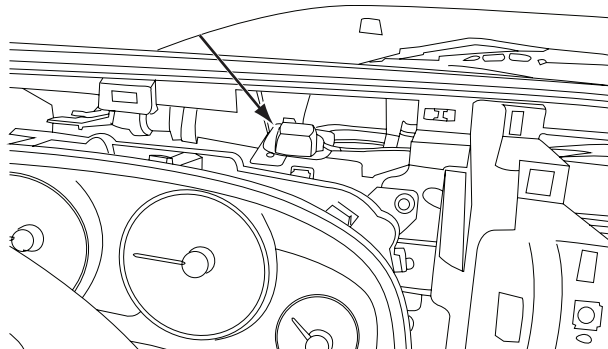

- 5 Plug the OBDII connector on to the OBDII port below the driver side dash and run the extension to the radio cavity.

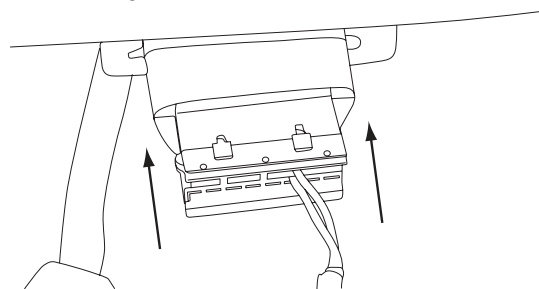

Trimming procedure for dash panel

The factory dash panel needs to be trimmed to allow the new X009-WRA bezel to fit into place. Remove the highlighted area by cutting along the dashed line.

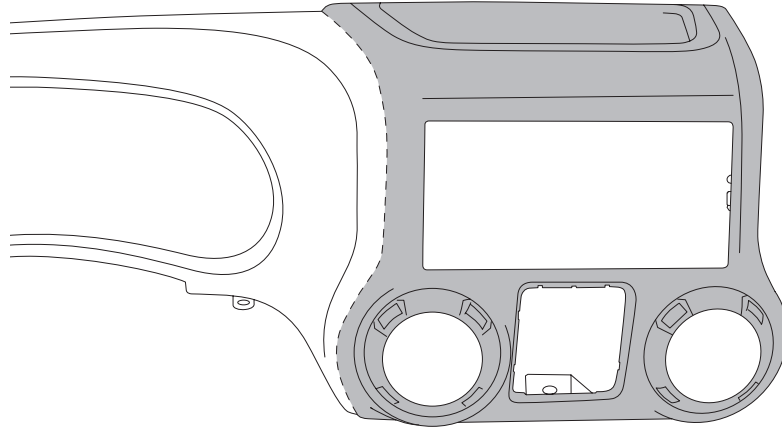

Mount the modified panel back on the vehicle.

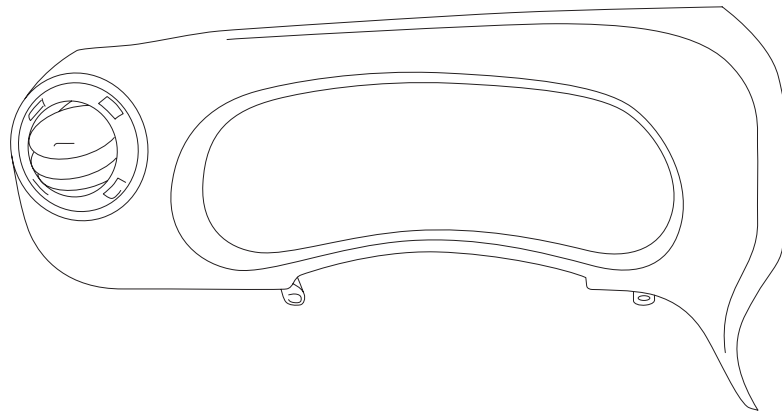

Installation Instructions

- 1 Remove the vents from the radio section on the OEM dash panel by pressing down on the lock tab and turning right. Mount vents on to the X009-WRA bezel.

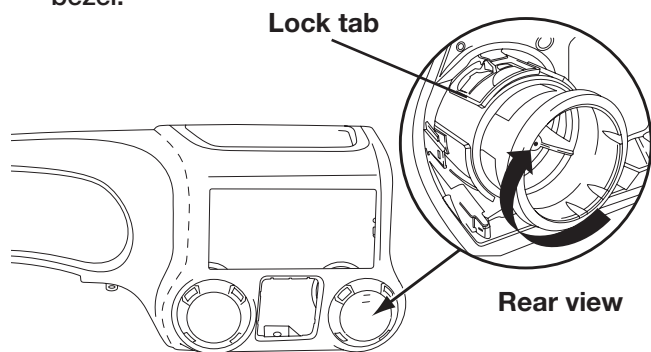

- 2 Extract 2 x 7mm screws from the OEM radio bracket and remove it.

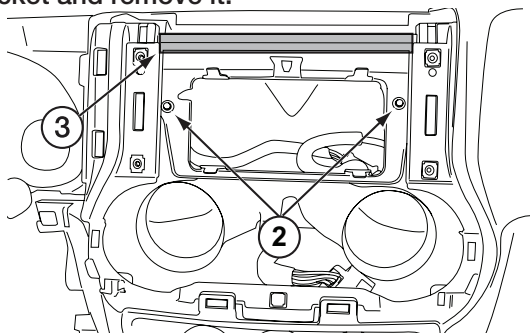

- 3 Use a cutting tool to trim the highlighted area shown above.
- 4 Attach the brackets using the provided screws.

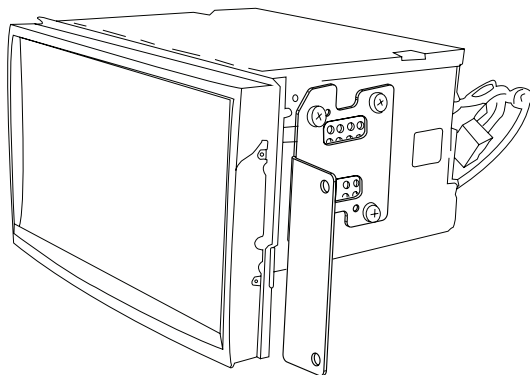

- 5 Run the key harness through the top-left side of X009 headunit. Mount the X009 headunit using 4 x 7mm factory screws.

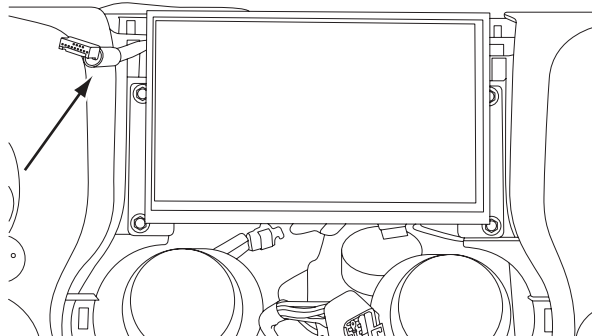

- 6 Connect the radio bezel and snap it into place.

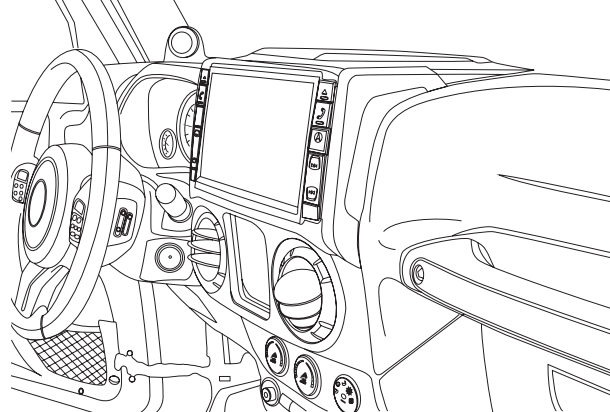

Exploded-View Diagram

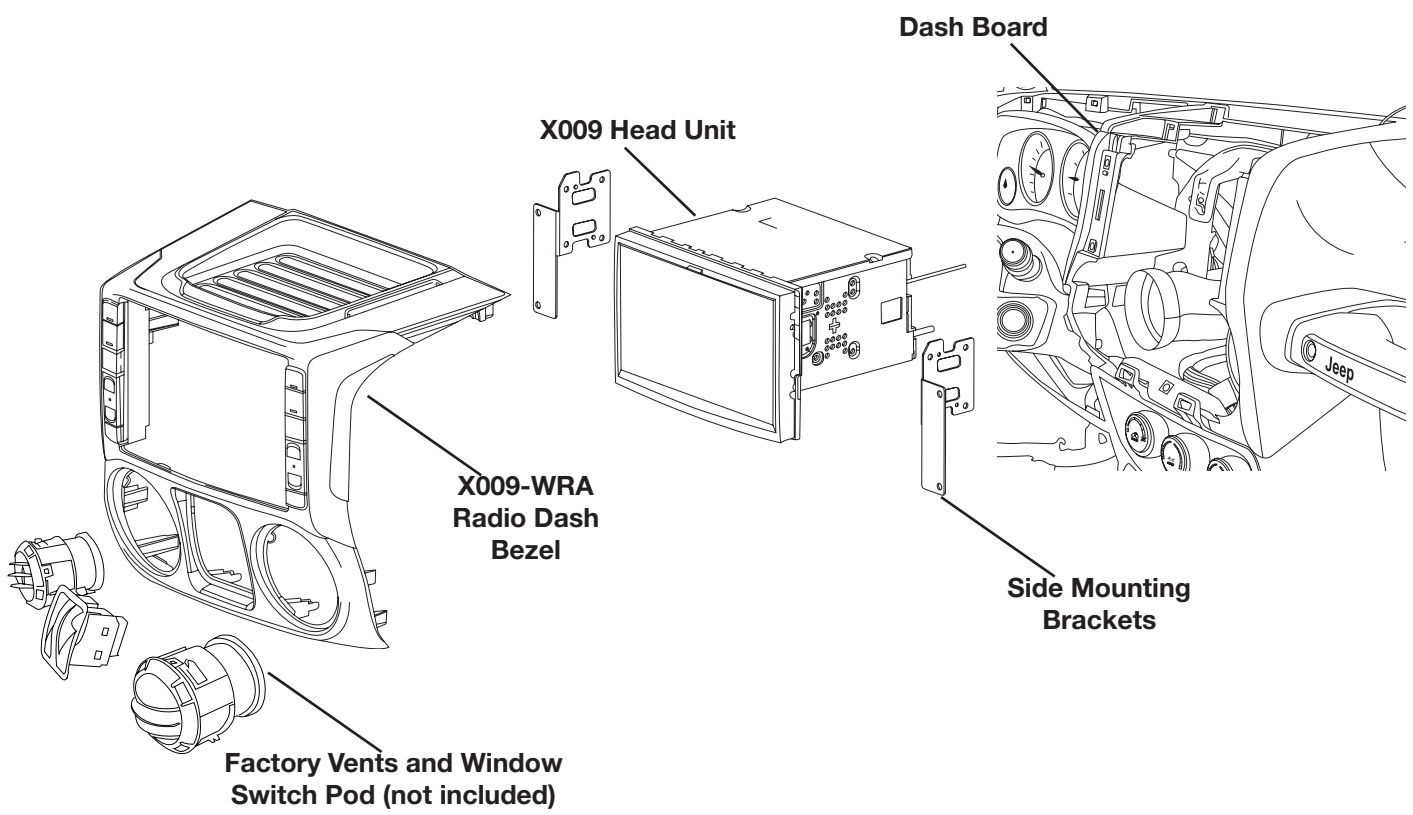

Bezel Wiring Diagram

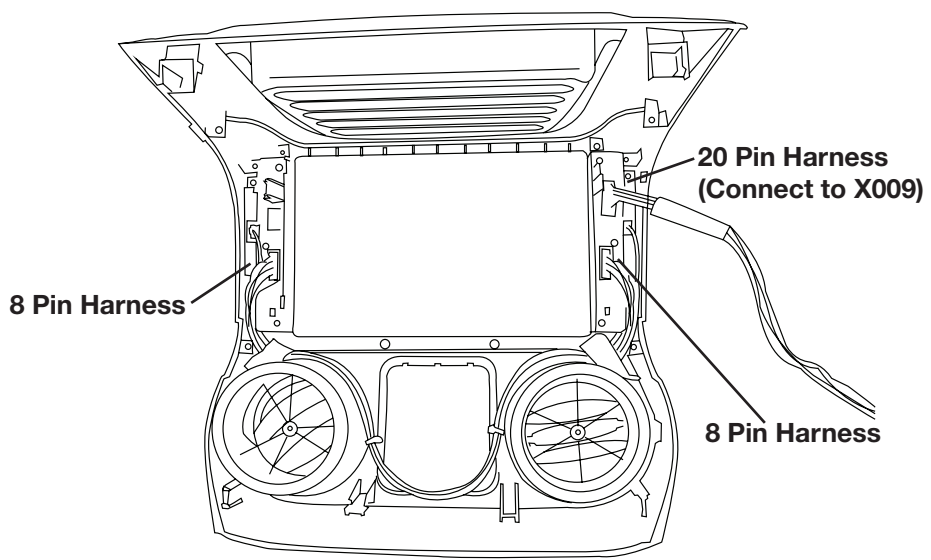

X009-WRA System Wiring

