

INSTALLATION INSTRUCTIONS

PART NUMBER 30477 & 50477

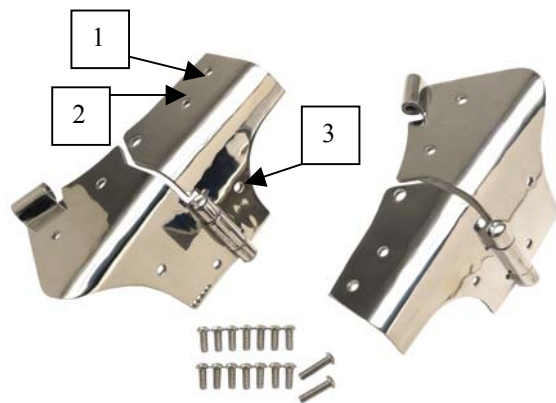

Note: The factory bolts have been installed using a thread locking cement, and sometimes are difficult to remove unless heat is applied to the head of the bolts. The factory has also put a threaded back-up steel plate inside the windshield to accept the bolts, this plate could fall inside the windshield. Loosen all the upper bolts one at a time then remove the bolts following the instructions below.

Remove the bolts in the upper portion of the hinge one at a time. With one 1 bolt removed, insert the 5/16" stud provided to hold the back-up plate in position. Remove the second bolt 2, then remove the third bolt, 3. Remove the last bolt in the upper portion and insert a stud to hold this back-up plate in position.

Remove all the lower bolts.

Place the stainless steel hinge in place and start all bolts except where the studs are. Remove the studs one at a time and insert a stainless bolt in its place. Tighten all bolts at this time.

Repeat this process for the other side.

We recommend that you use anti-sieze on all threads of the stainless bolts provided with your parts.

INSTALLATION INSTRUCTIONS

PART NUMBER 30477 & 50477

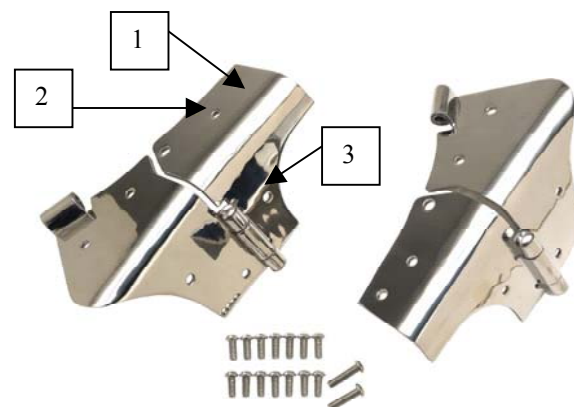

Note: The factory bolts have been installed using a thread locking cement, and sometimes are difficult to remove unless heat is applied to the head of the bolts. The factory has also put a threaded back-up steel plate inside the windshield to accept the bolts, this plate could fall inside the windshield. Loosen all the upper bolts one at a time then remove the bolts following the instructions below.

Remove the bolts in the upper portion of the hinge one at a time. With one 1 bolt removed, insert the 5/16" stud provided to hold the back-up plate in position. Remove the second bolt 2, then remove the third bolt, 3. Remove the last bolt in the upper portion and insert a stud to hold this back-up plate in position.

Remove all the lower bolts.

Place the stainless steel hinge in place and start all bolts except where the studs are. Remove the studs one at a time and insert a stainless bolt in its place. Tighten all bolts at this time.

Repeat this process for the other side.

We recommend that you use anti-sieze on all threads of the stainless bolts provided with your parts.