



INSTALLATION INSTRUCTIONS

JK 2011+ DECK ENCLOSURE #326 (2 & 4 Door)

Please read and fill out the enclosed warranty registration card to activate your warranty.

SHIPMENT CONTENTS



#3 Lid

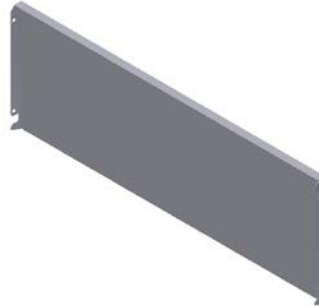

#7 Front Panel



#4 Left Panel



#5 Right Panel



#9 Left Mounting Bracket



#7 Right Mounting Bracket

HARDWARE PACKAGE

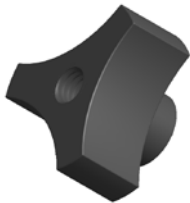

#8.10 (6) 5/16 Wing Knob Nuts



#8.15 (6) 5/16 x 3/4" Carriage Bolt



#8.9 (6) 3/8 Washer

TOOLS REQUIRED

- T-30 Torx (Ratchet or wrench)
- Flat head screwdriver (Recommended)

ATTENTION:

- **THIS ENCLOSURE WAS DESIGNED FOR A STOCK OEM VEHICLE, ANY MODIFICATIONS MADE MAY AFFECT THE FIT INCLUDING: CARPET REMOVAL/CHANGES, SEATS, ETC.**
- **On Jeep Wrangler JK vehicles with Manual Door Locks only, the rear tailgate lock must be locked manually with key in order for Tuffy enclosure security to function. Vehicles with Power Door Locks by default also feature Remote Keyless Entry and the Vehicle Security Alarm. Arming of the Vehicle Security Alarm (by locking the doors with either the key fob or interior power door lock switch) automatically disables the interior power door lock switches and ensures the tailgate and Tuffy enclosure are secure, even on softtop models or with the top removed. There is a 16-second alarm arming period during which the interior power door lock switches remain active.**
- **For safety do not place any items on top of the enclosure that are not adequately secured to the vehicle to prevent movement in the event of an accident or abrupt speed changes.**

INSTALLATION:

PLEASE READ ALL SAFETY WARNINGS AND INSTRUCTIONS THOROUGHLY BEFORE STARTING INSTALL

1. Remove the (2) forward OEM bolts #11.1 with the tie down strap loops #11.4 from the vehicle plastic molding #11.5 and #11.3. These will be reused. (See Figure 1)
2. Insert the #9 and #10 mounting brackets under the carpet #11.6 and under the OEM plastic molding #11.5 and #11.3 ensuring that the holes on the brackets are lined up with the holes where #11.1 OEM bolts were removed. Use the flathead screwdriver to pry up the plastic molding from underneath the cubby cover so space is created when inserting the brackets. (See Figure 1)
3. Reinstall the OEM bolts #11.1 and tie down strap loops #11.4 in their original location. This secures the mounting brackets #9 and #10 to the vehicle floor. (See Figure 1)

Figure 1

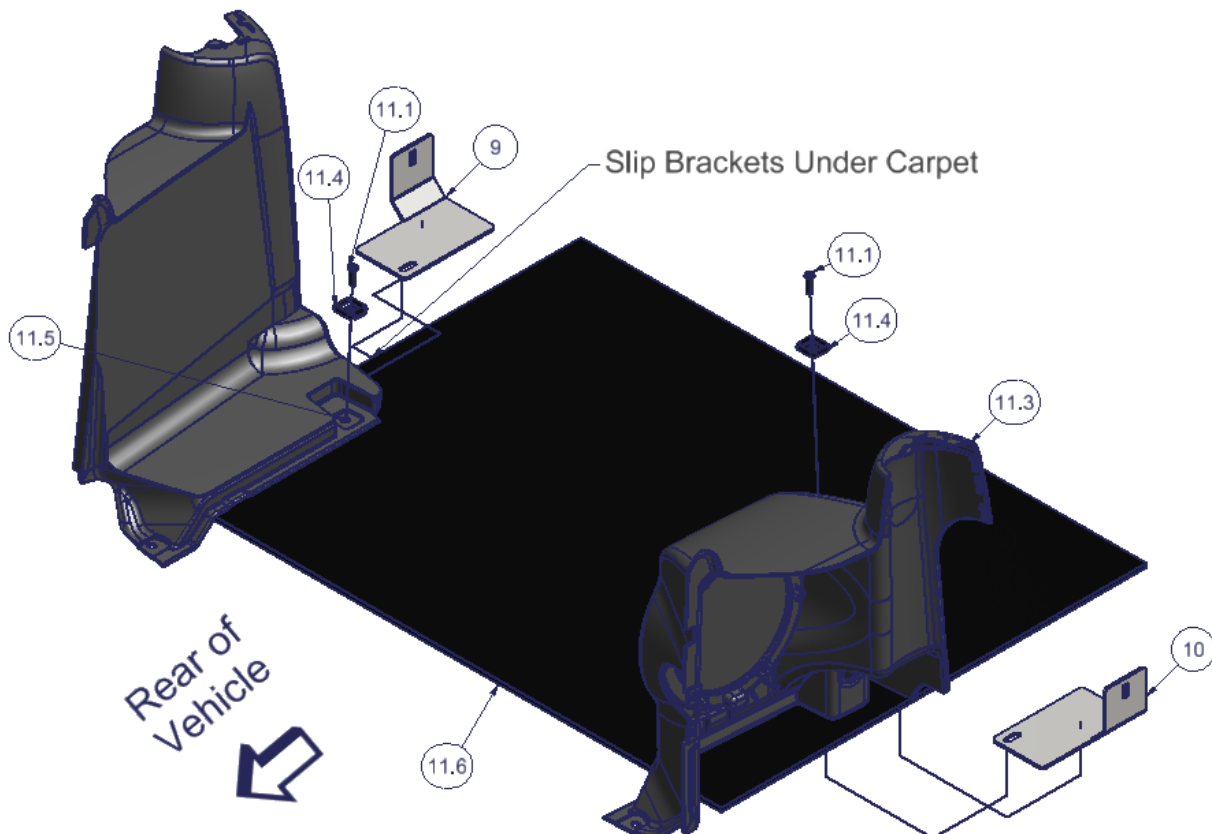

4. Position the #5 & #4 side panels by tilting the front of the panel up, then inserting the tab #11.2 on the top rear of the panel under the lip on the rear of the Jeep body. This is a tight space. Then maneuver the side panel front down to the floor while guiding it so the top front of the panel fits snugly against the roll bar assembly #11.3 & #11.5 on the vehicle. The side panels should be inboard (in front) of the mounting brackets and the bottom flush with the vehicle floor. The side panel does not rely on the deck sidewall (wheel well) to create an enclosed space. (On 2-door models the seatbelt bracket may need to be pivoted outboard as much as possible for the panel to fit). (See Figure 2)
5. Insert the #8.15 carriage bolts through the rear side of the hole in the mounting brackets. The side panels can be gently maneuvered inboard away from the mounting brackets to create room for inserting the bolt. Then, while holding the bolts in place, maneuver the panels back into position over the bolts and tighten using #8.9 washers and #8.10 wing knob nuts. The #8.15 bolt is intentionally a tight fit in the bracket slot and requires fully tightening the #8.10 wing knob nuts for it to seat. This holds the bolt in the bracket and makes it easier to remove and install the deck enclosure in the future. (The tolerance of the #8.15 carriage bolts provided can vary so find ones that fit in the slot the tightest) The #8.9 washer needs to go over the square portion of the #8.15 bolts or they will not fully tighten. (See Figure 2)

Figure 2

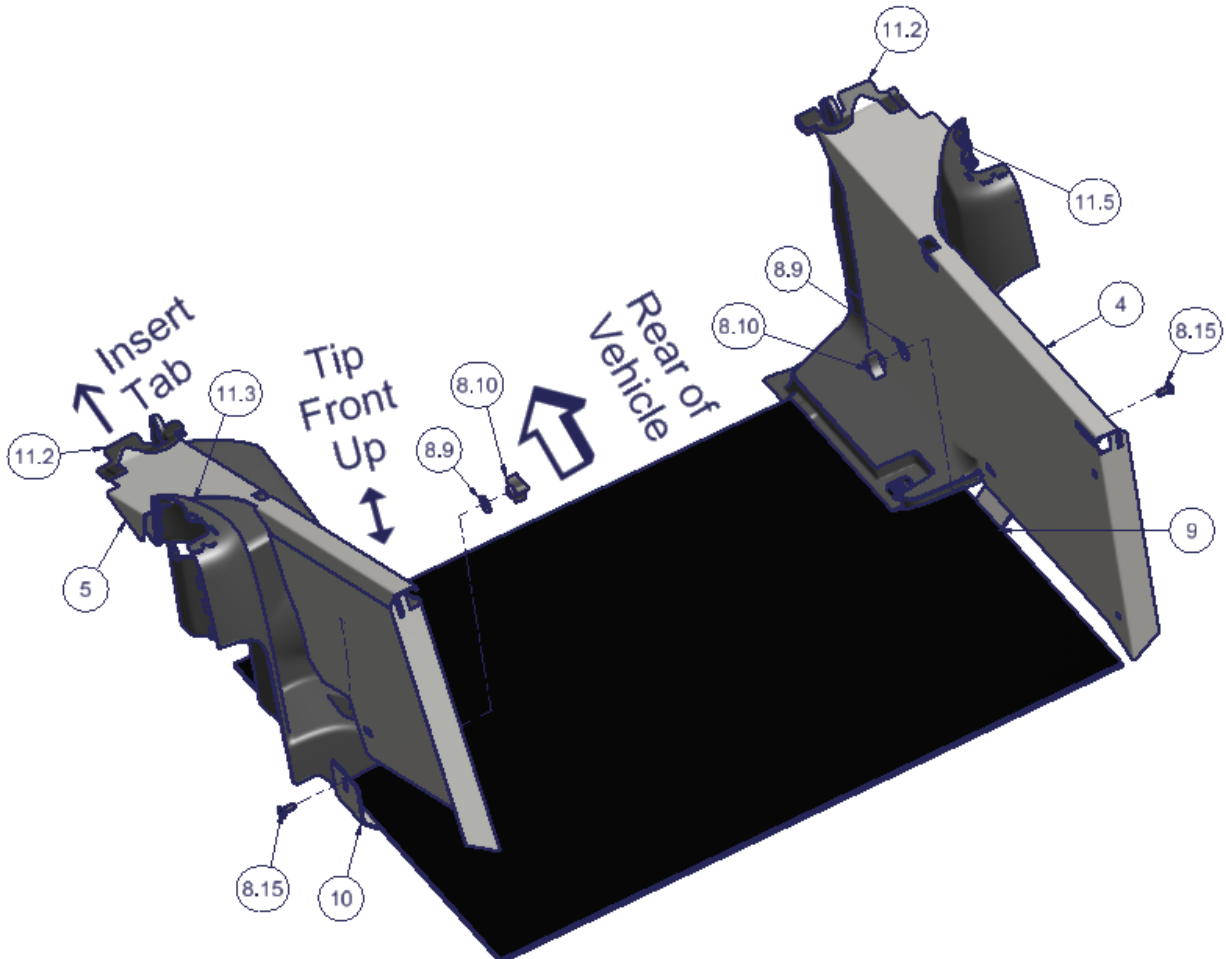
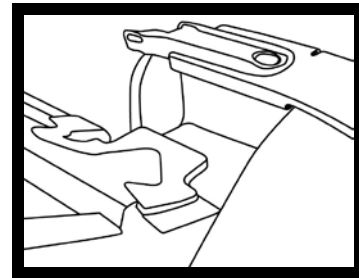
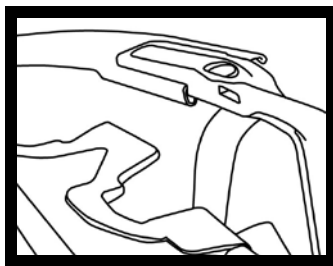

6. Install the vertical #7 Front panel using (4) #8.15 Carriage bolts, (4) #8.9 Washers and (4) #8.10 Wing Knob Nuts. The bottom should be flush with the vehicle floor. You may need to loosen the #8.10 Wing Knob nuts and/or the OEM Bolts #11.1 previously installed in the mounting brackets to allow for the adjustment of the side panels to align the holes. Tighten/re-tighten all the fasteners. The #7 front panel is vertical and not sloped upwardly toward the tailgate to allow for the 2-door rear seat to be stowed.

Figure 3

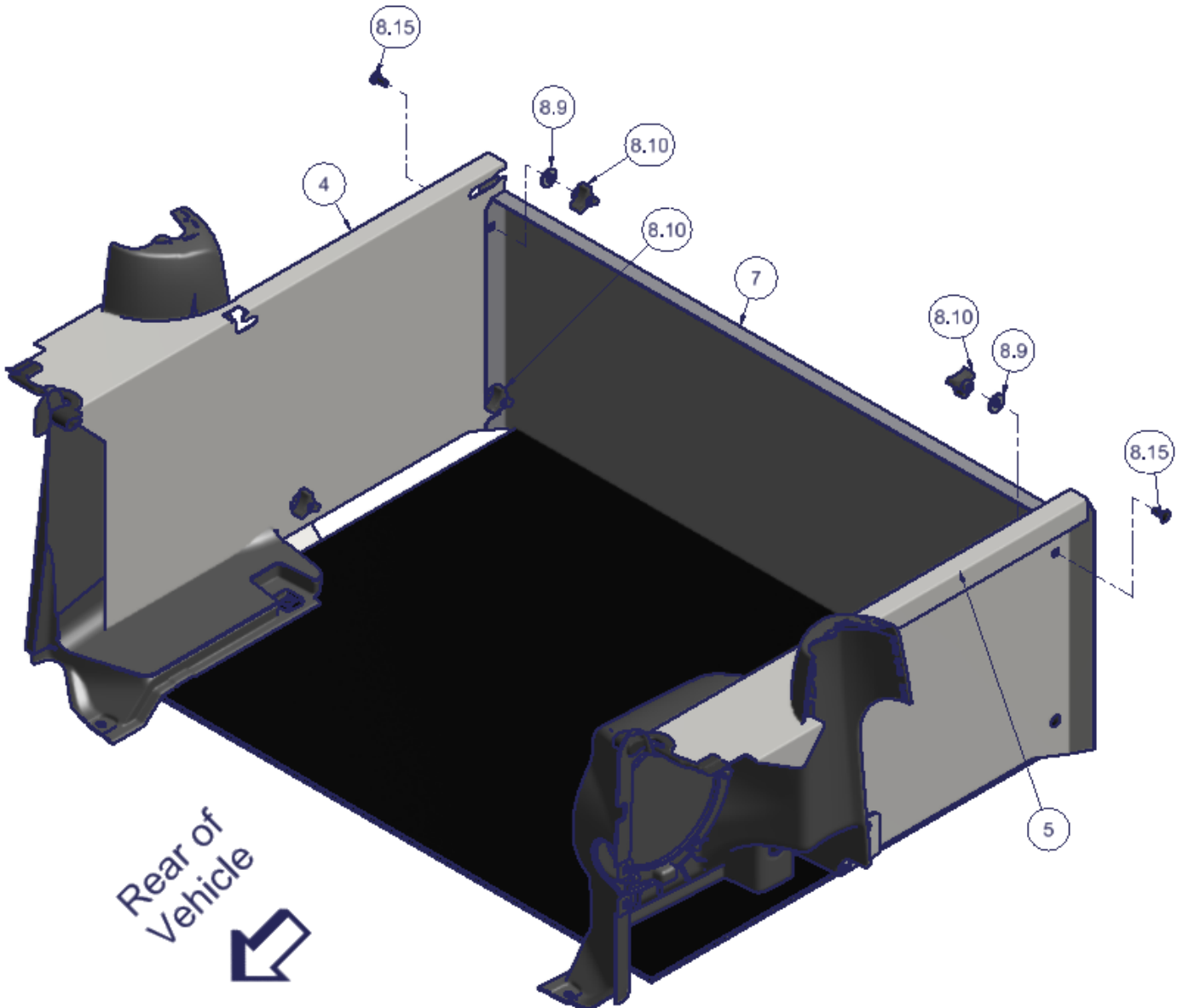

- Install #3 lid through the back of the vehicle then maneuver it so the rear is tipped up and the Front Hinging Bushings on the lid enter the openings in the front of the Tuffy side panels. Then pull the lid toward the rear of the vehicle until it stops. Close the hinged lid by maneuvering the Rear Bushings on the lid into the rear openings in the Tuffy side panels. Secure the lid shut by pushing it toward the front of the vehicle until it stops. When the vehicle tailgate is closed it prevents the lid from moving rearward to the unsecured position where it can be rotated open on the front hinging bushings. Reverse the process to either open the lid or remove it. The mounting bracket fasteners #11.1 & #8.1 can be loosened and the side panels maneuvered to fine-tune the alignment so the Lid operates smoothly. The #3 lid is not coupled to the #7 front panel. (See Figure 4 & 5)

Figure 4 (Lid Installation, Side view of Tuffy product only)

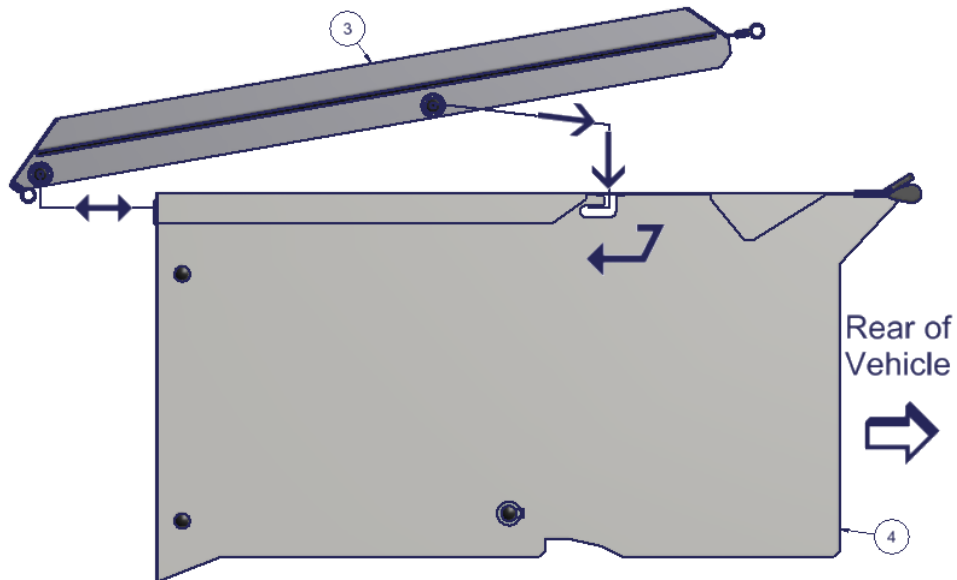
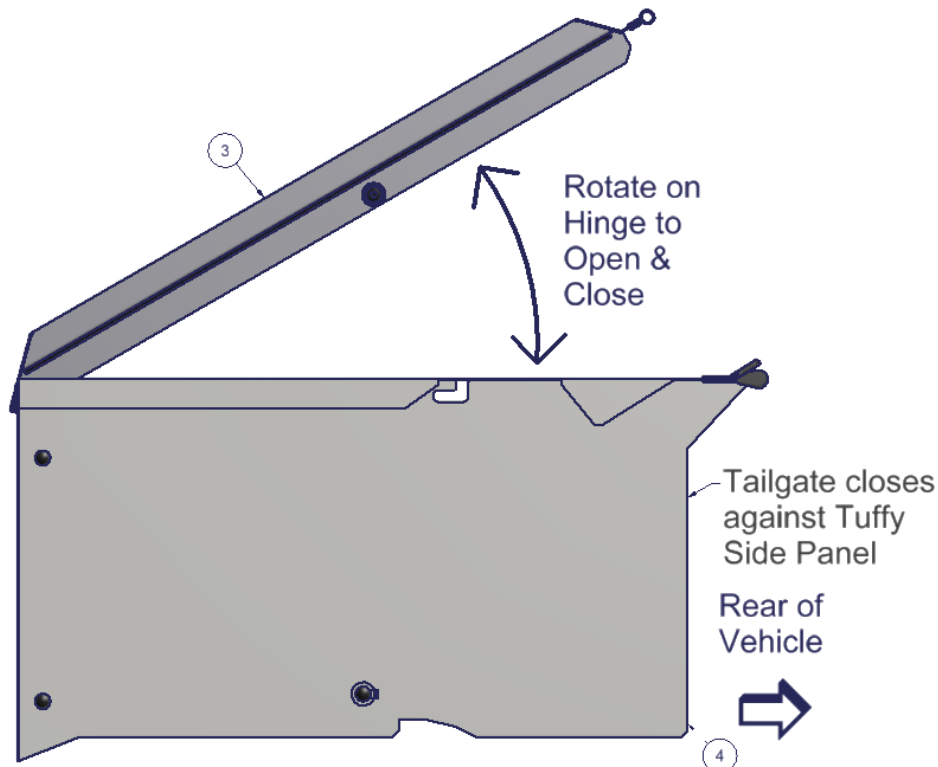

Figure 5 (Lid Operation, Side view of Tuffy product only)



Call (800)348-8339 for Technical Support