



**SUPERLIFT SUSPENSION SYSTEMS**

300 Huey Lenard Loop Rd.  
West Monroe, Louisiana 71292-9421  
Phone: (318) 322-3458  
Sales / Tech: 1-800-551-4955  
FAX: (318) 323-5995

**Superlift 3.5" lift system for 1987- 1996  
JEEP WRANGLER (YJ) 4WD  
INSTALLATION INSTRUCTIONS**

**INTRODUCTION**

Installation requires a professional mechanic. Prior to beginning, inspect the vehicles steering, driveline, and brake systems, paying close attention to the suspension link arms and bushings, anti-sway bars and bushings, tie rod ends, pitman arm, ball joints and wheel bearings. Also check the steering sector-to-frame and all suspension-to-frame attaching points for stress cracks. The overall vehicle must be in excellent working condition; repair or replace all worn parts.

**Read instructions several times before starting. Be sure you have all needed parts and know where they install. Read each step completely as you go.**

**NOTES:**

- Front / rear springs and shock absorbers (purchased separately) are also required.
- On diagrams, an arrow symbol indicates which direction is towards 'front of vehicle'.
- A foot pound torque reading ( ) is given after each appropriate fastener.
- Do not add or fabricate any components to gain additional suspension height.
- After drilling, file smooth any burrs or sharp edges or stress cracks may develop.
- Paint or undercoat all exposed metal surfaces.
- Prior to attaching components, be sure mating surfaces are free of grit, grease, undercoating, etc.

**PARTS LIST ...** The part number is stamped into each part or printed on an adhesive label. Identify each part and place the appropriate mounting hardware with it.

<b>PART NO</b>	<b>DESCRIPTION</b> (Qty.- if more than one)	<b>NEW ATTACHING HARDWARE</b> (Qty.- if more than one)
44-01-5040 .....	bracket, front track bar relocating	(1) 12 mm x 70, Gr. 10.9 bolt (1) 12 mm x 60, Gr. 10.9 bolt
44-02-5040 .....	square washer, front track bar	(2) 12 mm Stover lock nut (1) 1/2" SAE flatwasher
44-03-5040 .....	bracket, front track bar reinforcement brace	
44-04-5040 .....	bracket, rear track bar relocating	(1) 1/2" X 1-1/4" bolt (1) 1/2" x 3" bolt (2) 1/2" Nyloc nut

44-11-5040.....	bracket, rear track bar ..... relocating brace	(2) 1/2" SAE flatwasher (1) 1/2" USS flatwasher (2) 1/2" star washer (1) 11/16" OD x 9/16" ID x 1.62" sleeve (1) 3/8" x 1 " bolt (1) 3/8" Nyloc nut (1) 3/8" SAE flatwasher
44-13-5040.....	bracket, driver side front ..... brake hose relocating	(1) 1/4" x 3/4" bolt (1) 1/4" Nyloc nut (2) 1/4" SAE flatwasher
44-14-5040.....	bracket, passenger side front ..... brake hose relocating	same as driver's side
44-06-5040.....	bracket, rear brake hose..... relocating	(1) 3/8" x 1 "bolt (1) 3/8" Nyloc nut (1) 3/8" SAE flatwasher
44-12-5040.....	(2) front sway bar..... drop link	(8) Poly eye bushing halve (2) 1/8" x 2" cotter pin
10102.....	(4) 1/2" x 2 3/4" x 6" round..... U-bolt	(8) 1/2" fine Nyloc nut (8) 1/2" extra thick flatwasher
55-16-5040.....	(2) transfer case drop bracket .....	(6) 1/2" x 3" allen head bolts
5342.....	(2) front or rear spring eye..... bush. kit; enough for one pair	(4) large OD Poly eye bushing halve (4) small OD Poly eye bushing halve (2) inner sleeve, 1/2" ID (2) inner sleeve, 9/16" ID
44-05-5040.....	(3) bump stop contact bracket for all but driver/ rear location	
44-10-5040.....	bump stop contact bracket for driver / rear location	
0034.....	Superlift badge .....	alcohol wipe pad
00461.....	decals, "Warning To Driver"	

**FRONT PROCEDURE****1) PREPARE VEHICLE...**

- Prior to placing the front of vehicle on jack stands (performed in next step), remove the stock sway bar drop links. The links (one per side) connect the anti-sway bar body to the U-bolt plates.
- To dislodge the links' upper ends, which are tapered studs, use hammer strikes to the bar body near the link-to-body attaching point. Do not strike the stud.
- With the transmission in neutral, raise front of vehicle with a pneumatic bumper jack or two floor jacks positioned on either side of the front axle. Place jack stands under the frame rails directly behind the front springs' rear hangers. Lower the frame onto the stands. Put vehicle in gear or "park", set emergency brake and chock rear tires. Remove front tires, wheels, and shocks

**2) TRACK BAR / BRAKE HOSES...**

- Detach the bottom end of track bar from its axle mounting bracket then tie bar up and out of the way.
- The upper end of the front brake hoses attach to the top of each frame rail with one Torx bolt located directly behind the shock towers. Remove the bolts; access is gained through the engine department.

**3) FRONT SPRINGS...**

- Remove the four front spring-to-axle U-bolts. Take care since they will be reused unless optional U-bolts were purchased.

**NOTE:** The remainder of spring removal and installation is performed one side at a time:

- On the driver's side, position a floor jack beneath the axle tube, just inboard of the leaf spring. Raise the jack until the axle just separates from the spring. Now, detach the spring from its hangers.
- Prior to installation, thoroughly lubricate the new spring eye bushings and sleeves with a water resistant, Lithium based grease. Loosely attach the spring to its hangers; snug-up but do not completely tighten the mounting bolts yet. Note that the large diameter eye takes the larger diameter sleeve and installs at the stationary mount, opposite the pivoting shackle end.
- Repeat the spring removal and installation procedure on the passenger's side.

**4) U-BOLTS...**

- Make sure the the spring perches and the the springs are clean and free of any debris.
- Position the front axle onto the springs being sure the tie bolt heads align and seat into the spring perch holes.

- While installing the front U-bolts, locate one #44-05-5040 bump stop bracket onto the top of the axle tubes. Diagram 3 shows how the bump stops are captured by the U-bolts. Note that only the driver's side / rear bump stop is held in place by two U-bolts. The other three bump stops are captured by one single U-bolt. When tightening the U-bolts (1 00), keep the bracket positioned so that when the suspension compresses, the stock bump stop will contact the top of the bracket flush, not at an angle. Use an "X" tightening sequence when torquing the U-bolts.

- [DIAGRAM 1] The front track bar relocating bracket and hardware installs as per Diagram 1. Before tightening the bracket-to-axle bolt, be sure that bracket position is perfectly vertical, not leaning to either side. The bar-to-bracket bolt is not installed until a later step, when vehicle weight is on the suspension.

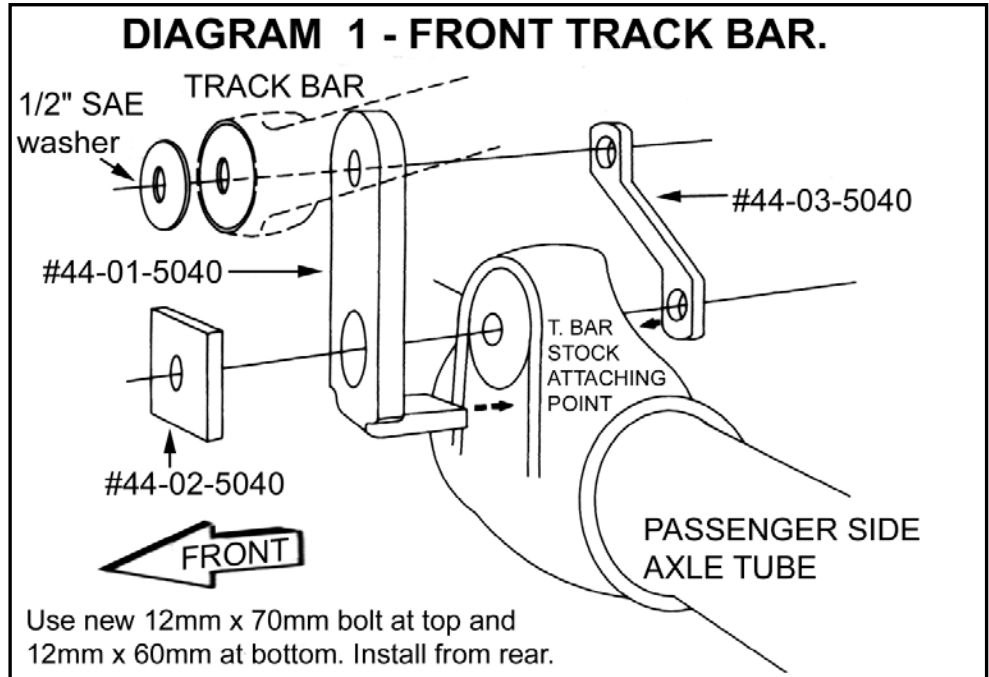

- Install front shock absorbers. Tighten upper stem type mounts only until bushings swell slightly then torque lower mounts (45).

5) **BRAKE HOSES...**

- If Superlift extended length brake hoses are being used, install now as per separate instructions. If the stock hoses are retained, install the Superlift relocating brackets as per Diagram 2. Note that there is a driver (#44-13-5040) and a passenger side (#44-14-5040) bracket.

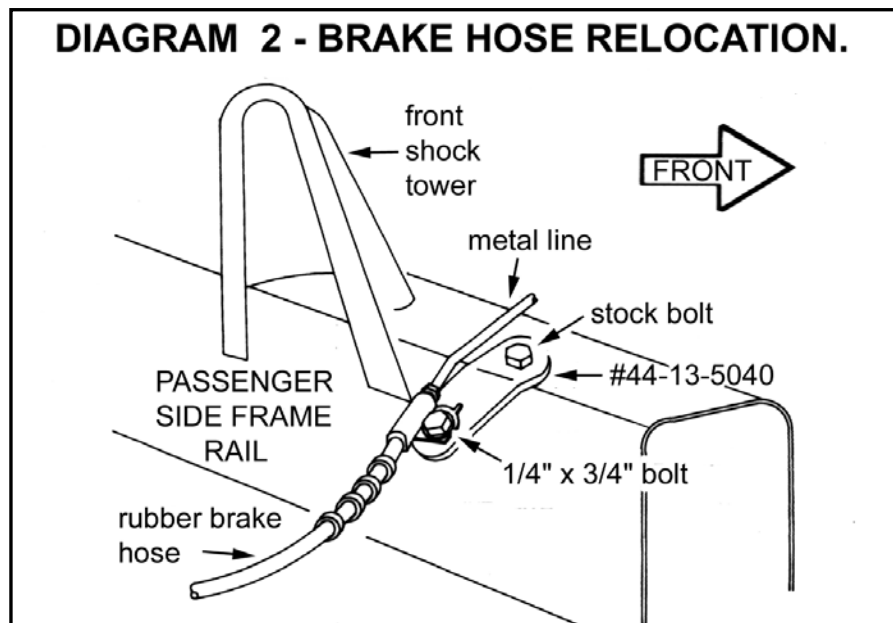

**6) TRACK BAR / FRONT FASTENER TIGHTENING ...**

- Install tires / wheels (80-110), remove jack stands and lower vehicle to floor.
- Tighten the front springs' shackle (95) and stationary (105) ends.
- Attach the bottom end of the track bar to the Superlift bracket (99) using the hardware shown in Diagram 1. It may be necessary to turn the steering wheel slightly either left or right to achieve bolt-to-bracket alignment.

**7) SWAY BAR LINKS...**

- Lubricate the sway bar drop link eye Poly bushings, then insert them into the new links' eyes. Remove the tapered studs, found at the top of the stock links, and insert into the new links. Tighten the top and bottom link ends (45) then insert new cotter pins.

**REAR PROCEDURE****8) PREPARE VEHICLE...**

- Raise rear of vehicle and place jack stands beneath frame rails, directly in front of rear springs' front hangers. Lower the frame onto the stands, then chock front tires. Remove rear tires / wheels and shocks.

**9) BRAKE HOSE...**

- If Superlift extended length brake hose is being used, install now as per separate instructions. If not, remove the retainer clip that attaches the stock rubber brake hose to its upper mounting bracket. This is where the rubber hose ends and the metal line starts. Insert the new "Z" shaped bracket (#44-06-5040) in between the stock mounting bracket and the hose end. The 3/8" hardware is used at the bracket-to-bracket end. Position the hose / line through the slot and into the hole on the "Z" bracket's opposite end, then reinstall clip.

**10) TRACK BAR REMOVAL...**

- Unbolt the bottom end of the track bar from the driver side of the rear axle and tie it up and out of the way.

**11) SPRING REMOVAL / INSTALLATION...**

- Remove rear U-bolts.
- Lubricate and install the spring eye bushings and then the springs using the same procedures used at front of vehicle. Note that the thick end of the spring degree shims (already attached to the springs) should point towards front of vehicle. Again, do not fully tighten spring eye bolts yet. This is performed in a later step.

**11) BUMP STOP BRACKETS...**

- Make sure the spring perches and the springs are clean and free of any debris.
- Position the front axle onto the springs, being sure the tie bolt heads align and seat into the spring perch holes.

- ☐☐ As with the front end, the compression travel bump stops are held in place on top of the axle tubes by the U-bolts. On the passenger side, one single U-bolt captures #44-05-5040 bump stop. For the driver side, bump stop #44-10-5040 has "lips" on both sides and is captured by both U-bolts. Torque new rear U-bolts, flatwashers and Nyloc nuts (90) using an "X" tightening sequence.

**12) TRACK BAR BRACKET #44-04-5040...**

- ☐ [DIAGRAM 3 and 3a] Position bracket #44-04-5040, with its slotted hole to the top, onto the stock track bar-to-axle mount, as shown the diagrams.
- ☐ First, loosely install the 3/8" hardware, then the spacer sleeve and 1/2" lower bolt. Now tighten the hardware in the same order. The bar and brace are installed in a later step.

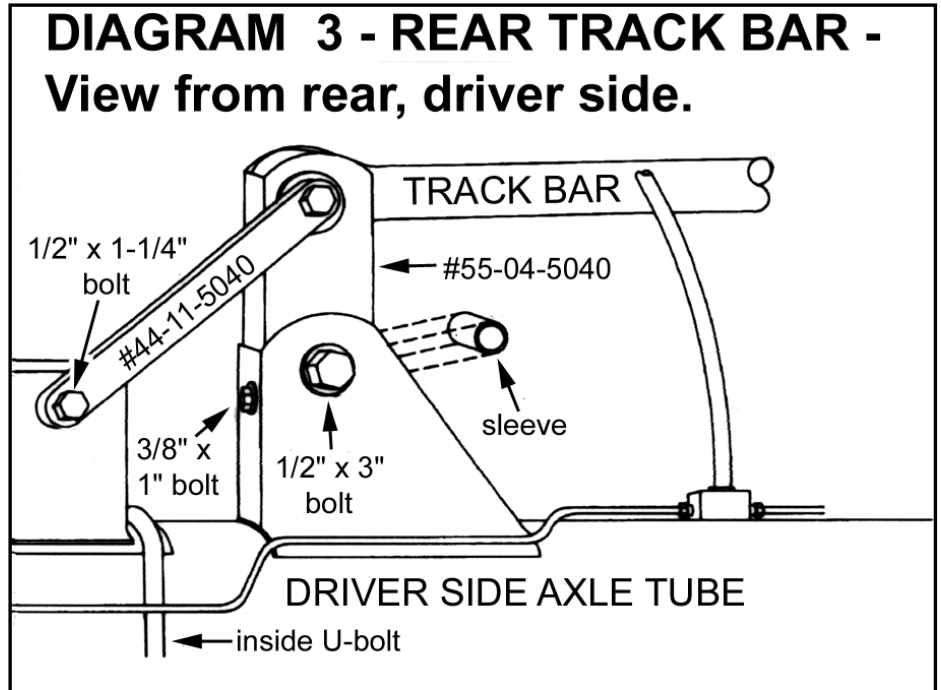

**13) SHOCKS...**

- ☐ Install shocks, torquing upper and lower mounts (45).

**NOTE:** Some models may exhibit light contact between the shock body and axle tube. Because the contact is light, it does not affect the performance of the suspension or the shock. If this is unacceptable, your options are: (A) use a smaller body shock (B) relocate shock brackets.

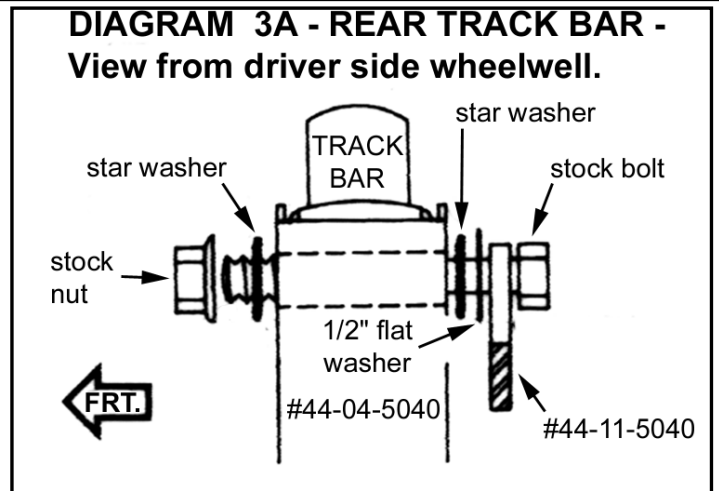

**14) TIRES / WHEELS...**

- ☐ [DIAGRAM 4] Tighten the lug nuts (80-110) in the sequence shown.

**WARNING:** When the tires / wheels are installed, always check for and remove any corrosion, dirt, or foreign material on the wheel mounting surface, or anything that contacts the wheel mounting surface (hub, rotor, etc.). Installing wheels without the proper metal-to-metal contact at the wheel mounting surfaces can cause the lug nuts to loosen and the wheel to come off while the vehicle is in motion.

**WARNING:** Retighten lug nuts at 500 miles after any wheel change, or anytime the lug nuts are loosened. Failure to do so could cause wheels to come off while vehicle is in motion.

- Lower vehicle to the floor.

**15) REAR FASTENER TIGHTENING SEQUENCE...**

- Manually bounce the front and rear suspension several times to "seat" the springs.
- Tighten the rear springs' shackle (95) and stationary (105) ends.

**16) REAR TRACK BAR BRACE...**

- Attach the bottom end of the track bar to the Superlift bracket with brace # 44-11-5040 and additional hardware positioned onto the stock bolt as shown in Diagram 3. The bolt locates itself in the slot and the star washers help secure it there. Snug-up, do not torque, the bar-to-bracket bolt, then position the lower end of brace onto the bump stop bracket.
- With the brace properly located, drill a 1/2" hole into the bump stop through the existing hole in the brace. Install furnished 1/2" hardware (57) at the new hole and torque the stock upper bolt (99).

**17) LOWERING THE TRANSFER CASE...**

- [Diagram 5] There are two or three bolts, towards the skid plate's center, that tie the transfer case to the plate. Loosen, but do not remove these bolts.

- Position a floor jack beneath the skid plate and slightly load the jack. On each side, remove the 3 skid plate-to-frame bolts and lower the assembly enough to insert the #55-16-5040 drop brackets.

- Note that the spacers' concave surface mates against the plate. Install the supplied 1/2" x 3" allen-head bolts. Now tighten the skid plate (30) and transfer case mount bolts (33).

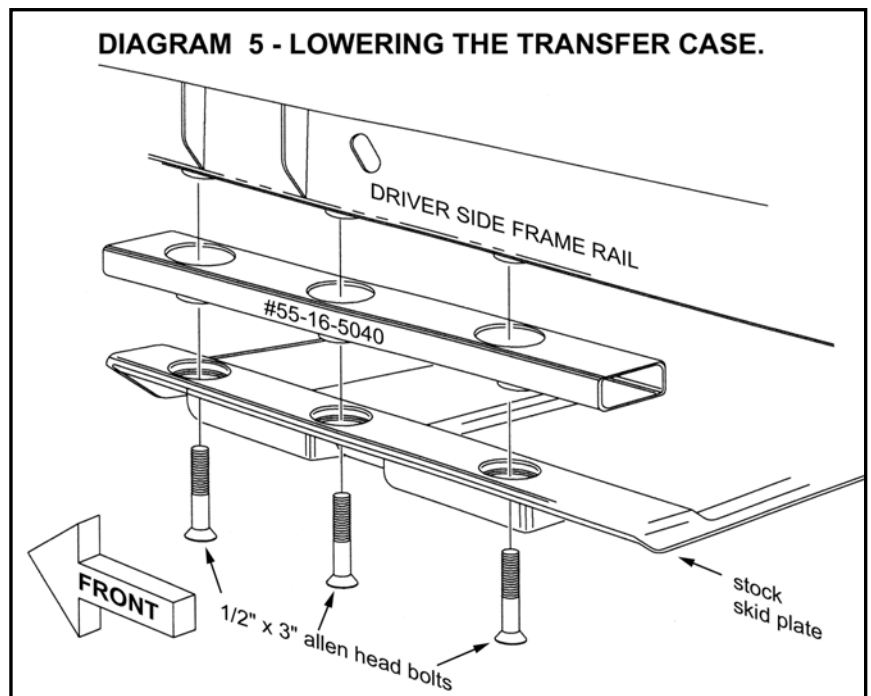
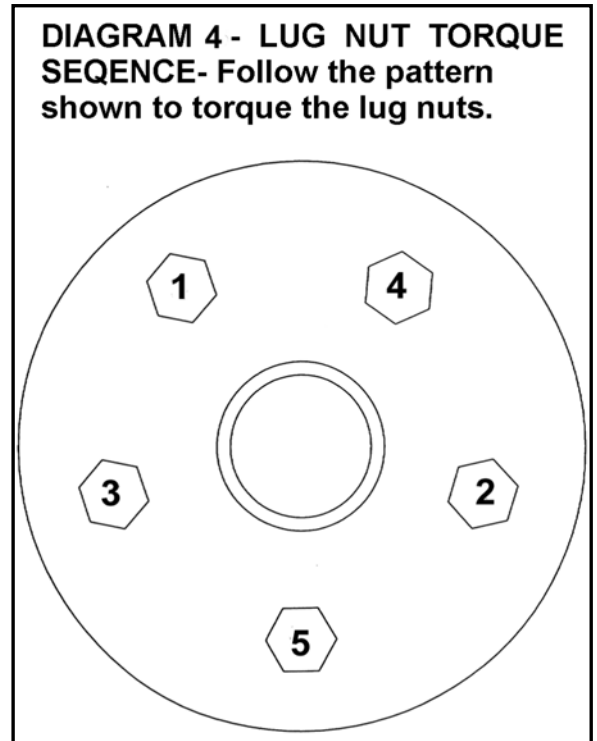

**NOTE:** Lowering the skid plate assembly can affect transmission shifting functions. Refer to the appropriate MANUAL or AUTOMATIC instructions:

**MANUAL TRANSMISSION** - When shifting into Reverse, check for clearance between the stick and floor pan. If there is interference, trim away the pan as required. Normally, no more than 1/4" of material must be removed. Also, it may be necessary to move the center console rearward slightly. If so, the stock self-tapping screws can be reused.

**AUTOMATIC TRANSMISSION** - The engine should crank only if the vehicle is in Park or Neutral. The transmission's shift linkage must be readjusted if the vehicle cranks in one but not both positions, or if it will crank in any other position. If adjustment is required, it must be performed by a qualified Jeep technician.

**18) FINAL PROCEDURES AND TORQUE CHECK...**

- With the front tires pointing perfectly straight ahead, the steering wheel cross bars will be misaligned. To center the steering wheel, loosen the two clamp bolts on the drag link adjustment sleeve and rotate the sleeve until the desired steering wheel position is achieved. Then tighten the clamp bolts (33).
- Cycle steering lock-to-lock and inspect steering, suspension and driveline systems for proper operation, tightness, and adequate clearance. If brake hose fittings were touched, recheck them for leaks. Be sure all hoses / wiring are of adequate length. Now, raise vehicle again and reposition jack stands. With the suspension unloaded and "hanging", repeat the above inspection procedures.

**NOTE:** With some vehicles, engine torque, while under heavy loads, can cause the transfer case to make contact with the rear lip of the skid plate. If this occurs, space the rear of the plate down further by adding one or two washers per side to the top of the rear spacers.

**19) Activate four wheel drive system and check front hubs for engagement**

**20) HEADLIGHTS...**

- Readjust headlights to proper setting.

**21) SUPERLIFT NAME BADGE AND WARNING DECAL...**

The system includes one 2" x 5" name badge (#0034). Additional and / or larger badges are available from Superlift or a Superlift dealer. We suggest putting the badges on the front fenders, tailgate, or rear window. The badge mounts by means of factory applied, double-backed tape. Follow these instructions to ensure that badge sticks properly:

- Clean designated area with warm, soapy water. Rinse and wipe dry with a soft, lint free towel.
- Thoroughly prep the area with the furnished alcohol wipe pad and wipe dry with a soft, lint free towel. Do not touch the surface again with your hands; they transfer body oils.
- Remove mounting tape backing, line up badge, and press in place. Do not touch mounting tape or allow tape to get dirty.



- Press firmly on the badge face and hold a few seconds to seat mounting tape. A superior adhesive bond forms over time. We recommend allowing 24 hours of cure time before washing and waxing. The emblem itself can be cleaned with any glass cleaner.
- Install the WARNING TO DRIVER decal on the inside of the windshield, or on the dash, within driver's view. Refer to the "NOTICE TO DEALER AND VEHICLE OWNER" section below.

## 22) ALIGNMENT...

- Front end alignment has not been affected by this system, but we suggest that alignment be checked to improve tire wear characteristics and driveability.

### IMPORTANT PRODUCT USE INFORMATION

As a general rule, the taller a vehicle is, the easier it will roll over. Offset, as much as possible, what is lost in roll over resistance by increasing tire track width. In other words, go "wide" as you go "tall". Many sportsmen remove their mud tires after winter / hunting season and install ones more appropriate for street driving; always use as wide a tire and wheel combination as possible to enhance vehicle stability.

We strongly recommend, because of roll over possibility, that the vehicle be equipped with a functional roll bar and cage system. Seat belts and shoulder harnesses should be worn at all times. Avoid situations where a side rollover may occur.

Generally, braking performances and capabilities are decreased when significantly larger / heavier tires and wheels are used. Take this into consideration while driving.

Do not add, alter, or fabricate any factory or aftermarket parts to increase vehicle height over the intended height of the Superlift product purchased. Mixing component brands is not recommended.

Most states have some type of law limiting vehicle height. The amount of lift allowed, and how the lift may be achieved, varies greatly. Several states offer exemptions for farm or commercially registered vehicles. It is the owner's responsibility to check state and local laws to ensure that their vehicle will be in compliance.

Superlift makes no claims regarding lifting devices and excludes any and all implied claims. Superlift will not be responsible for any altered product or any improper installation or use of our products.

We will be happy to answer any questions concerning the design, function, and correct use of our products.

### IMPORTANT MAINTENANCE INFORMATION

It is the ultimate buyer's responsibility to have all bolts / nuts checked for tightness after the first 100 miles and then every 1000 miles. The steering, suspension and driveline systems, along with wheel alignment should be inspected by a qualified professional mechanic at least every 3000 miles.

### NOTICE TO DEALER AND VEHICLE OWNER

Any vehicle equipped with a Superlift lifting device must have the enclosed "Warning to Driver" decal installed on the inside of the windshield or on the vehicle's dash, within driver's view. The "Warning to Driver" decal is to act as a constant safety reminder for whoever may be operating the vehicle. The WARRANTY IS VOID unless this decal is in place. **INSTALLING DEALER...** It is your responsibility to install warning decal and forward these installation instructions to the vehicle owner for review of warnings, product use and maintenance information. Replacement warning decals are available free upon request.

These instructions are to be kept with the vehicle registration papers and owners manual for the service life of the vehicle.

**SUPERLIFT LIMITED LIFETIME WARRANTY**

Suspension products bearing the Superlift (LKI Ent.) name are warranted for as long as the original purchaser owns the vehicle that the LKI product was originally installed on. This warranty is non-transferable. Warranty covers only the product, no labor, time loss, or freight incurred. Any product that has been abused, altered, incorrectly installed, or used in competition is not covered. Product finish, spring bushings, Polyurethane products, and normal wear is not covered. The LKI product is subject to replacement or repair. No other warranties are expressed or implied. An authorized Superlift dealer must inspect the part in question and confirm that the "Warning to Driver" decal is properly displayed. A copy of the sales invoice is required for warranty consideration.