



BESTOP

2 Piece Soft Door Kit Installation Instructions

For: Toyota Land Cruiser FJ40

Part Number: 51774

1964 - 1984 (Soft Doors Only, Top Kit not included)

DO NOT INSTALL THIS PRODUCT ON ANY VEHICLE OTHER THAN THOSE LISTED ABOVE.



WARNING

This product is designed to enhance the appearance of the vehicle and to shield the occupants from ordinary weather conditions. Do not rely in any way on the components of this product to contain occupants within the vehicle, or to protect against injury or death in the event of an accident. This product will not protect the occupants from falling objects. Never operate vehicle in excess of manufacturer's specifications.

WEAR SEAT BELTS AT ALL TIMES

Read and follow, precisely, all installation instructions provided when installing this product. Failure to do so may result in a poor fit and could place occupants of the vehicle in a potentially dangerous situation. Failure to properly install or reinstall this product may cause the product or a component part to come off the vehicle, potentially causing an accident and possible injury to the occupants of the vehicle. After installing or reinstalling the product, check to make sure it has been properly installed.

Installation Tips

Before you begin installing this door assembly, read all instructions thoroughly. After completing the installation, keep these instructions for further reference. Below are a few tips to make this installation easier.

For a smooth fit:

It is normal for the fabric to contract and wrinkle when stored in the shipping carton. Within a few days after the installation, the fabric will relax and the wrinkles will disappear.

Parts List and Hardware Identification

Door, Upper - Right Qty - 1
 Door, Upper - Left Qty - 1
 Door, Lower - Right Qty - 1
 Door, Lower - Left Qty - 1

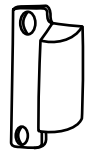

Door Striker, Part Number 256.30, Qty - 2

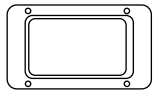

Paddle Handle - Door, Part Number 245.46, Qty - 2

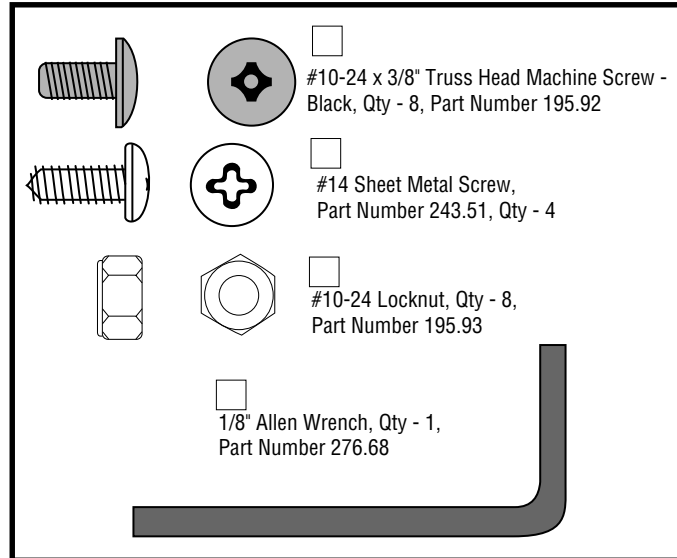

Tools Needed

Adjustable Wrench	Drill Motor
Pencil	3/16" Drill Bit
Phillips Screwdriver	Center Punch
Light Weight Oil	Safety Glasses



Caution

Safety glasses should be worn at all times while installing this product.

Hardware Installation

Step One

WINDSHIELD ADJUSTMENT

Measure and record the distance from the top inside edge of the windshield to the top outer edge of the vehicle body. Take the measurement from approximately six inches inside the vehicle's doors. Check to make sure that both sides measure equally. To install this top properly, this measurement must be 81".

Adjust your windshield by loosening the Windshield Clamps and adjusting the brackets. You may then lean the windshield forward or back as necessary. Use a shim to fix the windshield in place if it remains loose after you tighten the screws.

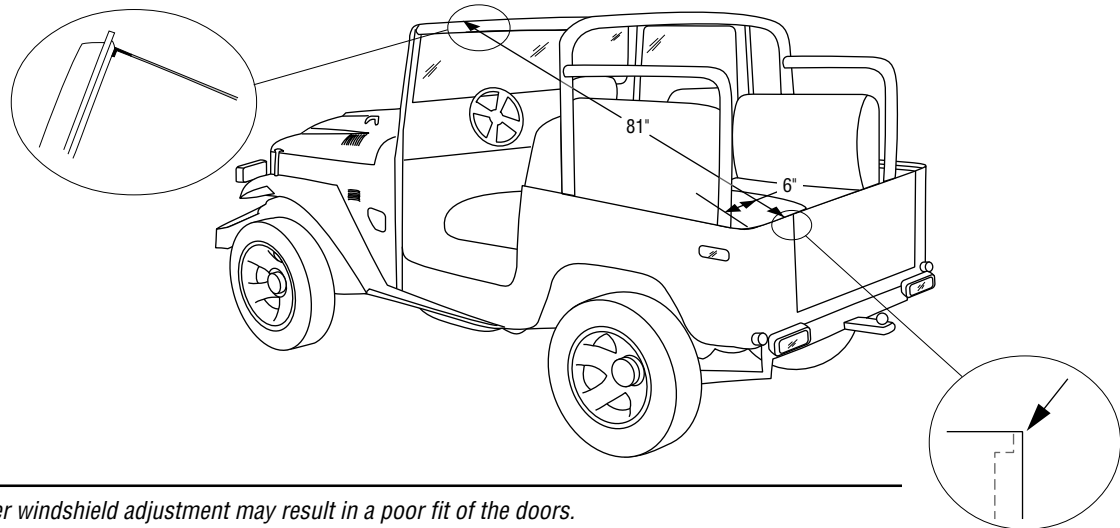

Note: This is a very important step in the installation process. Improper windshield adjustment may result in a poor fit of the doors.

Step Two

INSTALL PADDLE HANDLES

Locate the pre-cut "X" in the lower door panel where the Paddle Handle will fit into the mounting plate on the door frame. Fold the pre-cut fabric back and insert the Paddle Handle into the mounting plate so that the latch mechanism is inside of the vehicle. Align the four holes in the Paddle Handle Assembly with the four holes in the mounting plate. Use a pointed tool to punch four holes in the fabric to match the holes in the Paddle Handle and the mounting plate. Insert four #10-24 Truss Head Machine Screws from the outside and secure them with #10-24 Locknuts. Do not fully tighten the screws at this time. Trim the excess fabric around the Paddle Handle. Repeat for both lower doors.

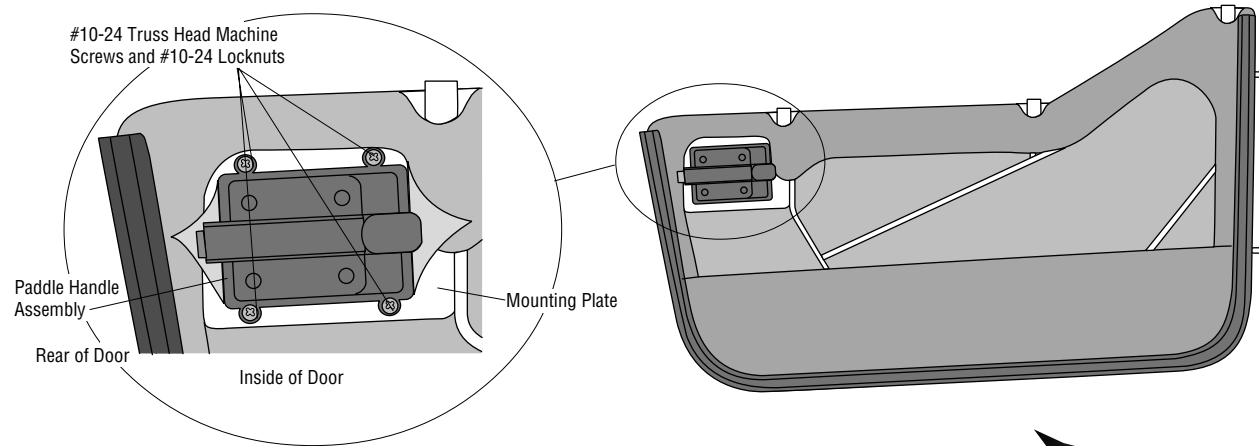

Step Three

INSTALL LOWER DOORS

Hold the door straight out from the vehicle with the hinge pins over the body hinges. Lower the pins into the hinges. Make sure that the pins are fully inserted into the body hinges. Close the door and check all sides to make sure that it fits properly against the body.

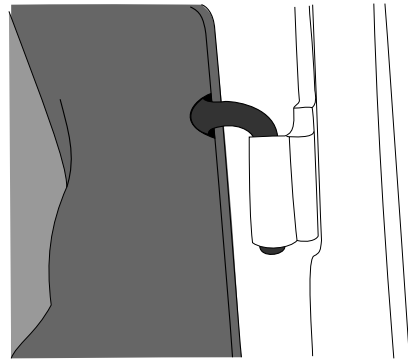

Note: Remove the black protective covers from the pins before installing the doors.

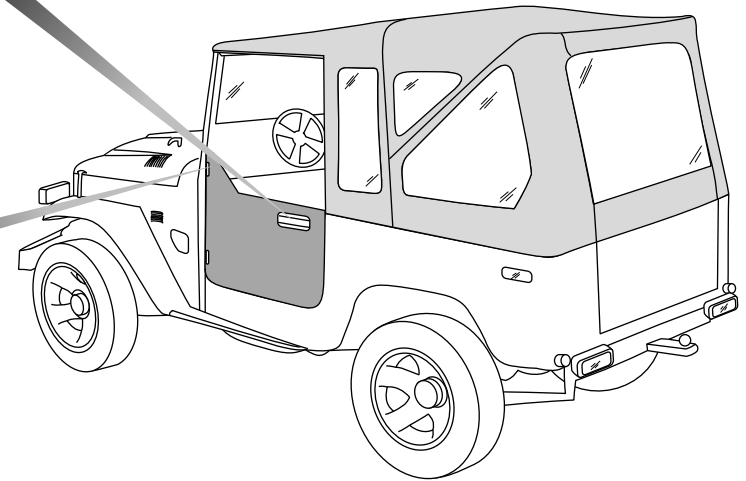

Step Four

INSTALL DOOR STRIKERS

Close the door against the body and place a Door Striker on the body aligned with the Paddle Handle Latch. Mark the center of the slots in the striker. Center punch the marks and drill a 3/16" hole at each location. Use two #14 Sheet Metal Screws to install the Door Striker. The Door Strikers may be adjusted in or out until you are satisfied with the way the door shuts and opens. Tighten the #10-24 Truss Head Machine Screws on the Paddle Handle. You may need to adjust the paddle handle to improve the fit. Repeat this for the other door.

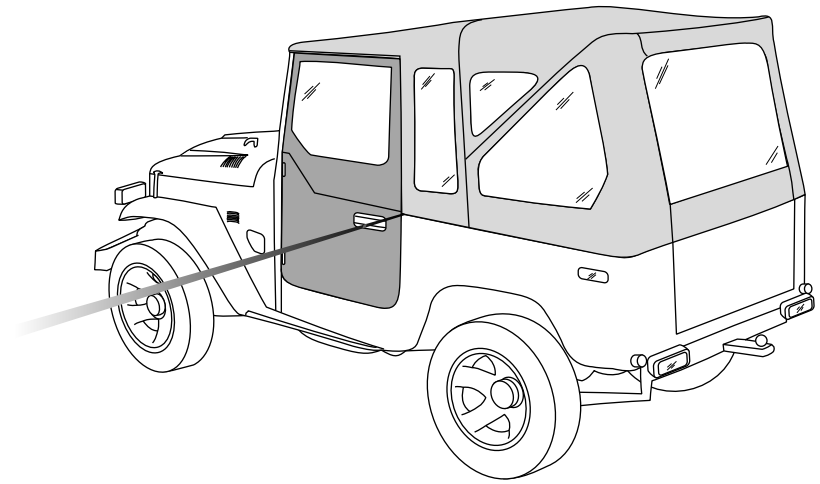
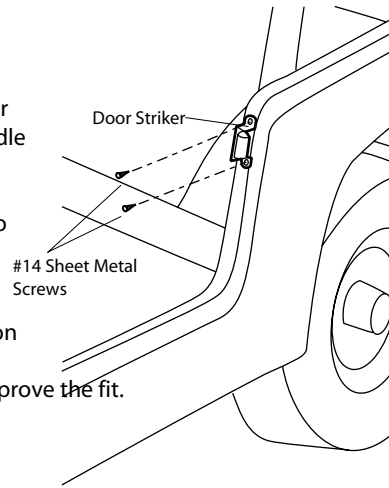

Note: If a hard door striker is present, it must be removed.

Note: Some vehicles will use the existing holes and bolts from the hard door striker.

Step Five

Install the upper door into the lower door. Starting with the front pin, slip the pins into the sockets in the lower door. Make sure that the pins are well seated in the sockets. Close the door to check that it fits properly against the body. If necessary, use the 1/8" Allen Wrench, provided in the parts kit, to loosen the Collars on the front and rear upper door pins. The Collars will slide up or down as needed to provide the best fit of the Upper Door against the windshield. Attach the loop strip on the bottom of the upper door to the hook strip on the top of the lower door. If necessary for proper door fit, bend the door slightly.

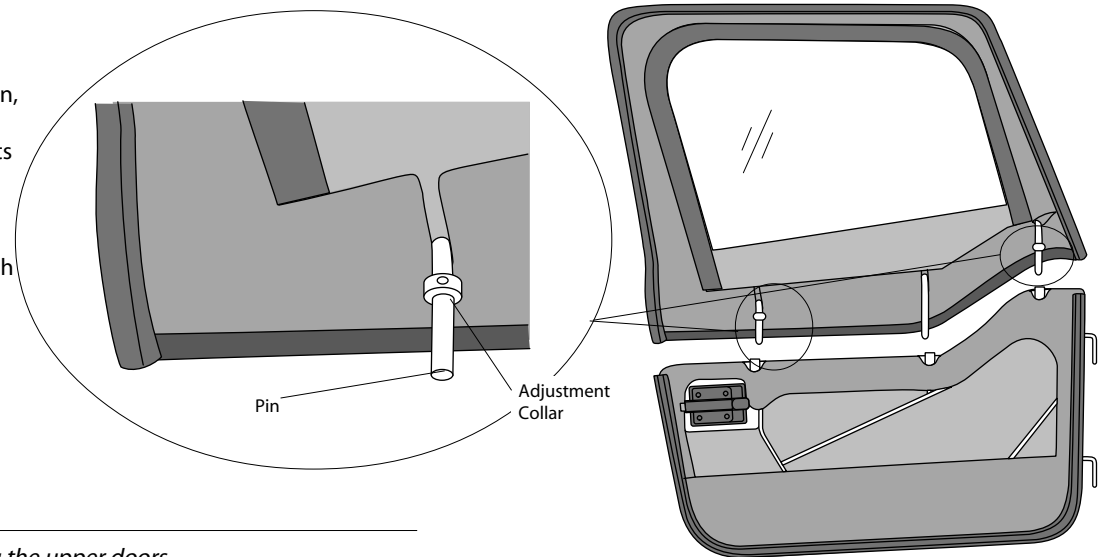

Note: Remove the red protective covers from the pins before installing the upper doors.

Note: Lubricating the upper door pins with a light weight oil will make it easier to install and remove the upper door.

Care and Maintenance of your New Doors

Your doors are made of the finest materials available. To keep it looking new and for the maximum possible wear, it will need periodic cleaning and maintenance.

Washing: The fabric should be washed often using soap, warm water and a soft bristle brush. Rinse with clear water to remove all traces of soap.

Windows: Keep windows clean to avoid scratching. **DO NOT** use a brush on the windows! Wash with a watersoaked cloth or sponge and a mild dishwashing detergent. **NEVER WIPE THE WINDOWS WHEN THEY ARE DRY.** Be careful when cleaning snow or frost from the vinyl windows since they are easily scratched and may crack at low temperatures. **DO NOT** roll the window in cold weather. The windows become stiff and will crack.

Zippers: Keeping the zipper cleaned and lubricated with a silicone lubricant will help prevent damage and keep the zippers in a smooth working condition. If a zipper opens behind the slider, the slider may have been spread apart. This problem can usually be repaired by using an ordinary pair of pliers to bring the sides back into parallel. Return slider to the normal Open position.

Squeeze lightly at first and test the zipper. If the zipper continues to remain open squeeze more firmly with the pliers and try the zipper again. Repeat this procedure until the zipper operates correctly.

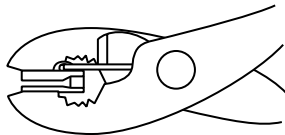
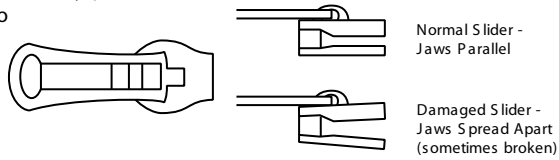

Water: In the event of seeping through the seams, 3M Scotchgard™ may be applied on the inside of the seams to stop the seepage.

Rips in the fabric may be repaired with Bondex™ iron on patches. Iron the patches to the Inside of the fabric, carefully following the Bondex™ instructions.

LIMITED WARRANTY

We warrant our product to be free from defects in material and workmanship, for the terms specified below, provided there has been normal use and proper maintenance. This warranty applies to the original purchaser only. All remedies under this warranty are limited to the repair or replacement of any item or items found by the factory to be defective within the time period specified.

If you have a warranty claim, first you must call our factory at the number below for instructions. You must retain proof of purchase and submit a copy with any items returned for warranty work. Upon completion of warranty work, if any, we will return the repaired or replaced item or items to you freight prepaid. Damage to our products caused by accidents, fire, vandalism, negligence, misinstallation, misuse, Acts of God, or by defective parts not manufactured by us, is not covered under this warranty.

THE WARRANTY TIME PERIOD IS AS FOLLOWS: ALL SOFT GOODS MANUFACTURED BY OUR COMPANY (USING PRIMARILY VINYL, PLASTICS, AND/OR FOAM): ONE YEAR FROM DATE OF PURCHASE.

ANY IMPLIED WARRANTIES OF MERCHANTABILITY AND/OR FITNESS FOR A PARTICULAR PURPOSE CREATED HEREBY ARE LIMITED IN DURATION TO THE SAME DURATION AND SCOPE AS THE EXPRESS WRITTEN WARRANTY. OUR COMPANY SHALL NOT BE LIABLE FOR ANY INCIDENTAL OR CONSEQUENTIAL DAMAGE.

Some states do not allow limitations on how long an implied warranty lasts, or the exclusion or limitation of incidental or consequential damages, so the above limitations or exclusions may not apply to you.

This warranty gives you specific legal rights, and you may also have other rights which vary from state to state.

For further information please contact:

Bestop Inc.
Customer Service
(800)346-3910
(303)465-1755