

JKS™

Installation Instructions

Product: **B1 Body Lift™**

Part Number: **PN 9904**

Application: **Wrangler TJ, 1997+**

Welcome

CONGRATULATIONS on your purchase of a new JKS B1 Body Lift! At JKS Manufacturing, we are committed to providing you with the best products available and your satisfaction is our first priority.

PLEASE READ these Installation Instructions carefully, and save them for future reference, as they contain important installation and maintenance information.

Important

INSTALLATION OF JKS MOTOR LIFT in conjunction with B1 Body Lift is recommended. This will make installation steps 1, 2, 5, 6, and 7 unnecessary.

BODY LIFT MUST BE INSTALLED on one side of vehicle at a time.

Tools Required

- Metric/Standard Socket Wrench Set
- Torque Wrench
- Tape Measure
- Medium Strength Threadlocker
- Spray Lubricant (WD-40 or similar)
- Hydraulic Floor Jack
- Sturdy Block of Wood (to protect body)
- Center Punch and Hammer
- 1/4" Drill Bit
- Reciprocating Saw or Die Grinder with Cut-Off Wheel (for trimming fan shroud)
- Factory Service Manual (recommended)

** Asterisk denotes tools that are not required for some applications. Thoroughly read instructions first to determine which tools will be required for your application.*

Parts



	DESCRIPTION	QTY
A	Dura-Thane™ Body Puck	11
B	1/2" x 4-1/2" Bolt	6
C	1/2" Flat Washer	6
D	7/16" x 4" Bolt	5
E	7/16" Flat Washer	5
F	1/4" x 3/4" Bolt	2
G	1/4" x 1" Fender Washer	1
H	1/4" Nylock Nut	6
I	Pivot Bushing Drop Plate	1
J	Extended Radiator Bumper	2



ATTENTION INSTALLER

SKIP STEPS 1, 2, 5, 6, AND 7 IF
INSTALLING A 1" MOTOR MOUNT LIFT IN
CONJUNCTION WITH BODY LIFT

Installation

1. REMOVE FAN AND SHROUD

- Remove the four bolts holding the fan shroud to the radiator.
- Remove the four nuts holding the fan to the water pump pulley.
- Remove the fan shroud and fan from vehicle.

2. REMOVE T-CASE LINKAGE BRACKET

- Pull the carpet away from the floor pan on driver side of vehicle to expose the four bolts holding the transfer case shift linkage bracket.
- Remove the four mounting bolts from the transfer case shift linkage bracket, and remove the linkage rod from the attached pivot bushing from beneath the vehicle.
- Remove the transfer case shift linkage bracket.
HINT: Mark bracket to indicate correct position for re-installation.

3. LOOSEN BODY MOUNTS

- Locate all eleven body mount bolts on vehicle. Refer to the BODY MOUNT LOCATION DIAGRAM for assistance.
- Loosen each body mount bolt, but DO NOT REMOVE until instructed.
- Remove the bolt from body mount ① located beneath the grill.
- Remove the bolts from body mounts ②, ③, ④, ⑤, and ⑥ on DRIVER SIDE of vehicle only.
HINT: Body mount ⑤ is located between fuel tank and upper rear shock mount.

4. INSERT BODY PUCKS

- Position a hydraulic jack between body mounts ③ and ④ on DRIVER SIDE of vehicle.
- Place a sturdy wooden block between the hydraulic jack pad and channel portion of vehicle body for protection.
- Carefully raise the vehicle body just enough to insert the 1.25" Body Pucks (A) between body and factory body mounts ②, ③, ④, ⑤, and ⑥.

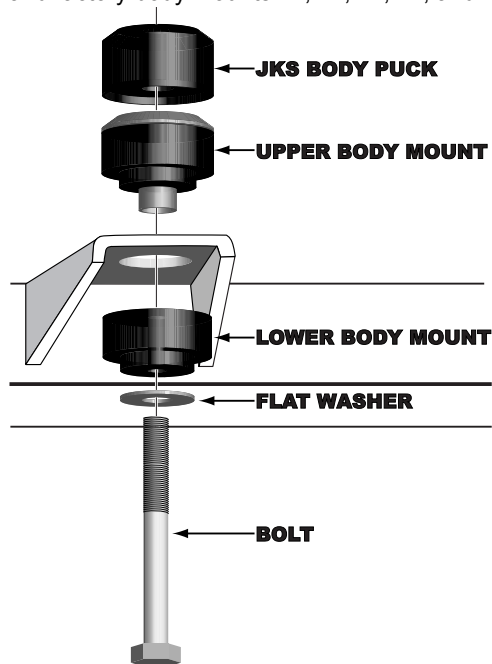

HINT: Position Body Pucks as pictured, with recessed bottom encapsulating the factory body mount.

- With Body Pucks (A) inserted, slowly lower the vehicle body onto mounts, ensuring correct alignment of body on chassis.
- Apply medium strength thread locking compound to three of the supplied 1/2" x 4-1/2" Bolts (B) and two of the 7/16" x 4" Bolts (D).
- First insert the 7/16" x 4" Bolts (D) with 7/16" Flat Washers (E) into body mount positions ⑤ and ⑥. Next insert the 1/2" x 4-1/2" Bolts (B) with 1/2" Flat Washers (C) into body mount positions ②, ③, and ④. Start threads but DO NOT TIGHTEN bolts until instructed.

- Repeat this procedure with body mounts ②, ③, ④, ⑤, and ⑥ on the PASSENGER SIDE of vehicle.
- Insert the last remaining Body Puck (A) at body mount ① located beneath the grill.
- Apply medium strength thread locking compound to the last remaining 7/16" x 4" Bolt (D) and insert with a 7/16" Flat Washer (E) into body mount position ①.
- Using a torque wrench, tighten all 1/2" and 7/16" Bolts (B & D) to 30-35 ft-lbs.
HINT: Use care when tightening bolts to avoid crushing factory rubber body mounts.

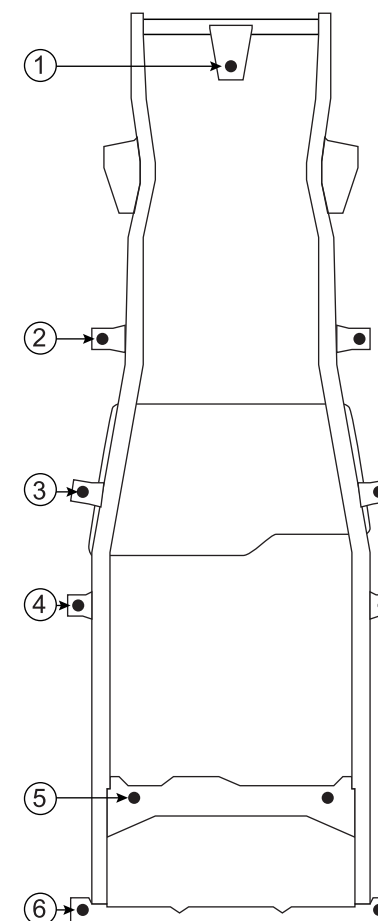

BODY MOUNT LOCATION DIAGRAM

5. MODIFY RADIATOR

- Locate the four fan shroud mounting holes on the radiator.
- Measure exactly 1" below the factory mounting holes and mark the location with a center punch.
HINT: *The lower passenger side hole will line up with an existing factory hole and will not require marking with a center punch.*
- Drill a new 1/4" hole through the three center punched marks.

6. MODIFY FAN SHROUD

It will be necessary to trim the fan shroud to clear the lower radiator hose before mounting.

- Test fit the fan shroud to the radiator by aligning with the new mounting holes.
- Mark the location where the lower radiator hose interferes with the fan shroud.
- Trim the fan shroud until it completely clears the radiator hose when mounted to the radiator.
- Check for interference between the fan shroud and fan blades, or any other objects, and trim the fan shroud accordingly.
- Re-install the fan using the original hardware, and mount the fan shroud to the new mounting holes in radiator.
- Secure the fan shroud to the radiator with four of the 1/4" Nylock Nuts (H) provided. Use the supplied 1/4" x 1" Fender Washer (G) at the existing lower passenger side hole in radiator.

7. MODIFY T-CASE SHIFT LINKAGE

It will now be necessary to modify the transfer case shift linkage bracket that you removed in step 2.

- Remove the pivot bushing from the shift linkage bracket by removing the two mounting bolts.
- Install the supplied Pivot Bushing Drop Plate (I) to the shift linkage bracket using the original pivot bushing mounting bolts as shown.

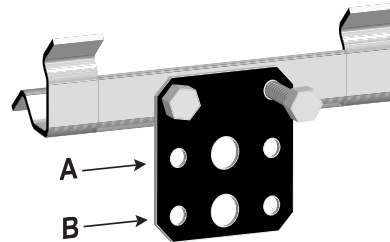

- Install the pivot bushing onto the Drop Plate (I) using the supplied 1/4" x 3/4" Bolts (F) and remaining two 1/4" Nylock Nuts (H). Refer to the list below for the correct mounting holes to use for your application.

Motor Mount Lift?	T-Case Lowering Kit?	
No	Yes	Use hole "B"
Yes	Yes	Use hole "A"
No	No	Use hole "A"
Yes	No	Do not use Drop Plate

- Slide the linkage rod through the relocated pivot bushing and re-install the shift linkage bracket to the floor pan using the original mounting hardware.
- Check operation of the shift lever to ensure the transfer case fully engages all ranges.
HINT: *If necessary, adjust linkage between shift lever and bell crank. If interference is experienced, it may be necessary to trim the floor to provide sufficient clearance.*

8. REPLACE RADIATOR BUMPERS

- Remove the factory rubber bumpers from the underside of the grill panel.
- Apply a spray lubricant to the supplied Extended Radiator Bumpers (J). Insert into original mounting holes and use a twisting motion to install.



HINT: *If the factory inverted U-bracket pictured above restricts radiator bumper installation, it must be removed. Remove bracket by cutting from chassis using a suitable cutting tool.*

9. POST-INSTALLATION

- Check all mounting hardware to ensure it has been correctly installed and tightened to factory torque specifications.
- Check torque specifications for all mounting hardware after driving vehicle 50 miles, and after first time off-road.

Maintenance

Check all torque specifications as part of regular vehicle maintenance schedule.

© 2006 JKS Manufacturing, Inc & Aftermarketing, LLC
Revision Date 10/6/2006