

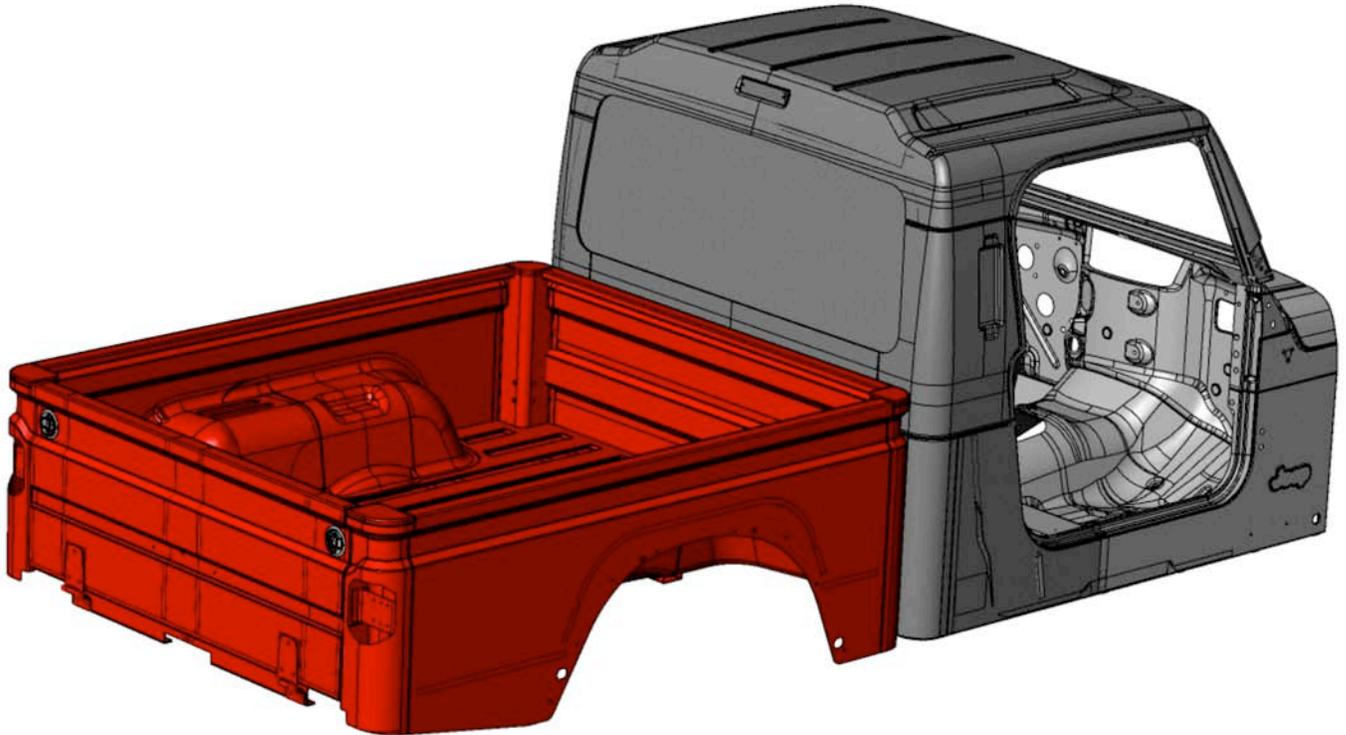

AMERICAN EXPEDITION
VEHICLES

BRUTE KIT

04. The Brute Bed



Installation Guide



A M E R I C A N E X P E D I T I O N
V E H I C L E S

PLEASE READ BEFORE YOU START

TO GUARANTEE A QUALITY INSTALLATION, WE RECOMMEND READING THESE INSTRUCTIONS THOROUGHLY BEFORE BEGINNING ANY WORK. THESE INSTRUCTIONS ASSUME A CERTAIN AMOUNT OF MECHANICAL ABILITY AND ARE NOT WRITTEN OR INTENDED FOR SOMEONE NOT FAMILIAR WITH AUTO BODY REPAIR.

Required Tools

Drill Motor

4" Angle Grinder

Tape Measure

Appropriate Safety Equipment

Common Hand Tools

Spring Loaded Center Punch or Equivalent

File or Die Grinder



A. PAINTING THE BED AND TAILGATE ASSEMBLIES

OVERVIEW

The Brute bed is delivered as an assembled unit requiring no fabrication. The bed will need to be prepared and painted. Preparation of the bed includes smoothing exterior spot welds and seam sealing all the seams.

Minor assembly of the bed consists of:

- Installation of the fender flares
- Installation of the ground strap
- Installation of an optional spray-in urethane bed liner.
- Installation of the stock taillights.

Minor assembly of the tailgate is required and involves:

- Bolting the tailgate to the bed.
- Installation the tailgate latches and bed support cables.
- Installation of the license plate bracket.

The Bed assembly, once painted will be mounted to the frame and aligned with the rest of the body. This process is easy but can be time consuming to achieve a perfect fit. We generally allow two hours for alignment and any shimming if required.

INSTRUCTIONS

1. Install the hinges to the tailgate using the supplied hinges and hardware provided in the Brute Hardware pack. The tailgate is now ready for paint prep and paint.
2. Drill any required holes. If you are planning on drilling any holes and or trimming the wheel openings for the AEV Highline Body Kit, bed tie downs, or any other accessory, now is the time.
3. Using the FUSOR 123 or equivalent catalyzed seam sealer, tape, seal and sand all exterior seams.
4. Prepare all spot welded areas for a light skim coat of autobody filler. Block, prime, seal and paint per autobody collision repair standards. If you are planning on using a spray-in bed liner, there is no reason to paint the inside. We recommend bringing the spray-in



A M E R I C A N E X P E D I T I O N
V E H I C L E S

liner up over the rails and down the outside approximately 5/8 to 3/4 inches to line up with the horizontal exterior seam in the corners of the bed.

5. It is acceptable to seam seal the exterior seams on the front of the bed and not finish out the spot welds.



B. INSTALLATION OF THE BRUTE BED

OVERVIEW

DO NOT MOUNT THE TAILGATE TO THE BED UNTIL THE BED HAS BEEN MOUNTED, AND THE ENTIRE BODY ALIGNED AND BOLTED DOWN INTO FINAL POSITION.

INSTRUCTIONS

1. Insert the six rubber bed mounts. Use the two supplied in the Brute Hardware pack along with the four rear most stock body mounts as shown.
2. Place the bed onto the frame, be especially careful at the rear of the bed where it fits around the rear crossmember. Roughly align the unit by eye.
3. Run a piece of heavy utility string along the bodyline on both sides of the vehicle from the rear corner of the bed onto the door line and up as far as the cowl. This will allow you to stand at the front of the vehicle and “Gunsight” the bodyline down the side to align the cab and bed. This is a time consuming process as you will have to adjust the bed and the closeout separately to achieve perfect results. We typically allow for two hours for this process. Use a jack and block of wood to lift the rear of the cab if necessary. You may have to use large washers between the body mounts and the body in order to level everything out.
4. Once you have everything in alignment, weld the rear body mounts to the cab. Bolt the body mount and isolator to the body and weld in place.
5. Install the 3” spacers into the middle body mounts. Tighten all body mounts.
6. Install the Ground strap from the exhaust hanger bolt to the bed crossmember directly above the middle exhaust hanger.
7. Install the latches and cables onto the tailgate. The inside portion of the latch must be trimmed approximately 0.5” in order to fit into the inner portion of the tailgate. Bolt the cables on so that the “ear” on the cable ends directs the cable to fold downward when the gate is closed. **DO NOT OVERTIGHTEN THE CABLE BOLTS. THEY MUST BE ABLE TO SWING FREELY.**
8. Install the rubber bumpers into the tailgate tabs on the bed.



A M E R I C A N E X P E D I T I O N
V E H I C L E S

9. Bolt the tailgate to the bed using the supplied hardware and nut plates. Center the tailgate so that the gaps are even on both sides and the gate is level at the bodylines with the bed. Design gap on either side is 0.2”.
10. Install the license plate bracket. Wire the LED light to the stock tailgate connectors from the CHMSL in the donor vehicle.
11. Install the flares and taillights from the donor vehicle.



A M E R I C A N E X P E D I T I O N
V E H I C L E S

COMMENTS OR QUESTIONS?

American Expedition Vehicles

Phone: 406.251.2100

Email: tech@aev-conversions.com

Website: <http://www.aev-conversions.com>