







# Installation Instructions Lower Cargo Rack Bracket

## Application:

- Jeep Wrangler  
2003 – Current  
Part Number: 41437

[www.Bestop.com](http://www.Bestop.com) - We're here to help! Visit our web site and click on "[Ask a Question](#)". Click here for more [Jeep Accessories by Bestop](#).

INSTALLATION TIME	SKILL LEVEL	
 <b>45 Minutes</b>	 <b>2 - Moderately Easy</b>	
TOOLS		
 Phillips Screwdriver #2	 Wrench 7/16" and 1/2"	 Safety Glasses



 **CAUTION** Safety glasses should be worn at all times while installing this product.

 **WARNING** This product is designed primarily to enhance the appearance of the vehicle and to shield the occupants from ordinary weather conditions. Do not rely in any way on the components of this product to contain occupants within the vehicle, or to protect against injury or death in the event of an accident. This product will not protect the occupants from falling objects. Never operate the vehicle in excess of manufacturer's specifications.

### WEAR SEAT BELTS AT ALL TIMES

Read and follow, precisely, all installation instructions provided when installing product. Failure to do so may result in a poor fit and could place occupants of the vehicle in a potentially dangerous situation.

# Lower Cargo Rack Bracket Installation Instructions

## Parts List and Hardware Identification

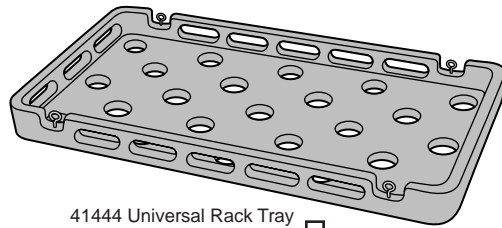

41444 Universal Rack Tray  
(Sold Separately), Qty - 1

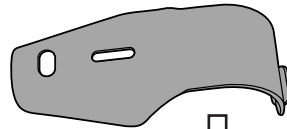

Vertical Mount Bracket, Qty - 2,  
Part Number 387.66

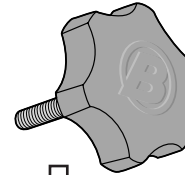

Knob, Qty - 4,  
Part Number 374.54

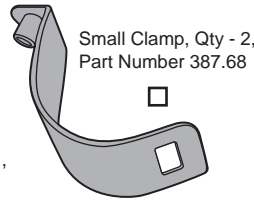

Small Clamp, Qty - 2,  
Part Number 387.68

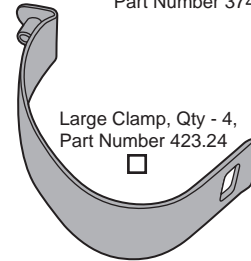

Large Clamp, Qty - 4,  
Part Number 423.24

Front Load Bar, Qty - 1,  
Part Number 387.70

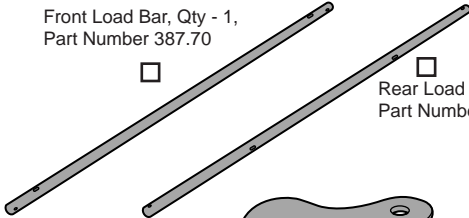

Rear Load Bar, Qty - 1,  
Part Number 387.71

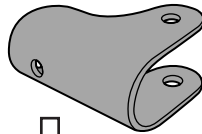

Pivot Bracket, Qty - 2,  
Part Number 387.69



Vertical Bar, Qty - 2,  
Part Number 387.72

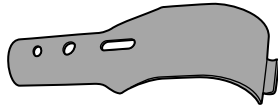

Horizontal Mount Bracket,  
Qty - 2, Part Number 387.67

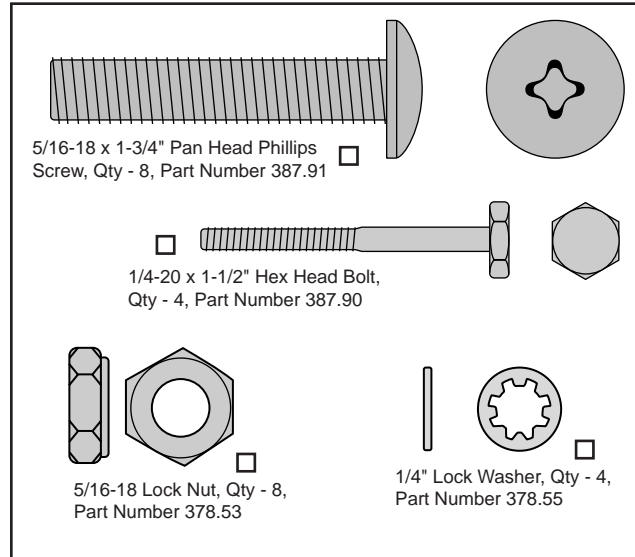

5/16-18 x 1-3/4" Pan Head Phillips  
Screw, Qty - 8, Part Number 387.91

1/4-20 x 1-1/2" Hex Head Bolt,  
Qty - 4, Part Number 387.90

5/16-18 Lock Nut, Qty - 8,  
Part Number 378.53

1/4" Lock Washer, Qty - 4,  
Part Number 378.55

## 1 Install Horizontal Mount Brackets on Rear Load Bar

The Rear Load Bar is the one that has the slots located closest together. Place the Horizontal Mount Brackets on each end of the Rear Load Bar. Use the hole nearest the end of the bracket if you are installing on a 1992 - 1995 Wrangler. Use the second mounting hole if you are installing on a 1997 - 2002 Wrangler. Use a 5/16-18 x 1-3/4" Pan Head Screw and a 5/16-18 Lock Nut for each Horizontal Mount Bracket.

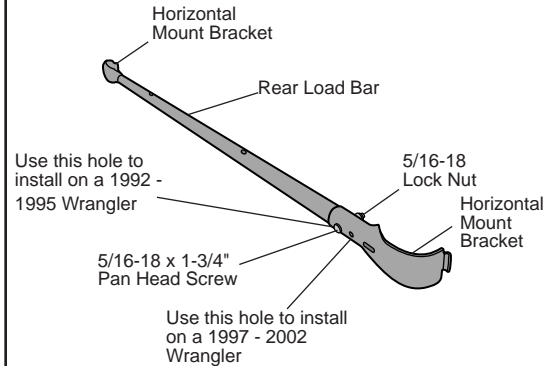

## Lower Cargo Rack Bracket Installation Instructions

### 2 Install Pivot Bracket and Vertical Mount Bracket on Vertical Bar

Place a Pivot Bracket on one end of each Vertical Bar. Install a 5/16-18 x 1-3/4" Pan Head Screw and 5/16-18 Lock Nut and tighten securely. Then place a Vertical Mount Bracket on the other end of each Vertical Bar. Loosely install a 5/16-18 x 1-3/4" Pan Head Screw and 5/16-18 Lock Nut in each bracket.

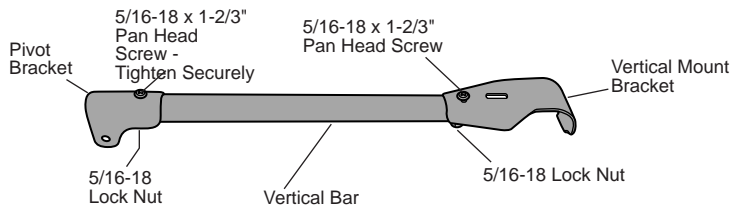

### CAUTION

DO NOT overtighten the bolts that attach the Pillars to the Tray. This may strip the aluminum inserts in the Tray.



### 3 Install Rear Load Bar on Tray Assembly

Orient the Rear Load Bar Assembly on the bottom of the Tray over the attachment points next to the long side of the tray. The Horizontal Mount Brackets should angle away from the Tray. If they do not, flip the bar end over end. Secure the Load Bar with two 1/4-20 x 1-1/2" Hex Bolts and two 1/4" Lock Washers.

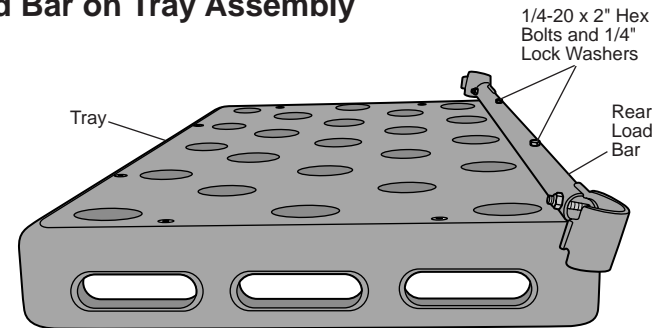

Hold the Lock Washers while tightening the bolts so that they don't fall into the slot.



### CAUTION

DO NOT overtighten the bolts that attach the Pillars to the Tray. This may strip the aluminum inserts in the Tray.

### 4 Install Front Load Bar on Tray Assembly

Orient the Front Load Bar Assembly on the bottom of the Tray over the attachment points next to the short side of the tray. Secure the Load Bar with two 1/4-20 x 1-1/2" Hex Bolts and two 1/4" Lock Washers.

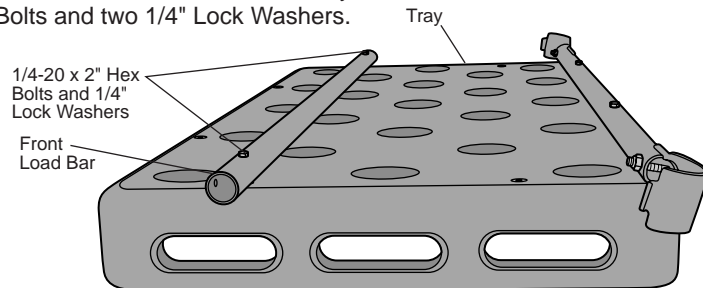

Hold the Lock Washers while tightening the bolts so that they don't fall into the slot.



### 5 Install Vertical Bar Assemblies

Loosely attach the Pivot Brackets on the Vertical Bar Assemblies to the ends of the Front Loader Bar. Use a 5/16-18 x 1-3/4" Pan Head Screw and a 5/16-18 Lock Nut for each Vertical Bar Assembly.

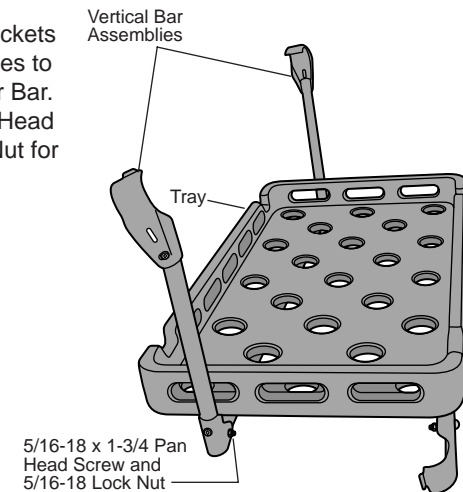

## Lower Cargo Rack Bracket Installation Instructions

### 6 Install Tray Assembly

Hook the Vertical Mount Brackets around the horizontal part of the sport bar and hook the Horizontal Mount Brackets around the back of the vertical sport bar leg so that the Tray is level.

Use a Knob and Large Clamp to secure each Vertical Bracket to the sport bar.

For 2003 - 2006 Wranglers, use a Knob and Large Clamp to secure each Horizontal Bracket and for 2007 and Newer Wranglers, use the Small Clamp.

Place the slot in the Clamp over the hook on each Mount Bracket and wrap the Clamp around the sport bar. Insert the shaft of a Knob into the slot the Mount Bracket and push the Clamp toward the Knob. Thread the Knob into the Clamp and tighten. Repeat this for each Mount Bracket.

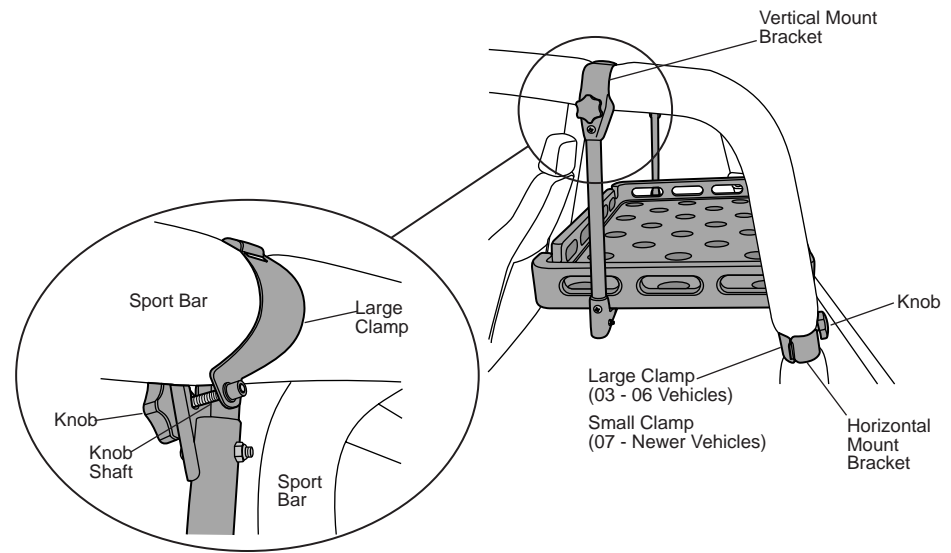

### 7 Tighten Fasteners

Fully tighten the screws that attach the Pivot Brackets and Vertical Mount Brackets to the Horizontal Bar. Make sure that the Knobs and fasteners are tight before using the Tray.



**CAUTION**

Do not load the tray with more than 75 evenly distributed Pounds.

## Lower Cargo Rack Bracket Installation Instructions

---

### LIMITED WARRANTY

We warrant our product to be free from defects in material and workmanship, for the terms specified below, provided there has been normal use and proper maintenance. This warranty applies to the original purchaser only. All remedies under this warranty are limited to the repair or replacement of any item or items found by the factory to be defective within the time period specified. If you have a warranty claim, first you must call our factory at the number below for instructions. You must retain proof of purchase and submit a copy with any items returned for warranty work. Upon completion of warranty work, if any, we will return the repaired or replaced item or items to you freight prepaid. Damage to our products caused by accidents, fire, vandalism, negligence, misinstallation, misuse, Acts of God, or by defective parts not manufactured by us, is not covered under this warranty.

THE WARRANTY TIME PERIOD IS AS FOLLOWS FOR REPLACE-A-TOP™, SAILCLOTH REPLACE-A-TOP™, SUPERTOP®, SUPERTOP® REPLACEMENT SKINS, SUNRIDER®, AND TIGERTOP®: TWO YEARS FROM DATE OF PURCHASE.

THE WARRANTY TIME PERIOD IS AS FOLLOWS FOR ALL OTHER "SOFT GOODS" MANUFACTURED BY OUR COMPANY (USING PRIMARILY VINYL, PLASTICS, AND/OR FOAM): ONE YEAR FROM DATE OF PURCHASE.

THE WARRANTY TIME PERIOD IS AS FOLLOWS FOR ALL OTHER "HARD GOODS" MANUFACTURED BY OUR COMPANY (USING PRIMARILY METALS, PLASTICS, AND/OR FIBERGLASS): ONE YEAR FROM DATE OF PURCHASE.

ANY IMPLIED WARRANTIES OF MERCHANTABILITY AND/OR FITNESS FOR A PARTICULAR PURPOSE CREATED HEREBY ARE LIMITED IN DURATION TO THE SAME DURATION AND SCOPE AS THE EXPRESS WRITTEN WARRANTY. OUR COMPANY SHALL NOT BE LIABLE FOR ANY INCIDENTAL OR CONSEQUENTIAL DAMAGE.

Some states do not allow limitations on how long an implied warranty lasts, or the exclusion or limitation of incidental or consequential damages, so the above limitations or exclusions may not apply to you. This warranty gives you specific legal rights, and you may also have other rights which vary from state to state.



For further information or request for warranty work, please contact:

Bestop Inc., Customer Service

Toll-Free: (800)845-3567

Main: (303)465-1755

E-mail: [csbestop@Bestop.com](mailto:csbestop@Bestop.com)

Website: [www.Bestop.com](http://www.Bestop.com)