

TOOLS NEEDED

- 5/8 wrench
- 16 mm socket
- 18 mm socket
- Extension
- Phillips screw driver
- Torque wrench
- Floor jack x 1
- 2 x 4 block of wood 12" x 1
- 4 x 4 block of wood 8" x 1

Torque Specification

- Isolator nuts 40 ft lbs.
- Mounting bolts 80 ft lbs.

BILL OF MATERIALS

M03763 x 12 body lift
S11082 x 24 stud extenders
P11153 x 1 thread lock



2007 Jeep Wrangler JK Body Lift 2dr & 4dr KJ04520BK



www.Daystaproducts.com

Tech Support Contact Info

Tech@DaystarWeb.com

Phone: 623.907.0081

Fax: 623.907.0088

841 South 71st Avenue

Instruction Sheet P11260-00

2007 Daystar Products International Inc.



Thank you for choosing Daystar Products

Daystar recommends a certified technician install this system. In addition to these instructions, professional knowledge of disassembly/reassembly procedures as well as post installation checks must be known. Attempts to install this system without this knowledge and expertise may jeopardize the integrity and/or operating of the vehicle.

Please read all the instructions before beginning the installation. Check the kit hardware against the parts list. Be sure you have all the needed parts and understand where they go. If anything is missing, do not proceed with the installation, Call Daystar Products to obtain needed items.

Product Use Information

As a general rule, the taller a vehicle is the easier it will roll. We strongly recommend, because of rollover possibility, that seat belts and shoulder harness be worn at all times. Avoid situations where a side rollover may occur.

Braking performance and capabilities are decreased when significantly large/heavier tires and wheels are used. Take this into consideration while driving. Also, speedometer recalibration is necessary when larger tires are installed.

Do not add, alter, or fabricate any factory or after-market parts which increase vehicle height over the intended height of the Daystar Product purchased. Mixing component brands, lifts, and/or combining body lift with suspension lift voids all warranties. Daystar makes no claims regarding lifting devices and excludes any and all implied claims. We will not be responsible for any products that is altered.

Notice to Dealer and Vehicle Owner

Any vehicle equipped with any Daystar Product must have the "Warning to driver" decal installed on the sun visor or dash. The decal is to act a constant reminder for whoever is operating the vehicle of its unique handling characteristics. **INSTALLING DEALER**— It is your responsibility to install the warning decal and forward these instructions on to the vehicle owner for review and to be kept in the vehicle for service life.

12. With all the body mount spacers installed remove the floor jack. use a 16mm socket and tighten all the 2 nuts per mount down to 40 ft lbs. Using a 18mm socket tighten down the 1 bolt per mount down to 80ft lbs.



13. Connect the electrical connectors(4) and position the grill(2) onto the front end of the grill support and seat the clips(3) fully. Install the push pin fasteners(1).

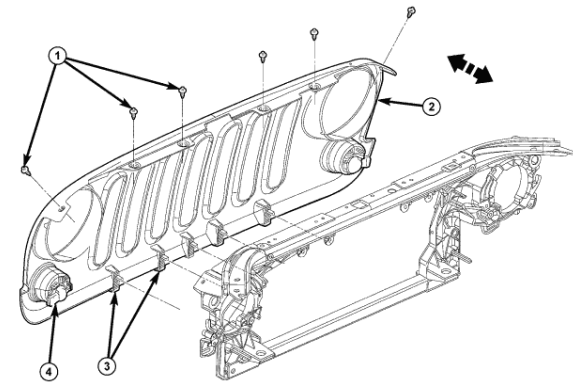

14. Close the hood down.
15. Check that all the bolts and nuts are tighten down to spec.
16. If a 2 door Jeep there will have lift over body mounts and stud extenders.
17. Check all bolt and nuts after 500 miles.

Other Daystar products for your Jeep.

- KJ09137 1 3/4 lift
- KJ09138 3/4 lift
- KU70032 Ft upper control arms
- KU70033 Rear upper control arms
- KU70034 Lower ft control arms
- KU70035 upper control arms
- KU70036 lower rear control arms, ft and rear
- KU70037 lower control arms rear.
- KU70038 complete arm kit

Installation steps

6. Slowly raise up the jeep with the block of wood between the jack and the tub of the jeep, about 4" off the body mounts and place 4x6 piece of wood between the frame and the jeep tub. Remove one mount at a time.



7. Place thread lock on the stud extenders.(2 at a time) Using a 5/8 wrench install the extenders on the body mount and tighten down.

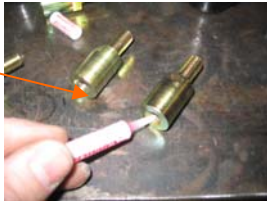

8. With the extenders tight install the body mount spacer over the stock mount.



9. With the spacer mount installed. Install the mount into the frame support.
(Note) When installing the front grill mount put the 2 studs in grill frame first, using the 2 studs and nut to hold the mount in the grill.



10. Repeat steps 7 to 9 with the remainder of the mounts on this side.
11. After you have installed on one side remove the 4x6 block of wood and lower down the Jeep tub onto the body mounts and install the 2 nuts and 1 bolt per mount and had tighten down and move the floor jack over to the other side and repeat steps 5 threw 10. If all the mounts have been installed, remove the 4x6 block of wood and lower jeep tub onto the body mounts.

1. The tools needed for installation are on the back cover. A list of parts in the kit are under the tool listing. Make sure have all of the proper tools and understand these directions before proceeding. Torque specs are on back cover.
2. If working on a 2dr module jeep, you will have 2 extra mounts and 4 extra stud extenders.
3. Place Jeep on a level ground. Open the hood and use a Phillips screw driver to twist the center of the push pin insert to release and remove the six push pin fasteners(1), release the lower clips(3) and separate the grille from the Jeep and disconnect the electrical connectors (4).

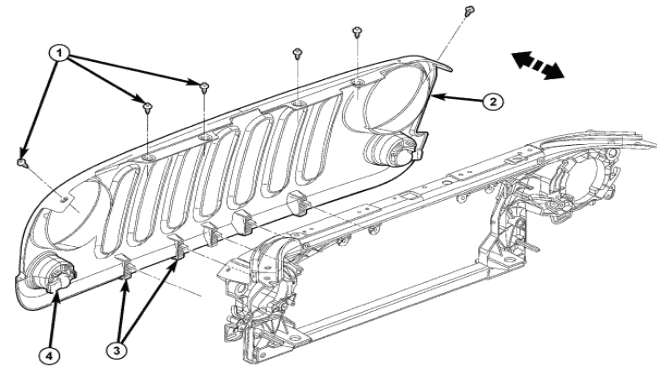

4. With a 16mm socket loosen the two nuts at each of the body mounts, with a 18mm socket loosen the one bolt at each of the body mount. DO NOT remove at this time. 2dr 10 mount / 4 door 12 mount locations.



5. Place the floor jack under the Jeep tub between the front and rear wheel. Rise up the jack with the 2x4 block of wood on top of the jack and remove only one side of the bolt and nuts from the Jeep.

