



INSTALLATION INSTRUCTIONS

APPLICATION: 2002-UP JEEP LIBERTY SPORT, LIMITED

AUTOMOTIVE PRODUCTS, INC.

<p>STEP BAR ASSEMBLIES</p> <p>25-2150 25-2155</p>	<p>PASSENGER SIDE</p> <p>DRIVER SIDE</p>
---	--

QTY	PARTS KIT CONTENTS DESCRIPTION	TOOLS REQUIRED
1	STEP BAR ASSEMBLY, PASSENGER SIDE	<p>3/4" SOCKET 19MM COMBINATION WRENCH 7/32" HEX WRENCH (ALLEN) RATCHET TORQUE WRENCH</p> <p>NOTE: FASTENERS ARE CONTAINED IN BOLT KIT 60-1221.</p>
1	STEP BAR ASSEMBLY, DRIVER SIDE	
1	FRONT MOUNT BRACKET, PASSENGER	
1	FRONT MOUNT BRACKET, DRIVER	
1	REAR MOUNT BRACKET, PASSENGER	
1	REAR MOUNT BRACKET, DRIVER	
6	BOLT PLATE	
6	PLASTIC WASHER	
8	3/8-16 X 1.00" BUTTON HEAD CAP SCREW	
8	3/8" INTERNAL TOOTH LOCK WASHER	
8	1/2" FLAT WASHER	
8	1/2" SPLIT LOCK WASHER	
6	1/2-13 HEX NUT	
2	5/8" FLAT WASHER	
2	M12-1.75 HEX NUT	

- STEP 1. Remove the contents from the box and check for any damage. Verify all parts against the parts list.
- STEP 2. Read and understand instructions completely before beginning installation.
- STEP 3. Determine driver front and rear mount brackets. Locate mount holes on frame for front and rear brackets. For rear mount location, insert (1) bolt plate through large hole on bottom of frame in to small hole on side of frame and use (1) plastic washer to hold in place. For front mount location, insert (2) bolt plates through large hole so that they protrude through smaller holes adjacent and use (2) plastic washer to hold in place. **See Figure 1.**
- STEP 4. Position driver rear bracket in place with (1) 5/8" flat washer above bracket as a spacer. Fasten to 12mm stud and 1/2" bolt plate using (1) 1/2-13 hex nut, (1) M12-1.75 hex nut, (2) 1/2" flat washer and (2) 1/2" lock washer. Leave fasteners loose.
- STEP 5. Position driver rear bracket in place and fasten to the bolt plates using (2) 1/2" flat washer, (2) 1/2" lock washer and (2) 1/2-13 hex nut. Leave loose.
- STEP 6. Place driver tube on cradles with bent leg forward and fasten together using (4) 3/8-16 x 1.00" button head cap screws and (4) 3/8" internal tooth lock washers. Leave loose.

STEP 7. Align and level tube with vehicle body. Torque 1/2" fasteners to 65 FT. LBS, 12MM fasteners to 60 FT. LBS and 3/8" fasteners to 25 FT. LBS.

STEP 8. Repeat step 3 through 7 for opposite side. **See Figure 2.**

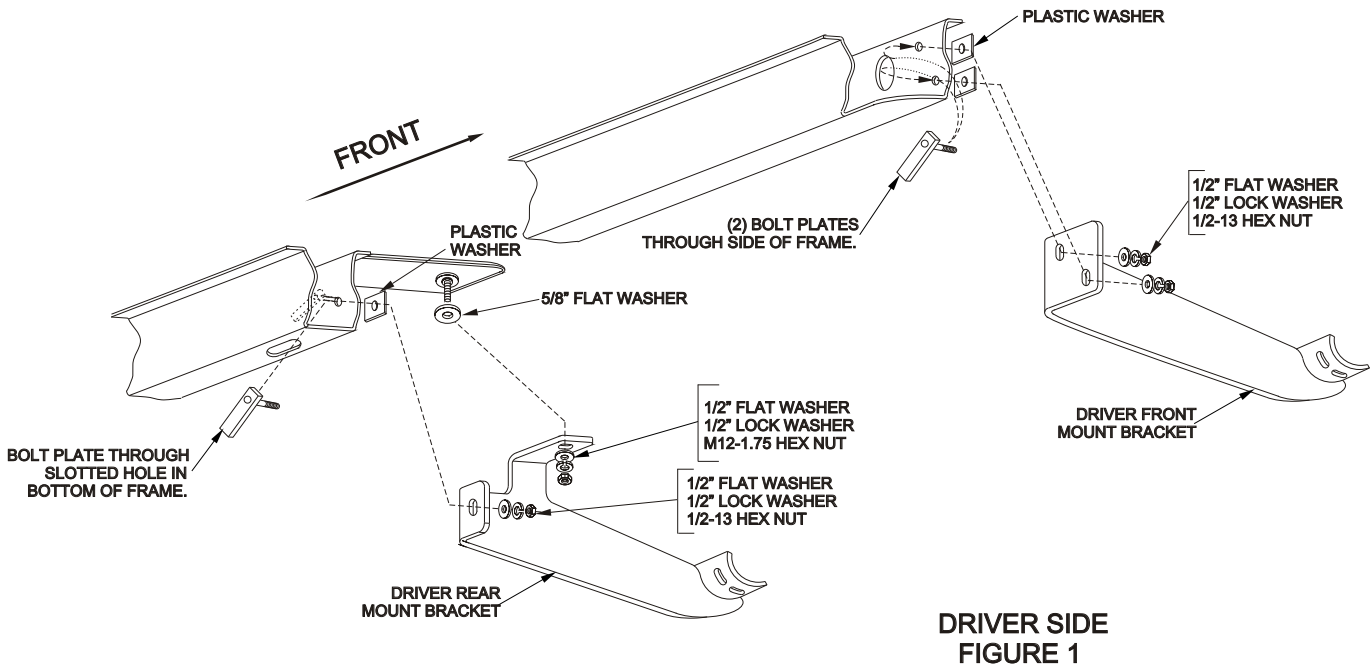
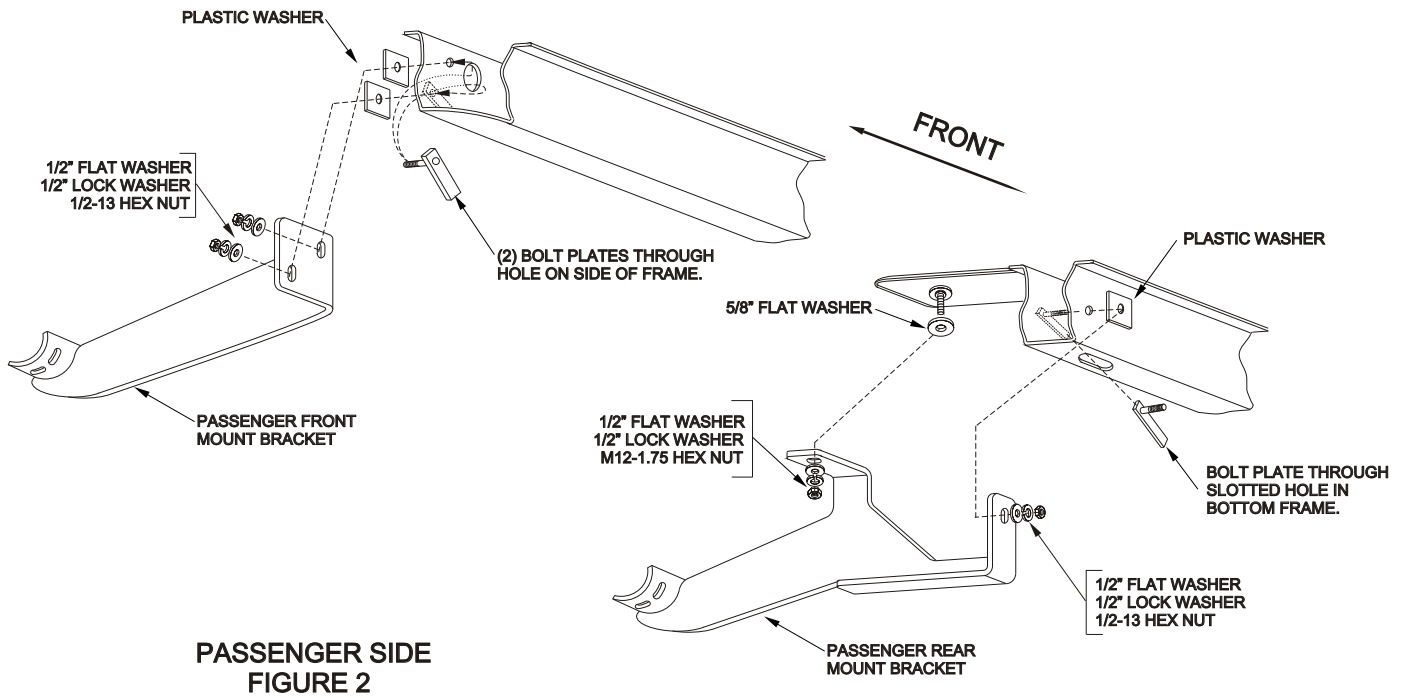

Finish protection - Westin products have a high quality finish that must be cared for like any other exposed finish on the vehicle. Protect the finish with a non-abrasive automotive wax (pure carnauba, for example) on a regular basis. The use of cleaner wax or any compound which contains an abrasive is detrimental, as the compounds scratch the finish and open it to corrosion.



Westin Automotive Products, Inc.
5200 N. Irwindale Ave. Suite 220
Irwindale, Ca. 91706

Thank You for choosing Westin products
For additional installation assistance please call
Customer service (800) 793-7846 or (507) 375-3559