

# **PAINLESS**

## **Wire Harness Installation Instructions Manual #90560**

**For Installing:**

**Part #10111  
1987 – 1991 Jeep YJ**





# **Perfect Performance Products, LLC**

**Painless Performance Products Division**

**2501 Ludelle Street**

**Fort Worth, TX 76105-1036**

**800-423-9696 phone – 817-244-4024 fax**

**Web Site: [www.painlessperformance.com](http://www.painlessperformance.com)**

**E-Mail: [painless@painlessperformance.com](mailto:painless@painlessperformance.com)**

If you have any questions concerning the installation of this harness or having trouble in general, feel free to call Painless Performance Products' tech line at 1-800-423-9696. Calls are answered from 8am to 5pm central time, Monday thru Friday, except holidays.

We have attempted to provide you with as accurate instructions as possible, and are always concerned about corrections or improvements that can be made. If you have found any errors or omissions, or if you simply have comments or suggestions concerning these instructions, please write us at the address on the cover and let us know about them. Or, better yet, send us a fax at (817) 244-4024 or e-mail us at [painless@painlessperformance.com](mailto:painless@painlessperformance.com). We sincerely appreciate your business.

**Perfect Performance Products, LLC** shall in no event be liable in contract or tort (including negligence) for special, indirect, incidental, or consequential damages, such as but not limited to, loss of property damage, or any other damages, costs or expenses which might be claimed as the result of the use or failure of the goods sold hereby, except only the cost of repair or replacement.

P/N 90560 Painless Wiring Manual

**January, 2008**

**Copyright © 2008 by Perfect Performance Products, LLC**

**CAUTION: BEFORE THE REMOVAL OF YOUR ORIGINAL HARNESS AND/OR THE INSTALL OF YOUR NEW PAINLESS HARNESS, DISCONNECT THE POWER FROM YOUR VEHICLE BY REMOVING THE NEGATIVE (BLACK) BATTERY CABLE FROM THE BATTERY.**

**NOTE :**

- A color copy of these instructions can be found at <http://www.painlessperformance.com/InfoSearch/manuals.php>
- If your vehicle has an existing harness, you will want to retain it for the possible re-use of various pigtails & connector housings particular to your application. During the removal process, avoid making any unnecessary cuts and label all connectors as they are disconnected. Labeling will allow quicker and easier identification in the event you need the OEM harness for reference during the install of your new Painless harness. It's a good idea to document how the original harness is routed as this Painless harness follows most of the same routing. If you plan on trying to re-use the factory fuel injection, be sure to retain all factory fuel injection wiring when removing the old harness. Circuits for the factory fuel injection are NOT included in this harness.
- If you do not have an existing harness, the package of terminals included with the harness that will enable you to make all of the connections needed. Replacement lighting pigtails & sockets can be readily obtained from your local parts distributor.
- Painless Performance Products recommends you, the installer, read this installation manual from front to back before installing this harness. Due to the variables in modifications that can be done to these Jeeps, reading this manual will give you considerable insight on the proper installation of this harness.
- Only printed wires will have a 900-series number. These 900-series numbers are used to identify various wires in the wiring diagrams that are a part of these instructions. The majority of those without a number come pre terminated with a connector installed.

# TABLE OF CONTENTS

## SECTIONS

1.0	INTRODUCTION .....	6
2.0	ABOUT THESE INSTRUCTIONS .....	6
3.0	CONTENTS OF THE PAINLESS WIRE HARNESS KIT .....	7
4.0	TOOLS NEEDED .....	7
5.0	PRE-INSTALLATION AND HARNESS ROUTING GUIDELINES.....	8
6.0	HARNESS INSTALLATION INSTRUCTIONS .....	8
6.1	Fuse Block and Bulkhead Installation .....	8
6.2	Harness Routing/Attachment.....	10
6.3	Grounding the Automobile.....	10
6.4	Terminal Installation and Making Connections.....	12
7.0	INTERIOR CIRCUIT CONNECTIONS.....	12
7.1	Headlight and Panel Dimmer Switch .....	12
7.2	Wiper Motor .....	14
7.3	Tachometer and Speedometer .....	14
7.4	Steering Column .....	14
7.5	Indicator Lights .....	16
7.6	Gauge Cluster .....	18
7.7	HVAC Section .....	18
7.8	Interior Ground .....	20
7.9	Optional and Accessory Equipment .....	20
8.0	TAIL SECTION .....	23
8.1	Tail Lights .....	23
8.2	Fuel Tank .....	23
8.3	Ground .....	23
8.4	Plate light .....	24
8.5	3 <sup>rd</sup> Brake Light .....	24
8.6	Rear Wiper Motor .....	24
9.0	FRONT HARNESS .....	25
10.0	HEADLIGHT SECTION .....	25
10.1	Brake Warning .....	25
10.2	Fuel Injection Wire .....	25
10.3	Washer Pump .....	26
10.4	Rear Washer Pump .....	26
10.5	Horn .....	26
10.6	Marker Lights .....	27
10.7	Turn/Park Lights .....	27
10.8	Headlights .....	27
10.9	Front Ground .....	27
11.0	ENGINE SECTION .....	28
11.1	Back Up & Neutral Safety Switch .....	28
11.2	Coil .....	28
11.3	Electric Choke .....	28
11.4	Heater Motor .....	28
11.5	Alternator Wiring .....	29
11.6	Maxi Fuse .....	30
11.7	Starter Solenoid .....	31
11.8	Sender Wires, Cooling Fan Relay, & A/C Compressor .....	31
12.0	TESTING THE SYSTEM .....	32
13.0	WIRE INDEX.....	28

## FIGURES

Figure 3-1 Painless Wire Harness Kit .....	7
Figure 6.1.1 Fuse Block Mounting Holes .....	9
Figure 6.1.2 Fuse Block Mounted .....	9
Figure 6.1.3 Bulkhead Mounted .....	9
Figure 6.2.1 Routing from the Fuse Block .....	11
Figure 6.2.3 Cut Grommet for TAIL SECTION .....	11
Figure 6.2.4 Headlight Section Through Support .....	11
Figure 7.1.2 Headlight Switch Terminal Removal .....	13
Figure 7.1.3 Headlight Switch Pin Out .....	13
Figure 7.1.6 Ill. Dimmer Switch Pin Out .....	13
Figure 7.3.1 Factory Tach. Pigtail .....	14
Figure 7.3.2 Speedo. Lighting Pigtail .....	14
Figure 7.4.1 Dimmer Switch .....	15
Figure 7.4.2 Wiper Switch Connection .....	15
Figure 7.4.3 Turn Signal Switch Connection .....	15
Figure 7.4.4 Ignition Switch & Brake Switch Connections .....	15
Figure 7.5.3 Ind. Light Connectors .....	17
Figure 7.5.4 Left Column Connector .....	17
Figure 7.5.5 Right Column Connector .....	17
Figure 7.6.3 Gauge Cluster (Back) .....	18
Figure 7.7.1 HVAC Switch .....	18
Figure 7.7.2 HVAC Panel Light .....	19
Figure 7.7.4 Heater Resistor .....	19
Figure 7.7.3 A/C Wires and Cigarette Lighter Wires.....	19
Figure 8.1.5 4 way Tail Lamp Connector .....	23
Figure 9.0 Front Harness .....	25
Figure 9.1.3 Brake Warn Switch .....	26
Figure 9.2.2 Washer Pump .....	26
Figure 10.4.2 Horn .....	26
Figure 10.6.1 Turn/Park Light with Grease .....	26
Figure 10.7.1 Headlight Connection .....	27
Figure 11.4.2 Heater Motor Tab .....	29
Figure 11.8.4 A/C Pressure Switch .....	31

## DIAGRAMS

Diagram 1 Indicator Light Circuit Board Connectors .....	16
Diagram 2 Fan Switch Wiring .....	22
Diagram 3 Fan Switch Wiring Used as a 12v Source .....	22
Diagram 4 Rear Wiper Connections .....	24
Diagram 5 Alternator B+ Wiring .....	29
Diagram 6 GM 2 Wire Alt. Connector .....	30
Diagram 7 GM 2 Wire Alt. Conn. with Diode.....	30
Diagram 8 Maxi Fuse.....	30
Diagram 9 GM 2 Wire Alternator .....	44
Diagram 10 Delco Alternator .....	44
Diagram 11 Mopar Alternator .....	45
Diagram 12 Motorcraft Alternator .....	45
Diagram 13 Delco Start/Run System .....	46
Diagram 14 Mopar Start/Run System .....	46
Diagram 15 Ford Start/Run System .....	47
Diagram 16 Duraspark Ignition System .....	47
Diagram 17 Mopar Electronic Ignition System .....	48

## 1.0 INTRODUCTION

You have purchased what we at Painless Performance Products believe to be the most up-to-date and easiest-to-install Jeep wire harness on the market. It is designed for easy installation, even if you have no electrical experience

All Kits have a built-in-anti-theft feature. Removing the fuse labeled “coil” from the fuse block will prevent the vehicle from starting.

The proper fuses have been pre-installed in the fuse block. In addition, all wires are color-coded and marked for easy identification. This will help you identify the different circuits during installation and later on if additions to the overall system are necessary. For wire color designations, see **Section 13.0**.

This Painless wire harness is designed to be used in the 1987-1991 Jeep YJ. All wire is 600 volt, 275°F, TXL. Standard automotive wire is GPT, 300 volt, 176°F, with PVC insulation.

This complete YJ wiring system has been designed with four major sections incorporated into it:

**ENGINE SECTION:** Water temperature, oil pressure, tachometer, coil, choke, a/c compressor clutch, ignition bypass, battery feed and alternator

**HEADLIGHT SECTION:** Includes high beam, low beam, park lights, marker lights right turn, left turn, horns, starter solenoid, washer pump, brake warning, reverse switch and neutral safety switch

**UNDER-DASH and INTERIOR SECTION:** Includes wires to connect heater-a/c switch, headlight switch, turn signal switch, radio, tachometer, ignition switch, cigar lighter, dimmer switch, brake switch, a/c blower motor, wiper switch, gauges and indicator lights, right and left door jam switches, shift indicator light, courtesy lights, dome light, clock.

**REAR LIGHT SECTION:** Includes, taillights, stoplights, left and right turn signals, backup lights, license plate light, and fuel sending unit.

## 2.0 ABOUT THESE INSTRUCTIONS

The contents of these instructions are divided into major **Sections**, as follows:

- 1.0 Introduction
- 2.0 About These Instructions
- 3.0 Contents of Painless Wire Harness Kit
- 4.0 Tools Needed
- 5.0 Pre-Installation and Harness Routing Guidelines
- 6.0 Harness Installation Instructions
- 7.0 Interior Circuit Connections
- 8.0 Tail Section Connections
- 9.0 Front harness
- 10.0 Headlight Section Connections
- 11.0 Engine Section Connections
- 12.0 Testing the System
- 13.0 Wire Connection Index

Sections are divided into subsections and **Paragraphs**. Throughout these instructions, the **Figure** numbers refer to pictures and the **Diagram** numbers refer to illustrations. **Figure** numbers correspond to the Section number they are covered in. Always pay special and careful attention to any *Notes* and any text marked **Caution**.

### 3.0 CONTENTS OF THE PAINLESS WIRE HARNESS KIT

Refer to the list below to take inventory of all the parts in the kit. If anything is found to be missing, contact the dealer the kit was purchased from or Painless Performance at (800)423-9696. The 1987-1991 Jeep YJ Wire Harness Kit should contain the following items:

- The Main Wire Harness, with bulkhead and Fuse Block, pre-wired fuses and relays installed.
- The engine compartment bulkhead, with headlight and engine sections pre-wired
- Bag Kit: 1 pkg. of small and 1 pkg. of large Nylon Tie Wraps, Maxi Fuse, 1 Grommet
- Parts Box containing Terminals, Splices, Spare Fuses etc.

**Figure 3-1** Painless Wire Harness Kit

### 4.0 TOOLS NEEDED

In addition to basic hand tools the following will also be needed:

- Crimping Tool *Note: Use a quality tool to avoid over-crimping.*
- Wire Stripper
- Test Light or Volt Meter
- Small (10 amp or less) Battery Charger
- Electric drill
- ¼ drill bit
- Dielectric compound/grease

## 5.0 PRE-INSTALLATION AND HARNESS ROUTING GUIDELINES

**Before routing or installation see 8.6.5, page 23, it will be easier to pull this wire before the harness is routed.**

Installation of this wire harness consists mainly of two parts:

- The physical routing and securing of the wire harness.
- The connection of the individual circuits to their components.

These two major tasks are not separate steps, but are integrated together. In other words, you will route a section of wires and make that sections connections. Route the next section of wires and make those sections connections. The layout of this harness will dictate how to physically route the harness in your Jeep. The breakouts and connections are very close to the original OEM harnesses and should fit just as well if not better. The fitment greatly depends on to what extent you want to secure and conceal the harness. Painless offers some general guidelines and routing practices starting in **Section 5.2**, GENERAL installation instructions in **Section 6.0**, and precise instructions concerning the electrical connections you will make in **Section 7.0**. To help you begin thinking through the installation of your wire harness please read the following sections:

- 5.1** Familiarize yourself with the harness by removing the harness from the box, laying it out on a table or on the floor and locating each of the harness sections. Whenever a particular harness section is referred to in these instructions it is shown in "all caps": ENGINE SECTION.
- 5.2** It is recommended to route the harness through and around open areas inside the Jeep. Inside edges provide protection from hazards and also provide places for tie wraps, clips, and other support.
- 5.3** Route the harness away from sharp edges, exhaust pipes, hood and door hinges.
- 5.4** Plan where harness supports will be located. Allow enough slack at places where movement could occur (body to frame, frame to engine, etc.)
- 5.5** At wire ends, don't depend on the terminals to support the harness. The weight of the harness could cause terminals to disconnect or copper wire strands to break.
- 5.6** The wires should be bundled into groups. Use nylon ties, poly split loom, tape, or PowerBraid (see Painless part #70920 for details)

## 6.0 HARNESS INSTALLATION INSTRUCTIONS

### 6.1 Fuse Block and Bulkhead Installation

- 6.1.1** Using a ¼" drill bit and an electric drill, enlarge the factory fuse block mounting holes on the firewall. (see **Figure 6.1.1**)
- 6.1.2** Using the hardware provided, mount the fuse block as shown in **Figure 6.1.2**. Mounting the fuse block as shown will ensure the text below the fuses is not upside down when viewed from the interior.
- 6.1.3** Connect the HEADLIGHT/ENGINE Section bulkhead to the fuse block. Tighten the bulkhead down with the screw located in the middle of the bulkhead connector. Some zip ties may need to be cut in order to get to the screw. see **Figure 6.1.3**

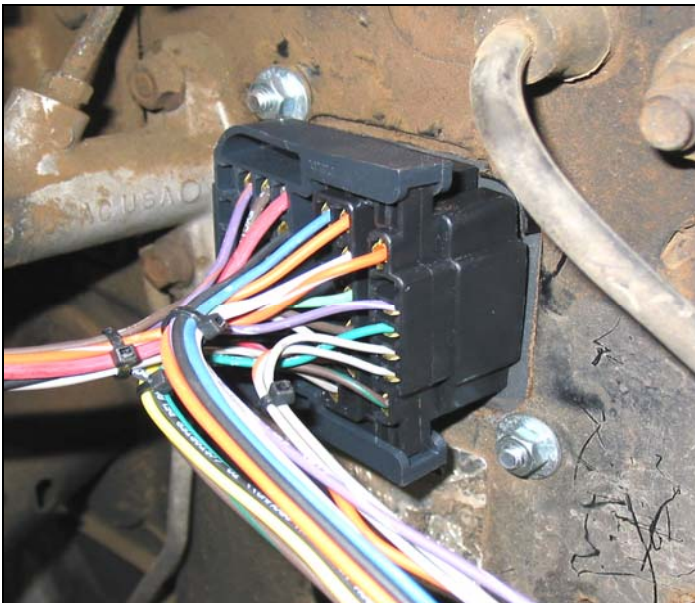




**Figure 6.1.1** *Fuse Block Mounting Holes*



**Figure 6.1.2** *Fuse Block Mounted*



**Figure 6.1.3** *Bulkhead Mounted*

## 6.2 Harness Routing/Attachment

\*Harness routing and shaping is and should be a time-consuming task. Taking your time will enhance the beauty of your installation. Please be patient and TAKE YOUR TIME! Remember to route the harness away from sharp edges, exhaust pipes, hood, trunk, and door hinges.

- 6.2.1 Route the INTERIOR and TAIL SECTION from the fuse block as shown in **Figure 6.2.1**. The TAIL SECTION needs to be routed to the left of the parking brake and the INTERIOR SECTION can be run across the brace for the steering column. Additional routing of the INTERIOR SECTION will be done as you make connections to the switches and components in the dash. Remember that dash wires should be routed out of the way of any under-dash obstacles, such as vent levers, air conditioning controls, radio, etc.
- 6.2.2 The TAIL SECTION will need to be routed just like the OEM harness ,down under the driver's side door, up the rear quarter panel, over the rear driver side wheel tub, and down through the hole to the tail lights.
- 6.2.3 Locate the large rubber grommet included in the parts kit. Cut one side of the grommet, as depicted in **Figure 6.2.3**. DO NOT CUT THE GROMMET IN HALF; only one side needs to be cut. With the grommet cut, it will now fit around the wires, and can be fit into the hole the tail section passed down though.
- 6.2.4 The HEADLIGHT SECTION will need to be routed just like the OEM harness, across the driver's side front fender, towards the core support. Pass the HEADLIGHT SECTION through the hole at the bottom of the core support. The wiring for the passenger's side will run across the bottom of the core support over to the right side of the vehicle. (see **Figure 6.2.4**, and **9.0**)
- 6.2.5 ENGINE SECTION routing is covered in **9.3**
- 6.2.6 When using wire loom on the visible areas of the harness, it will need to be wire tied every 12" or so. This will make a very attractive assembly. Under the dash a tie installed every 6" or so will hold the wires in place nicely. Remember to take your time.

***Note: Do not tighten tie wraps and mounting devices until each individual connection has been made on the particular circuit to be wire tied. Make all harness attachments LOOSELY, until all connections are made in each section.***

## 6.3 Grounding the Jeep

This Painless Wire Harness Kit includes the following ground wires: one front ground connection, one tail ground connection, one ground connection for the interior, and one built-in ground wire for the horn relay. Making these ground connections will be more thoroughly covered in the specific connection section. Any additional circuits or accessories requiring a ground will have to be added.

- 6.3.1 Connect a Ground Strap or Cable (even a 10-gauge wire is too small) from the Negative Battery terminal to the automobile frame.
- 6.3.2 Connect a Ground Strap from the Engine to the frame. **DO NOT RELY UPON THE MOTOR MOUNTS TO MAKE THIS CONNECTION.**
- 6.3.3 Connect a Ground Strap from the Engine to the Body.



**Figure 6.2.1** Routing from the Fuse Block



**Figure 6.2.3** Cut Grommet for TAIL SECTION



**Figure 6.2.4** Headlight Section Through Core Support

## 6.4 Terminal Installation and Making Connections

*Note: In the following steps you will be making the circuit connections. Before you start, you should carefully read **Sections 7.0-11.0**, as appropriate, and refer to **Section 13.0** as needed, **DOUBLE-CHECKING** your routing and length calculations before cutting any wires and making connections. The majority of the harness has been pre-terminated.*

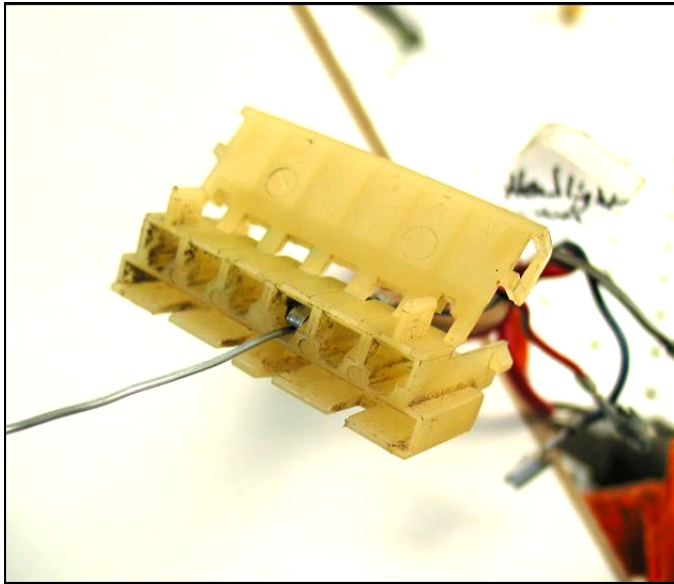
- 6.4.1 Have all needed tools and connectors handy.
- 6.4.2 Select the correct size terminal for the wire application.
- 6.4.3 Determine the correct wire length and cut the wire. Remember to allow enough slack in the harness and wires at places where movement could possibly occur, such as automobile body to frame, frame to engine, etc. **Double-check your calculations.**
- 6.4.4 Strip the insulation from the wire. Strip only enough necessary for the type of terminal you are using. All of the terminals included in this kit require a ¼" strip length.
- 6.4.5 Insert the stripped portion of the wire into the crimp side of the terminal. Be careful as to not allow the individual wire strands to fray during insertion.
- 6.4.6 Crimp the terminal onto the wire using the proper jaw location on the crimpers.  
*Note: In step 6.4.6 be sure to use the proper jaw location on your crimpers. Most crimping tools have it color coded for which cavity to use. 18-22ga – Red, 16-14ga – Blue, and 12-10ga – Yellow. **CAUTION: DO NOT OVER-CRIMP!***
- 6.4.7 Many connections will be made throughout the installation process. Make sure each wire is **FIRST** properly routed and **THEN** attach. **DO NOT ATTACH FIRST AND ROUTE AFTERWARD.**
- 6.4.8 After all wires are terminated and securely attached, tighten the mounts and/or zip ties to secure the harness permanently.

## 7.0 INTERIOR CIRCUIT CONNECTIONS

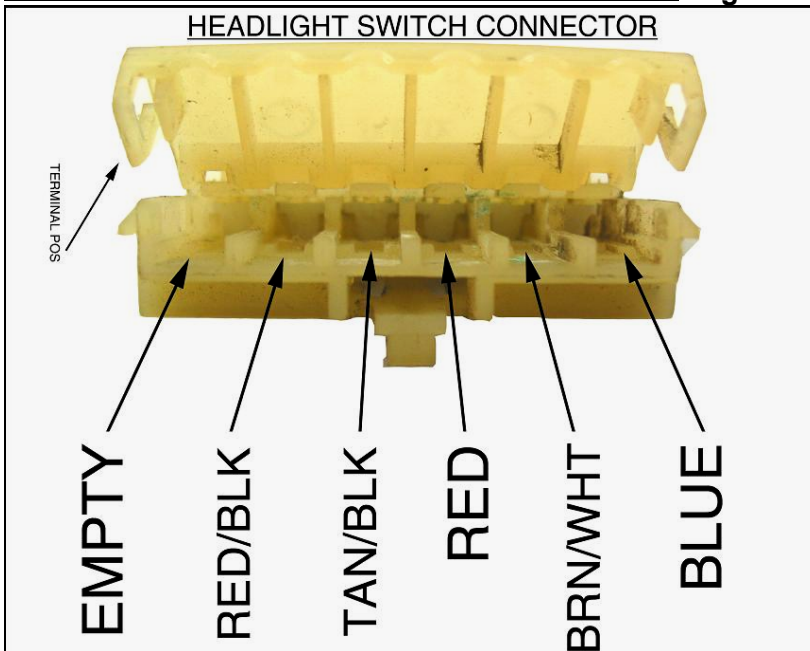
**Note: Power for the PANEL DIMMER SWITCH comes through the 5 AMP inline fuse coming from the HEADLIGHT SWITCH.**

### 7.1 Headlight and Panel Dimmer Switch-

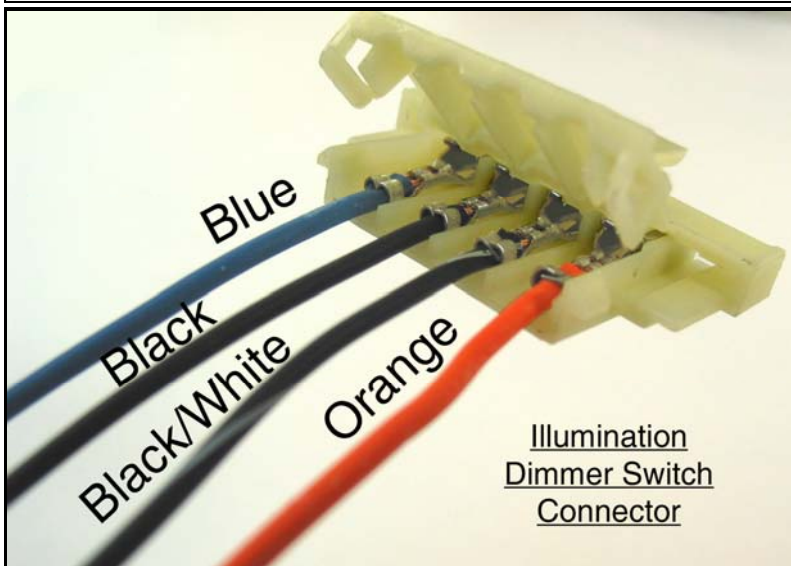
- 7.1.1 The painless harness comes with the HEADLIGHT SWITCH wires pre-terminated with non-insulated terminals. This is because the factory plastic connector is no longer available and you must re-use the connector from your factory harness. If you do not have a connector to re-use, skip to **7.1.4**.
- 7.1.2 Remove the factory terminals by using a terminal pick or stiff wire, such as a paperclip. Insert the wire or pick as shown in **Figure 7.1.2**. Doing so will depress the locking tang and the factory terminal and wire can be removed from the connector. Make sure the terminal position lock is undone or the terminal will not come out.
- 7.1.3 Using **Figure 7.1.3** for reference, insert the wires from the Painless kit into the correct position in the connector. The terminal will only go into the connector one way. If the terminal does not lock, do not force it; make sure you do not have it in upside down. Close the terminal position lock when finished.
- 7.1.4 If you do not have a factory connector, you can simply install the terminals over the "pegs" coming out of the switch, using **Figure 7.1.3** for reference. If you must make this connection in this manner, electrical tape or heat shrink should be placed around the terminals on the Painless harness before installation to ensure they do not short with one another if they ever happen to make contact.
- 7.1.5 With the headlight switch properly pinned out, slide the connector onto the HEAD LIGHT SWITCH to make your connection.
- 7.1.6 The PANEL DIMMER SWITCH wires come pre-terminated. The factory connector will need to be reused. The terminals remove just as the HEADLIGHT SWITCH terminals did. Use **Figure 7.1.2** and **Figure 7.1.6** to re-pin this connector.



**Figure 7.1.2** Headlight Switch Terminal Removal



**Figure 7.1.3** Headlight Switch Pin Out



**Figure 7.1.6 Ill. Dimmer Switch Pin Out**

## 7.2 Wiper Motor

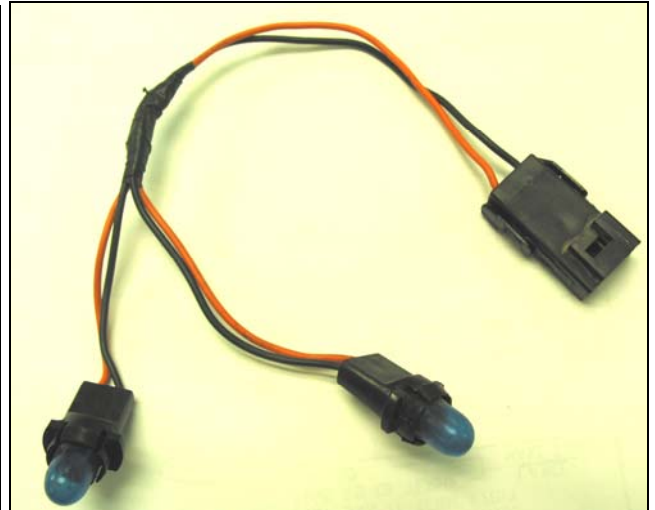
- 7.2.1 The WIPER MOTOR wires come pre-terminated with a connector installed. Connect this connector onto the WIPER MOTOR pigtail, located under the windshield, at the upper left driver's side of the dash.

## 7.3 Tachometer and Speedometer

- 7.3.1 The TACHOMETER wires come pre-terminated with a connector installed. Connect this connector onto the Tachometer pigtail coming from the gauge. **See Figure 7.3.1**
- 7.3.2 The SPEEDOMETER wires come pre-terminated with a connector installed. This connector provides power to the lighting of the speedometer. Connect this connector onto the factory Speedometer lighting pigtail coming from the gauge. **See Figure 7.3.2**



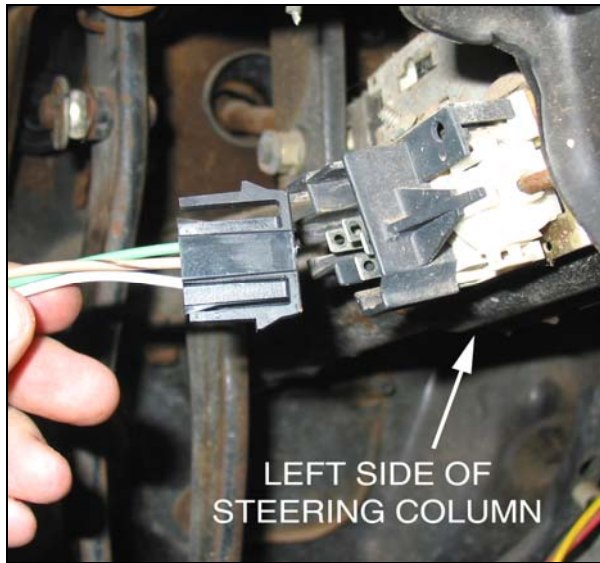
**Figure 7.3.1** *Factory Tach. Pigtail*



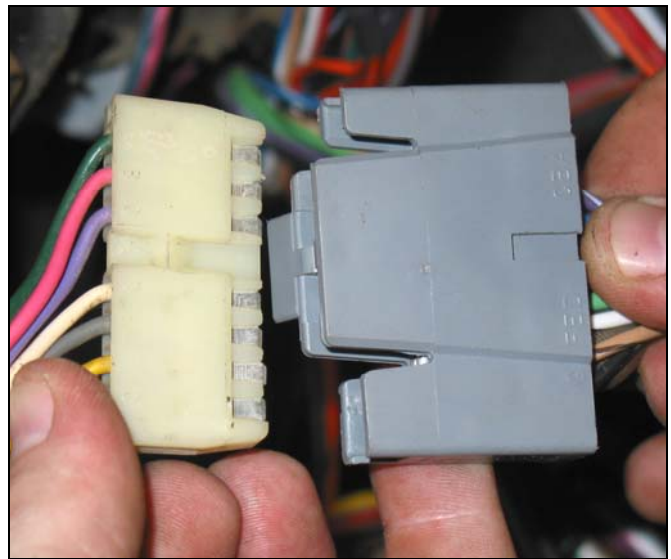
**Figure 7.3.2** *Speedo. Lighting Pigtail*

## 7.4 Steering Column

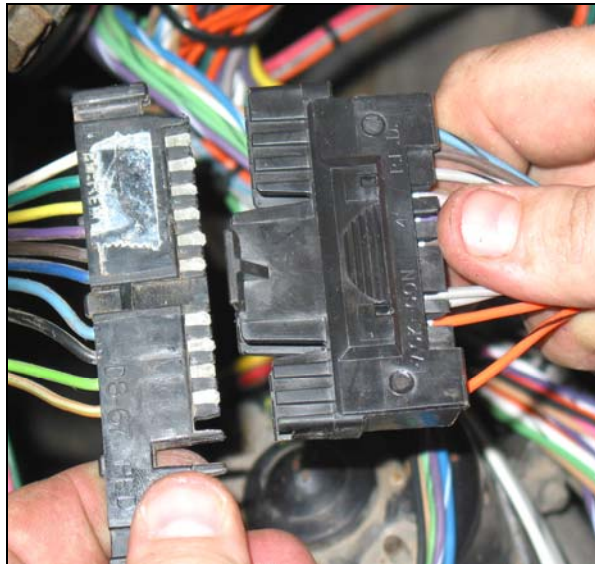
- 7.4.1 The DIMMER SWITCH wires come pre-terminated with a connector installed. Slide the connector onto the DIMMER SWITCH, located on the left side of the column, to make your connection. **See Figure 7.4.1**
- 7.4.2 The WIPER SWITCH wires come pre-terminated with a connector installed. Slide the connector onto the WIPER SWITCH pigtail. (see **Figure 7.4.2**) This will be the wires coming from the column with the white connector.
- 7.4.3 The TURN SWITCH wires come pre-terminated with a connector installed. Slide the connector onto the TURN SWITCH pigtail. (see **Figure 7.4.3**) This will be the wires coming from the column with the long black connector.
- 7.4.4 The IGNITION SWITCH consists of two connectors; both are installed on the new Painless harness. The black connector will need to be installed first. Locate the IGNITION SWITCH connecting point on the top of the steering column. The Black connector goes into position on the end closest to the firewall. The White connector installed on the other group of IGNITION SWITCH wires will need to go on the end closest to the steering wheel and must only be installed after the Black connector is in its place. Use **Figure 7.4.4** for reference.
- 7.4.5 The two BRAKE SWITCH wires come with a connector already installed. Locate the BRAKE SWITCH at the top of the brake pedal near the steering column. (see **Figure 7.4.4**) The BRAKE SWITCH is not polarity specific so it does not matter which way the connector is installed.



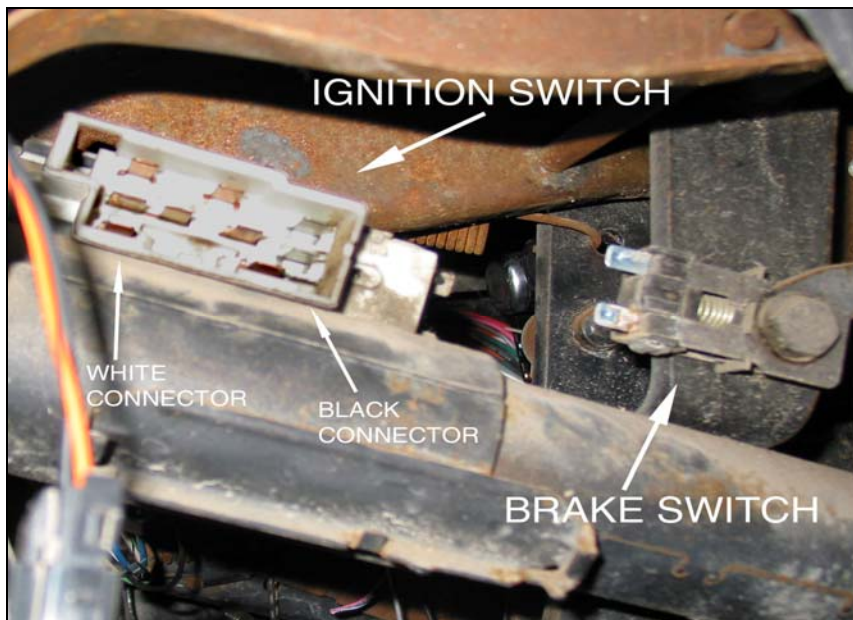
**Figure 7.4.1** Dimmer Switch



**Figure 7.4.2** Wiper Switch Connection



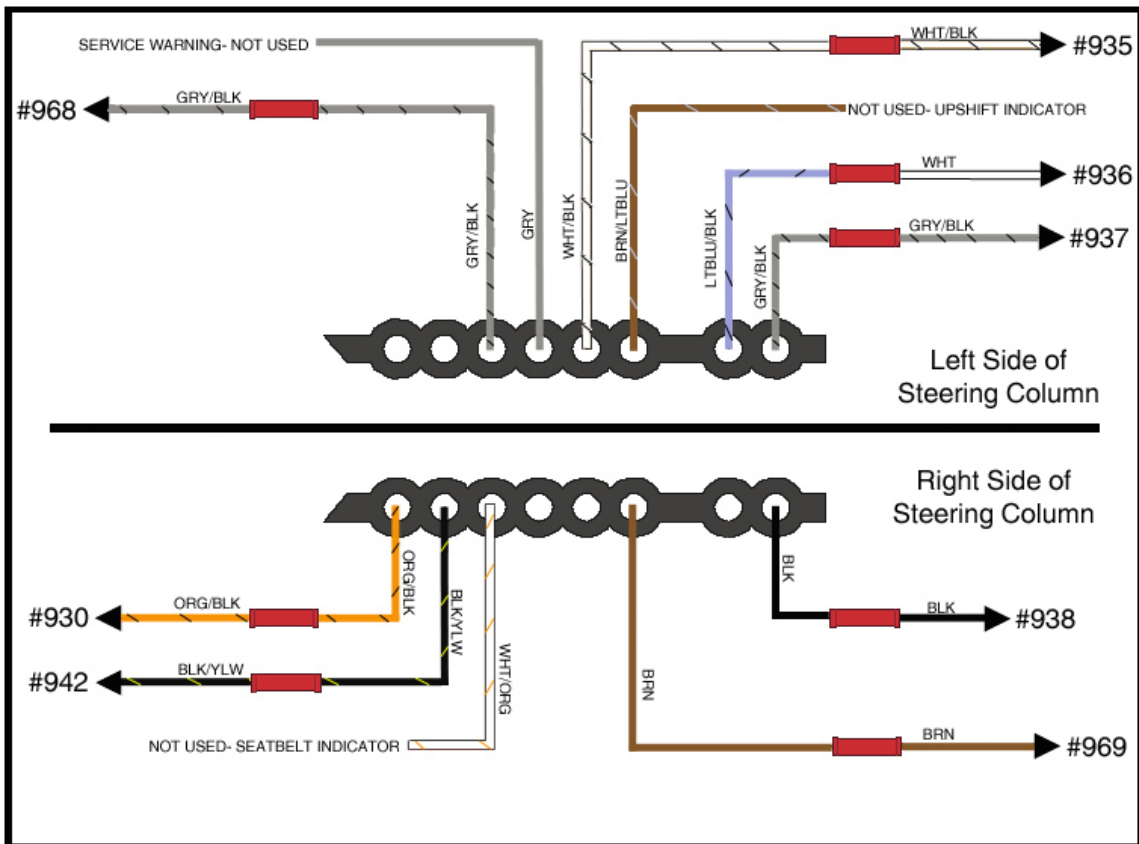
**Figure 7.4.3** Turn Signal Switch Connection



**Figure 7.4.4** Ignition Switch & Brake Switch Connections

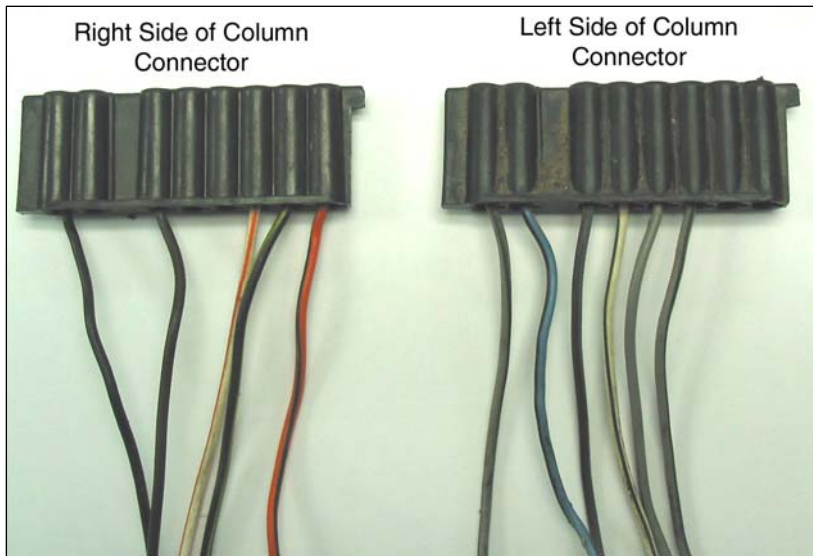
## 7.5 Indicator Lights

- 7.5.1** Your new Painless harness has the wires for the Indicator Lights split into 2 groups labeled “LEFT COLUMN CONN.” and “RIGHT COLUMN CONN.”
- 7.5.2** These two groups have splices pre-installed on them. This is due to the fact that the connector and terminal the factory used is no longer available. The original connectors must be re-used in order to make these connections.
- 7.5.3** Start by cutting the original connectors from your factory harness. Cut the factory wires to make two pigtails to splice to your new Painless harness, about 6”- 8” from the connector. (see **Figure 7.5.3**) This will give you plenty of length to splice to. This will also ensure you have enough length to route and connect to the Indicator light printed circuit board.
- 7.5.4** Begin by splicing the LEFT COLUMN CONN. wires to the connector that goes to the Indicator Light Circuit Board to the left of the steering column. The factory connector will contain the following wires: *gray/black, lt.blue/black, brown/lt.blue, white/black, gray, & gray/black.* Connect the Painless wires to the factory wires as shown in **Diagram 1.** Also see **Figure 7.5.4.**
- 7.5.5** Splice the RIGHT COLUMN CONN. wires to the connector that goes to the Indicator Light Circuit Board to the right of the steering column. The factory connector will contain the following wires: *black, brown, white/orange, black/ yellow, & orange/black.* Connect the Painless wires to the factory wires as shown in **Diagram 1.** Also see **Figure 7.5.5**
- 7.5.6** There will be a couple of wires in these connectors that the Painless harness does not support. These wires can be left alone and stowed in the harness, or removed, it is your decision.
- 7.5.7** When you have made the correct splices, connect to the appropriate side on the printed circuit. Before installation of these connectors, look over the printed circuit to ensure it is free of any dirt and dust and does not have any burnt ribbons.

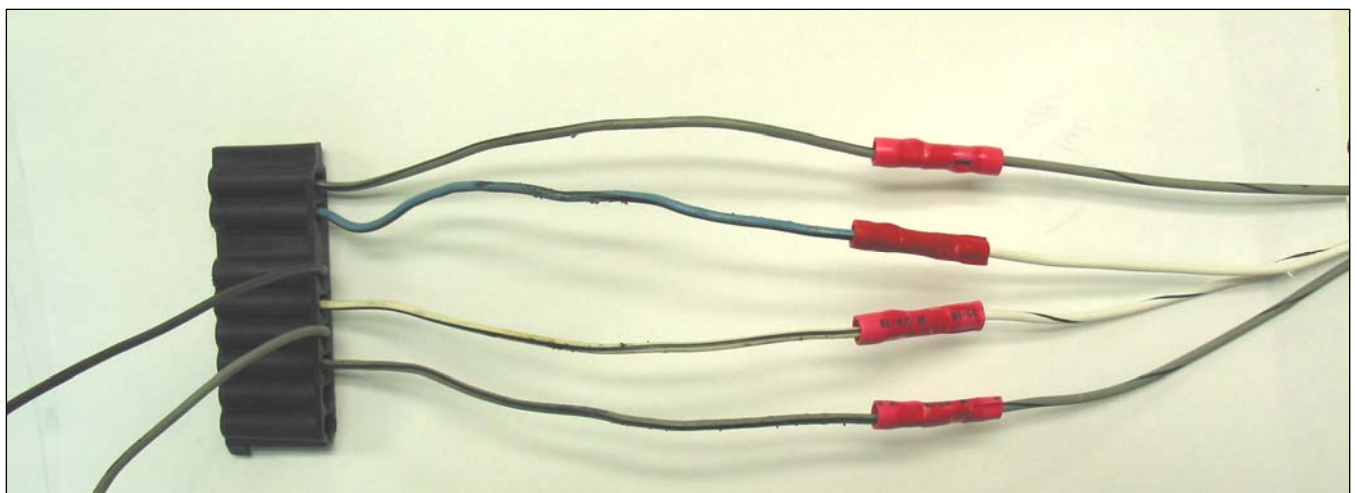


**Diagram 1** Indicator Light Circuit Board Connectors

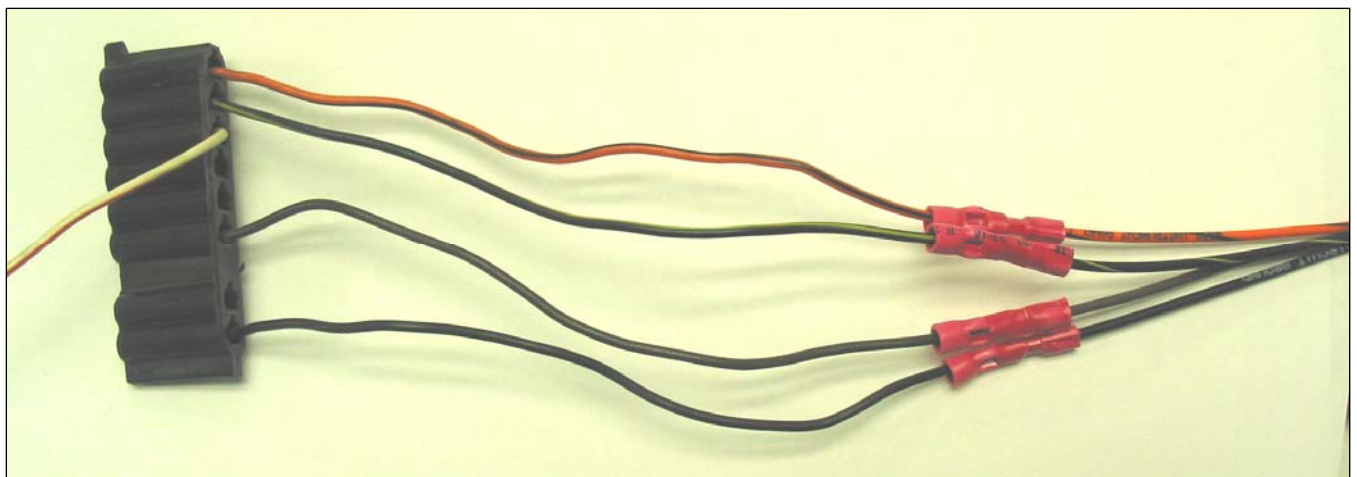




**Figure 7.5.3** *Ind. Light Connectors*



**Figure 7.5.4** *Left Column Connector*



**Figure 7.5.5** *Right Column Connector*

## 7.6 Gauge Cluster.

- 7.6.1 The GAUGE CLUSTER wiring comes with terminals pre-installed with a black 12 way connector installed.
- 7.6.2 Before installation of this connector, look over the printed circuit to ensure it is free of any dirt and dust and does not have any burnt ribbons.
- 7.6.3 Notice the connector has a bigger tab on one end, **Figure 7.6.3**. This will be the same end as the installed Pink wire and the Light Blue wire. Match this bigger end to the bigger end of the Gauge Cluster connector opening on the back of the gauge cluster.

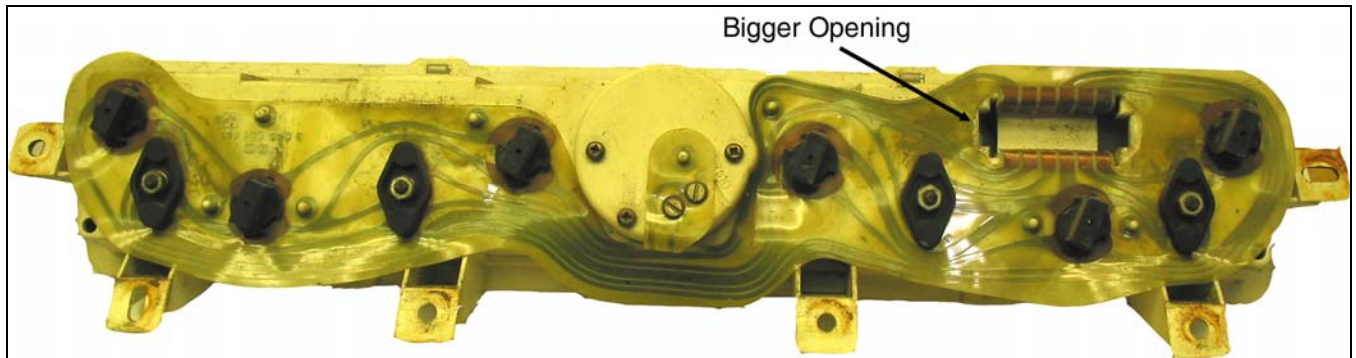


Figure 7.6.3 Gauge Cluster (Back)

## 7.7 HVAC Section

- 7.7.1 Connect the black 4 way connector to the heater switch. see **Figure 7.7.1**
- 7.7.2 Cut the HVAC light from the factory harness. Cut the wires 4" – 6" from the light socket. Insert this "pigtail" in to the hole on the right side of the HVAC switch, see **Figure 7.7.1**. Route the Orange/Black #930 HVAC PANEL LIGHT (B+) & the Black #969 HVAC PANEL LIGHT GROUND to the pigtail. Cut the #930 and #969 wires to length. Strip the two wires of the pigtail and the two wires from the Painless harness. Using the two of the splices provided in the parts kit, splice the #930 & #969 wires to the panel lamp, matching the Painless colors to the factory colors. see **Figure 7.7.2**
- 7.7.3 Connect the White #998 MICRO SWITCH (BACK) wire to the back of the heater micro switch. Connect the White #900 MICRO SWITCH (FRONT) wire to the front of the heater micro switch. see **Figure 7.7.1**

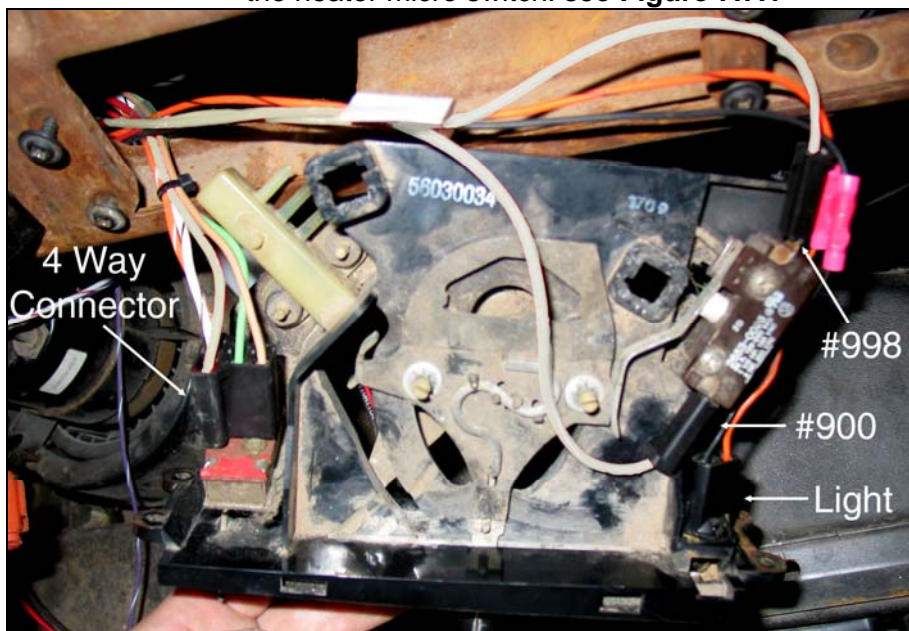
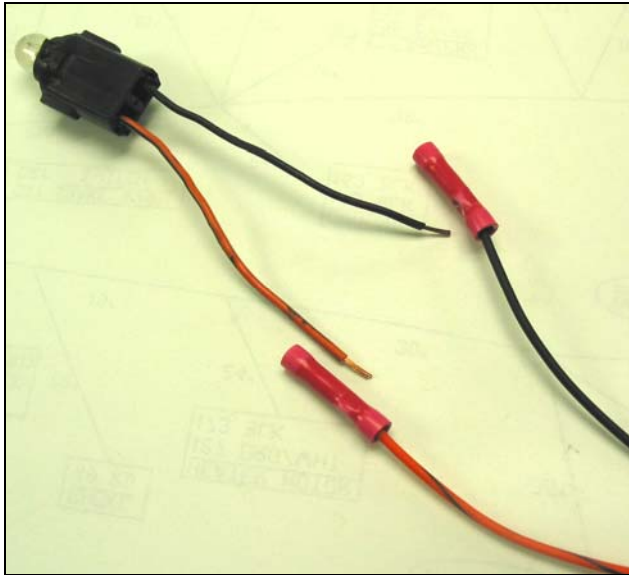
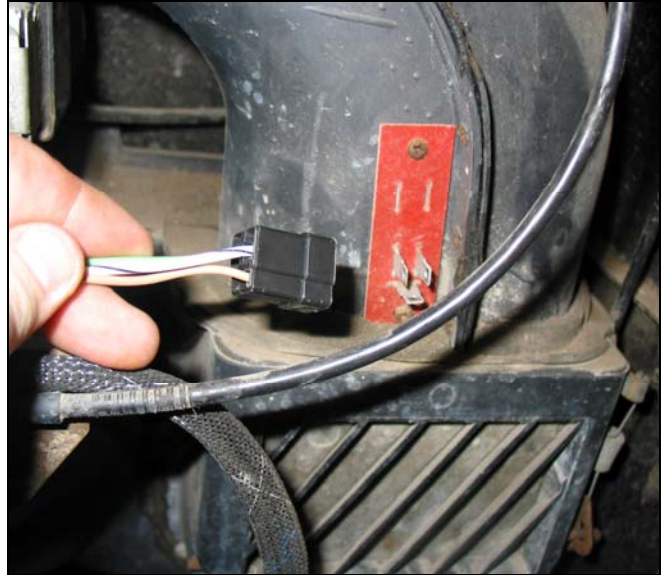


Figure 7.7.1 HVAC Switch

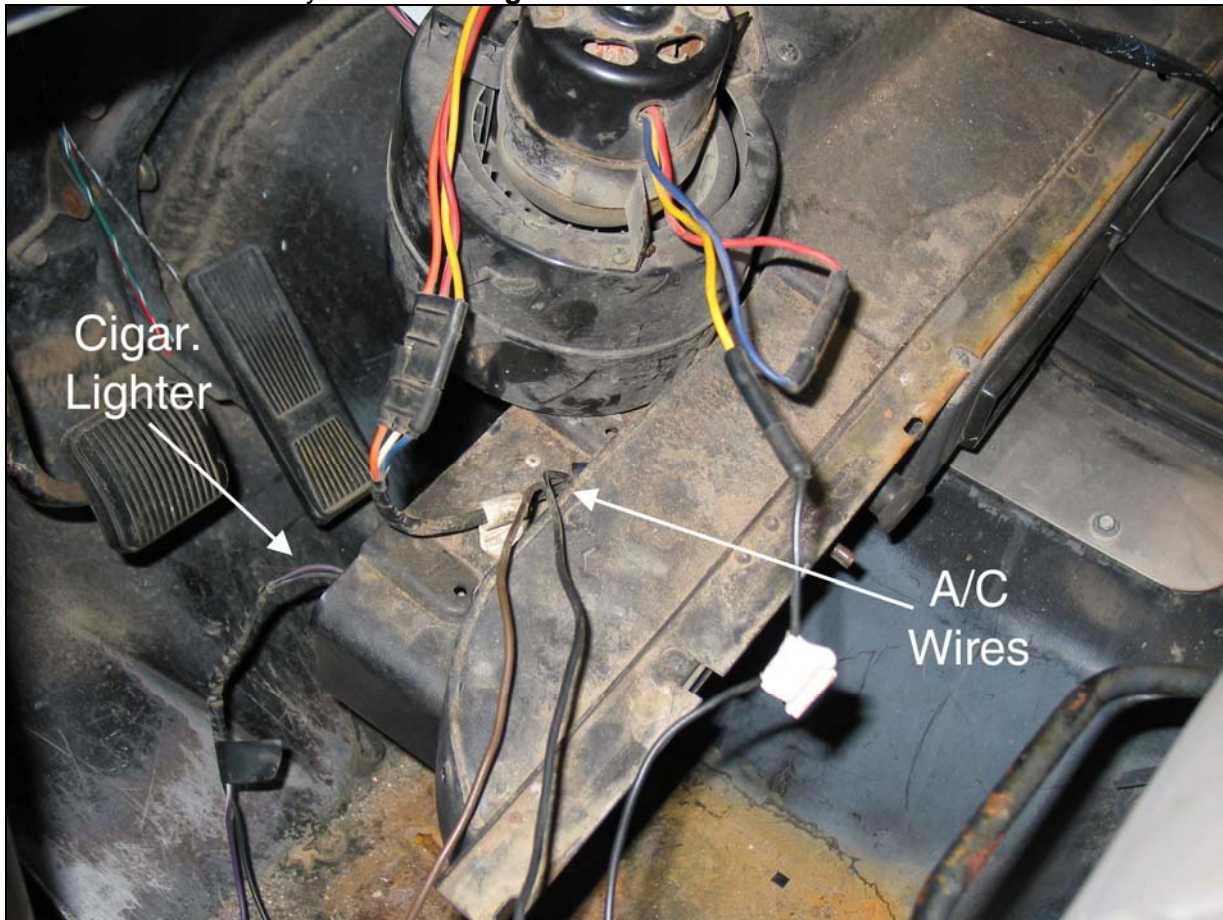


**Figure 7.7.2** HVAC Panel Light



**Figure 7.7.4** Heater Resistor

- 7.7.4** Locate the HEATER RESISTER connector pre-installed on the Painless harness. This will be a black 3-way "T" shaped connector. This connector needs to be connected to the 3 prongs located in the passenger side foot well, see **Figure 7.7.4**.
- 7.7.5** Locate the Brown and the Black wires coming from the A/C motor. Route the Brown and the Black wires of the Painless harness, labeled "A/C SWITCH", over to these 2 wires. The two Painless wires already have splices pre-installed. Cut the 2 factory wires to length, strip, and make your connections by matching the Painless colors to the factory colors. see **Figure 7.7.5**



**Figure 7.7.3** A/C Wires and Cigarette Lighter Wires

## 7.8 Interior Ground

- 7.8.1 All ground wires in the Interior portion of the harness all trace back to two wires.
- 7.8.2 These two wires are located near the fuse block, labeled "GROUND", and have a ring terminal pre-installed.
- 7.8.3 Connect this ring terminal to a good clean ground. There should be enough length in order for you to find an existing bolt or screw to attach the ground to.

## 7.9 Optional and Accessory Equipment

**NOTE: With the exception of the FUEL PUMP B+ wire, any wires labeled B+ that are not being used, should have the ends taped or heat shrink applied to ensure they do not short. These wires carry constant or switched power and should not be left unprotected.**

### Electric Fuel Pump

- 7.9.1 Located near the fuse block, there is a coil of Orange wire labeled # 947 "FUEL PUMP B+". This wire runs to the fuel tank connector located in the TAIL SECTION. This wire is there for the convenience of those using an electric in tank FUEL PUMP. Those running an in-line pump can simply remove this wire from the connector at the fuel tank. If an electric pump is being used, #947 needs to be connected to the *OUTPUT* side of a Fuel Pump Relay (*Painless Part # 50102 or # 30131*).

### Door Switches

- 7.9.2 Located in the Painless harness there are two wires to accommodate the use of DOOR SWITCHES to turn the dome light and courtesy lights on when a door is opened. A Black/White wire labeled # 987 LEFT DOOR JAMB SWITCH is located in the first breakout close to the fuse block. The second black/white wire, labeled #988 RIGHT DOOR JAMB SWITCH, is located in the same breakout as the HEATER RESISTOR, RADIO, RIGHT COURTESY LIGHT, and FAN SWITCH. Connections can be made to the door switches using terminals supplied in the parts kit.

### Dome Light

- 7.9.3 The Painless harness contains two wires that will provide power (Pink #971) and ground (Black/White #912) to a DOME LIGHT. Pink wire #971 DOME LIGHT (B+) and Black/White wire #912 DOME LIGHT GROUD are both located at the same breakout as the LEFT DOOR JAMB SWITCH, FUEL PUMP B+, and TAIL SECTION.

### Courtesy Lights

- 7.9.4 The Painless harness provides wires to allow the use or reuse of COURTESY LIGHTS. The LEFT SIDE COURTESY LIGHT, or driver's side light, contain two wires: Pink #989 LEFT COURTESY LIGHT (B+) and Black/White #912 LEFT COURTESY LIGHT GROUND. The two wires will be labeled with a section label and are located in the same breakout as the HEADLIGHT SWITCH, SPEEDOMETER, WIPER MOTOR, AND TACHOMETER. The RIGHT SIDE COURTESY LIGHT, or passenger's side light, contains two wires: Pink #989 RIGHT COURTESY LIGHT (B+) and Black/White #912 RIGHT COURTESY LIGHT GROUND. The two wires will be labeled with a section label and are located in the same breakout as the HEATER RESISTOR, RADIO, RIGHT DOOR SWITCH, and FAN SWITCH. Splices can be made to the COURTESY LIGHTS using splices supplied in the parts kit.

### **Cigar. Lighter/Accessory Port**

- 7.9.5** Wires are provided in the Painless harness to wire the factory CIGARETTE LIGHTER/POWER PORT. Purple/White #903 CIGAR/ACCESSORY (B+) and Black #969 CIGAR/ACCESSORY GROUND will provide a constant power source. These wires can be found in the same breakout as the DIMMER SWITCH that goes to the steering column. Connections can be made to the factory CIGAR LIGHTER/ACCESSORY PORT pigtail using terminals supplied in the parts kit. Refer to **Figure 7.7.3** for the location of the factory pigtail coming from the A/C housing.

### **Radio**

- 7.9.6** Power and Ground for the radio are provided with the following three wires: White/Red #941 TO RADIO (IGN B+), which is the switched power to the RADIO, Purple/White #940 TO RADIO (B+), the constant battery power to the RADIO, and Black #969 RADIO GROUND, which of course is the ground for the RADIO. RADIO ILLUMINATION is powered and grounded through the following wires: Orange/Black #930 RADIO LIGHTING (B+) and Black #969 RADIO LIGHT GROUND. These five wires will be labeled "RADIO" with a section label and are located in the same breakout as the HEATER RESISTOR,, RIGHT DOOR SWITCH, and FAN SWITCH. Splices can be made to the RADIO using splices supplied in the parts kit.

### **Rear Wiper Switch**

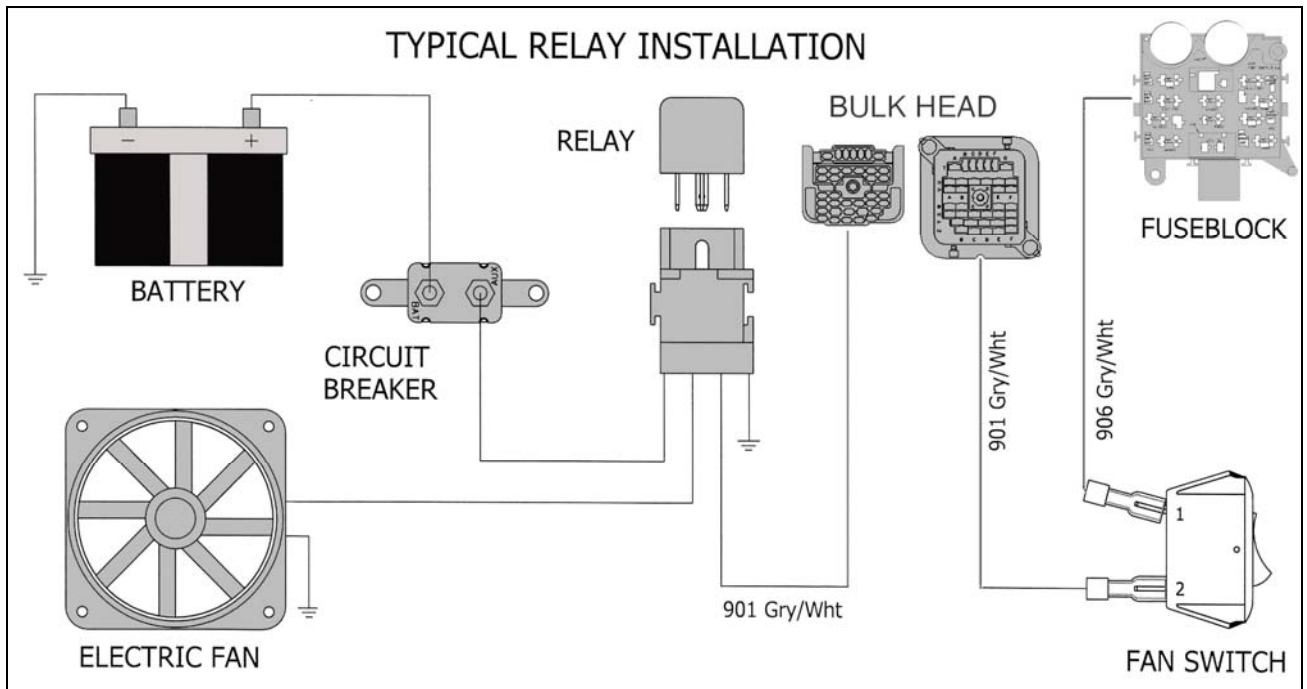
- 7.9.7** Wires have been incorporated into the Painless harness to accommodate those who have a rear wiper. For those using this feature, you must cut the factory connector to the REAR WIPER SWITCH from your factory harness. Cut just as you did with the column connectors, leaving the factory wires long enough to splice to. The factory wire color will match those found in the Painless harness which are as followed: Brown/White #984 REAR WIPER SWITCH TO REAR WIPER MOTOR, Green/White #981 REAR WIPER SWITCH (PARK) TO REAR WIPER MOTOR, Red/White #983 WASHER PUMP B+, and Black #969 REAR WIPER SWITCH GROUND. These four wires will be labeled "REAR WIPER SWITCH" with a section label and are located in the same breakout as the WIPER SWITCH.

### **Parking Brake**

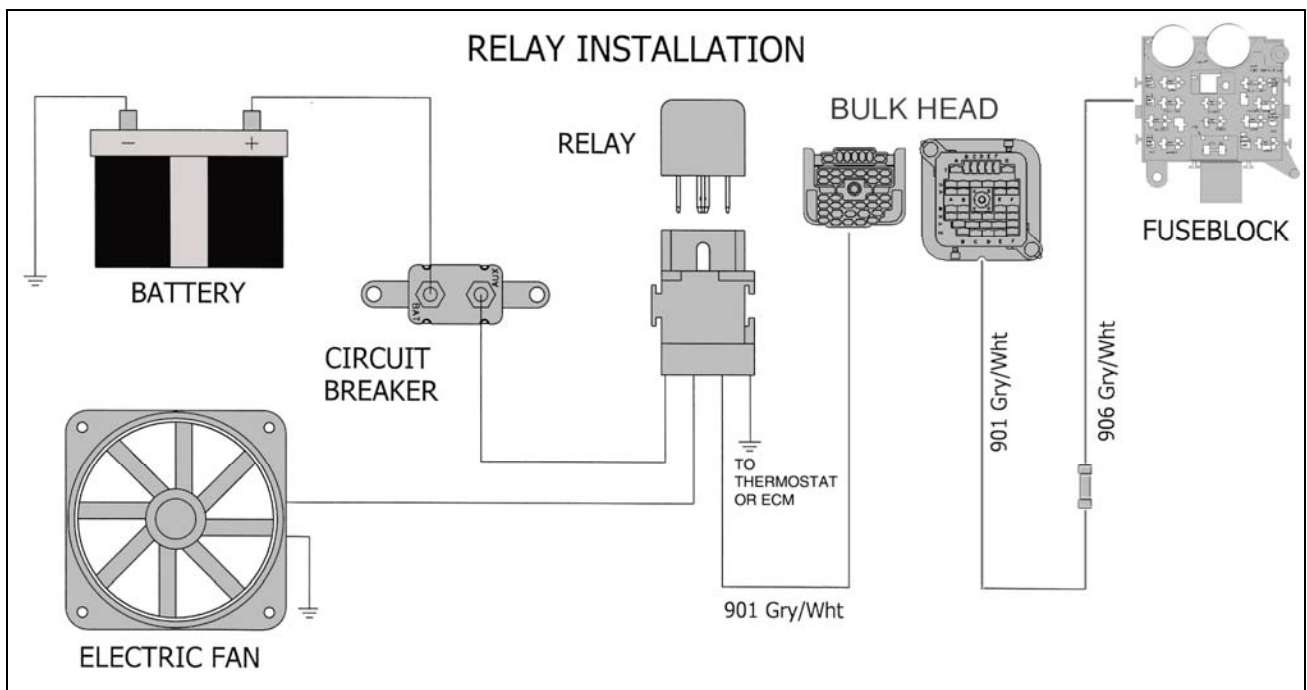
- 7.9.8** On the upper portion of the parking brake is the PARKING BRAKE SWITCH. This switch will illuminate the indicator light when the emergency brake is on. Connect Gray/Black wire #968 TO PARKING BRAKE SWITCH using terminals provided in the parts kit. This wire can be found with the L. DOOR JAMB and DOME LIGHT wires.

### **Fan Switch/Electric Fan(s)**

- 7.9.9** These two wires are for those running an electric cooling fan(s). Gray/White wire #906 TO COOLING FAN SWITCH (B+) provides a 12 volt power source to a switch. Gray/White wire #901 COOLING FAN RELAY ACTIVATION TO COOLING FAN SWITCH, provides power out to the electric fan relay(s). This is done through Gray/White wire #901 COOLING FAN RELAY ACTIVATION found in the ENGINE SECTION WIRING. See **Diagram 2** For those using a thermostat or an ECM to ground control the electric fan(s), wires #906 and #901 found in the FAN SWITCH SECTION can be spliced together to give #901 of the ENGINE SECTION a key on 12 volt source. See **Diagram 3**



**Diagram 2** Fan Switch Wiring



**Diagram 3** Fan Switch Wiring Used as a 12v Source

## 8.0 TAIL SECTION

### 8.1 Tail Lights- '87-'90 models

8.1.1 The LEFT TAIL LIGHT wiring has been pre-terminated and comes with a weather proof connector installed. This connector mates to the factory connector coming from the LEFT TAIL LIGHT.

8.1.2 The RIGHT TAIL LIGHT wiring has been pre-terminated and comes with a weather proof connector installed. These wires need to be routed across the top of the fuel tank, over to the RIGHT TAIL LIGHT. As with the LEFT TAIL LIGHT, the RIGHT TAIL LIGHT connector mates to the factory connector coming from the factory light.

#### '91 Models or Aftermarket Tail Lights with a 4 pin Connector

8.1.3 The original 4 pin connector must be reused; either re-pin this connector with the wires from the Painless harness or splice the original wires to the new wires.

8.1.4 If you're re-pinning the connector, remove the terminated wires from the 3 pin connector that came installed on your new Painless Harness and the wires from your factory 4 pin connector. This can be done by pressing the locking tangs of the terminal in and pulling the wire.

8.1.5 The 3 wires can now be re-pinned into the 4 pin connector from your original harness. See **Figure 8.1.5** for the pin outs

8.1.6 Extra terminals and seals have been provided in the event you destroy the terminals during removal from the 3 pin connector.

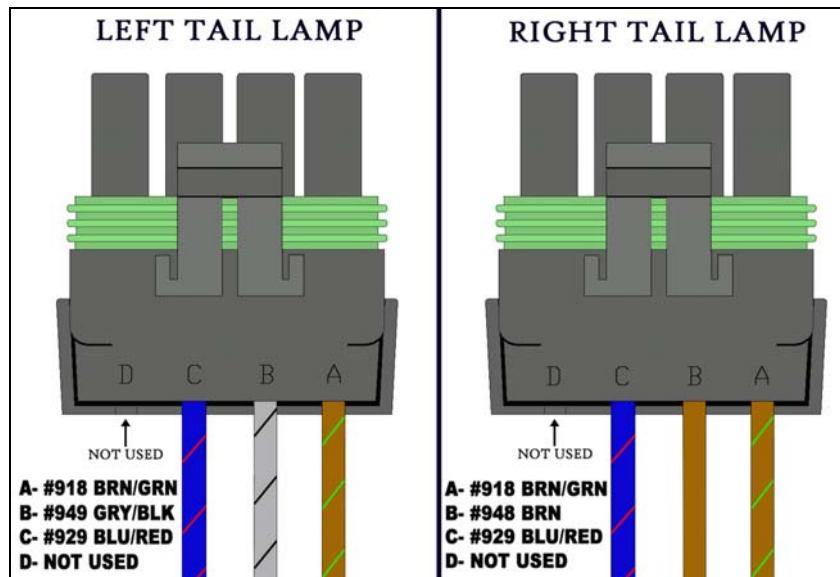


Figure 8.1.5 4 way Tail Lamp Connector

### 8.2 Fuel Tank

8.2.1 The FUEL TANK wiring has been pre-terminated and comes with a weather proof connector installed. This connector mates to the factory connector coming from the FUEL TANK.

### 8.3 Ground

8.3.1 All ground wires found in the tail section are all connected, through a series of splices, to the two wires labeled "GROUND".

8.3.2 These two wires come bare ended and have extra length to allow you to run the ground to where ever you choose.

8.3.3 When a suitable place for the GROUND wires has been found, cut the wires to length, strip the ends of both wires and double them up into a ring terminal from the parts kit. Look back on how the INTERIOR GROUND ring terminal was pre-installed for reference.

## 8.4 Plate light

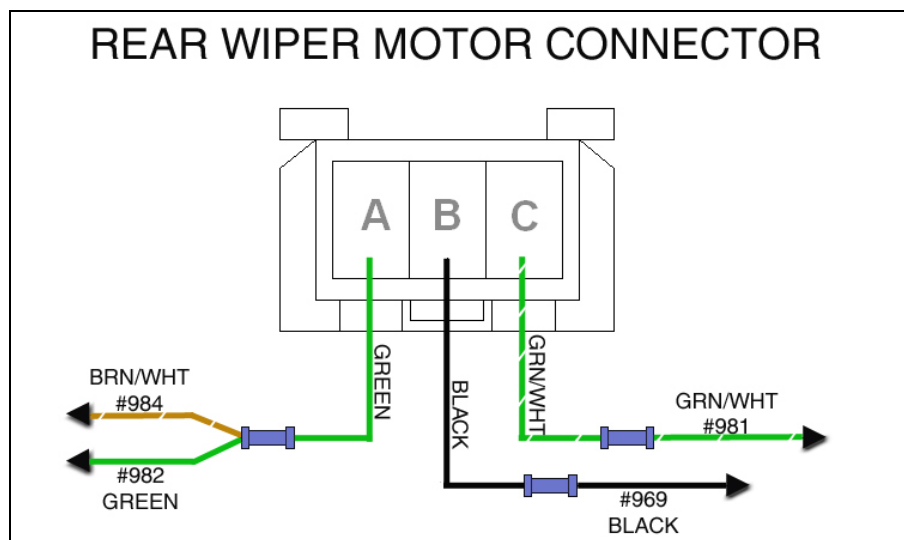
- 8.4.1 Route the two wires that make up the section of wires labeled "PLATE LIGHT" towards the license plate.
- 8.4.2 Blue/Red wire #962 LICENSE PLATE LIGHT (B+) will carry power when the tail/park lights are turned on at the Headlight Switch. The LICENSE PLATE LIGHT will be grounded through the Black wire #969 PLATE LIGHT GROUND. Both of these connections can be made by using splices included in the parts kit.

## 8.5 3<sup>rd</sup> Brake Light

- 8.5.1 Wires for a 3<sup>rd</sup> BRAKE LIGHT have been included in the Painless harness for vehicles so equipped.
- 8.5.2 Gray/Black wire #950 3<sup>rd</sup> BRAKE LIGHT (B+) will provide power when the brake pedal is pressed, while Black #969 3<sup>rd</sup> BRAKE LIGHT GROUND will of course provide the proper ground.

## 8.6 Rear Wiper Motor

- 8.6.1 The REAR WIPER MOTOR section consists of 4 wires: Green/White #981 REAR WIPER SWITCH (PARK) TO REAR WIPER MOTOR, Brown/White #984 REAR WIPER SWITCH TO REAR WIPER MOTOR, Black #969 REAR WIPER SWITCH GROUND, and Green #982 REAR WIPER MOTOR (B+)
- 8.6.2 Green #982 REAR WIPER MOTOR (B+) gets power from the 20 AMP inline fuse located near the fuse block.
- 8.6.3 These wires can either be connected by removing the factor connector from the OEM harness or hard wiring directly to the wires coming from the motor. If you chose to re-use the factory connector, cut the connector from the factory harness in the same manner the INDICATOR LIGHT and REAR WIPER SWITCH connectors were cut. see 7.5.3.
- 8.6.4 Connect the wires as **Diagram 4** shows. Take notice to wire #984 and wire #982 needing to be doubled up or spliced together.



**Diagram 4** *Rear Wiper Connections*

- 8.6.5 For those not connecting the REAR WIPER, Green #982 REAR WIPER MOTOR (B+) can be pulled from the TAIL SECTION, up to the dash. This wire can be used as an IGN. 12V ACCESSORY wire as long as the ACCESSORY does not require more than 20 AMPS. See 8.6.2



## 9.0 FRONT HARNESS

- 9.1 The FRONT HARNESS consists of two parts: a HEADLIGHT SECTION and a ENGINE SECTION
- 9.2 The HEADLIGHT SECTION was routed down the top of the driver's side fender in section 6.2.4 in this instruction manual.
- 9.3 The ENGINE SECTION will go across the top of the fire wall over to the passenger's side. It will be routed as connections are made.

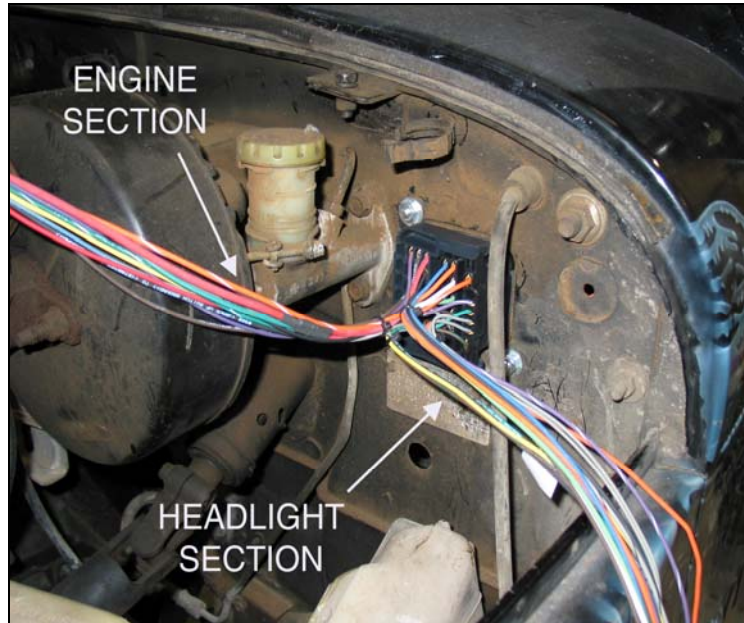


Figure 9.0 Front Harness

## 10.0 HEADLIGHT SECTION

### 10.1 Brake Warning

- 10.1.1 The factory connector will need to be reused in order to make this connection.
- 10.1.2 Create a pigtail in the same manner the INDICATOR LIGHT and REAR WIPER SWITCH connectors were cut. see 7.5.3.
- 10.1.3 Splice both wires of the BRAKE WARNING SWITCH pigtail to the 2 wires labeled "BRAKE WARN SWITCH". It does not matter which wire is spliced to each of the factory wires. see Figure 9.1.3

### 10.2 Fuel Injection Wire\*

- 10.2.1 The single 14 gauge Orange wire coming from the middle of the Bulk Head is to be used for those wanting to run/reuse the factory fuel delivery system. This wire will power all the factory fuel injection/delivery removed from your original harness. Even the factory carburetors were "computer" controlled.
- 10.2.2 This wire will also power up a Painless Stand Alone Fuel Injection Harness or Perfect Engine Management System.
- 10.2.3 This wire is an *un-protected* ignition 12 volt source coming directly from the IGNITION SWITCH and will need to be fused before use.

\* Reusing your factory wiring will require some electrical know how and lots of patience. Having the wiring schematics of the factory YJ injection system and even the factory carburetor system is a must. You will need to remove the entire factory engine wiring from your original harness. In the case that fuel injection or even the factory carburetion system is reused, some wires of the ENGINE SECTION may not be used or needed.

### 10.3 Washer Pump

10.3.1 The WASHER PUMP wires come pre-terminated with a connector installed. Plug the connector into the WASHER PUMP, located on the bottom of the washer fluid bottle. see **Figure 9.2.2**



Figure 9.1.3 Brake Warn Switch

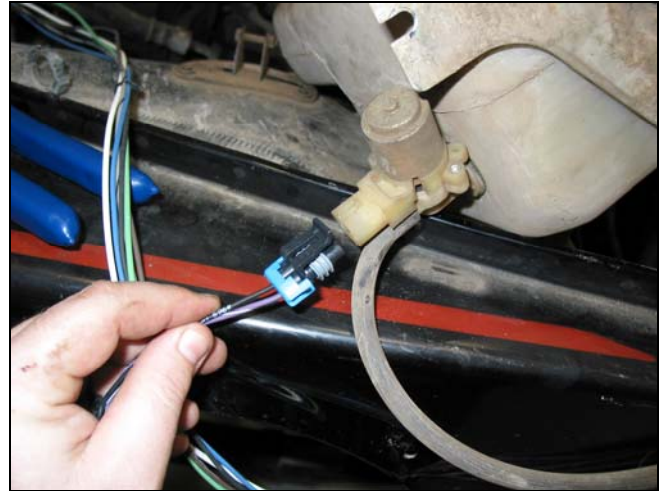


Figure 9.2.2 Washer Pump

### 10.4 Rear Washer Pump

10.4.1 On models equipped with a REAR WASHER PUMP, a pigtail using the original connector must be made. This pigtail will be made in the same manner the other pigtails from the factory harness have been made.

10.4.2 Match the wires of the Painless kit to the colors coming from the factory REAR WASHER PUMP connector

### 10.5 Horn

10.5.1 The HORN wiring consists of a single Orange wire that is pre-terminated with a connector installed.

10.5.2 Connect this wire to the tab coming from the HORN. see **Figure 10.4.2**



Figure 10.4.2 Horn



Figure 10.6.1 Turn/Park Light with Grease

## 10.6 Marker Lights

**10.6.1** The wiring for the front MARKER LIGHTS comes with a lamp socket pre-terminated with a bulb installed.

**10.6.2** Route the LEFT MARKER LIGHT over to the driver's side light and install the socket.

**10.6.3** The same is done for the RIGHT MARKER LIGHT. Route the lamp socket to the MARKER LIGHT and connect.

## 10.7 Turn/Park Lights

**10.7.1** The TURN/PARK lights will need to have the covers removed and the terminals sealed with dielectric compound/grease. The covers can be removed by lifting the locking tabs of the cover. With the back of the socket sealed, snap the cover back on and smear a small amount of dielectric compound/grease to the inside of the lamp socket where the bulb contacts the terminals. Sealing the connector will help prevent the terminals from corroding in the weather. see **Figure 10.6.1**

**10.7.2** Sealing the connectors is not absolutely necessary, but it is highly recommended. It will extend the life of the sockets and in turn, the life of the harness.

**10.7.3** Before the installation of the LEFT or RIGHT TURN/PARK LIGHT sockets, ensure bulbs have been installed. TURN SIGNALS will not work properly unless all bulbs are installed

## 10.8 Headlights

**10.8.1** Wiring for each HEADLIGHT has a three pin connector pre-installed. This connector needs to be plugged into the back of the HEADLIGHT. The tabs on the lights tend to bend over, make certain the connector is going on straight. See **Figure 10.7.1**



**Figure 10.7.1** Headlight Connection

## 10.9 Front Ground

**10.9.1** The FRONT GROUND wires will provide a good ground to all lamp sockets, connectors, and ground wire located in the FRONT HARNESS.

**10.9.2** The FRONT GROUND wires can be found close to where the HEADLIGHT SECTION passed through the core support.

**10.9.3** Attach the ring terminal of the FRONT GROUND wires to an existing nut or bolt on the core support or frame. Remove any paint, dirt, or grease from the ground contact area to ensure a good clean ground.

## 11.0 ENGINE SECTION

- Due to the numerous engine and transmission options available, this portion of the Painless harness is all opened ended wire. All terminals needed to make the correct connections can be found in the parts kit, supplied with this harness.
- A factory schematic of the engine and/or transmission being used may be necessary in order to make the correct connections.
- With so many engine and transmission options available, this portion of the instruction manual will not be as specific as the previous sections.
- Some of the zip ties on the harness may need to be cut in order to route wires to their correct location.

### 11.1 Back Up & Neutral Safety Switch (Mopar\*)

\*the following instructions only pertain to those using a Mopar Neutral Safety switch. Ford and GM NEUTRAL SAFETY SWITCHES use the Start signal wire coming from the Ignition Switch, #919 Grn in this harness.

- 11.1.1 This section of wires contains 4 wires, and should be connected according to the printed description on each.
- 11.1.2 Black/Yellow #942 "4WD SWT" connects to the 4 wheel drive switch. This is a ground wire to the 4wd indicator lamp.
- 11.1.3 Black #980 "PARK/NEUTRAL SWITCH to STARTER SOLENOID" will ground the starter solenoid when the transmission is in Park or Neutral. This makes it impossible to start the engine while in gear.
- 11.1.4 Yellow #958 "BACK UP SWITCH (B+)" provides power to the BACK UP switch.
- 11.1.5 Brown/Green #956 "BACK UP LIGHT SWITCH OUTPUT" provides power out of the BACK UP SWITCH to the reverse lights.

### 11.2 Coil

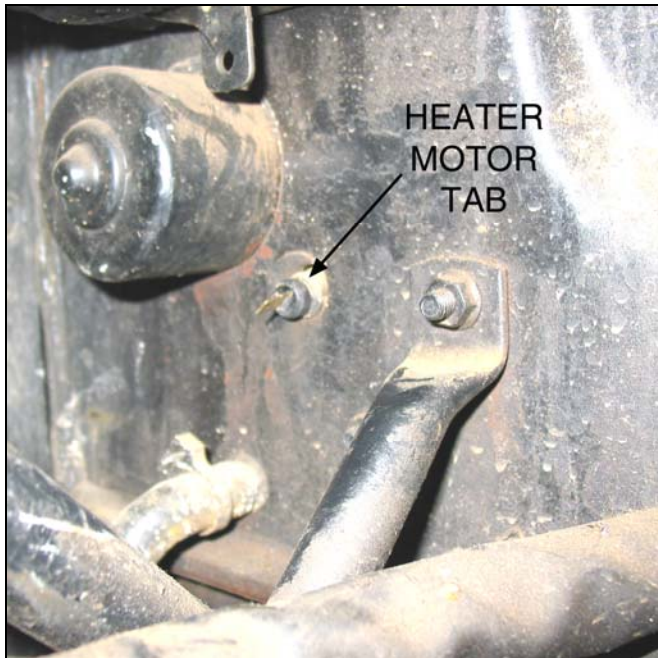
- 11.2.1 Wiring to the COIL is done with 3 wires.
- 11.2.2 Yellow #920 "TO COIL "+" provides a switched 12volt source to the COIL.
- 11.2.3 Brown #981 "COIL"+" to STARTER "I" TERM." Provides 12volt source from the STARTER to the COIL during start up. Green/White #923 "TACH SIGNAL" connects to the "-" side of the COIL. This will provide a signal to the TACH.
- 11.2.4 Unlike all other Painless Performance Chassis Harnesses, this kit does not contain a ballast resistor. In the case that a ballast resistor is needed, refer to Painless part # RU-11.

### 11.3 Electric Choke

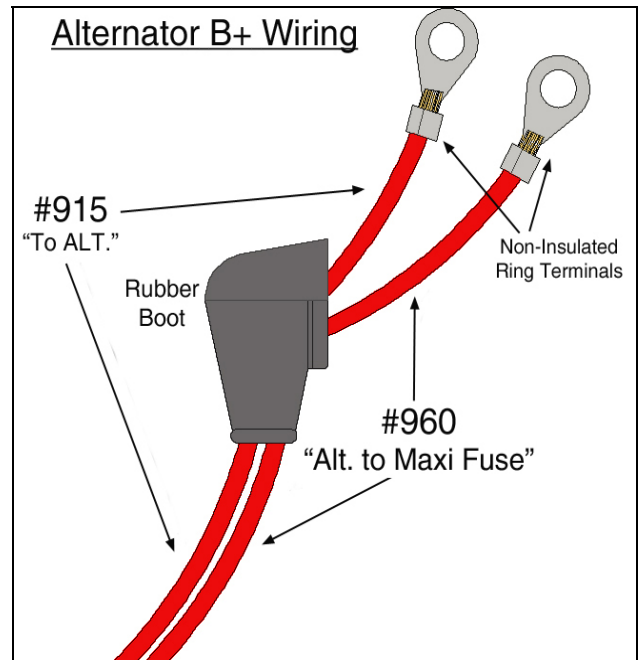
- 11.3.1 Connection to an ELECTRIC CHOKE can be made using Red #954 "TO ELECTIC CHOKE"

### 11.4 Heater Motor

- 11.4.1 Locate the tab for the heater motor.
- 11.4.2 This tab can be found on the fire wall, under the battery tray. See **Figure 11.4.2**
- 11.4.3 Connect Orange/White #967 "HEATER MOTOR (B+)" to the tab on the fire wall.



**Figure 11.4.2** Heater Motor Tab



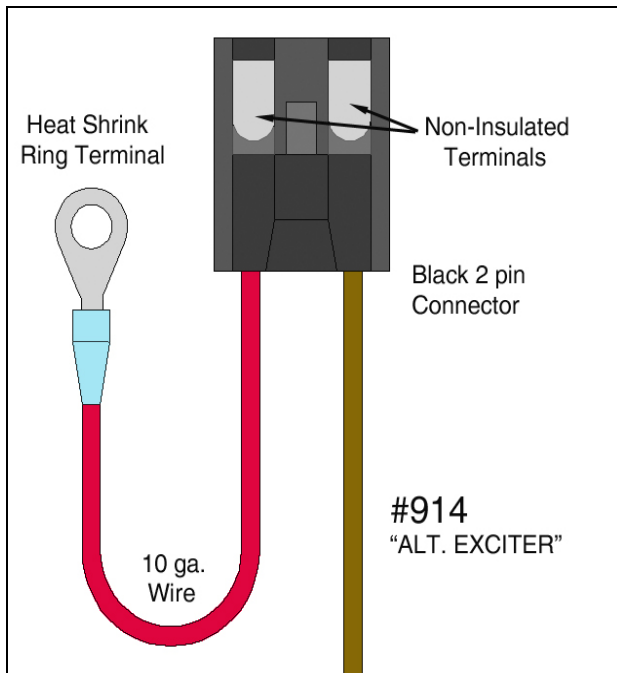
**Diagram 5** Alternator B+ Wiring

### 11.5 Alternator Wiring

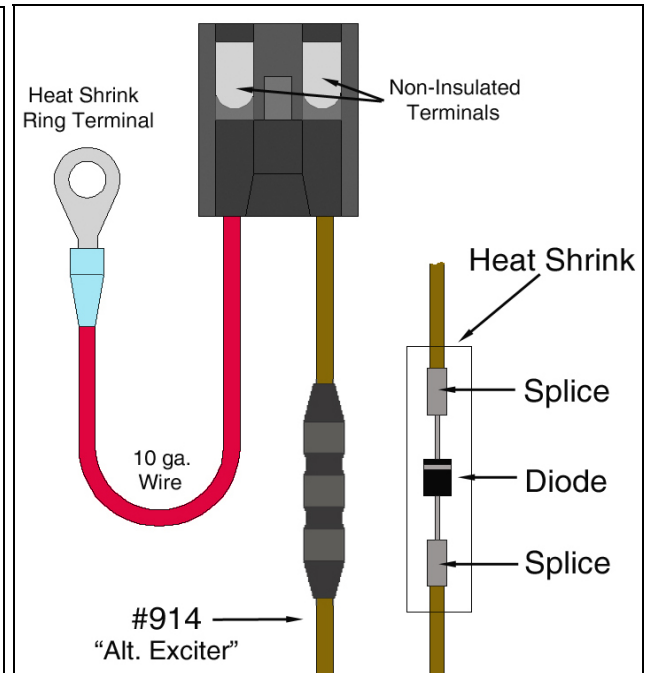
- Drawings for Ford, Mopar, and GM Alternators can be found in the back of this manual.
- 11.5.1** The Painless harness has three wires for the ALTERNATOR connections.
- 11.5.2** Route all three wires, two 10 gauge Red wires and one 14 gauge Brown wire, to the ALTERNATOR and cut to length.
- 11.5.3** Red wire #915 "TO ALT" needs to have the alternator boot installed and then a non-insulated ring terminal installed. This wire connects to the Alternator Output (B+) post. Refer to **Diagram 5**
- 11.5.4** Red wire #960 "ALTERNATOR to MAXI FUSE" is provided for those running high output Alternators. This wire needs to be connected in the same manner as wire #915. Refer to **Diagram 5**
- 11.5.5** Brown #914 "to Alt. Exciter" is a switched 12 volt source.

#### **GM 2 Wire Alternator**

- 11.5.6** Heat shrinkable ring terminals and a connector with terminals have been supplied for those running a GM 2 wire ALTERNATOR.
- 11.5.7** 10 gauge wire cut from the #915 or #960 wires should be used when terminating this connector. This Red wire will connect to the B+ post of the ALTERNATOR with wires #915 and #960. Brown #914 will be installed into the connector see **Diagram 6** and **Diagram 7**
- 11.5.8** In some cases, engine run on continues when the ignition is turned off. In the event that this happens, the diode provided in the parts kit will need to be installed. The diode will need to be installed with the stripe towards/closest to the connector. see **Diagram 7** Non-insulated splices and a piece of heat shrink have been provided with the diode.



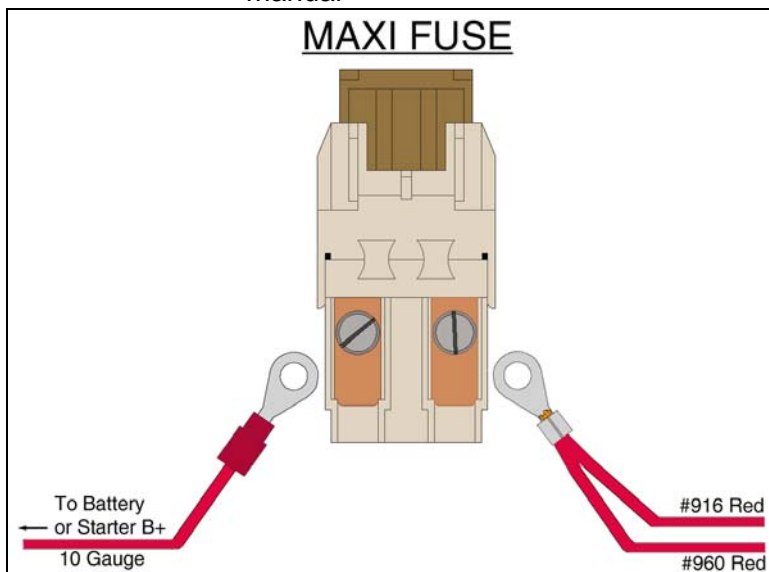
**Diagram 6** GM 2 Wire Alt. Connector



**Diagram 7** GM 2 Wire Alt. Conn. with Diode

### 11.6 Maxi Fuse

- 11.6.1 Locate the MAXI FUSE BASE, MAXI FUSE, and COVER in the Parts kit included with your Painless harness.
- 11.6.2 Decide if you are going to pull B+ power directly from the battery or from the B+ side of the STARTER SOLENOID. The Painless harness and all **Diagrams** in this manual show getting power from the STARTER SOLENOID.
- 11.6.3 Mount the Maxi fuse base into an easy accessible place as close to the battery or Starter B+ as you can.
- 11.6.4 Locate the two 10 Gauge Red wires in the STARTER SOLENOID section. These 2 wires #916 and #960, if a high output ALTERNATOR is being used, will be doubled up on one side of the MAXI FUSE. Use the large non-insulated ring terminal in the parts kit to double up the two 10 gauge wires. The other side of the Maxi fuse needs to have a wire running to the power source, either the battery or Starter B+. This wire needs to be at least a 10 gauge wire. Install the MAXI FUSE COVER after connections are made. See **Diagram 8** & the **Start/Run Diagrams** in the back of this manual



**Diagram 8** Maxi Fuse

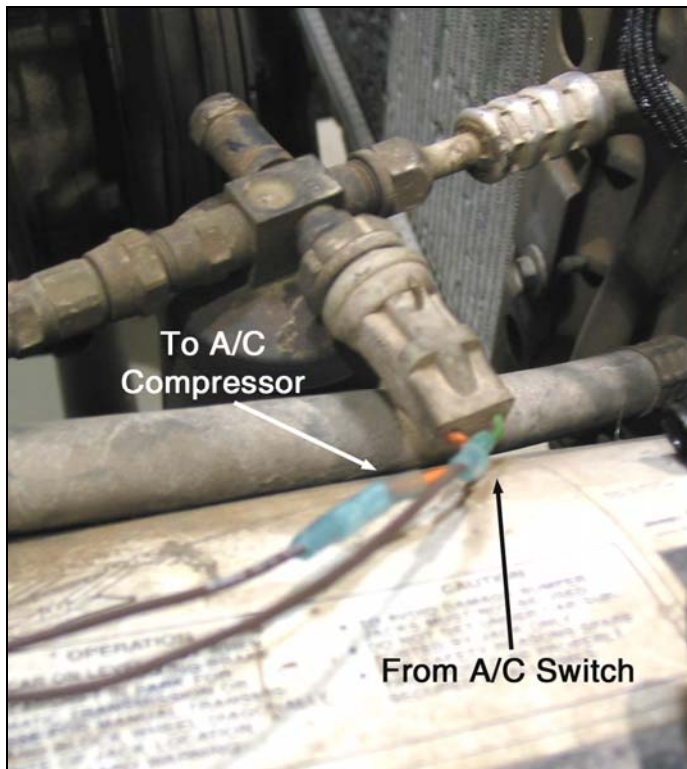
## 11.7 Starter Solenoid

- 11.7.1 Route the remaining 3 wires (Blk, Grn, and Brn) located in the STARTER SOLENOID section to the STARTER SOLENOID.
- 11.7.2 Black wire #980 "PARK/NEUTRAL TO STARTER RELAY GROUND" will connect to "G: on the Starter Relay. This wire will only be used on those using a Mopar Starter Relay.
- 11.7.3 Brown wire #981 "COIL"+" TO STARTER "I" TERM." Will connect to the "I" terminal of the STARTER SOLENOID or to the BAL. terminal of the Mopar relay.
- 11.7.4 Green wire #919 "TO STARTER (START)" will connect to the "S" terminal of the STARTER SOLENOID or the the "IGN." terminal on a Mopar relay. This wire is also used in wiring a Ford or GM NEUTRAL SAFETY SWITCH.

\*If using a MOPAR starter relay, make sure you are using the SR-14 relay

## 11.8 Sender Wires, Cooling Fan Relay, & A/C Compressor

- 11.8.1 Purple wire #921 "TEMP. SENDNING UNIT" will connect to the engine Coolant Temperature Sensor. This will provide a signal for the Temperature gauge.
- 11.8.2 Lt.Blue wire #922 "OIL PRESSURE SENDING UNIT" will connect to the oil pressure sending unit. This will provide a signal for the Oil Pressure gauge.
- 11.8.3 Gray/White wire #901 "TO COOLING FAN RELAY ACTIVATION" is a 12volt activation wire that comes from the Fan switch. see **Section 7.9.9**
- 11.8.4 Brown wire #902 "A/C COMPRESSOR ACTIVATION" will connect to one side of the A/C pressure switch. Connect the other side of the A/C Pressure Switch to the A/C compressor. This can be done using wire cut from #902. See **Figure 11.8.4**



**Figure 11.8.4** A/C Pressure Switch

## 12.0 TESTING THE SYSTEM

- 12.1 Use a small (10 amp or less) battery charger to power up the vehicle for the first time to test the circuits. If there is a problem anywhere, the battery charger's low amperage and internal circuit breaker will provide circuit protection.
- 12.2 Connect the battery charger's NEGATIVE cable to the automobile chassis or engine block and its POSITIVE cable to the automobile's positive battery terminal lug.
- 12.3 INDIVIDUALLY turn on each light, ignition, wiper circuit, etc. and check for proper operation.  
*Note: The turn signals will not flash properly if you do not have both the front and rear bulbs installed and connected.*
- 12.4 After all circuits have been checked, disconnect the battery charger and attach the vehicles battery cables to the battery.

## 13.0 WIRE INDEX

- 13.1 In each section, connect the wire, as identified by its wire color, to the appropriate item in the CONNECT TO column. The **Wire Index** is divided into sections that correspond to the sections of your wire harness. (TURN SWITCH SECTION, DIMMER SWITCH SECTION, etc.). The index is divided vertically into six columns. COLOR, GAUGE, NUMBER, CONNECT TO, ORIGIN, and SECTION OF ORIGIN.

In some places ORIGIN, and SECTION OF ORIGIN are merged together. This means that this wire is part or a series of splices to other sections and components.

The columns labeled ORIGIN and SECTION OF ORIGIN are for your reference ONLY. The items in these columns tell you where each wire originates (ORIGIN) and from which section (SECTION OF ORIGIN) of the harness.

The column labeled NO. contains a 900-series number that is used to identify various wires in the wiring diagrams that are a part of these instructions. Only printed wires will have a 900-series number. The majority of those without a number come pre terminated with a connector installed. **These pre-connected wires are identified by an asterisk (\*) next to the SECTION.**



COLOR	GA.	WIRE #	CONNECTS TO	WIRE STARTING POINT	SECTION OF STARTING POINT
<b>Interior Ground*</b>					
BLK	16	-	Interior ground	All Interior Ground wires	
BLK	14	-	Interior ground	All Interior Ground wires	
<b>Fuel Pump B+</b>					
ORG	14	947	Output of Fuel Pump Relay	Fuel Tank	Tail Section
<b>Left Door Jamb</b>					
BLK/WHT	18	987	Left Door Jamb Switch	Ill. Dimmer Switch and Dome/Courtesy Light Grounds	
<b>Parking Brake</b>					
GRY/BLK	18	968	Parking Brake Switch	Brake Warning Indicator	Left Column Connector
<b>Dome Light</b>					
PNK	18	971	Dome Light (B+)	Fuse Block	Fuse Block
BLK/WHT	18	912	Dome Light Ground	Door Switches & Ill. Dimmer Switch	
<b>Dimmer Switch*</b>					
TAN/BLK	14	-	Headlight Low	Headlight Switch	Headlight Switch
WHT	14	-	Headlight High	Headlight High	Headlight Section
LT.GRN	14	-	Headlight Low	Headlight Low	Headlight Section
BRN/WHT	14	-	Headlight High	Headlight Switch	Headlight Switch
<b>Illumination Dimmer Switch</b>					
BLU	18	-	Illumination Dimmer Switch B+	Headlight Switch	Headlight Switch
ORG	16	-	Gauge/Panel Light B+	B+ for all Gauge/Panel Lights	
BLK	18	-	Illumination Dimmer Switch Ground	Interior Ground	Interior Ground
BLK/WHT	18	-	Interior Lighting Ground	Door switches & Dome/Courtesy Lights	

COLOR	GA.	WIRE #	CONNECTS TO	WIRE STARTING POINT	SECTION OF STARTING POINT
<b>Headlight Switch</b>					
TAN/BLK	14	-	Headlight Low	Dimmer Switch	Dimmer Switch
RED	12	-	Headlight Switch B+	Fuse Block	Fuse Block
RED/BLK	12	-	Headlight Switch B+	Fuse Block	Fuse Block
BRN/WHT	14	-	Headlight High	Dimmer Switch	Dimmer Switch
BLU	16	-	Illumination Dimmer Switch B+	Illumination Dimmer Switch	Illumination Dimmer Switch
BLU	16	-	Tail Light B+	Plate & Tail Lights	Tail Section
<b>Tachometer*</b>					
GRN/WHT	18	-	Tach Signal	Coil "-"	Engine Section
ORG/BLK	18	-	Tach Light B+	Illumination Dimmer Switch	Illumination Dimmer Switch
BLK	18	-	Ground	Interior Ground	Interior Ground
WHT/BLK	18	-	Gauge B+	Fuse Block	Fuse Block
<b>Speedometer*</b>					
ORG/BLK	18	-	Gauge Light B+	Illumination Dimmer Switch	Illumination Dimmer Switch
BLK	18	-	Gauge Light Ground	Interior Ground	Interior Ground
<b>Wiper Motor*</b>					
BLK	18	-	Ground	Interior Ground	Interior Ground
TAN/BLK	16	-	Wipers Down	Wiper Switch	Wiper Switch
WHT/BLK	16	-	Low	Wiper Switch	Wiper Switch
LTGN/BLK	16	-	Wiper Motor B+	Wiper Switch	Wiper Switch
BLU/WHT	16	-	High	Wiper Switch	Wiper Switch

COLOR	GA.	WIRE #	CONNECTS TO	WIRE STARTING POINT	SECTION OF STARTING POINT
<b>Left Courtesy Light</b>					
PNK	18	989	Left Courtesy Light B+	Fuse Block	Fuse Block
BLK/WHT	18	912	Left Courtesy Light Ground	Door Switches & Ill. Dimmer Switch	
<b>Turn Switch*</b>					
ORG/BLK	18	-	Gear Indicator Light	Illumination Dimmer Switch	Illumination Dimmer Switch
PPL/WHT	14	-	Hazard Flasher	Fuse Block	Fuse Block
GRY	14	-	Turn Flasher	Fuse Block	Fuse Block
GRY/BLK	18	937	Left Turn Indicator	Left Column Connector	Left Column Connector
GRY/BLK	16	-	Left Turn Signal	Left Turn Signal	Headlight Section
BRN	18	938	Right Turn Indicator	Right Column Connector	Right Column Connector
BRN	16	-	Right Turn Signal	Right Turn Signal	Headlight Section
GRY/BLK	16	949	Left Rear Turn Signal	Left Rear Tail Lamp	Tail Section
BRN	16	948	Right Rear Turn Signal	Right Rear Tail Lamp	Tail Section
ORG/BLK	18	-	Horn Ground	Horn Relay	Fuse Block
LTBL/BLK	16	-	Brake Switch Output	Brake Switch	Brake Switch
<b>Left Indicator Circuit Connector</b>					
GRY/BLK	18	937	Left Turn Indicator	Turn Switch	Turn Switch
WHT	18	936	High Beam Indicator	Dimmer Switch	Dimmer Switch
WHT/BLK	18	935	Indicator Lights B+	Fuse Block	Fuse Block
GRY/BLK	18	968	Brake Warn Indicator	Brake Warn Switch	Headlight Section

COLOR	GA.	WIRE #	CONNECTS TO	WIRE STARTING POINT	SECTION OF STARTING POINT
<b>Right Indicator Circuit Connector</b>					
ORG/BLK	18	930	Panel Lighting B+	Illumination Dimmer Switch	Illumination Dimmer Switch
BLK/YLW	18	942	4x4 Indicator	4x4 switch	Backup & Neutral Safety Switch
BRN	18	938	Right Turn Indicator	Turn Switch	Turn Switch
BLK	18	969	Indicator Lights Ground	Interior Ground	Interior Ground
<b>Ignition Switch* (white connector)</b>					
GRN	14	-	Start	Starter	Engine Section
PPL	12	-	Accessory B+	Fuse Block	Fuse Block
ORG	12	-	Ignition B+	Fuse Block	Fuse Block
YLW	14	-	Coil B+	Fuse Block	Fuse Block
<b>Ignition Switch* (black connector)</b>					
ORG	14	-	Fuel Injection	Bulk Head	Bulk Head
GRY/BLK	18	-	Brake Switch	Brake Warn Switch	Headlight Section
RED	12	-	B+	Fuse Block	Fuse Block
<b>Brake Switch*</b>					
PNK/BLK	16	-	B+	Fuse Block	Fuse Block
LTBL/BK	16	-	Brake Switch Output	Turn Switch	Turn Switch
<b>Rear Wiper Switch</b>					
BRN/WHT	16	984	B+	Rear Wiper Motor	Tail Section
GRN/WHT	16	981	Park	Rear Wiper Motor	Tail Section
RED/WHT	16	983	Washer Pump B+	Washer Pump	Headlight Section
BLK	18	969	Ground	Interior Ground	Interior Ground

COLOR	GA.	WIRE #	CONNECTS TO	WIRE STARTING POINT	SECTION OF STARTING POINT
<b>Wiper Switch*</b>					
LTGN/BLK	14	-	B+	Fuse Block	Fuse Block
PPL/WHT	16	-	Washer B+	Washer Pump	Headlight Section
BLU/WHT	16	-	High	Wiper Motor	Wiper Motor
LTGN/BLK	16	-	Wiper Motor B+	Fuse Block	Fuse Block
TAN/BLK	16	-	Wipers Down	Wiper Switch	Wiper Switch
WHT/BLK	16	-	Low	Wiper Switch	Wiper Switch
BLK	18	-	Ground	Interior Ground	Interior Ground
<b>Gauge Cluster*</b>					
PPL	18	-	Coolant Temp.	Coolant Temp Sensor	Engine Section
WHT/BLK	18	-	Gauge B+	Fuse Block	Fuse Block
WHT/BLK	18	-	Gauge B+	Fuse Block	Fuse Block
BLK	18	-	Ground	Interior Ground	Interior Ground
TAN/BLK	18	-	Fuel Level	Fuel Tank	Tail Section
LTBLU	18	-	Oil Pressure	Oil Pressure Sender	Engine Section
PNK	18	-	Clock B+	Fuse Block	Fuse Block
ORG/BLK	18	-	Gauge Illumination B+	Illumination Dimmer Switch	Illumination Dimmer Switch
ORG/BLK	18	-	Gauge Illumination B+	Illumination Dimmer Switch	Illumination Dimmer Switch
<b>Right Hand Courtesy Light</b>					
PNK	18	989	Right Courtesy Light B+	Fuse Block	Fuse Block
BLK/WHT	18	912	Right Courtesy Light Ground	Door Switches & Ill. Dimmer Switch	

COLOR	GA.	WIRE #	CONNECTS TO	WIRE STARTING POINT	SECTION OF STARTING POINT
<b>Heater Micro Switch* and HVAC Panel Lamp</b>					
WHT	14	900	Heater B+	Heater Switch	HVAC Section
WHT	14	998	Micro Switch B+	Fuse Block	Fuse Block
ORG/BLK	18	930	Panel Illumination B+	Illumination Dimmer Switch	Illumination Dimmer Switch
BLK	18	969	Panel Light Ground	Interior Ground	Interior Ground
<b>Heater Switch*</b>					
ORG/WHT	16	-	Heater Motor B+	Heater Motor	Engine Section
WHT/BLK	14	-	High	Heater Resistor	Heater Resistor
LTGRN	16	-	Low.	Heater Resistor	Heater Resistor
TAN	16	-	Medium	Heater Resistor	Heater Resistor
WHT	14	900	Heater B+	Heater Micro Switch	HVAC Section
<b>A/C Switch</b>					
BLK	16	902	A/C Compressor Activation	A/C Compressor	Engine Section
BRN	16	-	A/C B+	Fuse Block	Fuse Block
<b>Fan Switch</b>					
GRY/WHT	18	906	Cooling Fan Switch B+	Fuse Block	Fuse Block
GRY/WHT	18	901	Cooling Fan Activation	Cooling Fan Relay	Engine Section
<b>Heater Resistor*</b>					
WHT/BLK	14	-	High	Heater Switch	HVAC Section
LTGRN	16	-	Low.	Heater Switch	HVAC Section
TAN	16	-	Medium	Heater Switch	HVAC Section

COLOR	GA.	WIRE #	CONNECTS TO	WIRE STARTING POINT	SECTION OF STARTING POINT
<b>Cigar. Lighter/Accessory</b>					
PPL/WHT	16	903	Cigar./Accessory B+	Fuse Block	Fuse Block
BLK	18	969	Cigar./Accessory Ground	Interior Ground	Interior Ground
<b>Radio</b>					
WHT/RED	16	941	Radio (IGN. B+)	Fuse Block	Fuse Block
PPL/WHT	18	940	Radio B+	Fuse Block	Fuse Block
ORG/BLK	18	930	Radio Illumination B+	Illumination Dimmer Switch	Illumination Dimmer Switch
BLK	18	969	Radio Illumination Ground	Interior Ground	Interior Ground
<b>Right Door Jamb</b>					
BLK/WHT	18	988	Right Door Jamb Switch	Ill. Dimmer Switch and Dome/Courtesy Lights Grounds	
<b>Rear Ground</b>					
BLK	16	969	Rear Ground	All Rear Ground Wires	
BLK	16	969	Rear Ground	All Rear Ground Wires	
<b>Left Rear*</b>					
BLU/RED	18	929	Left Tail Light	Headlight Switch	Headlight Switch
GRY/BLK	16	949	Left Turn/Brake	Turn Switch	Turn Switch
BRN/GRN	18	918	Left Reverse Light	Back Up switch	Backup & Neutral Safety Switch
<b>Fuel Sender*</b>					
TAN/BLK	18	939	Fuel Sender	Gauge Cluster	Gauge Cluster
ORG	14	947	Fuel Pump B+	Fuel Pump B+	Fuel Pump B+
BLK	16	969	Ground	Rear Ground	Rear Ground

COLOR	GA.	WIRE #	CONNECTS TO	WIRE STARTING POINT	SECTION OF STARTING POINT
<b>3rd Brake Light</b>					
GRY/BLK	18	950	3rd Brake Light B+	Brake Switch	Brake Switch
BLK	18	969	3rd Brake Light Ground	Rear Ground	Rear Ground
<b>Rear Wiper Motor</b>					
BLK	18	969	Ground	Rear Ground	Rear Ground
GRN	14	982	B+ To Wiper Motor	Ignition Switch	Ignition Switch
BRN/WHT	16	984	B+ To Switch	Rear Wiper Switch	Rear Wiper Switch
GRN/WHT	16	981	Park	Rear Wiper Switch	Rear Wiper Switch
<b>Plate Light</b>					
BLU/RED	18	962	Plate Light B+	Headlight Switch	Headlight Switch
BLK	18	969	Plate Light Ground	Rear Ground	Rear Ground
<b>Right Rear*</b>					
BLU/RED	18	929	Right Tail Light	Headlight Switch	Headlight Switch
BRN	16	948	Right Turn/Brake	Turn Switch	Turn Switch
BRN/GRN	18	918	Right Reverse Light	Back Up switch	Backup & Neutral Safety Switch
<b>Backup &amp; Neutral Safety Switch</b>					
BLK/YLW	16	942	4X4 Switch	Right Indicator Circuit Connector	Right Indicator Circuit Connector
BLK	16	980	Starter Solenoid Ground	Starter Solenoid	Starter Solenoid
YLW	16	958	Back Up Switch B+	Fuse Block	Fuse Block
BRN/GRN	16	956	Back Up Switch Output	Reverse Lights	Tail Section
<b>Choke</b>					
RED	16	954	Electric Choke	Fuse Block	Fuse Block

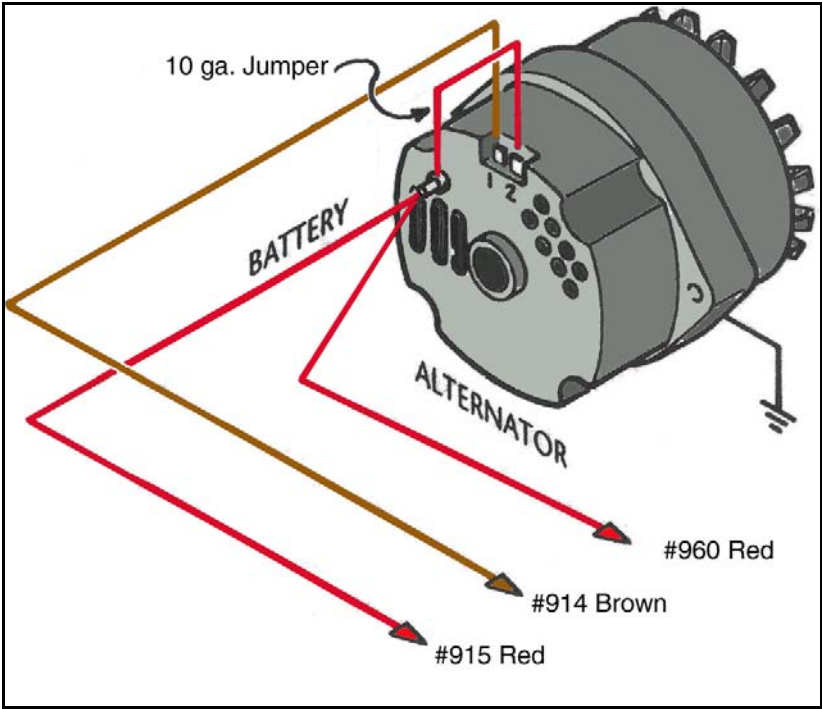


COLOR	GA.	WIRE #	CONNECTS TO	WIRE STARTING POINT	SECTION OF STARTING POINT
<b>Coil</b>					
YLW	16	920	Coil "+"	Fuse Block	Fuse Block
GRN/WHT	18	923	Tach Signal (Coil "-")	Tachometer	Tachometer
BRN	16	981	Coil "+"	Starter Solenoid	Starter Solenoid
<b>Heater Motor*</b>					
ORG/WHT	14	967	Heater Motor B+	Heater Switch	HVAC Section
<b>Starter Solenoid and Maxi Fuse</b>					
BLK	16	980	Ground	Neutral Safety Switch	Backup & Neutral Safety Switch
GRN	14	919	Start/"S" Term	Ignition Switch	Ignition Switch
BRN	16	981	Ign. B+/"I" Term.	Coil "+"	Coil
RED	10	916	Maxi Fuse B+	Fuse Block	Fuse Block
RED	10	960	Maxi Fuse B+	Alternator Output/B+	Alternator
<b>Alternator</b>					
RED	10	915	Alternator Output/B+	Fuse Block	Fuse Block
RED	10	960	Alternator Output/B+	Starter Solenoid	Starter Solenoid
BRN	14	914	Alternator Exciter	Fuse Block	Fuse Block
<b>Sender Wires</b>					
PPL	18	921	Coolant Temp. Sensor	Gauge Cluster	Gauge Cluster
LT.BLU	18	922	Oil Pressure Sender	Gauge Cluster	Gauge Cluster
BRN	16	902	A/C Compressor	A/C Switch	A/C Switch
GRY/WHT	18	901	Fan Relay Activation	Cooling Fan Switch	Cooling Fan Switch

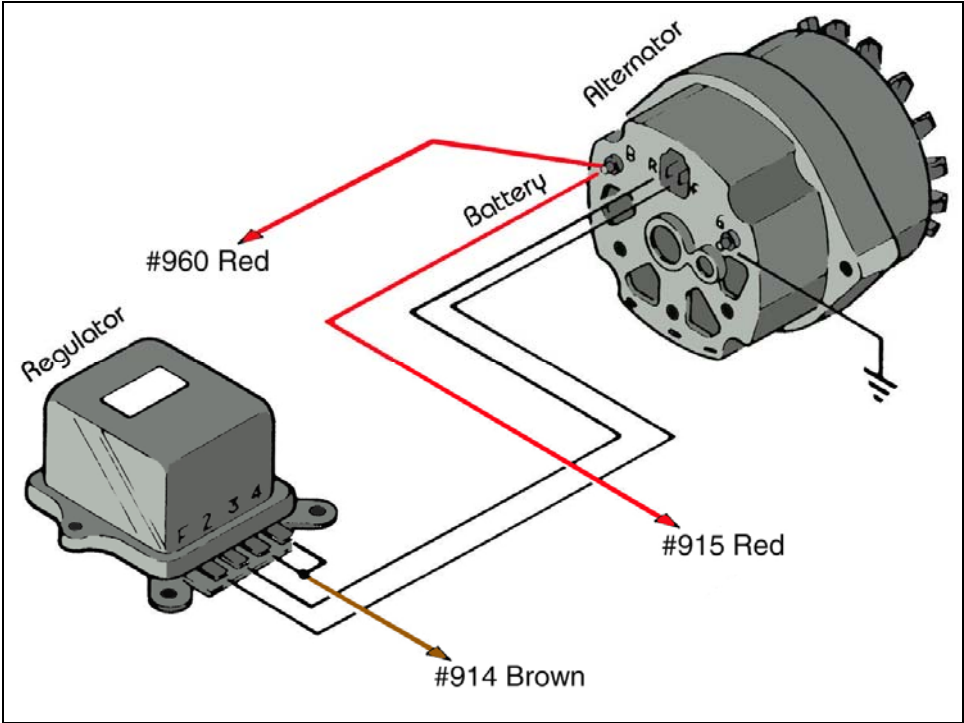
COLOR	GA.	WIRE #	CONNECTS TO	WIRE STARTING POINT	SECTION OF STARTING POINT
<b>Fuel Injection</b>					
ORG	14	-	IGN. 12v for Fuel Injection	Ignition Switch	Ignition Switch
<b>Brake Warning Switch</b>					
GRY	18	-	Brake Warning Switch	Ignition Switch	Ignition Switch
GRY	18	-	Brake Warning Switch	Brake Warning Light	Left Indicator Circuit Connector
<b>Horn*</b>					
ORG	14	-	Horn B+	Horn Relay	Fuse Block
<b>Washer Motor*</b>					
PPL/WHT	16	983	Washer Ground B+	Wiper Switch	Wiper Switch
BLK	18	969	Washer Pump Ground	Front Ground	Front Ground
PPL/ORG	16	983	Rear Washer Pump B+	Rear Wiper Switch	Rear Wiper Switch
BLK	18	969	Rear Washer Pump Ground	Front Ground	Front Ground
<b>Front Ground</b>					
BLK	14	969	Front Ground	All Front Ground Wires	
BLK	14	969	Front Ground	All Front Ground Wires	
<b>Left Marker Light</b>					
BLU	18	-	Marker B+	Headlight Switch	Headlight Switch
BLK	18	-	Ground	Front Ground	Front Ground
<b>Left Turn/Park*</b>					
GRY/BLK	16	926	Left Turn Signal	Turn Switch	Turn Switch
BLU	18	927	Left Park Light	Headlight Switch	Headlight Switch
BLK	18	969	Ground	Front Ground	Front Ground

COLOR	GA.	WIRE #	CONNECTS TO	WIRE STARTING POINT	SECTION OF STARTING POINT
<b>Left Head Lamp*</b>					
WHT	14	-	High Beam	Dimmer Switch	Dimmer Switch
WHT	14	-	High Beam	Right Head Lamp	Headlight Section
LT.GRN	14	-	Low Beam	Dimmer Switch	Dimmer Switch
LT.GRN	14	-	Low Beam	Right Head Lamp	Headlight Section
BLK	18	-	Ground	Front Ground	Front Ground
<b>Right Head Lamp*</b>					
WHT	14	-	High Beam	Left Head Lamp	Headlight Section
LT.GRN	14	-	Low Beam	Left Head Lamp	Headlight Section
BLK	18	-	Ground	Front Ground	Front Ground
<b>Right Marker*</b>					
WHT	18	-	Marker B+	Headlight Switch	Headlight Switch
BLK	18	-	Ground	Front Ground	Front Ground

**In the following Diagrams, only the wires with a circuit number are included in the Painless harness.**



**Diagram 9 GM 2 Wire Alternator**



**Diagram 10 Delco Alternator**

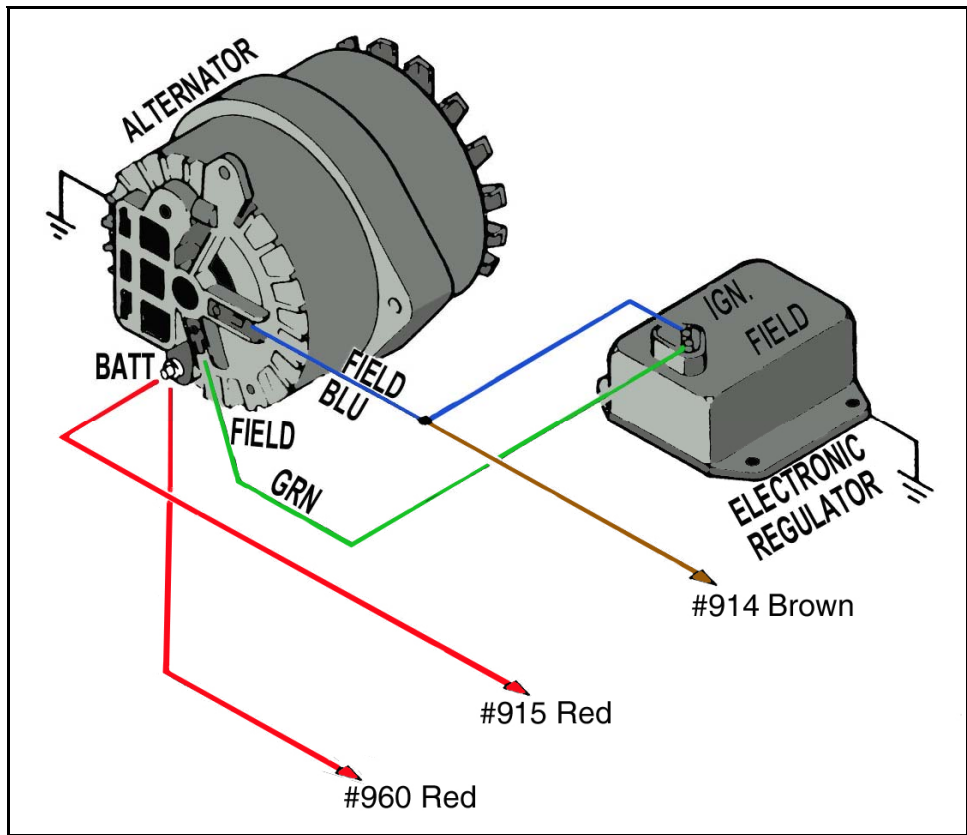


Diagram 11 Mopar Alternator

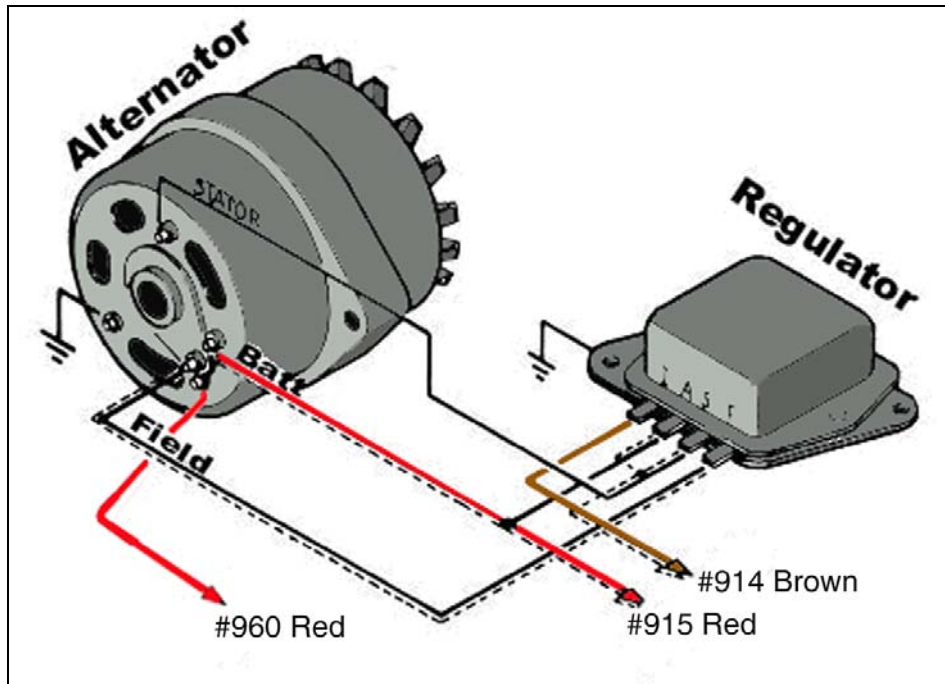
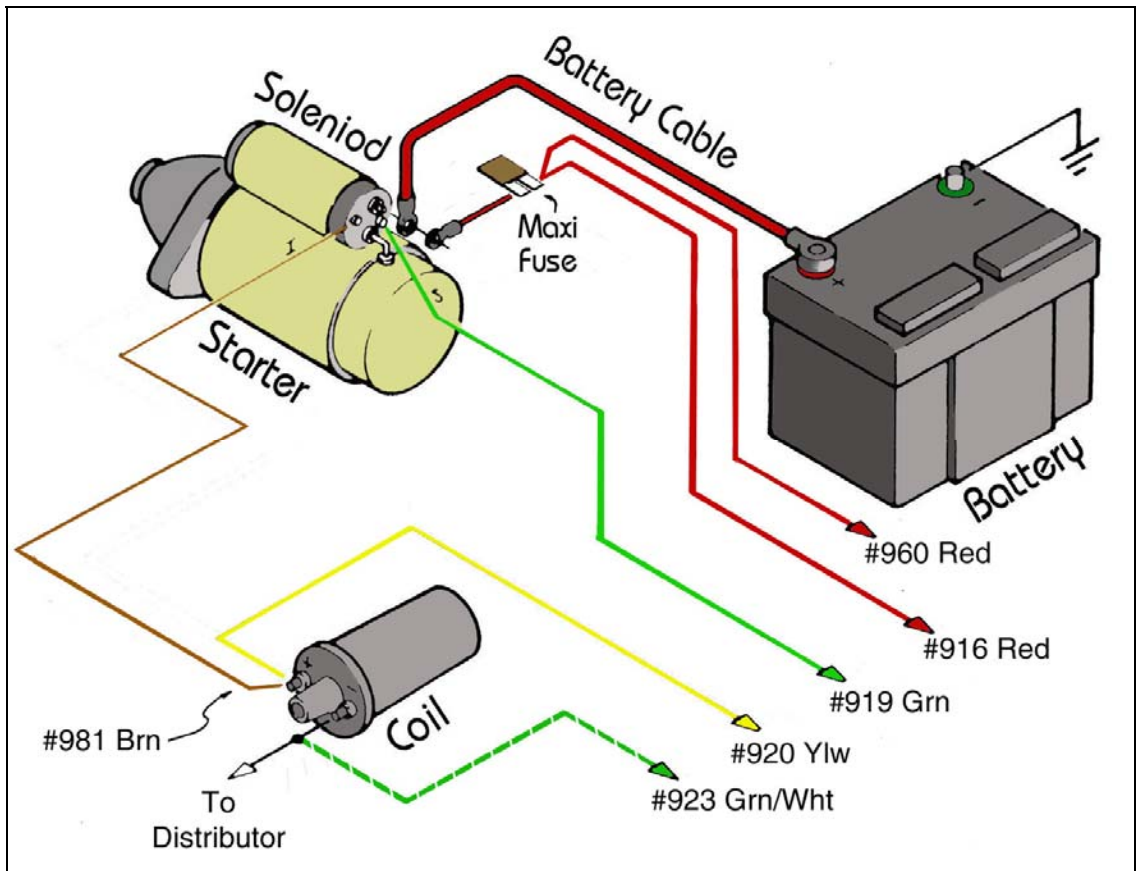
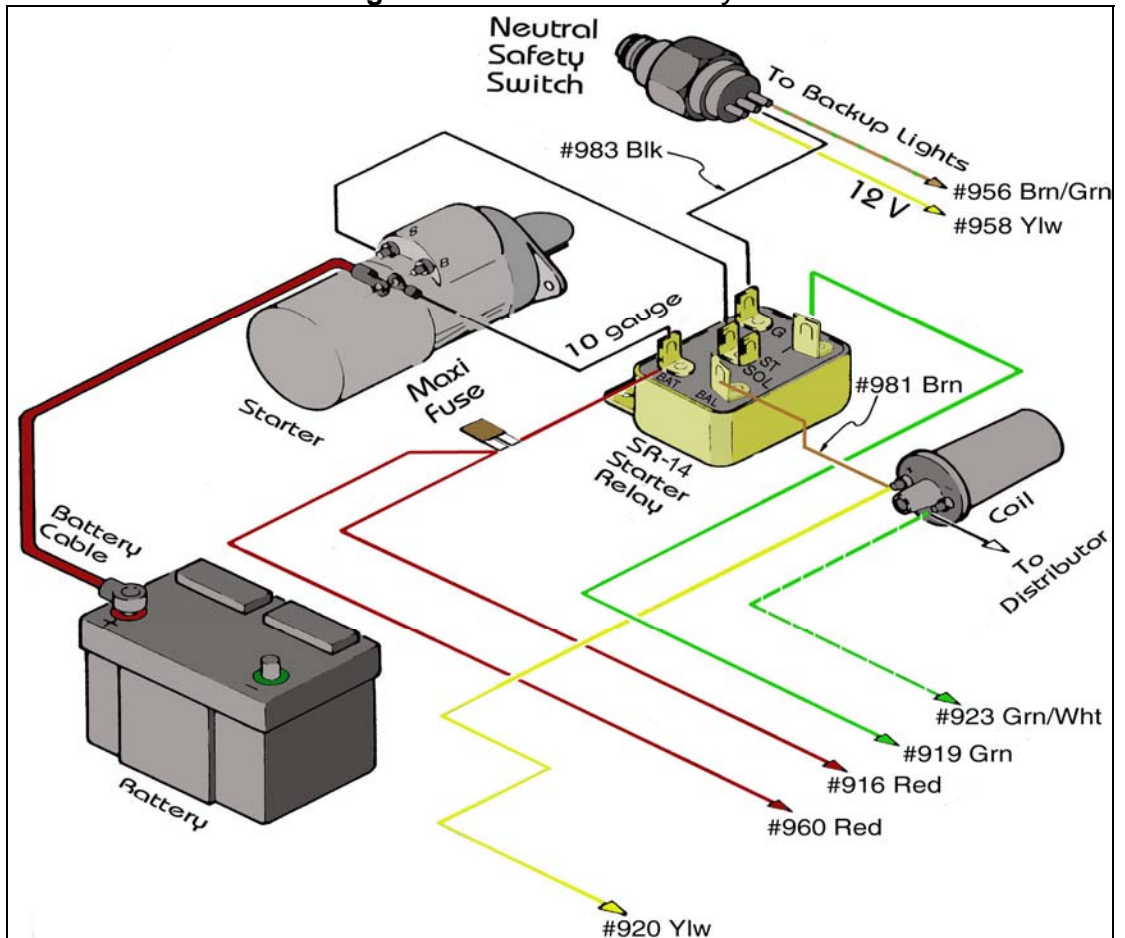


Diagram 12 Motorcraft Alternator



**Diagram 13 Delco Start/Run System**



**Diagram 14 Mopar Start/Run System**

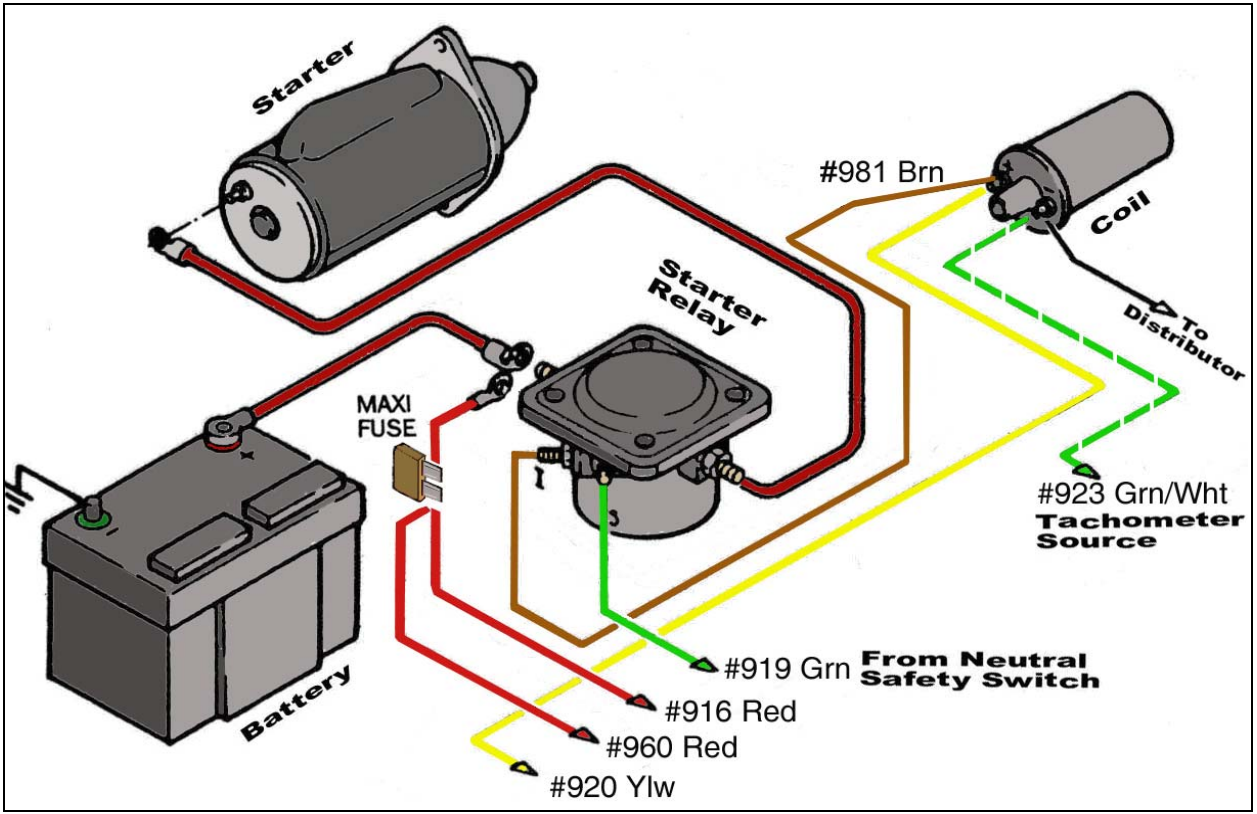


Diagram 15 Ford Start/Run System

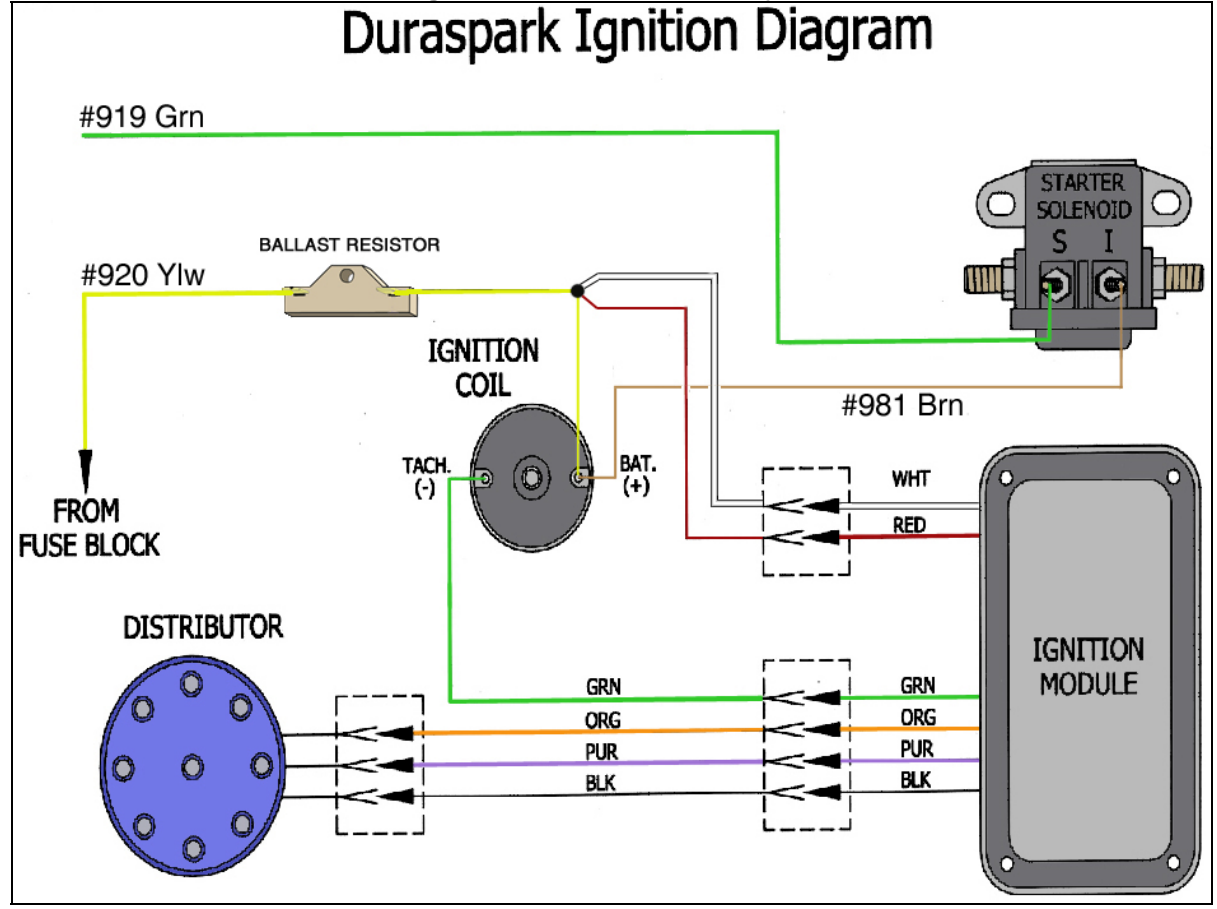
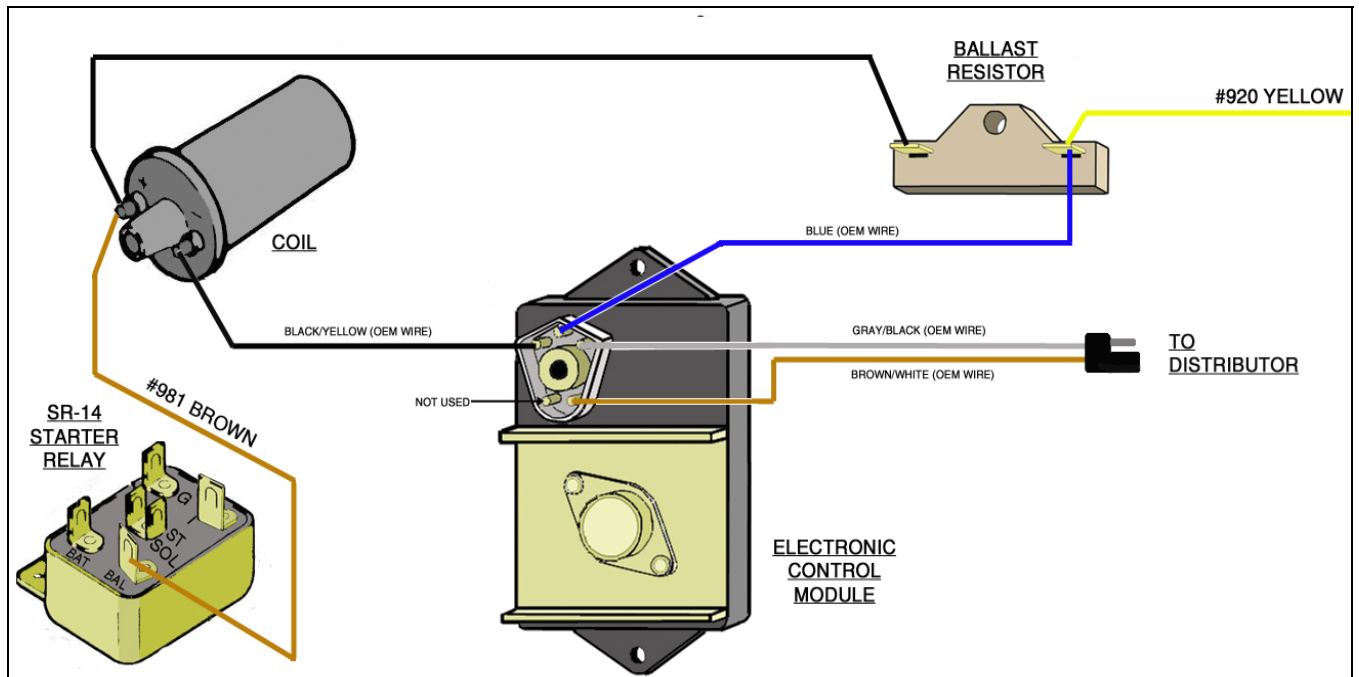


Diagram 16 Duraspark Ignition System



**Diagram 17 MOPAR Electronic Ignition System**

### **Painless Performance Limited Warranty and Return Policy**

Chassis harnesses, fuel injection harnesses, and Striker ColdShot units are covered under a lifetime warranty.

All other products manufactured and/or sold by Painless Performance are warranted to the original purchaser to be free from defects in material and workmanship under normal use. Painless Performance will repair or replace defective products without charge during the first 12 months from the purchase date. No products will be considered for warranty without a copy of the purchase receipt showing the sellers name, address and date of purchase. You must return the product to the dealer you purchased it from to initiate warranty procedures.



## NOTES

