

# JKS™

## Installation Instructions

Product: Adjustable Coil Over Spacer™

Part Number: PN 2210

### Welcome

CONGRATULATIONS on your purchase of a new JKS ACOS™ system! At JKS Manufacturing, we are committed to providing you with the best products available and your satisfaction is our first priority.

PLEASE READ these Installation Instructions carefully, and save them for future reference, as they contain important installation and maintenance information.

### Important

**MOST VEHICLES REQUIRE** additional parts or modifications to accommodate the immediate increase in ride height provided by the ACOS system.

**DO NOT EXCEED** maximum range of adjustment – see illustration on page 3.

**NOT COMPATIBLE** with Rancho coil springs.

### Tools Required

- Hydraulic Floor Jack and Jack Stands
- Metric/Standard Socket Wrench Set (including a 17mm socket)
- 6" Socket Extension
- 8mm and 1/4" Allen Wrenches
- Die Grinder with Cut-Off Wheel (or reciprocating saw)
- Grinding Wheel (or similar tool)
- File or Deburring Tool
- Emory Cloth (or similar paint stripping tool)
- 1/4" Drill Bit
- Rubber or Plastic Mallet \*
- Tape Measure
- Spray Lubricant (WD-40 or similar)
- Anti-Seize Lubricant
- Medium Strength Threadlocker
- Coil Spring Compressor \*
- Factory Service Manual (recommended)

\* Asterisk denotes tools that are not required for some applications. Thoroughly read instructions first to determine which tools will be required for your application.

### Parts

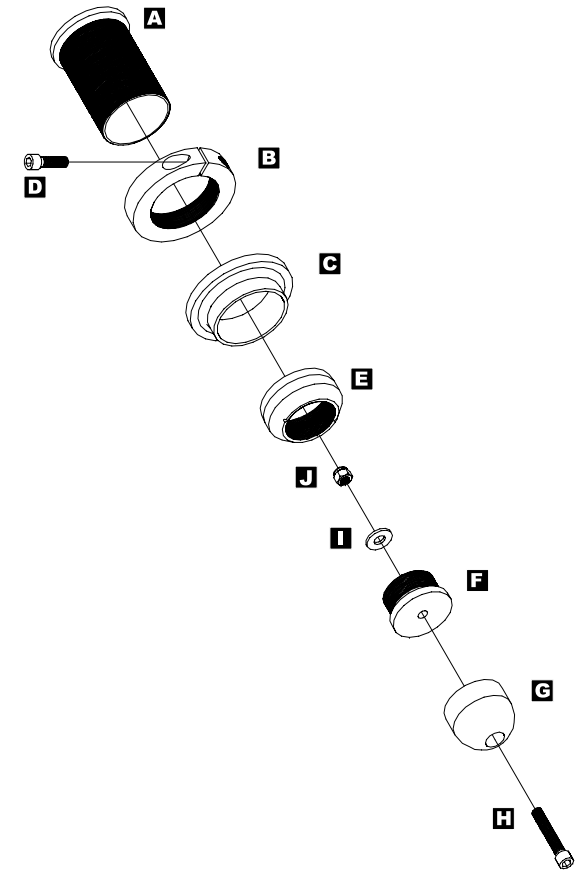

	DESCRIPTION	QTY
<b>A</b>	Threaded Tube	2
<b>B</b>	Adjuster Ring	2
<b>C</b>	Isolator Pad	2
<b>D</b>	5/16" x 1-1/4" Cap Bolt	2
<b>E</b>	Bump Stop Adapter	2
<b>F</b>	Bump Stop Plug	2
<b>G</b>	Polyurethane Bump Stop	2
<b>H</b>	10mm x 80mm Cap Bolt	2
<b>I</b>	10mm Flat Washer	2
<b>J</b>	10mm Locking Nut	2

## Installation

### 1. REMOVE FRONT COIL SPRINGS

- Remove the front coil springs per the factory service manual instructions for your vehicle.  
**HINT:** A coil spring compressor is useful for removal.

Depending on the application, it may be necessary to completely or partially remove any of the following components before spring can be free from upper mount.

- Shock Absorber
- Swaybar
- Brake Line
- ABS Wire

### 2. PREPARE SPRING RETAINER

The factory bump stop holder is welded to the upper spring retainer and must be permanently removed in order to install the ACOS™.

- Pry the rubber bump stop (jounce bumper) free from the bump stop holder.
- Remove the rubber isolator pad from the upper coil spring retainer.

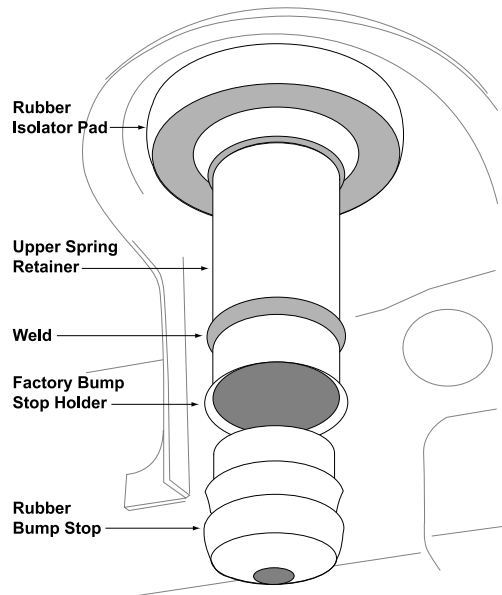

- Locate the factory weld that secures the bump stop holder to the upper coil spring retainer.

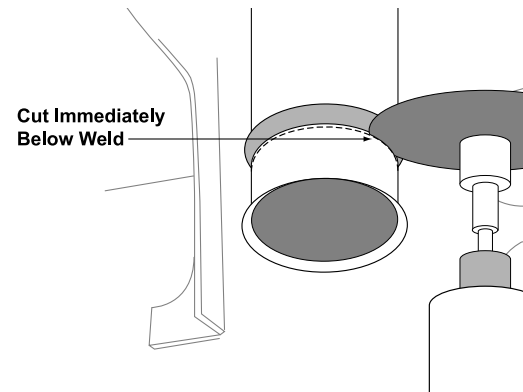

- Cut away the lower portion of the bump stop holder immediately below the weld. The weld itself must remain intact – use caution to avoid damaging it.  
**HINT:** A die grinder with cut-off wheel or reciprocating saw is useful for cutting away the bump stop holder.

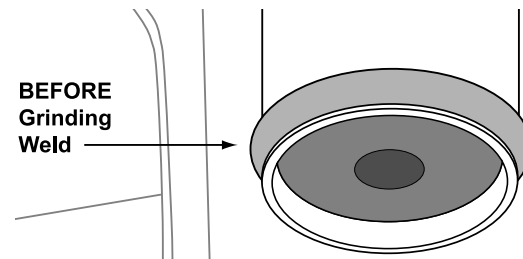

- Carefully grind the circumference of the weld to match the major diameter of the upper spring retainer. Remove only as much material as is necessary to avoid disturbing the weld integrity.  
**HINT:** A grinding wheel or similar tool is useful for grinding down weld material.

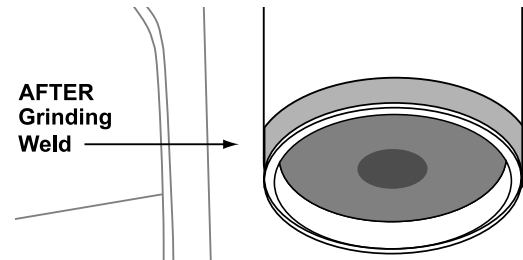

- Remove any sharp edges from the cut portion of the upper spring retainer.  
**HINT:** A file or deburring tool is useful for removing sharp edges.

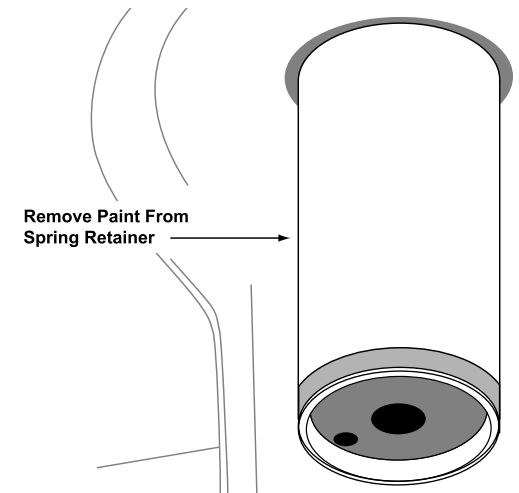

- Remove all of the factory paint from the surface of the upper spring retainer.  
**HINT:** Emory cloth or a suitable stripping tool is useful for paint removal.

To evacuate any water that collects inside of the upper spring retainer, it will be necessary to drill a new drainage hole in the bottom of the spring retainer. The original drainage hole located in the center of the spring retainer will be utilized as a mounting point for the supplied bump stop hardware. Therefore it will be necessary to drill the new drainage hole near the perimeter of the spring retainer.

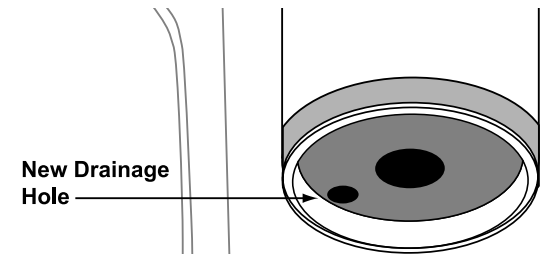

- Drill a 1/4" drainage hole in the bottom of the upper spring retainer as illustrated above.

### 3. INSTALL ACOS ON PREPARED SPRING RETAINER

- Apply a thin coating of anti-seize lubricant over the entire surface of the upper spring retainer in which the paint has been removed.
- Slide Threaded Tube (A) of ACOS over the lubricated spring retainer until the flange end rests against the upper spring mount.

**HINT:** If Threaded Tube will not slide all of the way onto the upper spring mount, temporarily install Bump Stop Adapter (E) on lower end of Threaded Tube and tap lightly with a mallet until flange end rests against the upper spring mount. A rubber or plastic mallet is strongly recommended to prevent damage to threads.

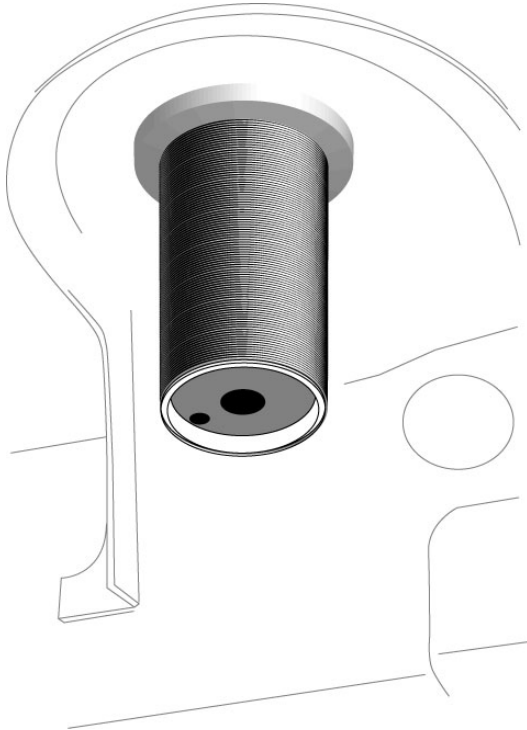

### 4. SET ADJUSTER RING FOR DESIRED RIDE HEIGHT

- Apply spray lubricant to threads of Threaded Tube (A).
- Install Adjuster Ring (B) by threading it onto the Threaded Tube (A).
- Slide Isolator Pad (C) onto Threaded Tube (A) until flush with Adjuster Ring (B).

**IMPORTANT:** Vehicle ride height is determined by measuring the distance between the bottom of upper spring mount and bottom of Isolator Pad, and then subtracting 1/2" (0.50 in.).

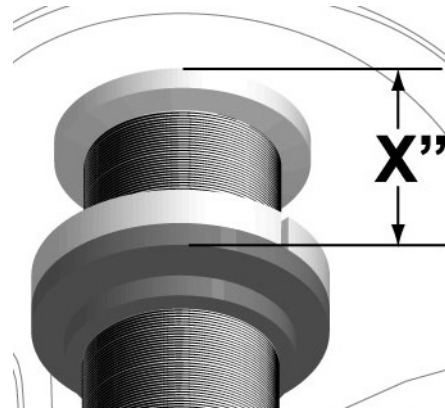

$$X'' - 1/2'' = \text{RIDE HEIGHT}^*$$

\* Represents increase in ride height over OE suspension



#### **WARNING**

**DO NOT EXCEED  
MAXIMUM RANGE OF ADJUSTMENT**

**ADJUSTMENT RANGE \***

**MINIMUM: 1" (1.0 in.)**

**MAXIMUM: 2-1/2" (2.5 in.)**

- Rotate Adjuster Ring (B) to desired position and tighten the recessed 5/16" x 1-1/4" Cap Bolt (D) to lock in place.

### 5. INSTALL BUMP STOP ON THREADED TUBE OF ACOS

- Apply a drop of medium strength thread locking compound to bottom few threads of Threaded Tube (A).

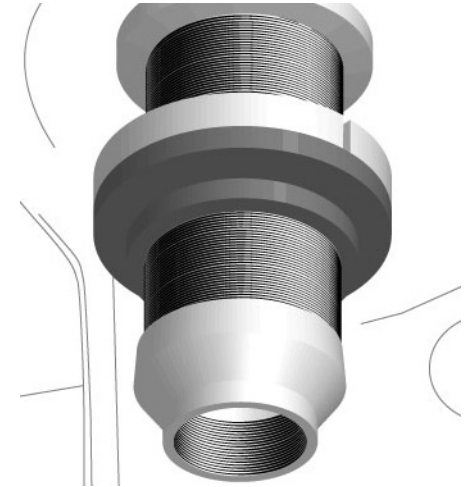

- Install Bump Stop Adapter (E) onto Threaded Tube (A) and tighten by hand until snug.

**IMPORTANT:** If flange end of Threaded Tube (A) begins to pull away from the upper spring mount before the Bump Stop Adapter (E) is completely installed, turn the Bump Stop Adapter counter-clockwise one full turn and reseat Threaded Tube against upper spring mount.

- Apply anti-seize lubricant to threads of Bump Stop Plug (F).
- Install Bump Stop Plug (F) by threading it completely into the Bump Stop Adapter (E).

- Insert the 10mm x 80mm Cap Bolt (H) into the recessed hole in Polyurethane Bump Stop (G) and through the hole in the bottom of the Bump Stop Plug (F).



- Secure the Polyurethane Bump Stop (G) to the Bump Stop Plug (F) by installing the 10mm Flat Washer (I) and 10mm Locking Nut (J) from above the upper spring mount.  
**HINT:** To install the 10mm Flat Washer and 10mm Locking Nut, tape them onto a 17mm socket attached to a 6" long socket extension and lower into the access hole located above the upper spring mount.
- Slowly tighten 10mm x 80mm Cap Bolt (H) until the sides of the Polyurethane Bump Stop (G) begin to bulge. **Do NOT overtighten!**

## 6. RE-INSTALL FRONT COIL SPRINGS

- Re-install the front coil springs per the factory service manual instructions for your vehicle.  
**HINT:** A coil spring compressor is useful for installation.
- Also re-install any of the components that were removed during the REMOVE FRONT COIL SPRINGS section of this installation.



### **ATTENTION INSTALLER**

#### IMPORTANT NOTE REGARDING SHOCK ABSORBERS

**To prevent the coil springs from becoming unseated during maximum suspension extension, correct length shock absorbers must be installed.**

## Operation

### Ride Height Adjustments

Future ride height adjustments should be made with **NO LOAD** on the front coil springs, and the suspension at **FULL DROOP**.

**NEVER TURN** Adjuster Ring (B) while under tension and **ALWAYS APPLY SPRAY LUBRICANT** to Threaded Tube (A) before adjusting.

## Maintenance

Regular cleaning with pressurized water is recommended to maximize ease of operation and reliability.

In addition, the Bump Stop Adapter (E) has two 1/8" drainage holes that evacuate any water collected inside the upper spring retainer. Periodically check for blockages and clear the drainage holes if necessary.

© 2007 JKS Manufacturing, Inc & Aftermarketing, LLC  
Revision Date 5/8/2008