





Installation Instructions







HighRock 4x4™ Slider Step

Vehicle Application:

- Jeep JK Wrangler Unlimited
2007 – Current
Part Number: 49314

www.Bestop.com - We're here to help! Visit our web site and click on "[Ask a Question](#)". Click here for more [Jeep® Accessories by Bestop](#).

INSTALLATION TIME	SKILL LEVEL
 1 Hour	 2 - Moderately Easy

TOOLS			
 Power Drill 5/16" Bit	 Ratchet	 Socket 10mm	 Wrench 10mm
 Allen Wrench 5mm and 6mm	 Safety Glasses		



DO NOT INSTALL THIS PRODUCT ON ANY VEHICLE OTHER THAN THOSE LISTED ABOVE. This product is only designed for the vehicles listed above. Failure to install this product on the proper vehicle could cause injury to the vehicle occupants and damage to the product.

⚠ WARNING This product is designed primarily to enhance the appearance of the vehicle and to shield the occupants from ordinary weather conditions. Do not rely in any way on the components of this product to contain occupants within the vehicle, or to protect against injury or death in the event of an accident. This product will not protect the occupants from falling objects. Never operate the vehicle in excess of manufacturer's specifications.

WEAR SEAT BELTS AT ALL TIMES

Read and follow, precisely, all installation instructions provided when installing product. Failure to do so may result in a poor fit and could place occupants of the vehicle in a potentially dangerous situation.

HighRock 4x4™ Slider Step Installation Instructions

Parts List and Hardware Identification

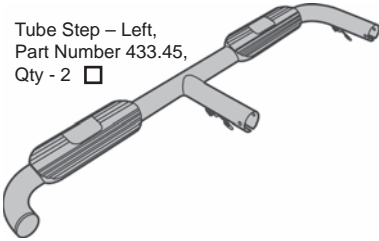

Tube Step – Left,
Part Number 433.45,
Qty - 2

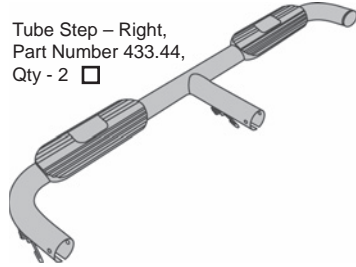

Tube Step – Right,
Part Number 433.44,
Qty - 2

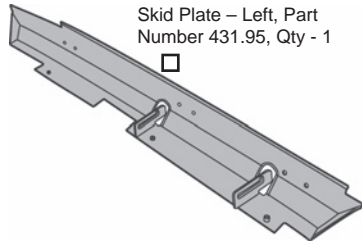

Skid Plate – Left, Part
Number 431.95, Qty - 1

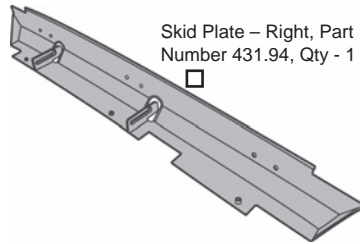

Skid Plate – Right, Part
Number 431.94, Qty - 1

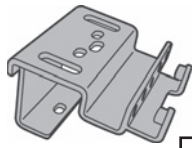

Short Bracket, Part Number
431.90, Qty - 4

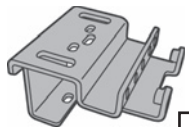

Long Bracket, Part Number
431.91, Qty - 2

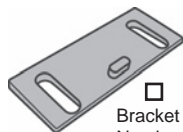

Bracket Spacer, Part
Number 440.64, Qty - 2

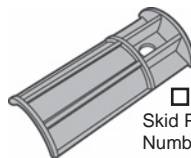

Skid Plate Glide, Part
Number 435.28, Qty - 8

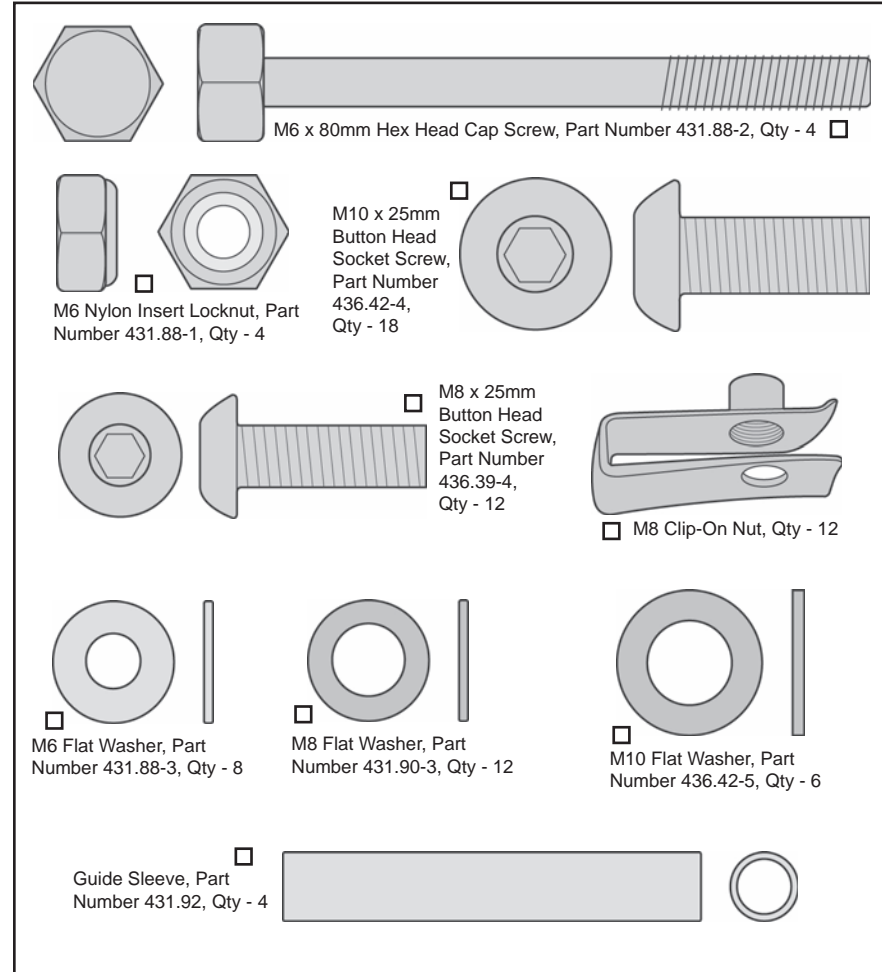

M6 x 80mm Hex Head Cap Screw, Part Number 431.88-2, Qty - 4

M6 Nylon Insert Locknut, Part
Number 431.88-1, Qty - 4

M10 x 25mm
Button Head
Socket Screw,
Part Number
436.42-4,
Qty - 18

M8 x 25mm
Button Head
Socket Screw,
Part Number
436.39-4,
Qty - 12

M8 Clip-On Nut, Qty - 12

M6 Flat Washer, Part
Number 431.88-3, Qty - 8

M8 Flat Washer, Part
Number 431.90-3, Qty - 12

M10 Flat Washer, Part
Number 436.42-5, Qty - 6

Guide Sleeve, Part
Number 431.92, Qty - 4

HighRock 4x4™ Slider Step Installation Instructions

1 Orient Tube Step to Skid Plate

Place Tube Step into Skid Plate to check orientation.

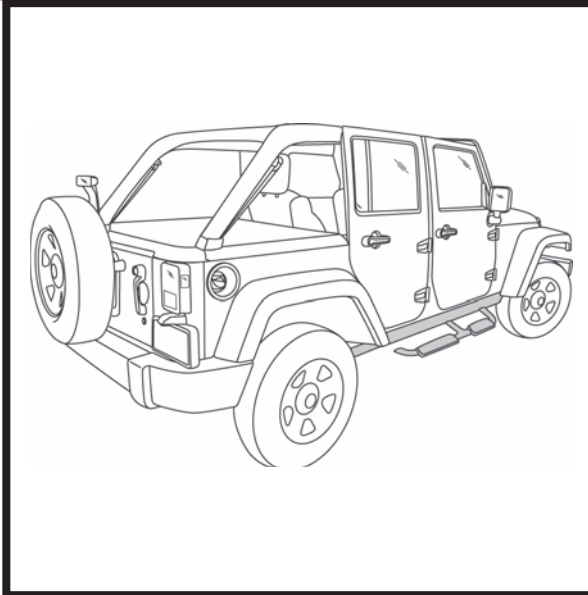
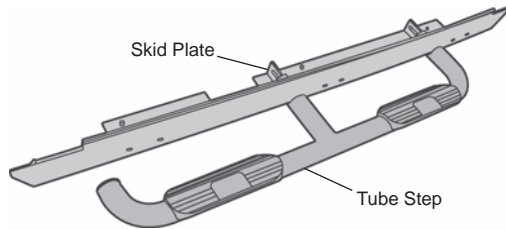

3 Install Skid Plate Glides

Slide two (2) Skid Plate Glides into each end of Step Tube.

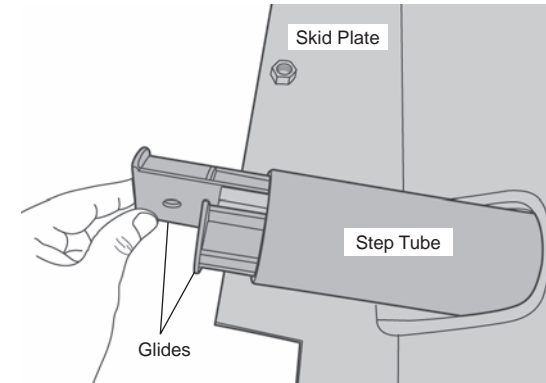

2 Assemble Tube Step to Skid Plate

Hook Bungee Cord on Tube Step onto Skid Plate and pull down onto Step Tube until Step Tube Slides into Skid Plate.

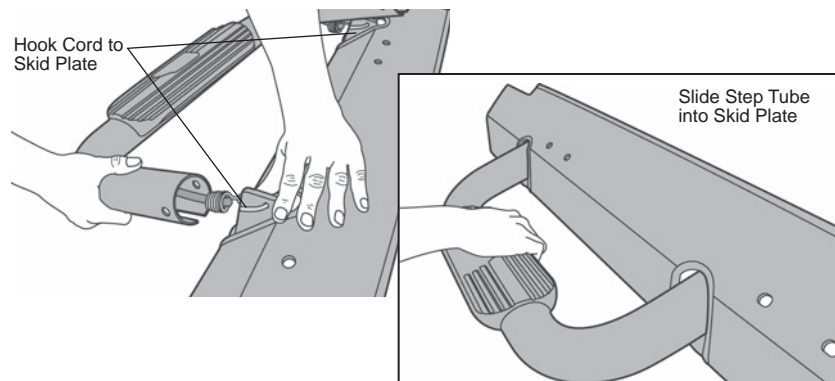

4 Secure Step Tubes to Skid Plate

Slide Guide Sleeve through Step Tube and Skid Plate Glides and secure with M6 x 80mm Hex Head Cap Screw, two (2) M6 Washers and an M6 Nylon Insert Locknut. Repeat on both ends of the Step Tube.

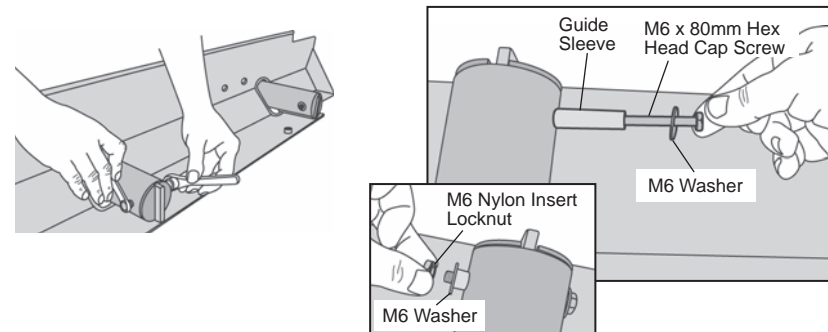

HighRock 4x4™ Slider Step Installation Instructions

5 Preassemble Remaining Slider Step

Repeat Steps 1 – 4 with the remaining Slider Step.

6 Drill Following Hole

Use a 5/16" drill bit to open up the following holes at the front and center of the vehicle.

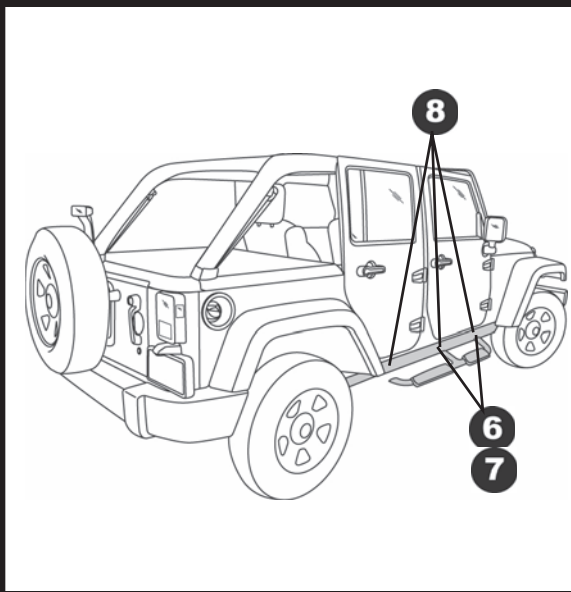
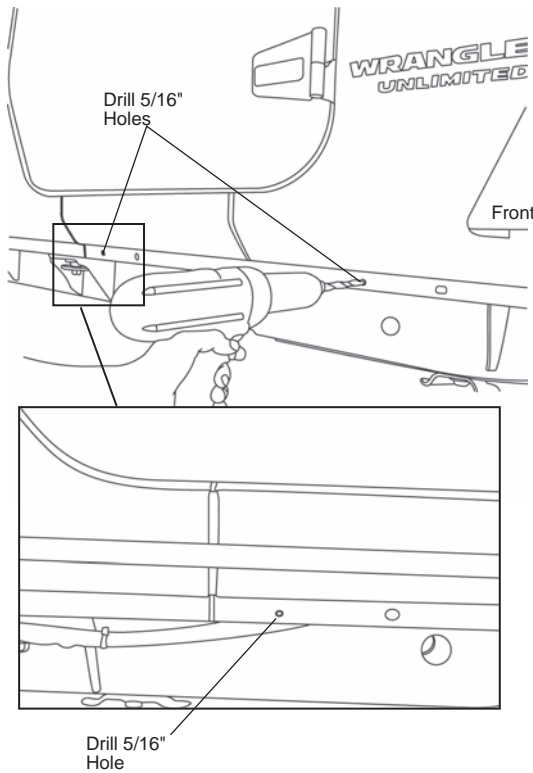

7 Remove Putty

Remove putty from underneath vehicle.

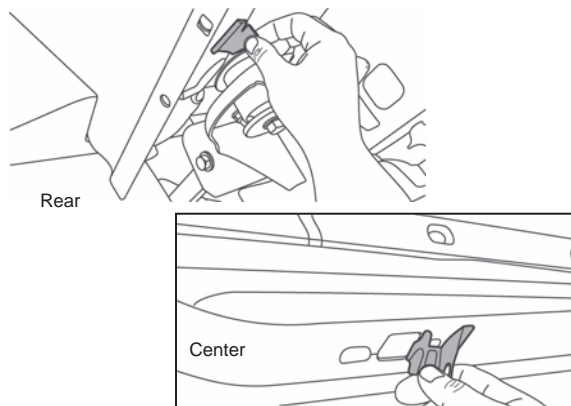

8 Install Clip-On Nuts

Slide a Clip-On Nut onto these locations.

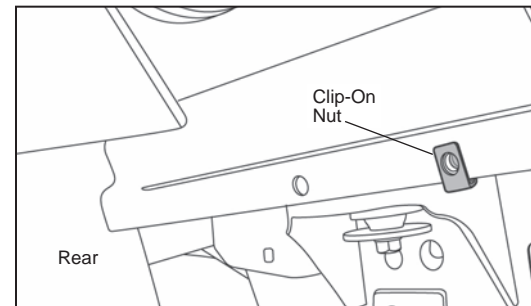
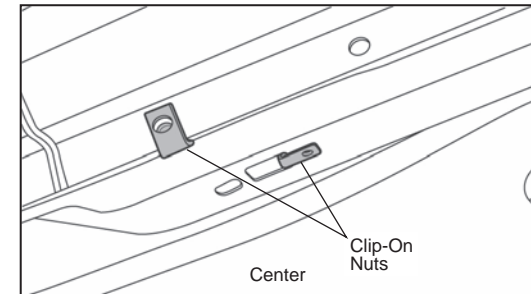
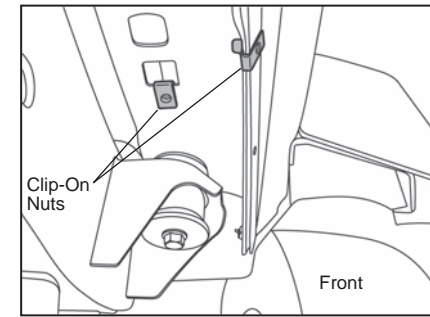

HighRock 4x4™ Slider Step Installation Instructions

9 Install Front Short Bracket

Use an M8 x 25mm Button Head Socket Screw and M8 Flat Washer to mount a Short Bracket to the Clip-On Nuts at the front of the vehicle as shown.

M8 x 25mm Button Head Socket Screw and M8 Flat Washer

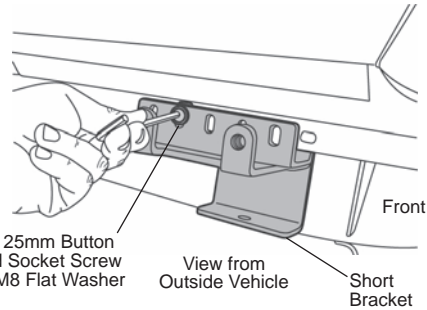
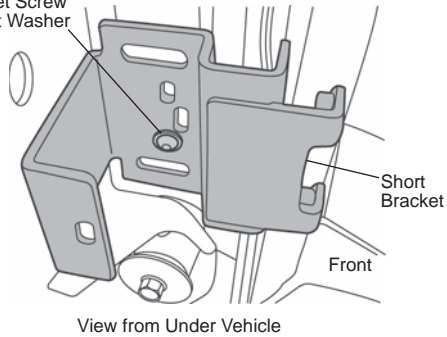

M8 x 25mm Button Head Socket Screw and M8 Flat Washer

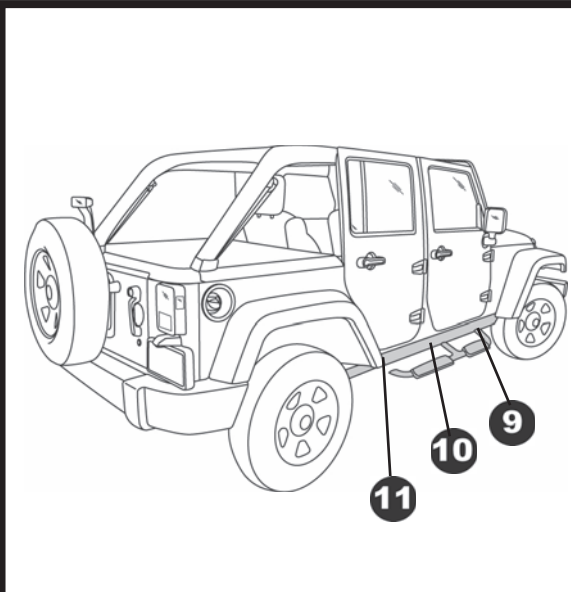
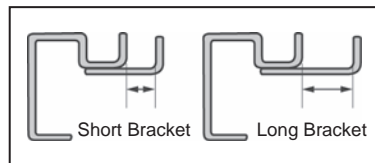

10 Install Center Long Bracket

Use an M8 x 25mm Button Head Socket Screw and M8 Flat Washer to mount a Long Bracket to the Clip-On Nuts at the center of the vehicle as shown.

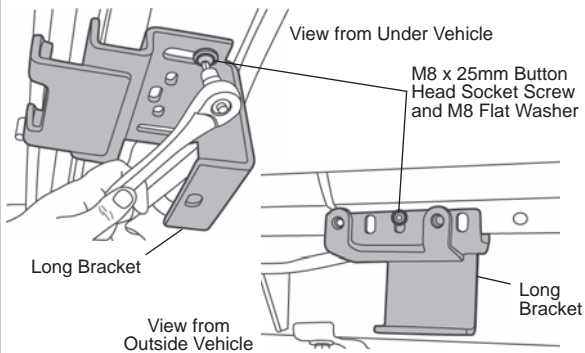

11 Install Rear Short Bracket

Place a Bracket Spacer on top of a Short Bracket. Use an M8 x 25mm Button Head Socket Screw and M8 Flat Washer to mount the Bracket and Spacer to the Clip-On Nut and the existing tapped hole at the rear of the vehicle as shown.

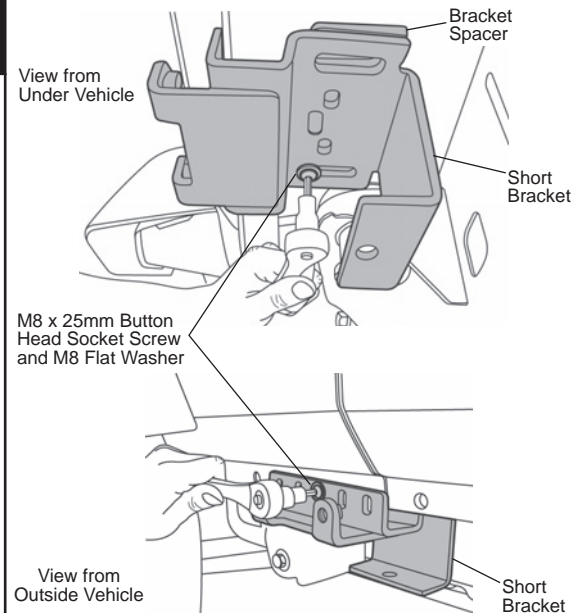
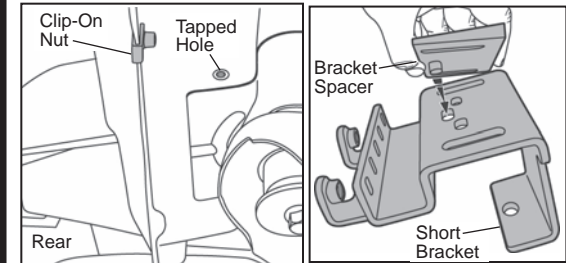

HighRock 4x4™ Slider Step Installation Instructions

12 Install Step Tube Assembly

Use M10 x 25mm Button Head Socket Screws and M10 Flat Washers to mount the underneath of Tube Step Assembly to the Brackets. Do not tighten. Adjustment may be necessary in the next step.

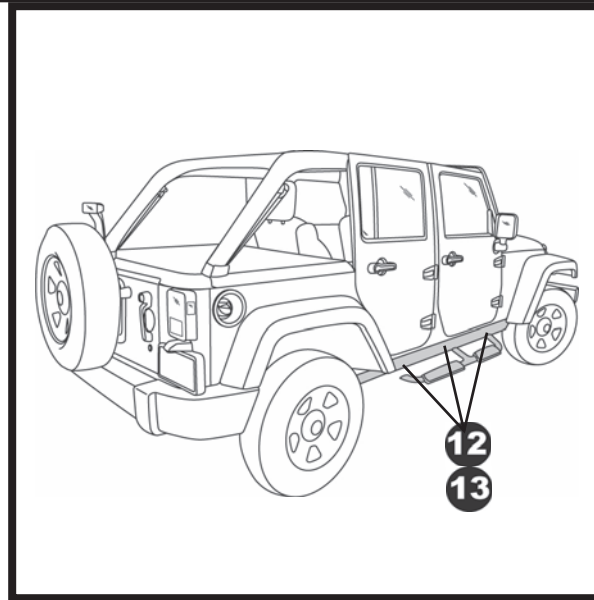
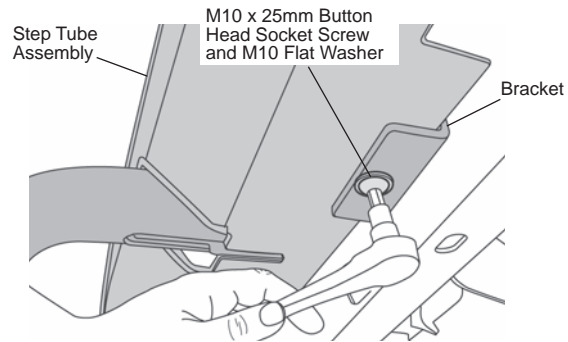

13 Secure Step Tube Assembly

Use M10 x 25mm Button Head Socket Screws to mount the front face of Tube Step Assembly to the Brackets. Do not tighten the bolts until all four (4) bolts have been started.

Once all bolts have been started, tighten all bolts.

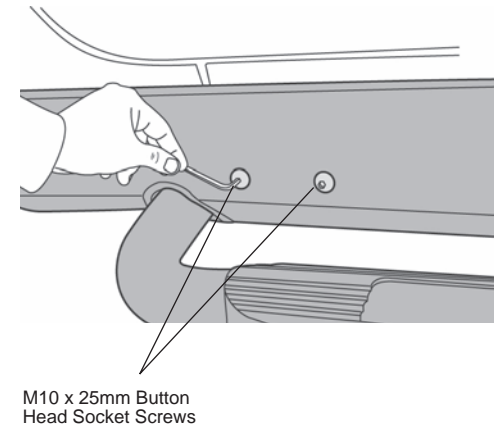

HighRock 4x4™ Slider Step Installation Instructions

LIMITED WARRANTY

We warrant our product to be free from defects in material and workmanship, for the terms specified below, provided there has been normal use and proper maintenance. This warranty applies to the original purchaser only. All remedies under this warranty are limited to the repair or replacement of any item or items found by the factory to be defective within the time period specified. If you have a warranty claim, first you must call our factory at the number below for instructions. You must retain proof of purchase and submit a copy with any items returned for warranty work. Upon completion of warranty work, if any, we will return the repaired or replaced item or items to you freight prepaid. Damage to our products caused by accidents, fire, vandalism, negligence, misinstallation, misuse, Acts of God, or by defective parts not manufactured by us, is not covered under this warranty.

THE WARRANTY TIME PERIOD IS AS FOLLOWS FOR REPLACE-A-TOP™, SAILCLOTH REPLACE-A-TOP™, SUPERTOP®, SUPERTOP® REPLACEMENT SKINS, SUNRIDER®, AND TIGERTOP®: TWO YEARS FROM DATE OF PURCHASE.

THE WARRANTY TIME PERIOD IS AS FOLLOWS FOR ALL OTHER “SOFT GOODS” MANUFACTURED BY OUR COMPANY (USING PRIMARILY VINYL, PLASTICS, AND/OR FOAM): ONE YEAR FROM DATE OF PURCHASE.

THE WARRANTY TIME PERIOD IS AS FOLLOWS FOR ALL OTHER “HARD GOODS” MANUFACTURED BY OUR COMPANY (USING PRIMARILY METALS, PLASTICS, AND/OR FIBERGLASS): ONE YEAR FROM DATE OF PURCHASE.

ANY IMPLIED WARRANTIES OF MERCHANTABILITY AND/OR FITNESS FOR A PARTICULAR PURPOSE CREATED HEREBY ARE LIMITED IN DURATION TO THE SAME DURATION AND SCOPE AS THE EXPRESS WRITTEN WARRANTY. OUR COMPANY SHALL NOT BE LIABLE FOR ANY INCIDENTAL OR CONSEQUENTIAL DAMAGE.

Some states do not allow limitations on how long an implied warranty lasts, or the exclusion or limitation of incidental or consequential damages, so the above limitations or exclusions may not apply to you. This warranty gives you specific legal rights, and you may also have other rights which vary from state to state.



For further information or request for warranty work, please contact:

Bestop Inc., Customer Service

Toll-Free: (800)845-3567

Main: (303)465-1755

E-mail: csbestop@Bestop.com

Website: www.Bestop.com