

INSTALLATION INSTRUCTIONS

2007-12 JEEP WRANGLER

PART# 1050 / 1050-2

PARTS LIST:

| Qty | Description | Qty | Description |
|-----|--|-----|-------------------------------|
| 1 | Aries Grill guard | 10 | 12mm Lock washers |
| 1 | Driver/left mounting bracket | 10 | 12mm Hex nuts |
| 1 | Passenger/right mounting bracket | 2 | 10mm x 30mm Button Head Bolts |
| 1 | Driver/Left upper brace bracket | 6 | 10mm Flat washers |
| 1 | Passenger/right upper brace bracket | 3 | 10mm Lock washers |
| 2 | 8mm x 30mm Rod bolts 2007-12 | 3 | 10mm Hex nuts |
| 1 | 10mm x 50mm Rod bolt 2012 Driver side only | 4 | 8mm Flat washers |
| 10 | 12mm x 30mm Hex bolts | 2 | 8mm Lock washers |
| 20 | 12mm Flat washers | 2 | 8mm Hex nut |

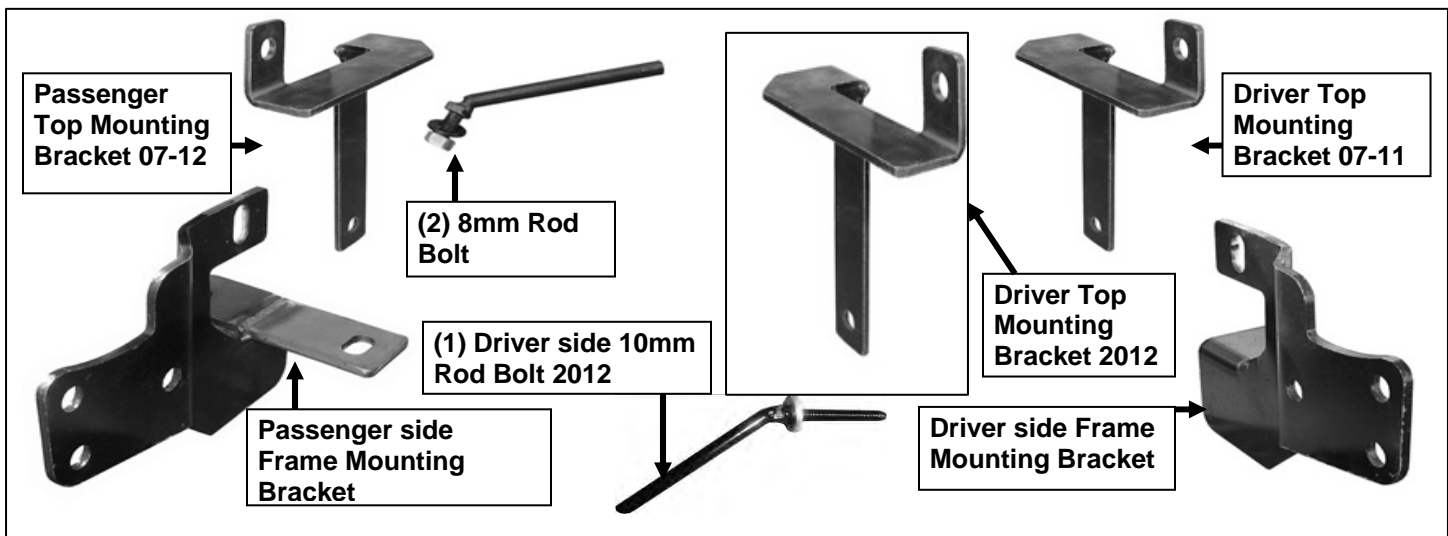

PROCEDURE:

1. REMOVE CONTENTS FROM BOX. VERIFY ALL PARTS ARE PRESENT. READ INSTRUCTIONS CAREFULLY BEFORE STARTING INSTALLATION. CUTTING IS REQUIRED. ASSISTANCE IS RECOMMENDED.
2. Start by removing front plastic splash shield from under the vehicle, using a flat tip screwdriver pry and remove the plastic push pins holding the shield, as seen in (Fig 1 & 1A)
3. Once removed start to remove the top plastic fill plate between the bumper and the front grill there are 2 push pins securing the plastic cover to the top of each frame rail, as seen in (Fig 2) with the plastic push pins removed, remove the fill plate and place it & the splash shield on a clean, stable work surface for trimming later.
4. Select the passenger/right side mounting bracket from the list of parts above, and secure it to the bottom of the cross member with (1) 12mm x 30mm hex bolt, (2) 12mm flat washers, (1) 12mm lock washer and (1) 12mm hex nut. **NOTE: 07-09 models will use the outer mounting hole location, seen in (Fig 3), 2010-12 models will use the inner mounting hole location, seen in (Fig 3B).** Secure the top of the bracket with (1) 12mm x 30mm hex bolt, (2) 12mm flat washers, (1) 12mm lock washer and (1) 12mm hex nut through the upper tab on the side of the mounting

bracket as seen in **(Fig 4)** Snug but do not tighten hardware at this time. Repeat step 4 to install the driver/left side mounting bracket. **NOTE: Driver side 2012 models do not install the upper hardware at this time.**

5. Next, place the top fill plate back in position pending on the year of the vehicle & from the bottom mark a slot on the underside of the fill plate straight up from the frame upright seen in **(Fig 5)** 2007-2011 top brace brackets mount to the side of the frame upright seen in **Fig 5A)** **NOTE: 2012 driver side is attached between the frame upright & rail due to the air pump as seen in Fig 6).**once marked out Cut the 2 slots to clear the top brackets. **NOTE:** Only cut a slot long enough to clear the top brace brackets. **IMPORTANT!** Do not cut completely through either end of the fill panel. Once slots have been cut reinstall the fill panel with the factory push pins.
6. With the fill plate reinstalled begin to install the upper brace brackets **NOTE: 07-12 models Passenger side / 07-11 Driver side** Select (1) 8mm x rod bolt and (1) 8mm flat washer. From the driver/left side, insert the rod bolt and flat washer into the opening at the base of the frame as seen in **(Fig 8)** and out the factory hole on the side of the frame above the tab on the previously installed frame mounting bracket, seen in **(Fig 5A)**. Hold the rod bolt in place and insert the driver/left side top brace bracket through the slots cut in the fill panel. Secure the top brace bracket to the side of the frame with the included (1) 8mm flat washer, (1) 8mm lock washer, and (1) 8mm hex nut, seen in **(Fig 5A)**. Snug but do not tighten hardware at this time. Repeat this step for the passenger/right side top brace bracket installation.
7. **NOTE: 2012 models driver side** Select the brace bracket and the 10mm x 50mm rod bolt and (1) 10mm flat washer, from the driver/left side, insert the brace bracket through the fill plate and in between the air pump and the upright frame as seen in **(Fig 6)** then place the rod bolt and flat washer into the opening at the front base of the cross frame as seen in **(Fig 9)**. through the brace bracket and out the factory hole and through the lower mount bracket on the side of the frame rail, hold the rod bolt in place and Secure the top brace bracket and the mount bracket to the side of the frame with the included (1) 10mm washer and (1) 10mm lock washer, (1) 10mm hex nut, seen in **(Fig 10)**. Snug but do not tighten hardware at this time.
8. With assistance, lift the Grille Guard up to the inside of the lower mounting brackets; line up the holes in the mounting brackets with the holes in the Grille Guard. Secure to the mount brackets with (3) 12mm x 30mm hex bolts, (6) 12mm flat washers, (3)12mm lock washers and (3) hex nuts per side, as seen in **(Fig11)**. Snug but do not tighten hardware at this time, adjust the grille guard back into an upright position and secure the Top Brackets to the grille guard with the included (2) 10mm x 30mm button head bolts, (4) 10mm flat washers and (2) 10mm lock washers and (2) 10mm hex nuts. Adjust the grill guard & brackets as necessary to center & level the bar. Once properly aligned, tighten all of the hardware.
9. Next hold the splash shield up & into position, mark the cut area on the inside of the shield, Start by trimming a small opening and slowly enlarge the opening to get the best fit around the brackets. Once done reinstall splash shield with the factory push pins.
10. Do periodic inspections of the installation to make sure that all hardware is secure and tight. **To protect your investment**, wax this product after installing. Regular waxing is recommended to add a protective layer over the finish. Do not use any type of polish or wax that may contain abrasives that could damage the finish.
For stainless steel: Aluminum polish may be used to polish small scratches and scuffs on the finish. Mild soap may be used also to clean the products.
For gloss black finishes: Mild soap may be used to clean the products.

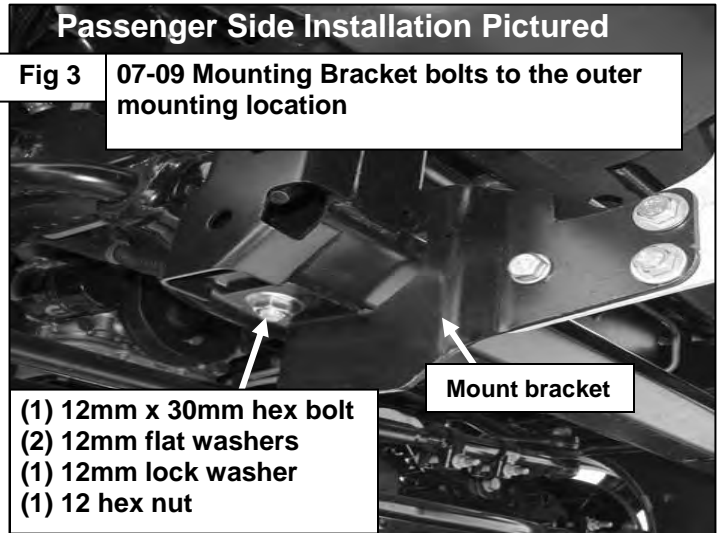
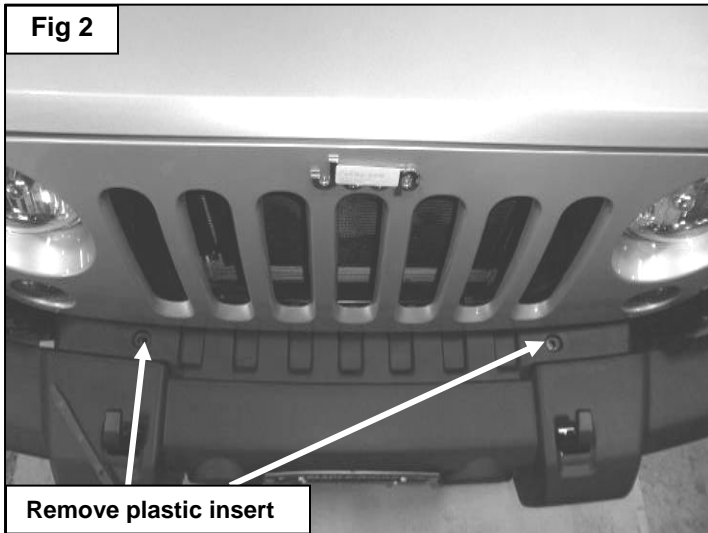
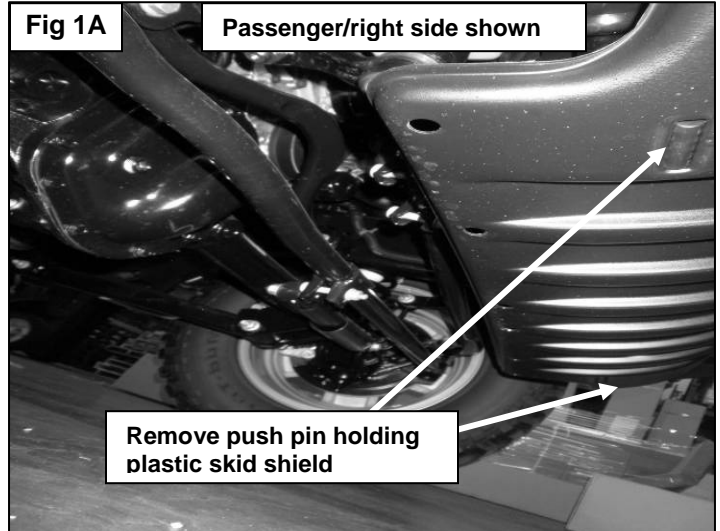
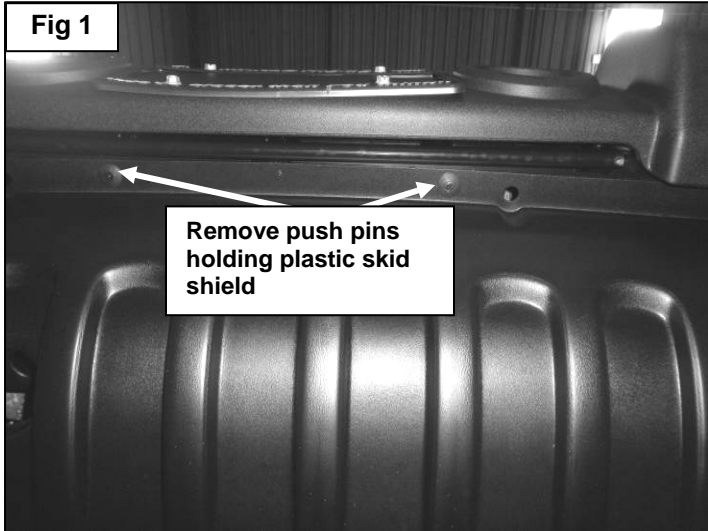

Passenger Side Installation Pictured

Driver Side Installation Pictured

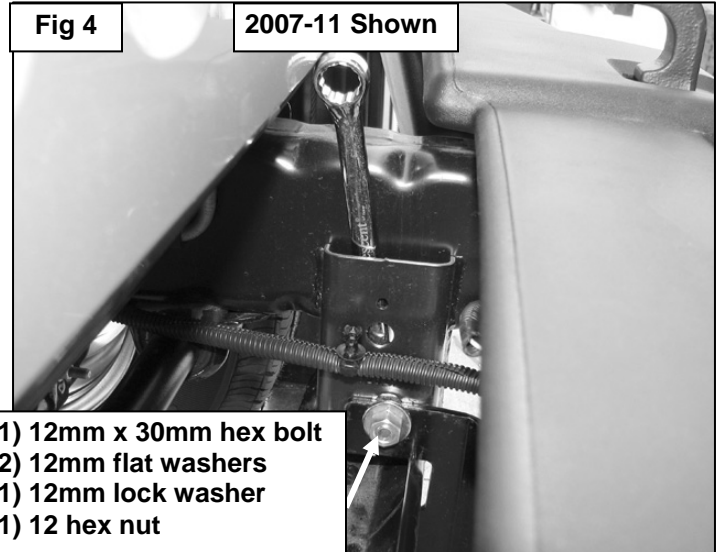
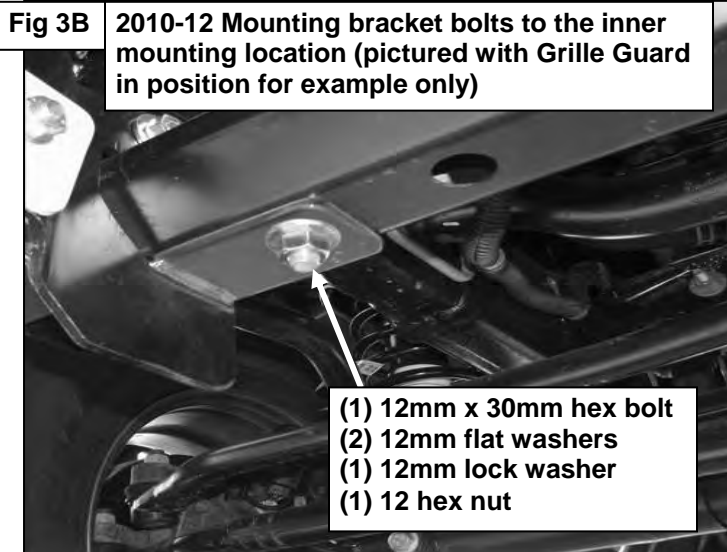
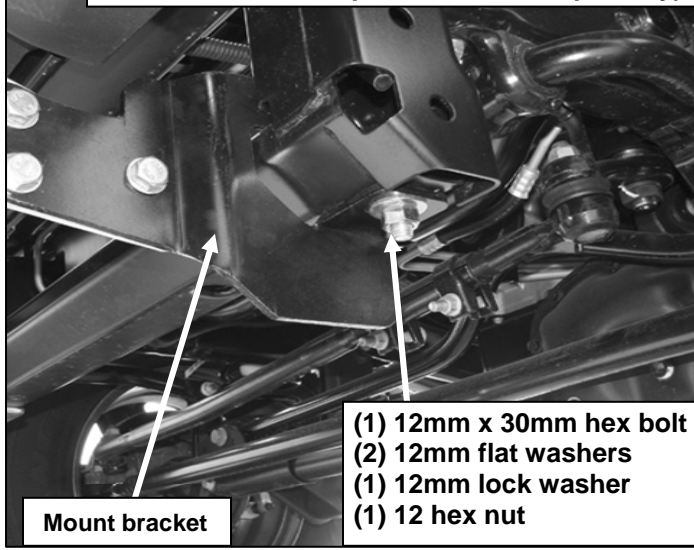
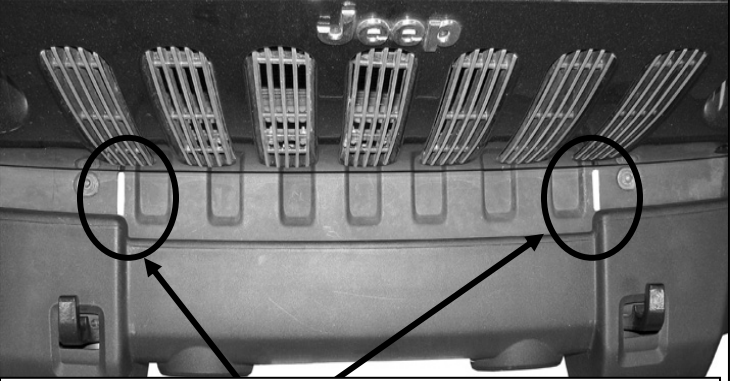

Fig 4B Driver side frame mounting bracket (pictured with Grille Guard in position for example only)



- (1) 12mm x 30mm hex bolt
- (2) 12mm flat washers
- (1) 12mm lock washer
- (1) 12 hex nut

Fig 5



Reinstall the fill panel and mark the cut area on the inside of the fill panel straight up from the frame upright. Start with a small opening and slowly enlarge the opening to get the best fit around the brackets. Area cut from fill panel pictured for example only.

(Fig 5A & 6) Pictured without fill plate for example only

Fig 5A 2007-11 Driver side Shown

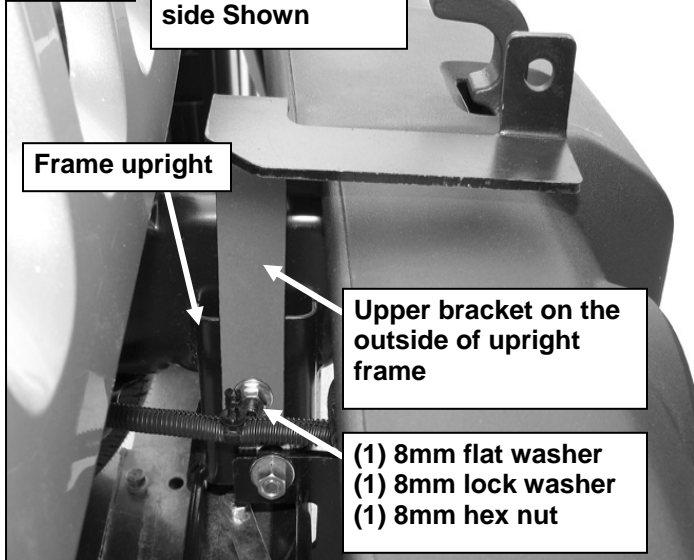

- (1) 8mm flat washer
- (1) 8mm lock washer
- (1) 8mm hex nut

Fig 6 2012 Driver side Shown

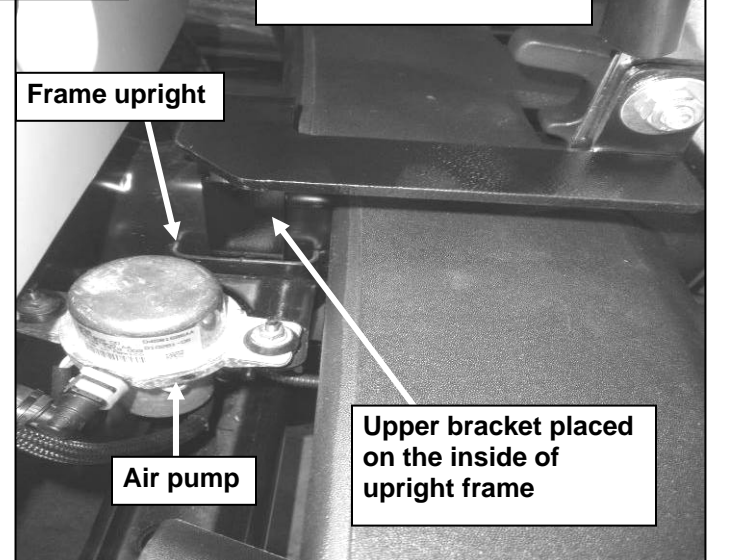
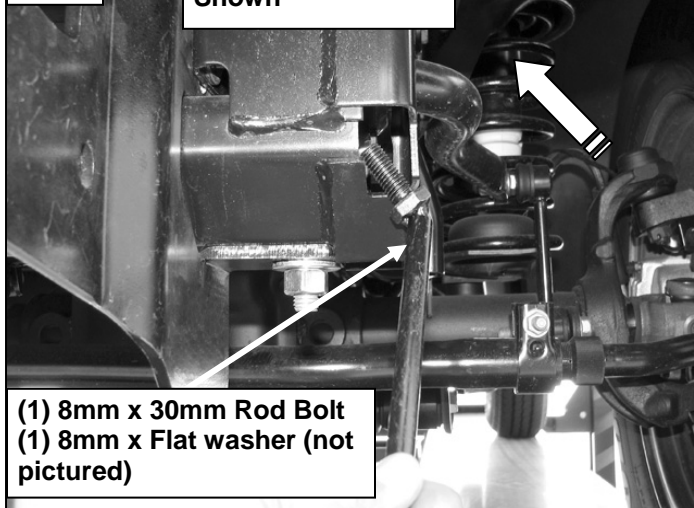
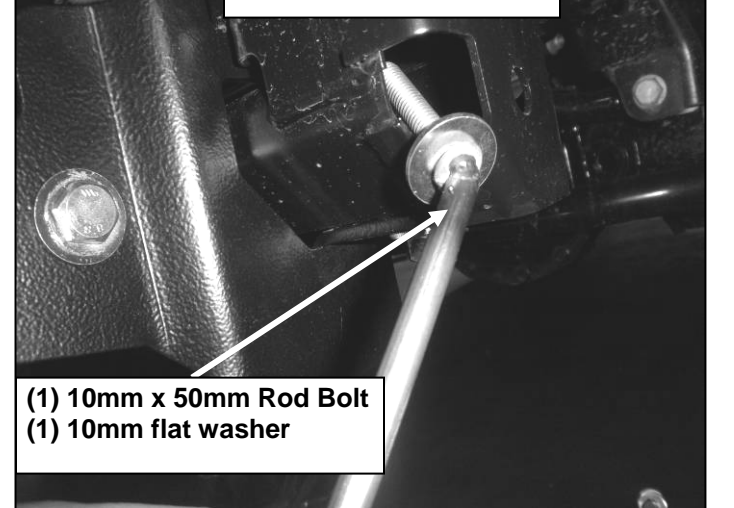

Fig 8 2007-11 Driver side Shown



- (1) 8mm x 30mm Rod Bolt
- (1) 8mm x Flat washer (not pictured)

Fig 9 2012 Driver side Shown



- (1) 10mm x 50mm Rod Bolt
- (1) 10mm flat washer

Driver Side Installation Pictured

Fig10

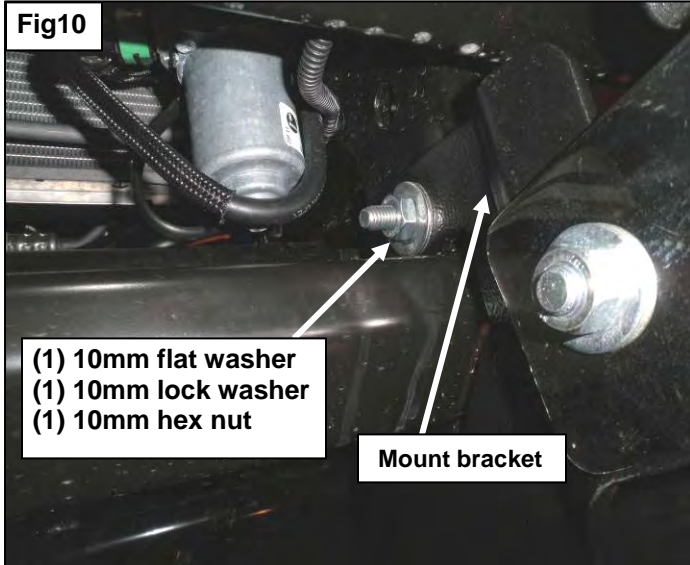

Fig11

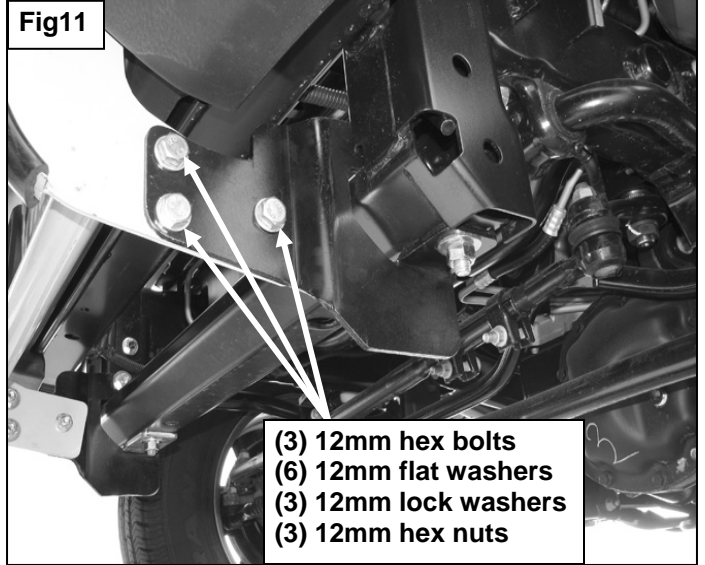
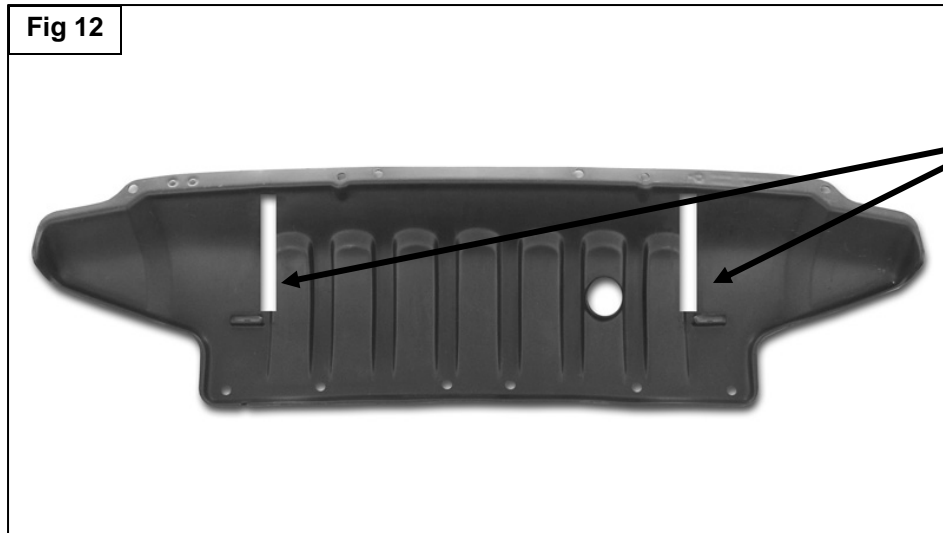

Fig 12



Once the Mounting Brackets have been installed and checked for alignment, hold the splash guard up into position and mark the cut area on the inside of the guard. Start with a small opening and slowly enlarge the opening to get the best fit around the brackets. Area cut from guard pictured for example only. (Interior view)

Installation complete

