



Installation Instructions

Jeep JK Front Grumper

Product Number: GR1010

Application: 2007- 2016

SAFETY

Your safety and the safety of others is very important.

- In order to help you make informed decisions about safety, we have provided installation instructions and other information.
- These instructions alert you to potential hazards that could hurt you or others.
- Please do a job safety analysis (JSA) before each task to identify potential hazards for your situation and remove/protect against them.
- You must use your own good judgment, and take your time.

Read and understand all safety precautions and instructions before installing this product.

THIS PRODUCT IS FOR OFFROAD USE ONLY. ALL LIABILITY FOR INSTALLATION AND USE RESTS WITH THE OWNER.

CARELESS INSTALLATION AND OPERATION CAN RESULT IN SERIOUS INJURY OR EQUIPMENT DAMAGE.

Injury hazard

Failure to observe these instructions could lead to severe injury or death.

- Always** remove jewelry and wear eye protection.
- Always** use extreme caution when jacking up a vehicle for work. Set emergency brake and use tire blocks. Locate and use the vehicle manufacturers designated lifting points. Use jack stands.
- Always** use appropriate and adequate care in lifting components into place.
- Always** insure components will remain secure during installation and operation.
- Always** wear safety glasses when installing this kit. A drilling operation will cause flying metal chips. Flying chips can cause serious eye injury.
- Always** use extreme caution when drilling on a vehicle. Thoroughly inspect the area to be drilled (on both sides of material) prior to drilling, and relocate any objects that may be damaged.
- Always** use extreme caution when cutting and trimming during fitting.
- Always** tighten all nuts and bolts securely per installation instructions.
- Always** route electrical cables carefully. Avoid moving parts, components that become hot and rough or sharp edges.
- Always** insulate and protect all exposed wiring and electrical terminals.
- Always** perform regular inspections and maintenance on mounts and related hardware.





Installation Instructions

Jeep JK Front Grumper

Product Number: GR1010

Application: 2007- 2016

I. Overview

Congratulations on your new purchase of the industries' best and only Jeep JK front Full Width Grumper! This Full Width Grumper has been **engineered** for strength while reducing weight.

Your Full Width Grumper was designed, CNC laser cut, fabricated, and powder coated... all in the U.S.A.

Enjoy the fit and finish of a quality JK front Full Width Grumper from Fab Fours Inc!

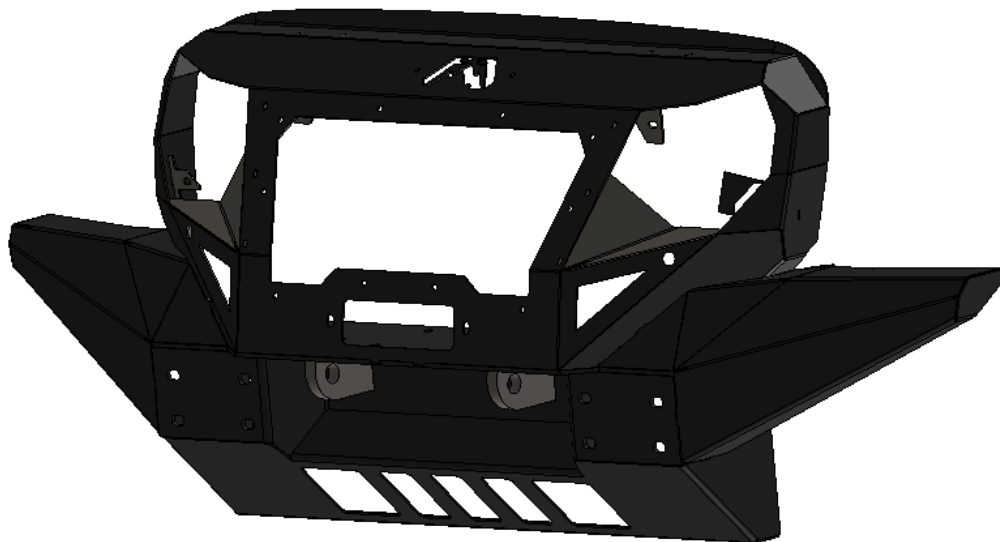



Installation Instructions

Jeep JK Front Grumper

Product Number: GR1010

Application: 2007- 2016

II. Tools Required

- Flat Head Screwdriver
- Phillips Screwdriver
- Socket Wrench With Extension
- 18mm & 19mm Sockets
- 3/4", 1/2" Sockets
- 3/4" Deep Socket
- 17/32 Drill Bit
- 7/16" Open End Wrench
- Plastic Rivet "Christmas Tree" Removal Tool
- 3/16" Allen Wrench
- 5/32" Allen Wrench

III. Vehicle Preparation

1. Remove (4) dart clips from underside of OEM grille/skid plate.
2. Remove (2) dart clips from back side of plastic skid plate.
3. Disconnect fog light harness from back of each fog lamp (if applicable).
4. Remove (8) nuts from studs using 18mm socket. (Ref. Figure 1)



Figure 1





Installation Instructions

Jeep JK Front Grumper

Product Number: GR1010

Application: 2007- 2016

5. Slide bumper forward slightly so that the studs still pass through frame but the bumper rocks forward. Remove fog harness retainer clips from bumper.
6. Remove OEM bumper and set aside. (Ref. Figure 2)



Figure 2

7. Remove two dart clips from top bumper trim plastic using Phillips screwdriver. Set trim aside as it will not be re-used. (Ref. Figure 3)





Installation Instructions

Jeep JK Front Grumper

Product Number: GR1010

Application: 2007- 2016



Figure 3

8. Remove the turn signal from the back side of grille, this is done by rotating and pulling light out. (Ref. Figure 4)

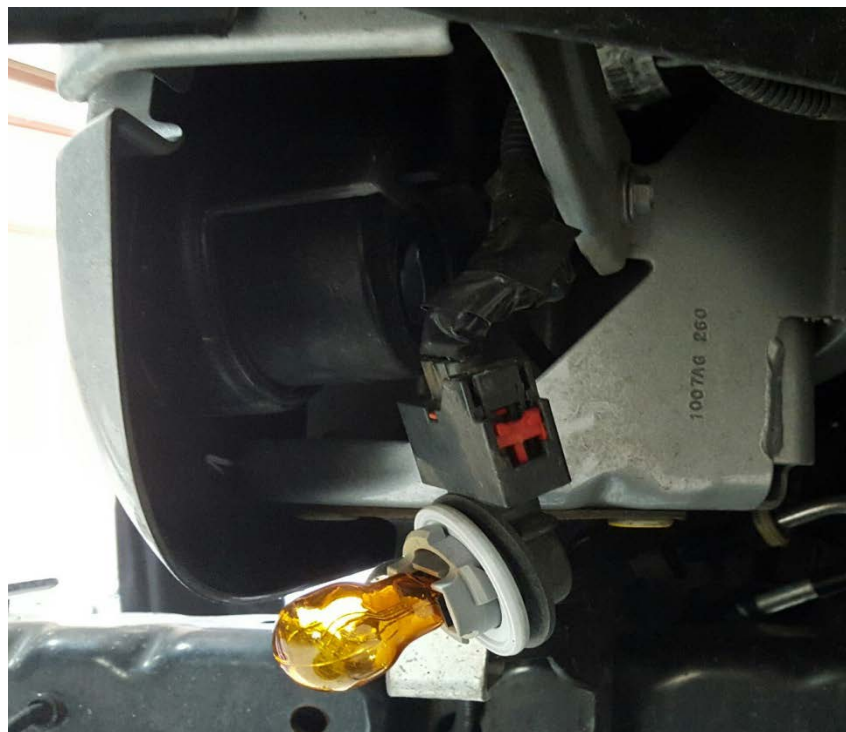

Figure 4





Installation Instructions

Jeep JK Front Grumper

Product Number: GR1010

Application: 2007- 2016

9. Opening the hood, locate and remove the push pins at the top of the grille as shown in Figure 5.



Figure 5





Installation Instructions

Jeep JK Front Grumper

Product Number: GR1010

Application: 2007- 2016

10. At this point there are several clips at the base of the grille. Pulling firmly at this location the grille should now be free. (Ref. Figure 6)



Figure 6





Installation Instructions

Jeep JK Front Grumper

Product Number: GR1010

Application: 2007- 2016

IV. Grumper Preparation

1. Remove the Grumper from the shipping carton. Lay all items out on a non-scratch surface to prevent damage to the powder coating.
2. Using the 5/16" fasteners, install the headlight inserts, grille, and logo backer plates. (Ref. Figures 7 & 8)

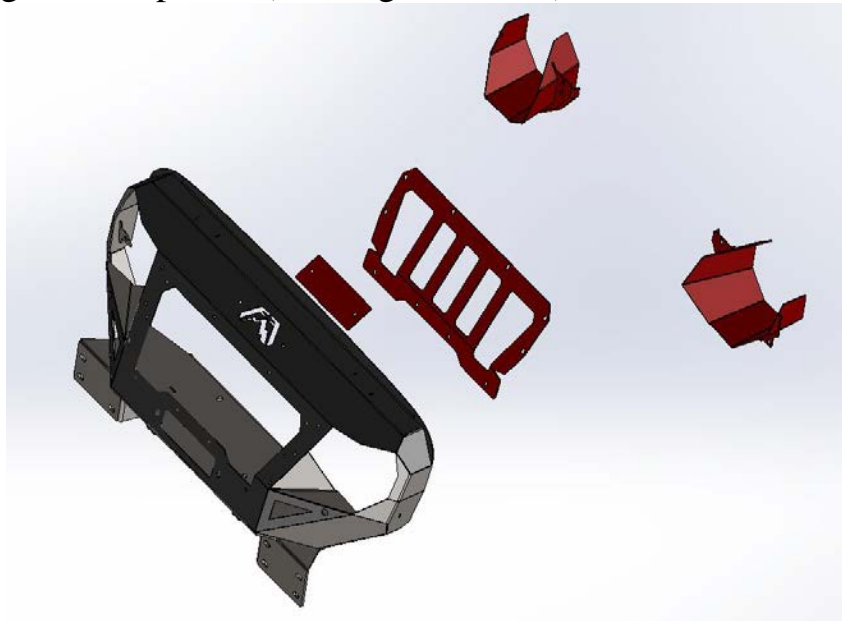

Figure 7

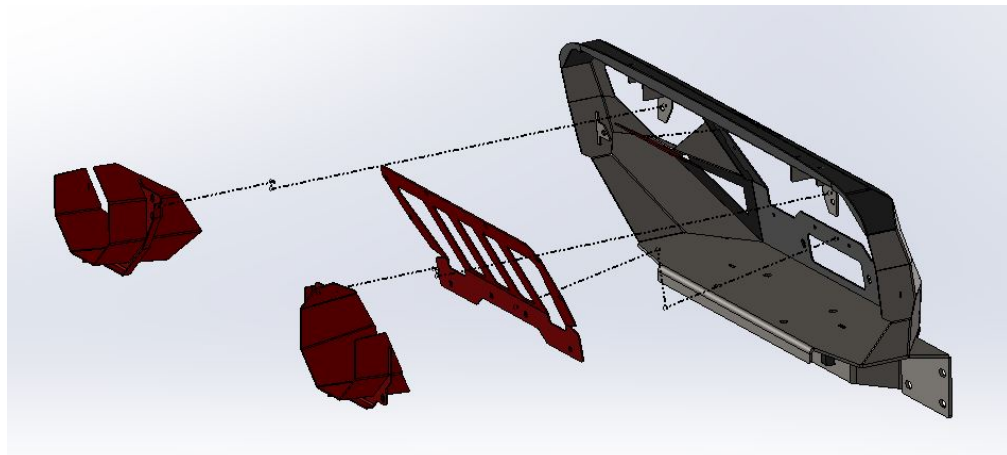

Figure 8





Installation Instructions

Jeep JK Front Grumper

Product Number: GR1010

Application: 2007- 2016

If installing winch, do so now. Follow instructions provided with winch. Remember to install fairlead onto front of Grumper.

3. At this point, wire provided turn signals and confirm they work before disconnecting and installing them into Fab Fours Grumper.
4. Follow the wiring diagram below. It is strongly recommended a multimeter or its equivalent is used to confirm wiring before splicing.

WIRE COLORS:

TURN SIGNALS
(Ref. Figures 11a-11b)

<u>WIRE</u>	<u>FAB FOURS</u>	<u>OEM COLOR</u>
High/Turn/Stop	Yellow	White/Pink (RH) White/Grey (LH)
Low/marker/clearance	Black	White/Tan (RH) White/Green (LH)
Ground	White	Black (RH) Black (LH)





Installation Instructions

Jeep JK Front Grumper

Product Number: GR1010

Application: 2007- 2016

Grumper Installation

1. Using a 9/16" bit, drill out the top outboard holes in the frame.
2. Lift Grumper and align mounting studs with holes in frame face plate (ref. figure 9).

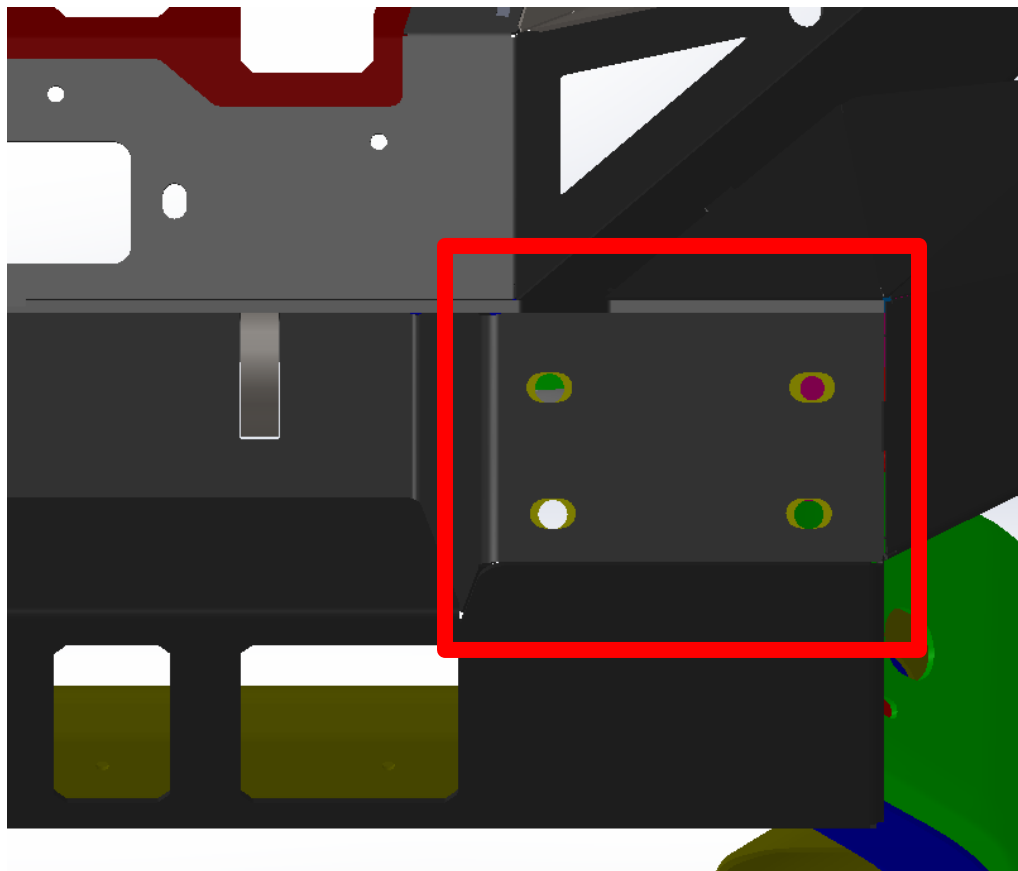

Figure 9

3. Secure loosely with supplied 1/2" bolts, flat washers, lock washer and nut. Do not tighten fully.
4. Because of the mounting system, little adjustment is necessary. Verify proper alignment and tighten all fasteners; for outer bolts





Installation Instructions

Jeep JK Front Grumper

Product Number: GR1010

Application: 2007- 2016

reach behind wings to access frame (ref. figure 10a) and for inner bolts reach through access slot on lower guard of grumper (ref. figure 10b). A deep $\frac{3}{4}$ " socket w/ a ratchet wrench is recommended.

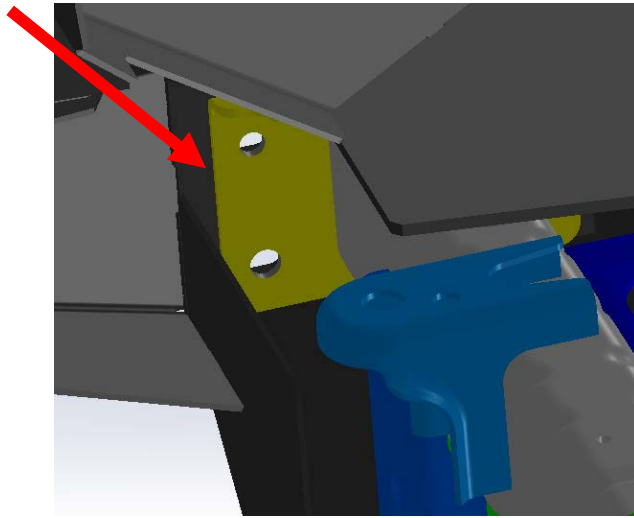

Figure 10a (inside view of frame outer)

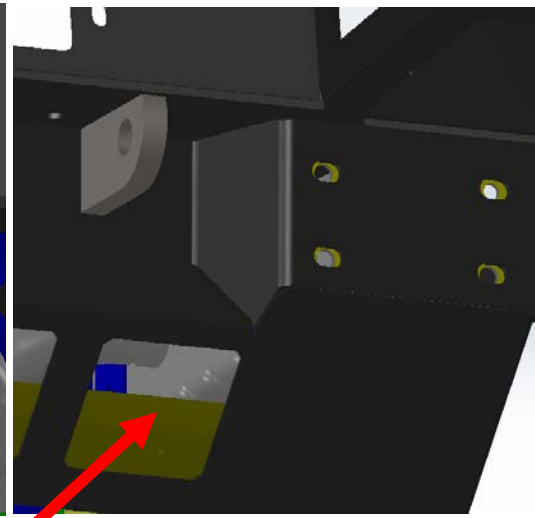

Figure 10b (inside view of frame outer)





Installation Instructions

Jeep JK Front Grumper

Product Number: GR1010

Application: 2007- 2016

V. Maintenance/Care

- Periodically check and tighten all fasteners.
- Stripped, fractured, or bent bolts or nuts need to be replaced.

VI. Contact Information

Fab Fours Inc.
1312 Camp Creek Rd.
Lancaster, SC 29720

Phone (866)-385-1905
Fax (866)-574-1424
Email Support@fabfours.com



More than expected... Better than expected

