

SIMPLY SUPERIOR.

3.5" J-KONTROL SUSPENSION SYSTEM

3.5" J-KONNECT SUSPENSION SYSTEM

**2007-2015 JEEP JK WRANGLER
2 & 4 DOOR MODELS**

JSPEC2353

www.jksmfg.com | jks@sporttruckusainc.com | 517-278-1226

RV. 041516

GETTING STARTED

Read all warnings, instructions, notes and cautions before you begin the installation.

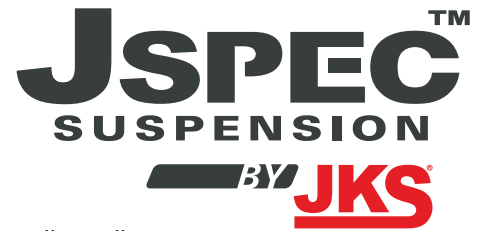

WHO SHOULD INSTALL THIS?

We recommend that this system be installed by a professional mechanic. The installer will need professional knowledge of special tools required for installation as well as assembly and disassembly procedures.

STAYING SAFE AND LEGAL

- If you fail to drive your lifted and modified vehicle safely it may result in serious injury or death.
- Exercise caution: A lifted vehicle is at greater risk for rollovers or loss of control, especially during abrupt maneuvers.
- Always wear your seat belt, reduce your speed and avoid sharp turns.
- Never operate your vehicle under the influence of drugs or alcohol.
- Consult local and state laws for the legality of your ride height.

BEFORE YOU BEGIN INSTALLATION

- Needed items: OE service manual for your vehicle, safety glasses, and any special tools as indicated in these instructions as well as the following tools: assorted metric and standard wrenches, hammer, hydraulic floor jack and a set of jack stands.
- Ride Height: Measure the initial ride height of your vehicle prior to installation. Final ride height may vary depending on the factory height of your vehicle.
- Tires and rims: Larger tire and rim combinations can increase leverage and cause additional stress to suspension, steering, and related components. When installing larger than OE tires and rims, the following components should be inspected for wear every 2500-5000 miles: ball joints, tie rod ends, wheel bearings, track bar bushings, pitman arm.
- Drive line vibrations: Some vehicles may experience drive line vibration after installation of this suspension system. Possible remedies for this include: tuning angles, replacement of slider on shaft, lengthening or truing of shaft, and/or replacing u-joints.
- Installation without a hoist: We recommend completing the rear alterations first if no hoist is available.



TRACTION CONTROL COMPLIANT

In an effort to reduce the risk of rollover crashes the National Highway Traffic Safety Administration (NHTSA) established the Federal Motor Vehicle Safety Standard (FMVSS) No. 126 requiring all new passenger vehicles under 10,000 lbs GVWR include an electronic stability control (ESC) system as standard equipment. Effective August 2012 this law requires aftermarket products to be compliant with these same standards.

VISIT 560PLUS.COM FOR MORE INFORMATION!

THANK YOU FOR CHOOSING JSPEC SUSPENSION

TIRE FITMENT

2.5" LIFT

33x12.50 on 16x8 with 4.5" backspacing

3.5" LIFT

35x12.50 on 16x8 with 4.5" backspacing

SPECIAL TOOLS REQUIRED

Torque Wrench

7/8" Step Drill (Included)

5/16" Drill (Bump Stop Extensions)

INSTALLATION TIME

Approximately 5-6 hours

BEFORE YOU BEGIN

2012-14 models using the stock front driveshaft will require exhaust extension kit JKS8150.

The 7/8" step drill recommended for installation of the tie rod flip adapter is part # JKS1699.

01. PRE-INSTALLATION

- a. Measure from the center of the wheel up to the bottom edge of the wheel opening.

	Drv	Pass
Front	<input type="text"/>	<input type="text"/>
Rear	<input type="text"/>	<input type="text"/>

02. REAR DISASSEMBLY

- a. Disconnect the track bar at the axle with the vehicle still on the ground using a 21mm socket. Save bolt and nut tab.
b. Raise and support the vehicle with jack stands positioned in front of the lower control arm brackets. Remove the tires.
c. Remove the parking brake cable bracket (10mm) [1]. Save nuts.
d. Remove the bolts holding the brake lines to the frame (10mm) [2].

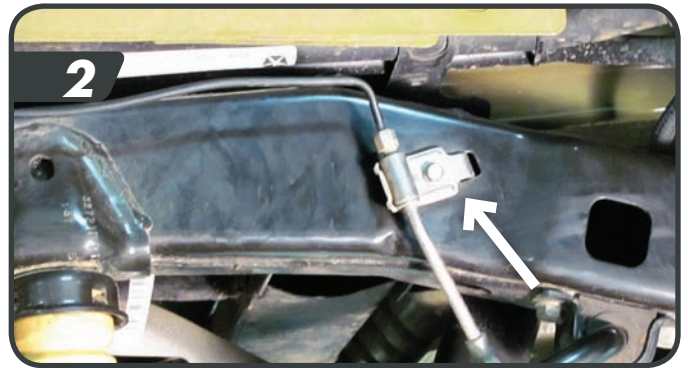
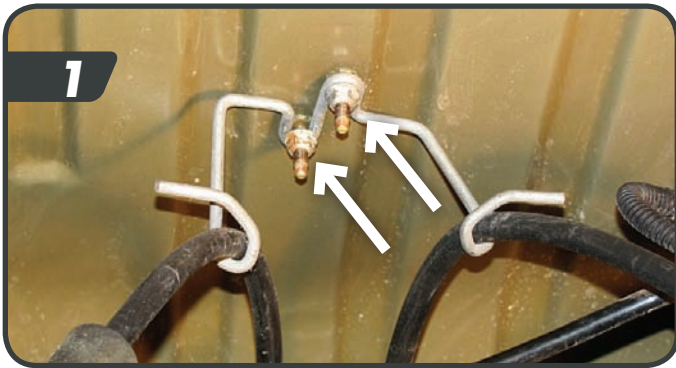

- e. Using a clip removal tool or pliers, remove the wheel speed sensor wiring from the bottom of the frame to gain additional slack [3].
f. Support the axle with a jack under the center of the differential and remove the shocks from the frame (16mm) and axle (18mm), save hardware [4].

02. REAR DISASSEMBLY (CONT.)

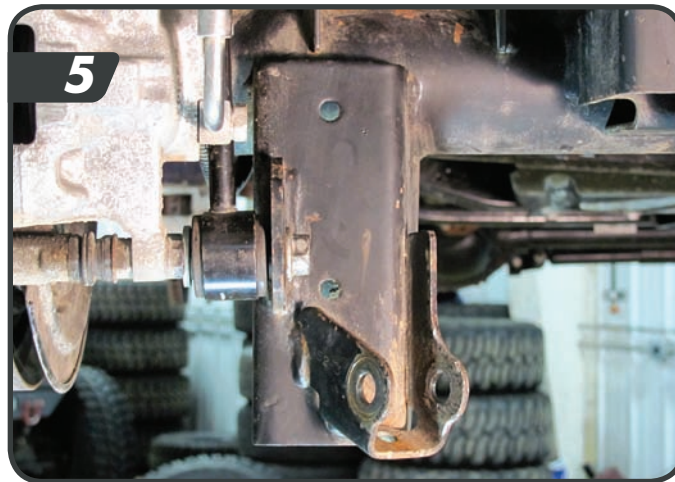
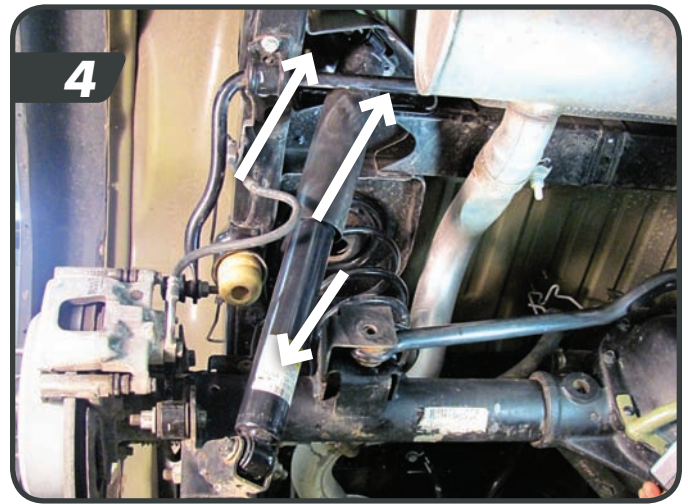
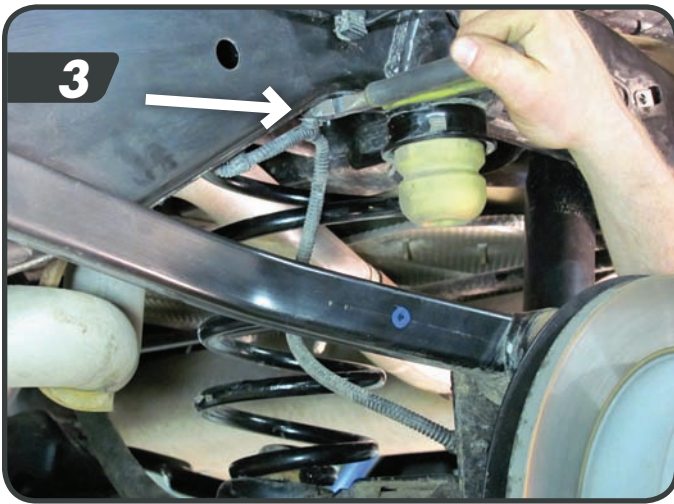

- g. Rubicon models: Disconnect the locker wires from the differential.
- h. Remove the sway bar links from the axle and save hardware (18mm) [5].
- i. Lower the axle enough to remove the factory springs. Make sure there is adequate slack on all wires.

03. REAR INSTALLATION

COIL SPRINGS, SWAY BAR LINKS, BUMP STOPS

Rear Bump stop spacers 01978B will require bolt pack J106

- a. Install the shorter pair of JSPEC coils springs into the rear of the vehicle with the orientation as shown. Raise the axle to compress the springs enough to hold it in place [1].
- b. The rear sway bar link axle mounts will need to be drilled to accommodate the added lift. Measure up 1-1/4" from the center of the OE mounting hole and drill a 1/2" hole at the mark. Paint bare metal. [2]

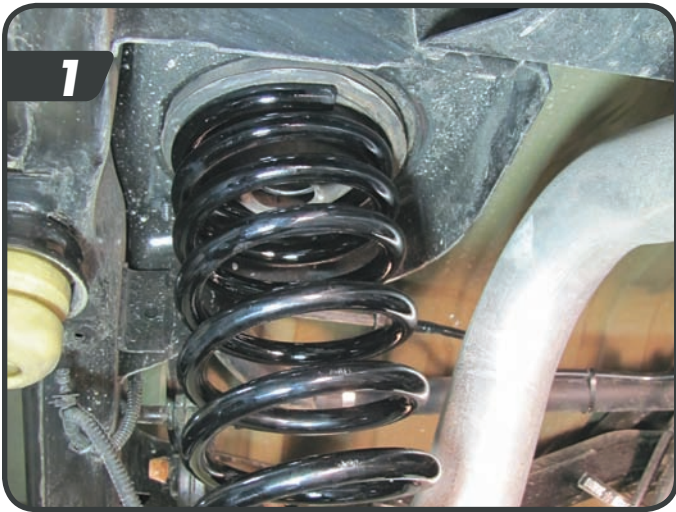

- c. Re-install sway bar links into the drilled hole using the factory hardware. [3]
- d. Install the rear bump stop spacers on the axle with the 2" tall orientation. Fasten the bump stop spacer to the axle with the 5/16" x 7/8" bolts, nuts and washers. Torque bolts to 20 ft-lbs. (1/2") [4]

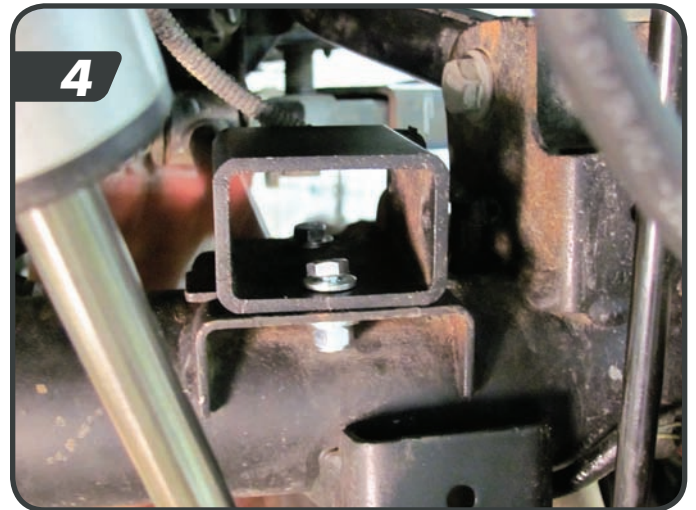
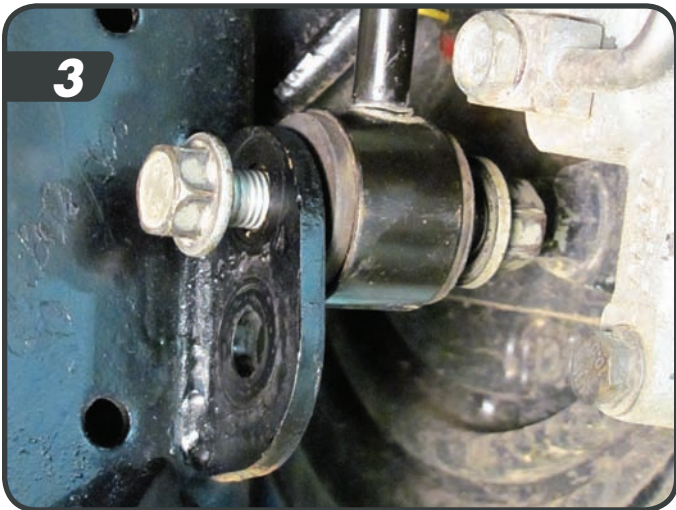

- e. Install the JSPEC shocks into the vehicle with the factory hardware.

03. REAR INSTALLATION

REAR BRAKE LINES & TRACK BAR BRACKET

Rear track bar bracket 03179 and riser brace 03217 will require bolt pack J103

Brake line brackets 03172 and 03173 will require bolt pack 768

- Position the rear track bar bracket on the axle above the factory bracket so radius edges rest on the axle tube and the rear track bar mount hole aligns with the hole in the bracket.
- JSpec 02451 Only - Place the track bar brace up to the axle and line it up with the original track bar mounting hole

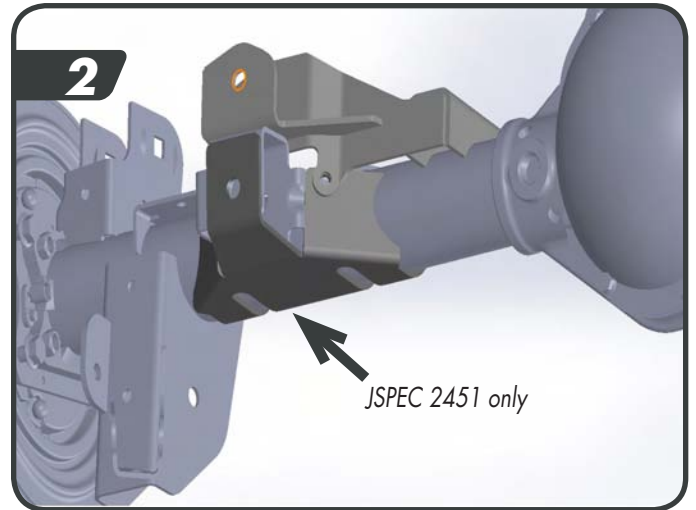

- Install the riser brace into the factory pocket using the factory track bar bolt and nut tab, do not tighten.
- Install two 3/8" x 1" bolts and washers from the inside of the track bar bracket and through the riser brace. Fasten with provided nuts and washers.
- Install the u-bolt, washers, and nylock nuts and fasten the relocation bracket to the axle tube.
- JSpec 02451 only - Fasten the track bar bracket to the track bar brace with the provided 3/8" x 1" bolt, nuts, and washers.
- Tighten the u-bolt hardware to 65 ft-lbs; the original track bar bolt to 125 ft-lbs; and the 3/8" hardware to 40 ft-lbs [1]. The track bar will be re-installed with the vehicle on the ground.
Note: The hole on the track bar bracket is only used when the JKS Rear Trackbar brace has been installed.
- Attach the brake line drop brackets to the brake line so the brake line tab fits in the drop bracket slot using the provided 1/4" hardware [3].

03. REAR INSTALLATION (CONT.)



- i. Attach the brackets to the frame using the factory hardware [2]. Re-install only the lower clip for the ABS wire.
- j. Rubicon models: Reattach the locker wire harness to the differential.
- k. Reattach the parking brake cable bracket to the floor using the factory nuts.
- l. Mount the tires and lower the vehicle to the ground.
- m. Install the rear track bar into the relocation bracket with the provide 9/16" x 3" bolt, nut, and washers.
Tip: Use an assistant to push on the body of the vehicle to help align the track bar in the bracket.
- n. Torque the track bar bolts to 110 ft-lbs.

04. FRONT DISASSEMBLY

- a. Disconnect the front track bar (21 mm) from the axle. Save bolt and nut tab.
- b. Raise the vehicle and support the frame with jack stands behind the front lower control arm pockets.
- c. Remove the wheels.
- d. Remove the front splash guard by removing the 6 plastic clips.
- e. Disconnect the steering drag link from the passenger side steering knuckle.
- f. Loosen the drag link adjustment collar (15mm) and un-thread the passenger side drag link from the adjusting collar. [1]
- g. Disconnect the sway bar links from the axle (18mm) and sway bar. Discard links and hardware. [2]

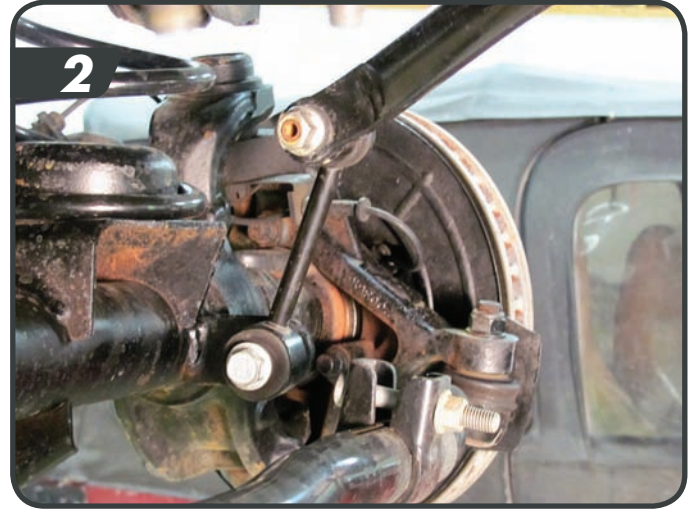
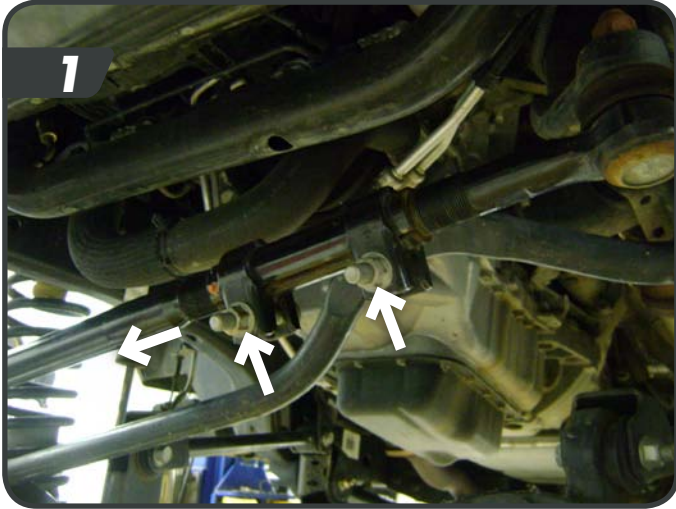

- h. Disconnect the track bar from the frame and remove it from the vehicle. Save hardware.
- i. Disconnect the front brake line brackets from the frame rails (10mm). 2011-14 models: Disconnect the brakelines from the axle below the coil spring. Save hardware.
- j. Rubicon models: Disconnect the front locker wires from the differential.
- k. Remove the 4 bolts mounting the front driveshaft to the pinion flange (15mm). This is done to ensure the driveshaft does not bind when installing the new springs. [3]

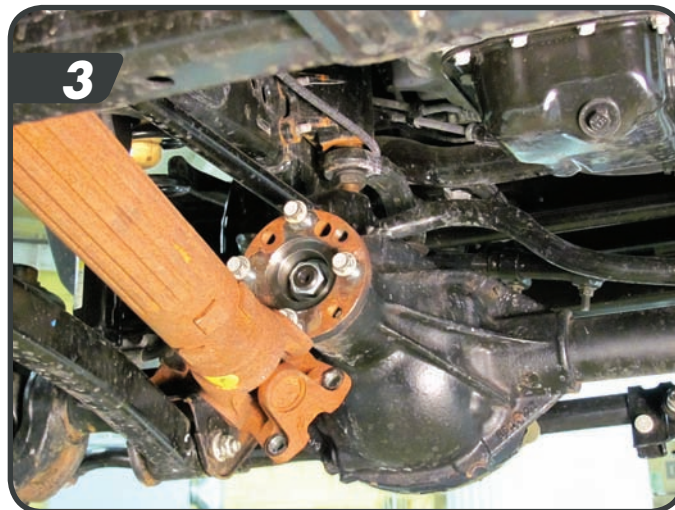

- l. Support the front axle with a hydraulic jack. Remove the front shocks from the vehicle using a 16mm wrench for the top and 18mm on the bottom. Save lower hardware.
- m. Lower the front axle and remove the coil springs. As the axle is lowered, verify all brake and electrical wires have enough slack and the driveshaft clears the pinion flange.

05. FRONT BUMP STOP & COIL SPRING INSTALLATION

3" Front bump stop extensions 03199 will require bolt pack J111

- Make a mark in the center of the lower coil spring mound pad. Drill a 5/16" hole at the mark. Using the provided 3/8" x 1" self tapping bolt (9/16"), tap a hole and remove the bolt. This hole will be used to attached the bump stop extension when the coils are installed. [1]
- Place the provided bump stop extension inside one of the JSPEC front coil springs. Note: Taller springs are for the front. Install the front coil springs with the bump stop extension. Make sure the spring is seated properly in the axle mount.
- Attach the bump stop extension to the axle through the hole that was made earlier using the provided 3/8" x 3-1/2" bolt and washer. Torque to approximately 25 ft-lbs. [2]

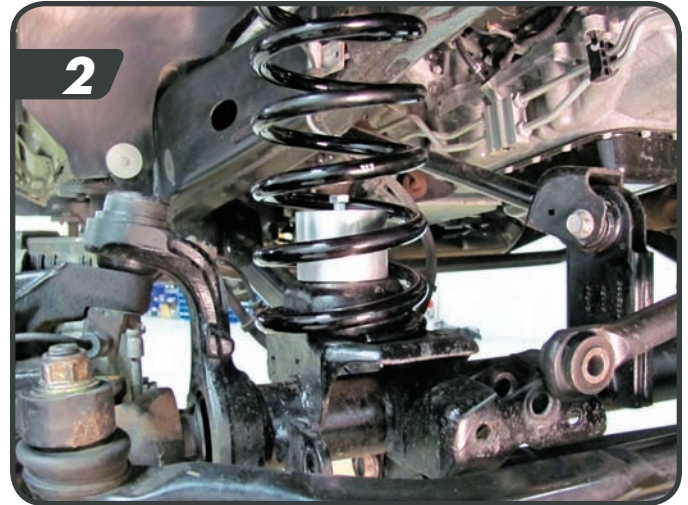

- Repeat the spring and bump stop installation on the other side of the vehicle.
- Install the new shocks with the factory lower hardware and the new upper bushings and hardware. Torque the lower bolt to 60 ft-lbs and the upper nut until the bushings begin to swell.

04. FRONT TRACK BAR GUSSET INSTALLATION (JSPEC 2451 ONLY)

- Remove the bolt mounting the steering stabilizer to the axle and the tie rod. Remove the steering stabilizer.
- Locate the front track bar gusset plate and place as shown on the bottom of the OE track bar mount. Clean up areas to be welded, and tack weld in place.

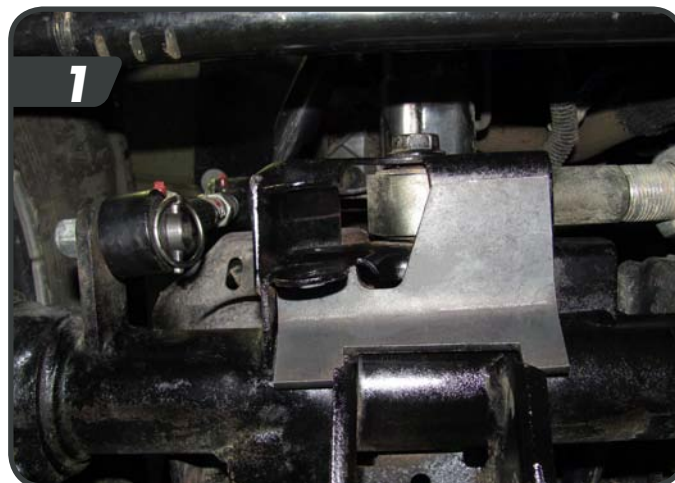

- Fully weld the edges of the gusset plate to the factory track bar mount and axle.

06. HIGH STEER INSTALLATION

DRAG LINK FLIP

- a. Drill out the tapered upper drag link hole on the passenger side steering knuckle to 7/8". A step drill with the largest size being 7/8" is recommended. Use care to drill as straight as possible to avoid an oversized hole and loose connection. [1]

Note: The 7/8 step drill is available through JKS as part number JKS1699.

- b. With the hole drilled to 7/8" (.875"), insert the provided tie rod flip adapter into the hole. from the top. The sleeve is designed to have a slight preload into a 7/8" hole to ensure a tight fit so gently tap it into place using a hammer. [2]



- c. Thread the replacement drag link into the adjustment collar so it matches the length of thread engagement of the tie rod end at the pitman arm.
- d. Fasten the drag link to the knuckle using the provided 9/16" washer from bolt pack J110. Torque the nut to 63 ft-lbs [3].

Important: Be sure to use the additional washer, it is a larger diameter to cover the 7/8" hole.

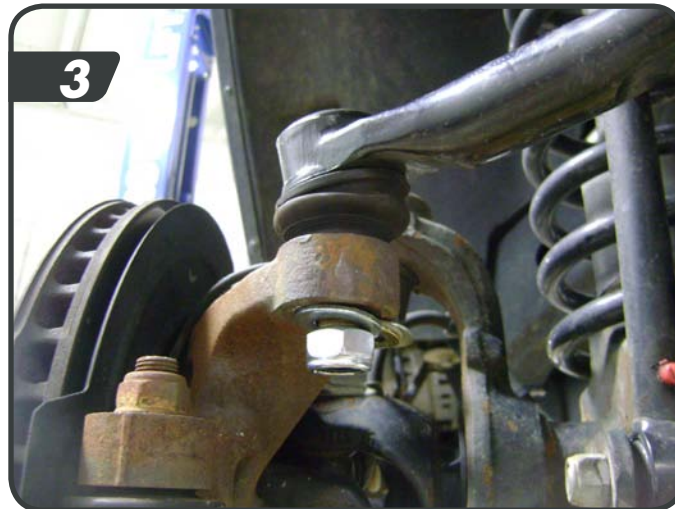

06. HIGH STEER INSTALLATION (CONT.)

The track bar bracket (03207) will require the spacer sleeve (69), u-bolt, and bolt pack J110

TRACK BAR BRACKET

- e. Place the track bar bracket onto the factory track bar mount. Get the two 3/8" bolts through the 2 outer front holes.
- f. Line up the original track bar mounting hole with the center hole in the bracket and insert the provided 3/4" x 1-3/8" sleeve. Loosely fasten the bracket through the original track bar hole with the provided 9/16" hardware. [4]



- g. Fasten the bracket to the axle with the 3/8" U-bolt, nylock nuts and washers.
- h. Torque the 3/8" hardware to 40 ft-lbs. and the 9/16" hardware to 125 ft-lbs.

HIGH CLEARANCE STEERING STABILIZER

- i. Loosen the clamp that mounts the steering stabilizer to the tie rod.
- j. Rotate the steering stabilizer tie rod mount until it lines up with the new mount on the track bar bracket.
- k. Place one of the 1/2" clear zinc USS washers on the factory tie rod mount followed by the steering stabilizer, another USS washer and the factory 12mm nut.



- l. If using the factory steering stabilizer, use the factory axle hardware to mount it to the bracket. If an aftermarket stabilizer is installed, use the provided 1/2" bolt, nut, and washers from bolt pack J110. The larger diameter washer is used on the bottom against the stabilizer bushing.

07. FRONT ADJUSTABLE TRACK BAR

- a. Insert the non adjustable end of the track bar into the frame mount with the clearance bend forward. Use factory hardware, do no tighten.
- b. Adjust the length of the track bar to 32-½". This is a starting point, final adjustment can be made once the vehicle is on the ground. Tighten the jam nut so the flats in the nut are parallel with the end to provide clearance to the high steer bracket. The track bar will be attached to the axle once the weight of the vehicle is on the suspension.

08. QUICKER DISCONNECT INSTALLATION

NON-RUBICON MODELS

- a. Mount the longer tapered mounting posts on the outboard side of the sway bar ensuring the click pin holes are parallel with the ground. Slide the polyurethane spacer on the pin and up against the sway bar. Apply Loctite to the tip of the mounting post and fasten with the ½" nylock nut, tighten to 65 ft-lbs. [1]

Note: A small screwdriver or punch inserted into the pin hole will keep the post from turning as you tighten it.

- b. Install the lower mounting posts into the factory sway bar link holes so they are pointing inboard and the pin holes are parallel to the ground. The passenger side post is squared off to provide clearance between the post and the OE track bar bracket. [2]

Note: In some cases a rotary grinder may be necessary to slightly open up the sway bar hole to clear the ½" bolt. This ensures a tight fit.

- c. Apply Loctite to the tip of the mounting post and fasten with the ½" nylock nut and tighten to 65 ft-lbs.
- d. Adjust the length of the quicker disconnects to 9" center to center. This is a starting point and can be fine tuned once the vehicle is on the ground.
- e. Slide the upper and lower ends of the disconnects over the mounting posts. Insert click pins to secure. [3]

RUBICON MODELS

Rubicon models have a factory electronic disconnect system. Follow these steps to solid mount your sway bar links.

Fixed sway bar link mounting will require bolt pack J105

- f. Adjust the length of the quicker disconnects to 9" center to center. This is a starting point and can be fine tuned once the vehicle is on the ground.
- g. Locate the ¾" x 1-¼" sleeve and insert them into the lower bushing of the sway bar link. Insert the longer sleeves into the upper bushing. Slide the polyurethane spacer onto the upper sleeve so it will mount to the swaybar.
- h. Using the ½" x 2-¼" bolts, nuts, and washers fasten the links to the axle.
- i. Using the ½" x 3" hardware, fasten the sway bar links to the sway bar.
- j. Torque ½" hardware to 65 ft-lbs.



9. FRONT BRAKE LINE BRACKETS

Brake line brackets 03174 and 03175 require bolt pack 768

- a. The front brake line brackets have a tab that inserts into the OE frame slot with the bracket towards the rear of the slot. Attach the drop brackets to the brake line so the brake line tab fits into the drop bracket slot using the provided ¼" hardware.
- b. Attach the brackets to the frame as shown using the factory hardware. You will need to slightly reform the hard lines.
- c. Verify the newly formed hard lines are not rubbing on the frame or shock mount.
- d. Slightly reform the 90 degree bend in the OE brake line down 10-15 degrees by hand to provide additional slack if necessary.
- e. 2011-14 models: Reattach the brakelines below the coil spring mount with the factory bolt.



10. CONTROL ARM BRACKET INSTALLATION (JSPEC2450 ONLY)

Control arm bracket installation will require bolt pack J109.

Installation of these brackets is best performed with the vehicle on the ground to limit axle movement when disconnecting the control arms.

- a. Working on one side at a time, remove the upper (18mm) and lower (21mm) control arm mounting bolts at the frame. Loosen the bolts at the axle, but do not remove.
- b. Install the control arm drop brackets as shown using the factory hardware. Torque lower bolt to 125 ft-lbs. Torque upper bolt to 75 ft-lbs. [1]
- c. Mount the lower control arm to the drop bracket using the provided 14mm hardware. Install the bolt from the outside in.
- d. Mount the upper control arm with the provided 12mm hardware. Install the bolt from the inside out. Use the upper hole for 2"-3.5" lifts and the lower hole for 4"+ lifts. [2]

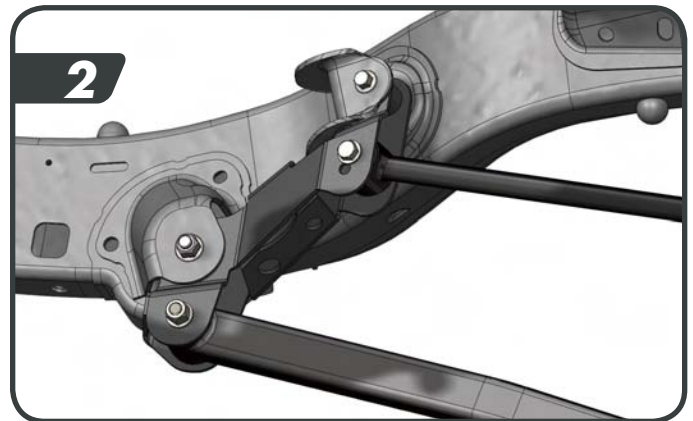
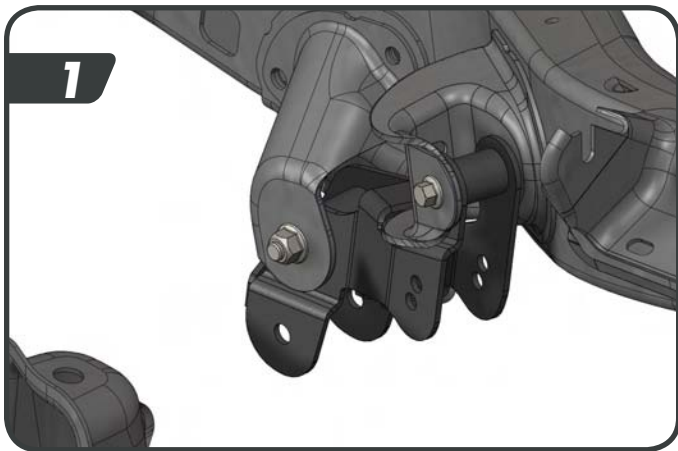

Note: You may find it easier to align the control arms to the mount by removing the opposite side upper control arm and adjusting the axle with a hydraulic jack.

- e. Repeat installation on other side of the vehicle.
- f. Torque both lower control arm bolts to 125 ft-lbs.
- g. Torque both upper control arm bolts to 75 ft-lbs.

11. J-LINK CONTROL ARM INSTALLATION (JSPEC2451 ONLY)

FRONT

- a. Raise the front axle with a hydraulic jack.
HINT: The axle housing should be evenly supported and the suspension at normal ride height. Do not attempt removal or installation with the suspension extended, or the axle drooped, as this will place tension on suspension arm mounting hardware
- b. Remove the lower suspension arm bolt and nut from the axle housing bracket. Retain the original mounting hardware
- c. Remove the bolt and nut from the chassis rail bracket. Retain the original mounting hardware
- d. Remove the original lower suspension arm from the vehicle
- e. Establish the J-Link control arm orientation so the bend goes inward (away from the tire) and the end closest to the bend mounts to the axle.

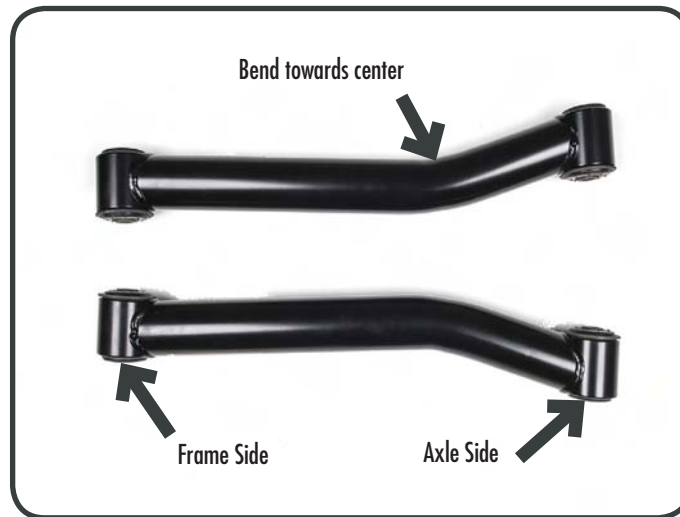

- f. Mount the control arm to the frame rail bracket. Install the original mounting bolt and nut. Finger tighten the bolt. DO NOT torque mounting hardware until instructed.
- g. Mount the control Arm to the axle housing bracket. Install the original mounting bolt and finger tighten the nut. DO NOT torque mounting hardware until instructed.

HINT: If mounting bolt is difficult to install due to misalignment of control arm bushing with mounting bracket, either adjust height of axle housing with hydraulic jack or move axle housing into position with a heavy-duty ratchet strap

- h. Repeat the J-Link Installation on the opposite side.

REAR

- a. Raise and support the vehicle chassis with jack stands positioned in front of the rear lower suspension arm brackets.
- b. Raise the axle housing with a hydraulic jack.
HINT: The axle housing should be evenly supported and the suspension at normal ride height. Do not attempt removal or installation with the suspension extended, or the axle drooped, as this will place tension on suspension arm mounting hardware.
- c. Remove the lower suspension arm bolt and nut from the axle housing bracket. Retain the original mounting hardware.
- d. Remove the bolt and flag nut from the chassis rail bracket. Retain the original mounting hardware.
- e. Remove the original lower suspension arm from the vehicle.
- f. Mount the control arm to the frame rail bracket. Install the original mounting bolt and flag nut. Finger tighten the bolt. DO NOT torque mounting hardware until instructed.
- g. Mount the Control Arm to the axle housing bracket. Install the original mounting bolt and finger tighten the nut. DO NOT torque mounting hardware until instructed.

HINT: If mounting bolt is difficult to install due to misalignment of Control Arm bushing with mounting bracket, either (1) adjust height of axle housing with hydraulic jack, (2) move axle housing into position with a heavy-duty ratchet strap, or (3) temporarily disconnect track bar until mounting holes align.

- h. Once all control arms have been installed, lower the vehicle to the ground until coil springs are supporting the full weight of vehicle.
- i. Using a torque wrench, tighten all mounting hardware to 125 ft-lbs.

12. FINAL FRONT INSTALLATION STEPS

- a. 2012-14 models, install the exhaust extensions using the instructions provided in the JKS8150 kit, sold separately.
- b. Rubicon models: Reattach the locker wire harness to the differential.
- c. Reattach the front driveshaft to the axle flange. Use Loctite on the bolts. Torque to 81 ft-lbs.
- a. Install the wheels and torque to the lug nuts to 125 ft-lbs.
- b. Attach the front track bar to the new high steer bracket with the 9/16" hardware. Have an assistant turn the steering wheel to aid in aligning the track bar bolt. Torque the frame and axle track bar bolts to 125 ft-lbs.
- c. Adjust the steering wheel to center with the adjustment collar on the drag link. Once centered torque the bolts to 26 ft-lbs.
- d. Check all hardware torque after 500 miles.
- e. Lower the vehicle to the ground and bounce the vehicle to settle the suspension. Torque the front lower control arm bolts at the axle to 110 ft-lbs.

13. STICKER INSTALLATION

Sticker installation should be performed when the temperature is above 60° F.



- a. Clean the areas thoroughly with rubbing alcohol to remove any buildup.
- b. Carefully place the sticker in the desired location.
- c. Rub gently to secure, then press firmly for 30 seconds.

KIT CONTENTS

JSPEC2351 COIL SPRINGS - 3.5" 2 DOOR

Part No.	Qty	Description
034313R	2	Front coil springs - 2 Door
034317R	2	Front coil springs - 2 Door

JSPEC2350 COIL SPRINGS - 3.5" 4 DOOR

Part No.	Qty	Description
034310R	2	Front coil springs - 4 Door
034318R	2	Rear coil springs - 4 Door

JSPEC2450 BOX KIT - J-KONTROL SYSTEM

Control Arm Correction Brackets

Part No.	Qty	Description
03211	1	J-Kontrol Arm Bracket - Drv
03212	1	J-Kontrol Arm Bracket - Pass
J109	1	Bolt Pack
	2	14mm-2.00 x 100mm bolt
	4	14mm flat washer
	2	14mm-2.00 prevailing torque nut
	2	12mm-1.75 x 80mm bolt
	4	12mm flat washer
	2	12mm-1.75 prevailing torque nut

High Steer Components

Part No.	Qty	Description
03196	1	Tie Rod Flip Adapter
382340334RB	1	3/8" x 2-3/4" x 3-3/4" U-bolt
03219	1	Drag Link
03207	1	Track Bar Bracket
69	1	3/4" x 1-3/8" Sleeve
J110	1	Bolt Pack
	2	9/16"-12 x 3" grade 8 bolt
	4	9/16" SAE washer
	2	9/16"-12 prevailing torque nut
	2	3/8"-16 x 1" grade 8 bolt
	2	3/8"-16 prevailing torque nut
	4	3/8" SAE flat washer
	2	3/8"-24 nylock nut
	2	3/8" SAE flat washer
	1	1/2"-13 x 2-1/4" grade 8 bolt
	1	1/2"-13 prevailing torque nut
	1	1/2" SAE washer
	1	7/16" USS flat washer
	2	7/16" USS flat washer
	1	9/16" SAE washer

Front Bump Stop Extensions

Part No.	Qty	Description
03199	1	3" Bump Stop Extension
J111	1	Bolt Pack
	2	3/8"-16 x 3-1/2" bolt
	2	3/8" SAE washer
	1	3/8"-16 x 3/4" self tapping bolt

JSPEC2451 BOX KIT - J-LINK SYSTEM

J-Link Lower Control Arms

Part No.	Qty	Description
A1007	2	J-Link Front Lower Control Arm
A1008	2	J-Link Rear Lower Control Arm

High Steer Components

Part No.	Qty	Description	Part No.	Qty	Description
03196	1	Tie Rod Flip Adapter	J110	1	Bolt Pack
1699	1	Step Drill		2	9/16"-12 x 3" grade 8 bolt
382340334RB	1	3/8" x 2-3/4" x 3-3/4" U-bolt		4	9/16" SAE washer
03219	1	Drag Link		2	9/16"-12 prevailing torque nut
03207	1	Track Bar Bracket		2	3/8"-16 x 1" grade 8 bolt
69	1	3/4" x 1-3/8" Sleeve		2	3/8"-16 prevailing torque nut
				4	3/8" SAE flat washer
				2	3/8"-24 nylock nut
				2	3/8" SAE flat washer
				1	1/2"-13 x 2-1/4" grade 8 bolt
				1	1/2"-13 prevailing torque nut
				1	1/2" SAE washer
				1	7/16" USS flat washer
				2	7/16" USS flat washer
				1	9/16" SAE washer

Bump Stop Extension

Part No.	Qty	Description	Part No.	Qty	Description
03199	1	3" Bump Stop Extension	J111	1	Bolt Pack
				2	3/8"-16 x 3-1/2" bolt
				2	3/8" SAE washer
				1	3/8"-16 x 3/4" self tapping bolt

Track Bar Gussets

Part No.	Qty	Description	Part No.	Qty	Description
03033	1	Rear Track Bar Brace	13105	1	3/8" x 1" Bolt
03254	1	Front Track Bar Brace	W38SAE	2	3/8" washer
			37264	1	3/8" lock nut

JSPEC2353 MAIN BOX KIT

Front Adjustable Track Bar

Part No.	Qty	Description
03044	1	Trackbar
03045	1	Adjusting Shaft Assembly
36274	1	1-1/4" Jam Nut
MB01B701740	2	Bushing

Quicker Sway Bar Disconnects

Part No.	Qty	Description
03005	2	Quick Pin
M03212-BK-01	2	Offset Polyurethane Spacer
03013	2	Stainless Steel Post - Upper
03018	1	Stainless Steel Post - Pass Lower
03017	1	Stainless Steel Post - Drv Lower
03010	2	Sway Bar Link - Female
03011	2	Sway Bar Link - Male
M00475-BK-01	4	Spherical Bushing
7050R	4	Grease Zerk Cap
7607	4	Grease Zerk
37130	4	1/2" Nylock Nut
36264	2	5/8" Jam Nut

Rubicon Fixed Mount Hardware

Part No.	Qty	Description
66	2	3/4" X 1.65" Sleeve
144	2	3/4" x 1.25" Sleeve
J105	1	Bolt Pack - Fixed Links
	2	1/2"-13 x 3" Bolt
	2	1/2"-13 x 2-1/4" Bolt
	4	1/2" Washer
	4	12mm Flat Washer
	2	1/2" Lock Nut

Rear Bump Stop Extensions

Part No.	Qty	Description
01928B	1	Rear bump stop spacer
J106	1	Bolt Pack - Rear bump stops
	4	5/16" x 3/4" bolt
	4	5/16" prevailing torque nut
	8	5/16" SAE washer

Rear Track Bar Bracket

Part No.	Qty	Description
03179	1	Rear track bar bracket
03217	1	Riser Brace Tab
123250500R	1	1/2" x 3-1/4" x 5" U-bolt
J103	1	Bolt pack - Rear track bar bracket
	2	1/2" nylock nut
	2	1/2" SAE washer
	2	3/8" x 1" bolt
	4	3/8" SAE washer
	2	3/8" prevailing torque nut
	1	9/16" x 3" bolt
	1	9/16"-12 lock nut
	2	9/16" SAE washer

Brake Line Brackets

Part No.	Qty	Description
03174	1	Front brake line bracket - Drv
03175	1	Front brake line bracket - Pass
03172	1	Rear brake line bracket - Drv
03173	1	Rear brake line bracket - Pass
768	2	Bolt Pack - Front brake line brackets
	2	1/4"-20 x 3/4" bolt
	2	1/4"-20 nylock nut
	4	1/4" USS washer