

Jeep Wrangler

i109-WRA 9" Restyle In-Dash System

Installation Manual

- Model: Wrangler
- Model Year: 2011-UP

(NOT COMPATIBLE WITH Uconnect®)

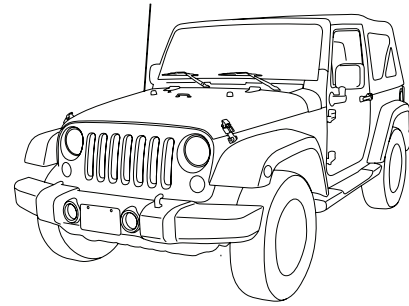

Jeep	Model	Year
	Wrangler	2011 - UP

* The specified vehicles have been tested and have met compatibility specs at the time of testing. Compatibility is not guaranteed if the manufacturer has made production changes to the listed vehicles above.

⚠ Warning: Before you begin wiring, remove the ground wire from the negative terminal of the battery. Failing to do so can lead to electric shock, injury or damage to equipment.



Introduction

- Design and specifications are subject to change without notice for improvement.





To Ensure Safe Use, Always Follow These Precautions

- The installation of this product requires specialized skills and experience. We recommend that you have the product installed by an Alpine authorized dealer.
- Before you use this product, be sure to carefully read this installation manual and the separate user's manual so that you can use the product correctly. Alpine Electronics bears no responsibility for problems that arise as a result of failure to follow the instructions in the manuals.
- This manual includes a number of symbols that are intended to help you use the product safely, to prevent harm to you and others, and to protect against damage to property. These symbols and their meanings are listed below. Make sure you fully understand these symbols before you begin reading the main text.

Explanations of Injury and Damage That May Result from Incorrect Use

 Warning	Ignoring the content marked by this indication and using the product incorrectly is expected to lead to death or serious injury.
 Caution	Ignoring the content marked by this indication and using the product incorrectly is only expected to lead to injury or property damage.

Types of Precautions

 Forbidden	Indicates actions that are forbidden (must not be performed)	 Mandatory	Indicates actions that are mandatory (must be performed)
 Forbidden	Indicates that disassembly is forbidden.		Marks content that should receive your full attention.

 **Warning**

Do not disassemble or modify the product. Doing so could lead to an accident, fire, or electric shock.



Forbidden

Store screws and other small objects where small children cannot reach them. If one of these small objects is swallowed, consult with a doctor immediately.



When replacing fuses, be sure to use fuses with the specified current rating. Failing to do so could lead to an accident or fire.



Forbidden



Mandatory

Only connect the product to a 12 VDC negative ground car. Failing to do so could lead to an accident or fire.



Mandatory

Before you begin wiring, remove the ground wire from the negative terminal of the battery. Failing to do so could lead to electric shock or injury.



Do not cut the insulation on a cord and take power from another device. Doing so could lead to fire or electric shock.



Forbidden

Do not install the product in a location where it will obstruct the driver's forward view; interfere with the operation of the steering wheel, gearshift, or the like; or pose a threat to passengers. Doing so could lead to an accident or injury.



Forbidden

When making a hole in the vehicle body, be careful to avoid damaging pipes, the fuel tank, electrical wiring, and the like. This kind of damage could lead to an accident or fire.



When installing and grounding the product, do not use any of the bolts or nuts of the steering wheel, brakes, fuel tank, or the like. Doing so could make the brakes stop working or lead to fire.



Forbidden

Do not install the product near the passenger-side airbag. Doing so could interfere with the operation of the airbag and lead to an accident or injury.



Forbidden

Bundle cords so that they don't interfere with driving. Wrapping cords around the steering wheel, gearshift, brake pedal, or the like, could lead to an accident or damage equipment.



 **Caution**

Connect the product properly according to the instructions. Failing to do so could lead to fire or an accident.



Forbidden

Do not sandwich cords between the seat railing or allow them to touch protrusions. Resulting breaks or shorts could lead to electric shock or fire.



Do not block vents or heat sinks. Doing so could lead to fire or damage equipment.



Use the accessories according to the instructions, and attach them securely. Failing to do so could lead to an accident or damage equipment.



Forbidden

Do not install the product where it may be exposed to water or in a place with high levels of humidity or dust. Doing so could lead to fire or damage equipment.









Forbidden

The installation and wiring of this product requires specialized skills and experience. Have the product installed by an Alpine authorized dealer.

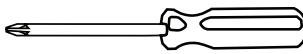

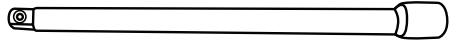
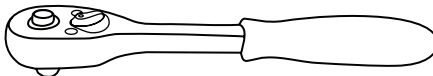
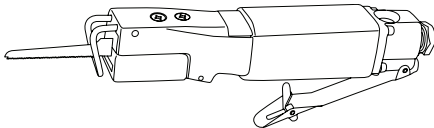

Tools Required



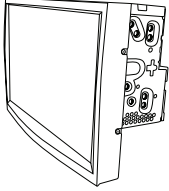
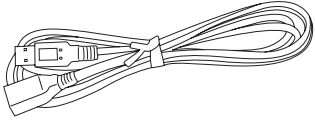
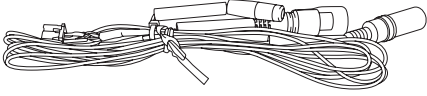

<p>Panel Removing Tool</p>	<p>7mm Sockets</p>	<p>#2 Phillips Screwdriver</p>
		
<p>10mm Sockets</p>	<p>Extension</p>	<p>Ratchet</p>
		
	<p>Air Saw</p>	<p>Wire Cutters</p>
		

Accessory List

Head Unit Box Parts (i109)

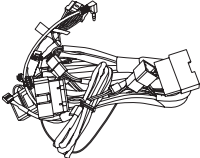
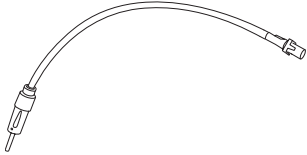
<p>Owner's Manual Card</p>	<p>i109 Head Unit</p>	<p>USB Extension Cable</p>
		
<p>AUX/CAMERA/REMOTE-OUT</p>	<p>Registration Cards</p>	<p>(4) 8mm Screws</p>
	 <p>Alpine Registration Card</p>	

iDatalink Maestro Box Parts (ALP-MRR2i/ALP-HRN-WRAi)

<p>Main Harness</p>	<p>Antenna Adapter</p>	<p>iDatalink Maestro Module</p>
		
	<p>Maestro USB Flashing Cable</p>	<p>OEM USB Adapter</p>
		

Installation Kit Parts (G-KTX-i109-WRA)

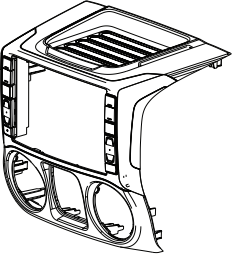
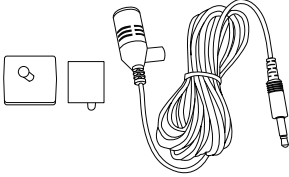
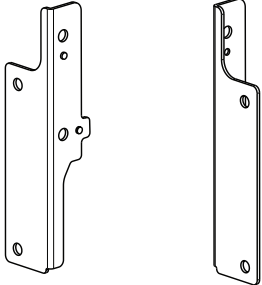
<p>i109-WRA Radio Dash Bezel</p>	<p>Microphone</p>	<p>Side Mounting Brackets</p>
		

Factory Unit Disassembly Process

- 1 Remove the rubber cover from the top center storage area and extract (1) 7mm screw.

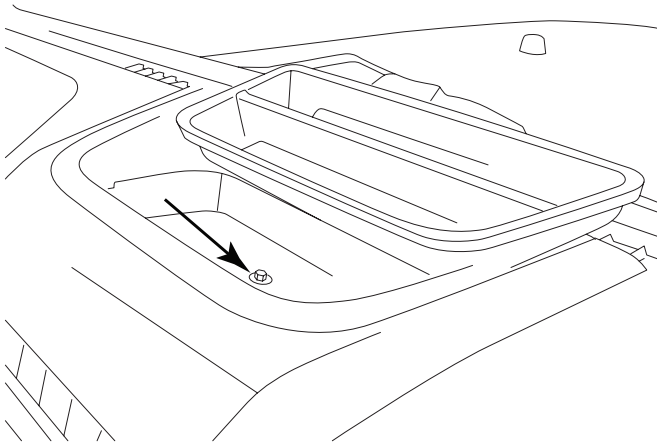

- 2 Remove the knee cover panel and extract (2) 7mm screws located to the right and left sides of the steering wheel column.



Left side of steering wheel column.

Right side of steering wheel column.

- 3 Remove the window switch pod using a panel removing tool and extract (1) 7mm screw.

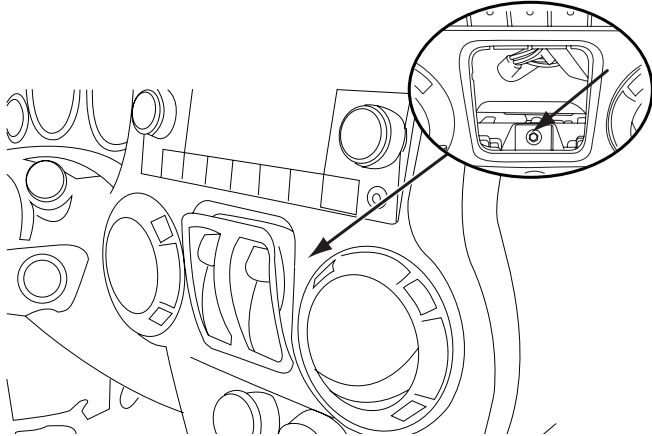

- 4 Remove the dash panel.

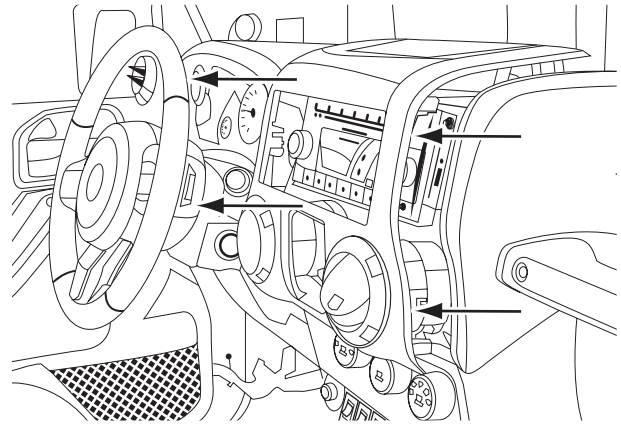

- 5 Extract (4) 7 mm screws and remove the factory radio.

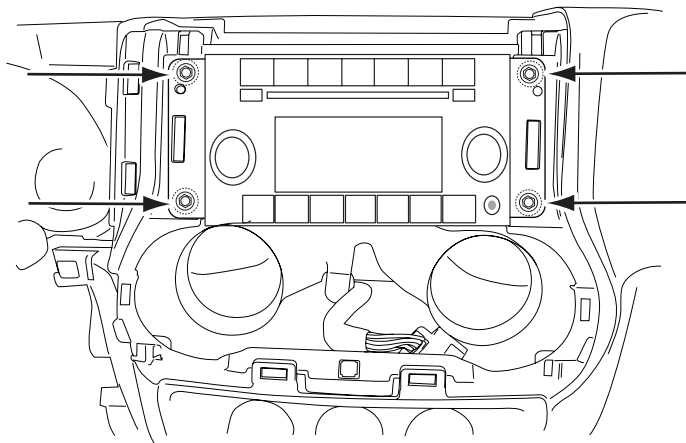

- 6 Extract (2) 7 mm screws from the factory radio bracket and remove it.

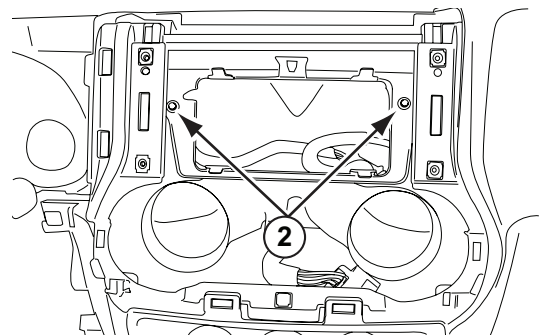

Programming the iDatalink Maestro Module

For this i109-WRA in-dash restyle system, the iDatalink Maestro Module has been pre-flashed. Follow the procedure below if the button configuration noted on page 12 needs to be changed.

1 INSTALL THE WEBLINK PLUG-IN

Go to: idatalinkmaestro.com/plugin and follow the installation steps.

Review the System Requirements before installing.

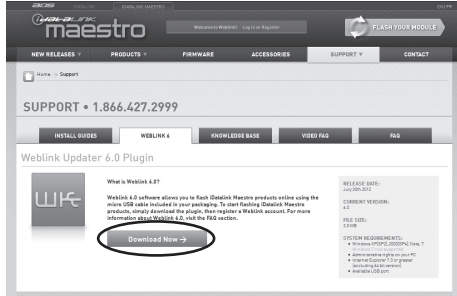

If the plugin is already installed, the caution, "The plugin is already installed" appears. Please skip to step 2.

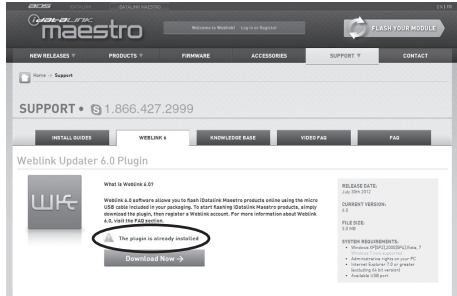

2 REGISTER A WEBLINK ACCOUNT

Go to: idatalinkmaestro.com/register and complete the registration process.

A confirmation email will be sent to you requiring validation.



For existing customers, click log in.



3 CONNECT YOUR MAESTRO MODULE

Use the included USB cable to connect your Maestro module to your PC.

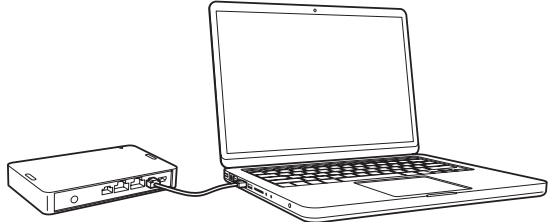

4 LOG INTO WEBLINK

Go to: idatalinkmaestro.com/login. Enter your username and password, then click OK.

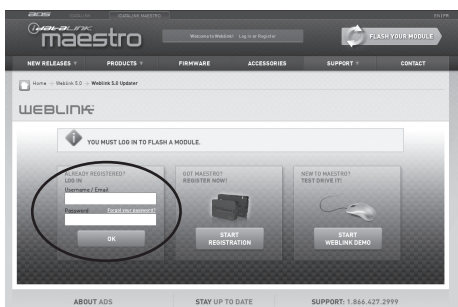

5 PROGRAM YOUR MODULE

Follow the programming steps for your vehicle.



6 Once Programming is complete "FLASHING COMPLETED!" will be displayed.

Proceed to the next page to complete installation.

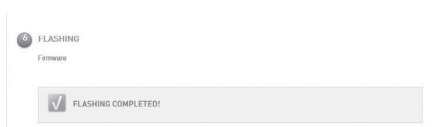

Installation Instructions

- 1** The factory dash panel needs to be trimmed to allow the new i109-WRA bezel to fit into place. Remove the highlighted area by cutting along the dashed line.

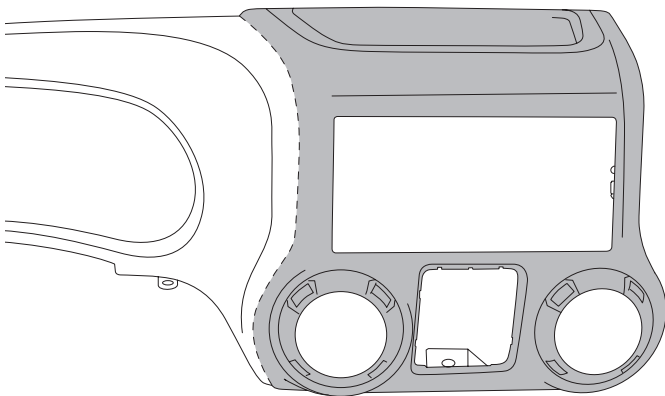

- 2** Remove the vents from the radio section on the OEM dash panel by pressing down on the lock tab and turning right. Mount vents on to the i109-WRA bezel.

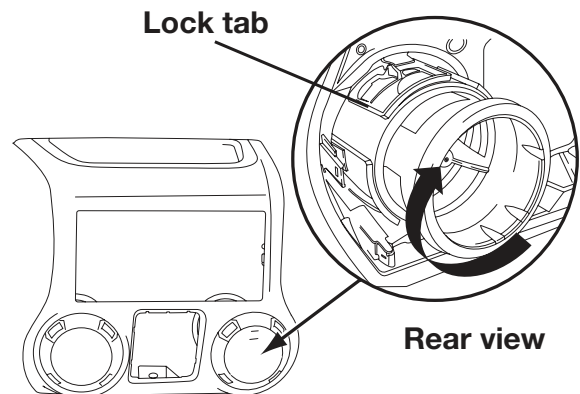

- 3** Use a cutting tool to trim the highlighted area shown below.

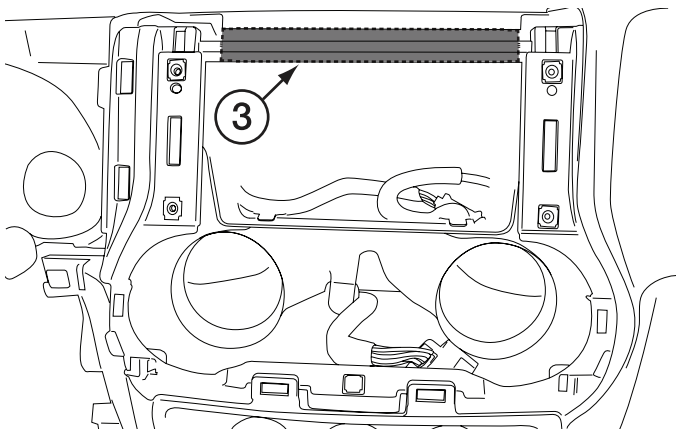

- 4** Mount the microphone as illustrated and run the cable to the radio cavity.

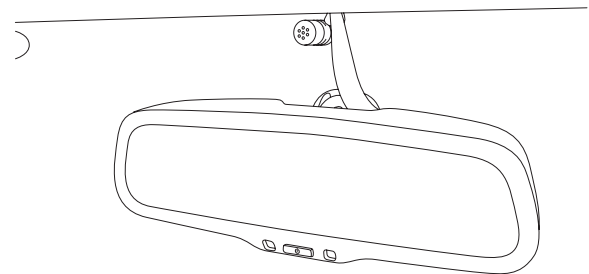

- 5** Attach iDataLink Maestro to main harness.

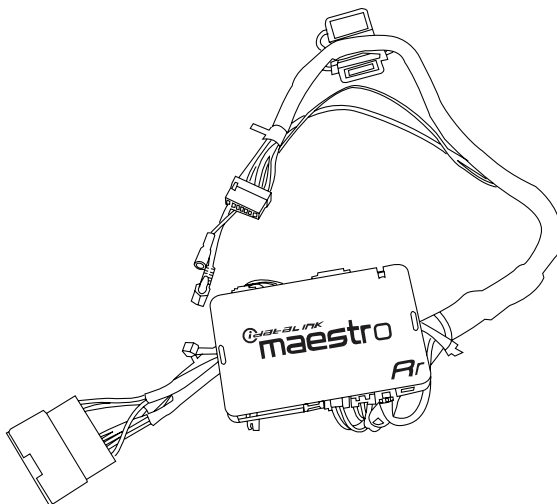

Installation Instructions

- 1 Attach the modified panel using the factory screws.
- 2 Attach the brackets using the provided (4) 8mm screws.

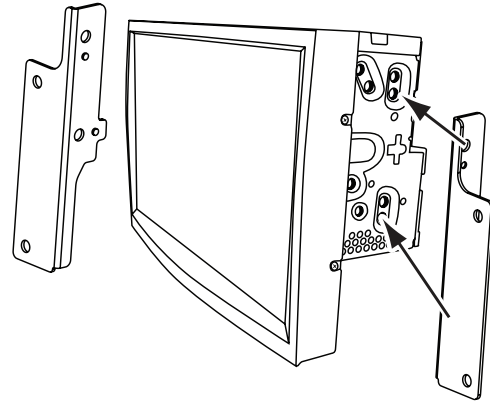
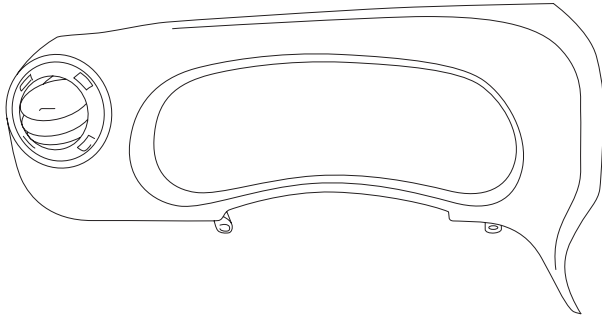

- 3 Route the USB extension cable to the glove box. Connect the main harness and adapters to the factory harness.

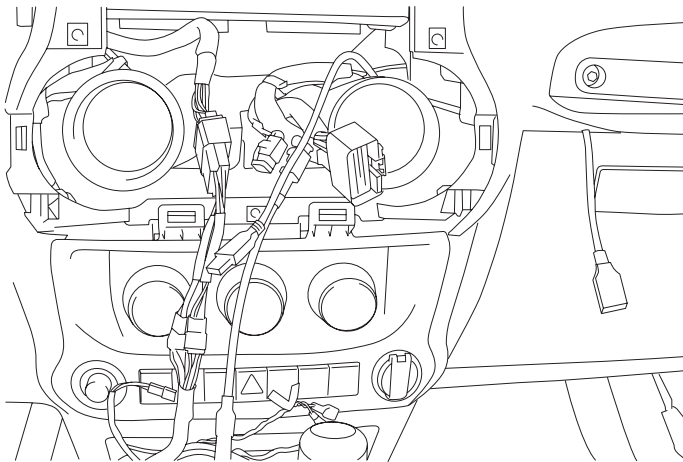

- 4 Secure the main harness to the antenna cable using a zip tie. (this will prevent the SW Remote connector from becoming loose)

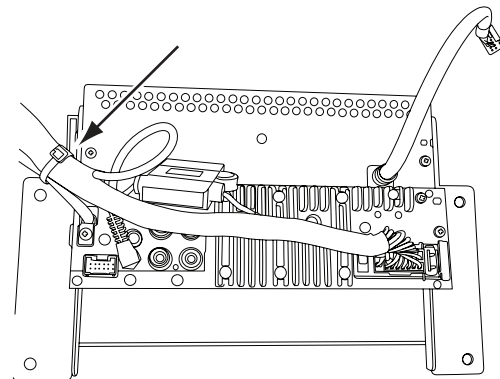

- 5 Route the key harness through the top-left side of i109 headunit. Mount the i109 headunit using (4) 7mm factory screws.

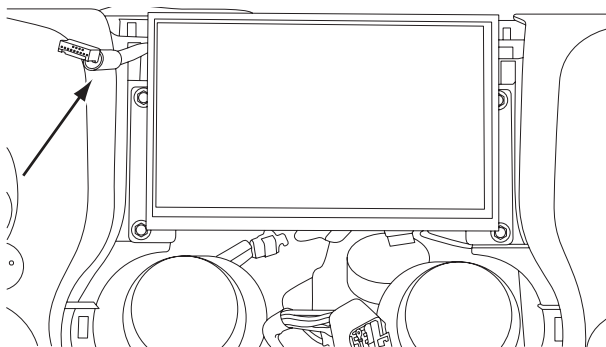

- 6 Connect the radio bezel and snap it into place.

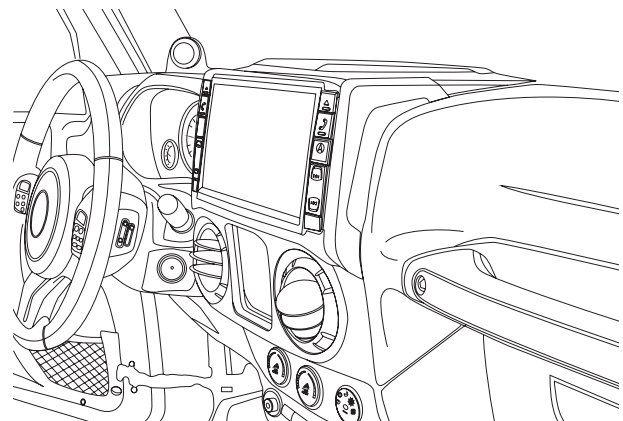

Exploded-View Diagram

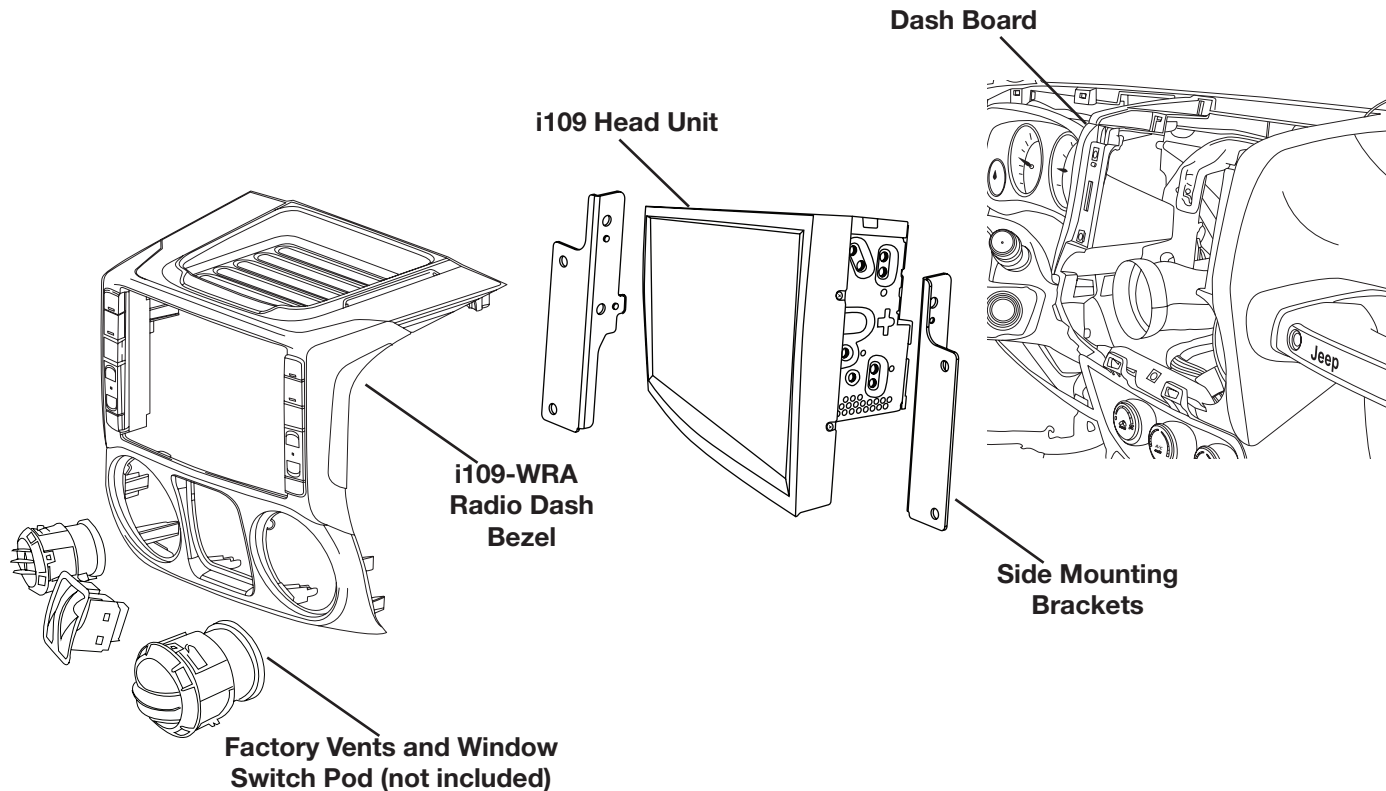

Bezel Wiring Diagram

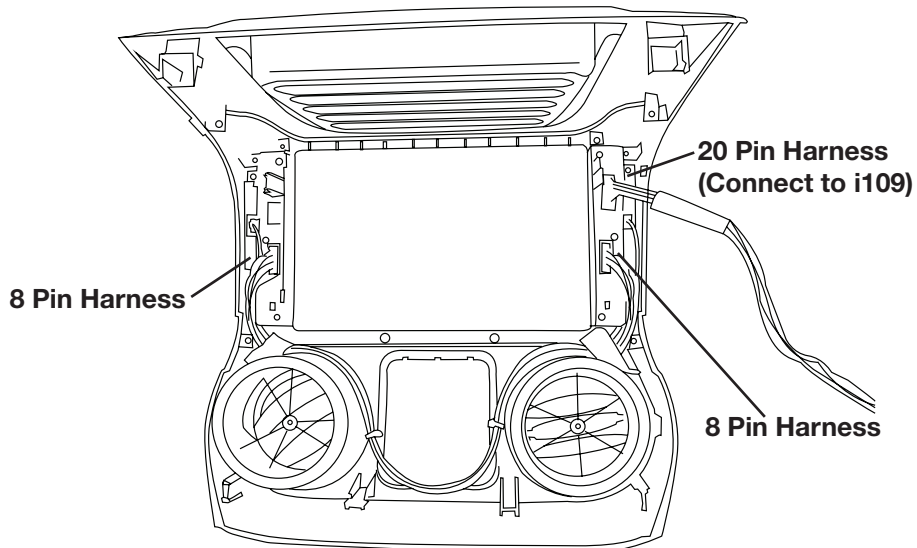

i109-WRA Wiring Diagram

To Vehicle Connectors

FACTORY AMPLIFIED VEHICLES

⚠ WARNING!
 Failure to follow this procedure will result in no audio from Navigation and Bluetooth sources.

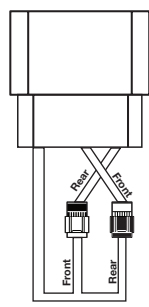

For factory amplified vehicles switch the speaker connectors, front to rear and rear to front.

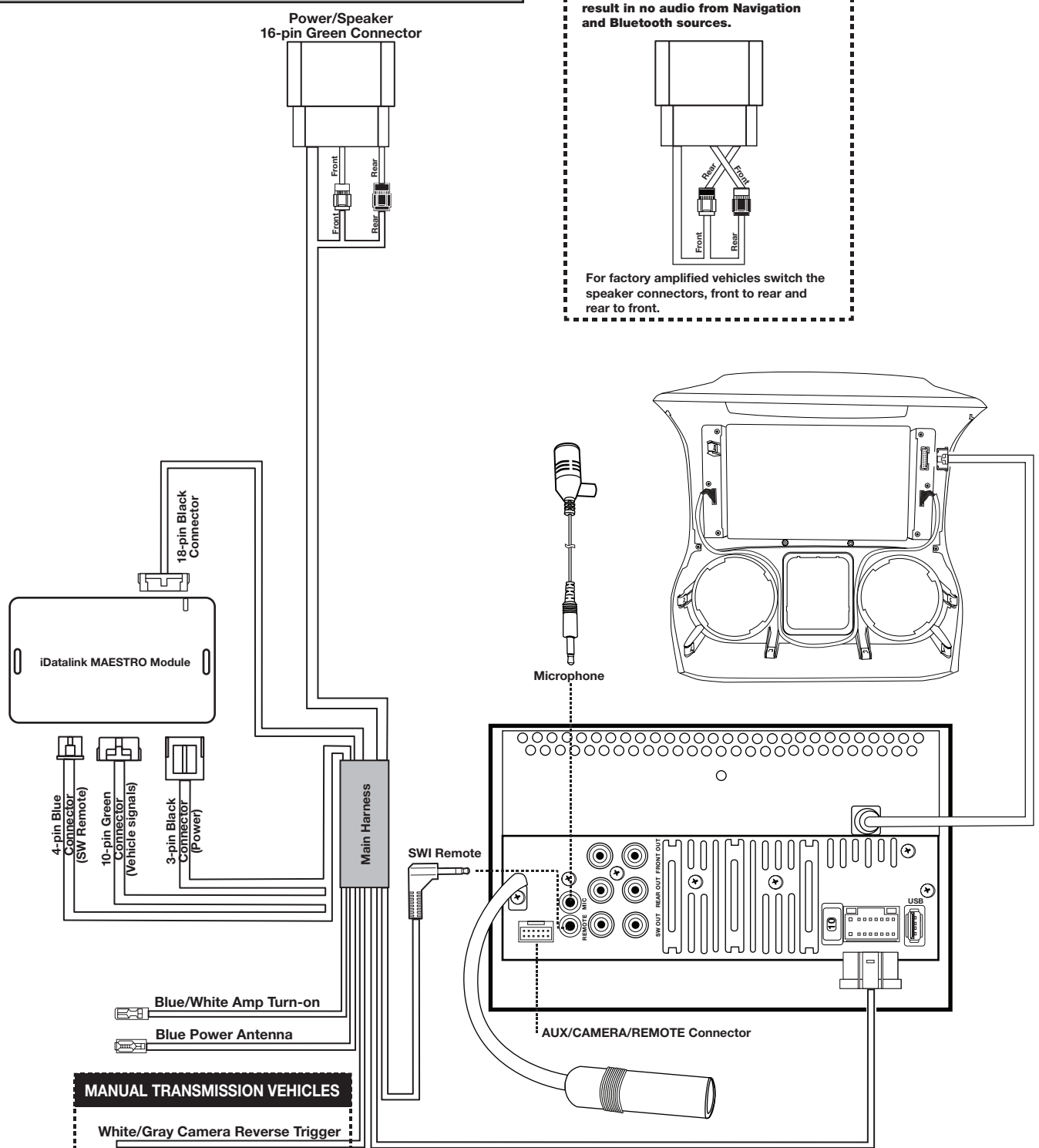

MANUAL TRANSMISSION VEHICLES

White/Gray Camera Reverse Trigger

For manual transmission vehicles ONLY. Connect the White/Gray wire to the White/Gray wire located on the passenger's kick panel.

Set Up Guide

- 1 Connect the NEGATIVE battery terminal back on.
- 2 Turn the vehicle's ignition switch to ACC.
- 3 Turn ON the i109-WRA by pressing any key.
- 4 Select the language and press OK.
- 5 Engage, release and engage the parking brake.
- 6 If a camera is present, turn it ON in the system menu. (HOME/⊙/APPLICATION/CAMERA)
- 7 Connect an iPhone and proceed to check the steering wheel controls following the chart below.

Steering Wheel Control Configuration

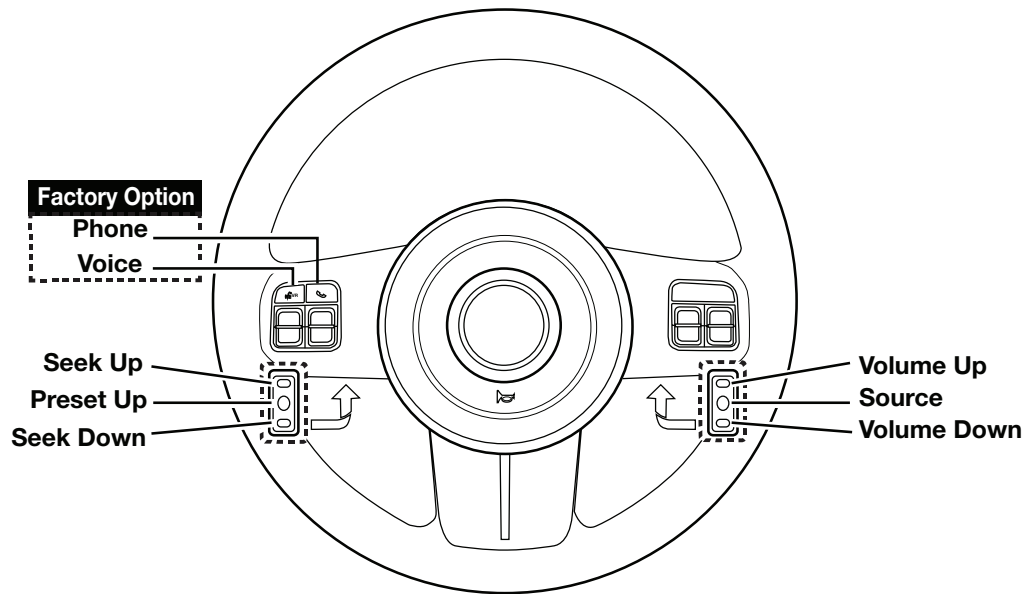

Button	Press Once	Press and Hold
Volume Up	Volume +	None
Volume Down	Volume -	None
Seek Up	Track +	Answer Call
Seek Down	Track -	Hang Up & Reject Call
Source	Source	Band
Next Preset	Preset & Folder +	Voice or Siri
Voice	Voice or Siri	None
Phone	Answer Call	Hang Up & Reject Call

Troubleshooting Guide

Symptom		Possible Cause	Remedy
1	Headunit will not turn on	Power harness may NOT be plugged in all the way.	Push the power harness until the lock tap is clipped.
		No power to the unit.	Check for bent pins on the main harness to the OEM connector.
2	Cannot enter SETTINGS MENU	Vehicle is in motion or parking brake is not engaged.	With vehicle on (P)PARK, engage the parking brake. Release the parking brake and engage the parking brake a second time.
3	iPhone is not recognized when connected to the USB cable.	Loose or disconnected USB cable.	Check the USB connection behind the headunit.
		Non-compatible cable	Use the cable supplied with the iPhone
		Dirty charging port on phone	Clean charging port
4	While on a phone call recipient complains about distorted sound.	Microphone level may be too high.	Lower the microphone level.
5	Sound mutes when vehicle is shift to reverse.	Mute on reverse is turned on in the SOUND menu.	Select Mute on reverse off.