

Jeep Wrangler

X109-WRA 9" Restyle

In-Dash System

Installation Manual

- Model: Wrangler
- Model Year: 2011-UP

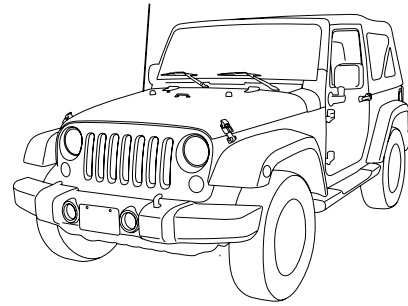

Jeep	Model	Year
	Wrangler	2011 - UP

* The specified vehicles have been tested and have met compatibility specs at the time of testing. Compatibility is not guaranteed if the manufacturer has made production changes to the listed vehicles above.

⚠ Warning: Before you begin wiring, remove the ground wire from the negative terminal of the battery. Failing to do so can lead to electric shock, injury or damage to equipment.



Introduction

- Design and specifications are subject to change without notice for improvement.





To Ensure Safe Use, Always Follow These Precautions

- The installation of this product requires specialized skills and experience. We recommend that you have the product installed by an Alpine authorized dealer.
- Before you use this product, be sure to carefully read this installation manual and the separate user's manual so that you can use the product correctly. Alpine Electronics bears no responsibility for problems that arise as a result of failure to follow the instructions in the manuals.
- This manual includes a number of symbols that are intended to help you use the product safely, to prevent harm to you and others, and to protect against damage to property. These symbols and their meanings are listed below. Make sure you fully understand these symbols before you begin reading the main text.

Explanations of Injury and Damage That May Result from Incorrect Use

 Warning	Ignoring the content marked by this indication and using the product incorrectly is expected to lead to death or serious injury.
 Caution	Ignoring the content marked by this indication and using the product incorrectly is only expected to lead to injury or property damage.

Types of Precautions

 Forbidden	Indicates actions that are forbidden (must not be performed)	 Mandatory	Indicates actions that are mandatory (must be performed)
 Forbidden	Indicates that disassembly is forbidden.		Marks content that should receive your full attention.

 **Warning**

Do not disassemble or modify the product. Doing so could lead to an accident, fire, or electric shock.



Forbidden

Store screws and other small objects where small children cannot reach them. If one of these small objects is swallowed, consult with a doctor immediately.



When replacing fuses, be sure to use fuses with the specified current rating. Failing to do so could lead to an accident or fire.



Forbidden



Mandatory

Only connect the product to a 12 VDC negative ground car. Failing to do so could lead to an accident or fire.



Mandatory

Before you begin wiring, remove the ground wire from the negative terminal of the battery. Failing to do so could lead to electric shock or injury.



Do not cut the insulation on a cord and take power from another device. Doing so could lead to fire or electric shock.



Forbidden

Do not install the product in a location where it will obstruct the driver's forward view; interfere with the operation of the steering wheel, gearshift, or the like; or pose a threat to passengers. Doing so could lead to an accident or injury.



Forbidden

When making a hole in the vehicle body, be careful to avoid damaging pipes, the fuel tank, electrical wiring, and the like. This kind of damage could lead to an accident or fire.



When installing and grounding the product, do not use any of the bolts or nuts of the steering wheel, brakes, fuel tank, or the like. Doing so could make the brakes stop working or lead to fire.



Forbidden

Do not install the product near the passenger-side airbag. Doing so could interfere with the operation of the airbag and lead to an accident or injury.



Forbidden

Bundle cords so that they don't interfere with driving. Wrapping cords around the steering wheel, gearshift, brake pedal, or the like, could lead to an accident or damage equipment.



 **Caution**

Connect the product properly according to the instructions. Failing to do so could lead to fire or an accident.



Forbidden

Do not sandwich cords between the seat railing or allow them to touch protrusions. Resulting breaks or shorts could lead to electric shock or fire.



Do not block vents or heat sinks. Doing so could lead to fire or damage equipment.



Use the accessories according to the instructions, and attach them securely. Failing to do so could lead to an accident or damage equipment.



Forbidden

Do not install the product where it may be exposed to water or in a place with high levels of humidity or dust. Doing so could lead to fire or damage equipment.









Forbidden

The installation and wiring of this product requires specialized skills and experience. Have the product installed by an Alpine authorized dealer.



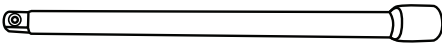
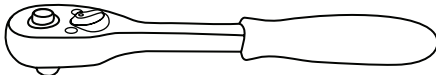
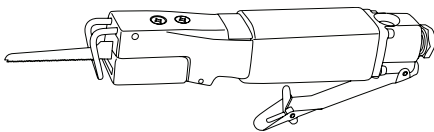



Tools Required

Panel Removing Tool	7mm Sockets	#2 Phillips Screwdriver
		
10mm Sockets	Extension	Ratchet
		
	Air Saw	Wire Cutters
		

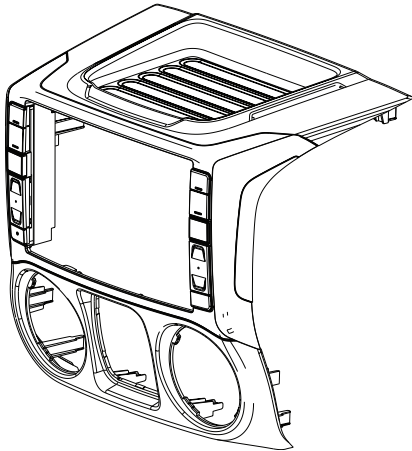

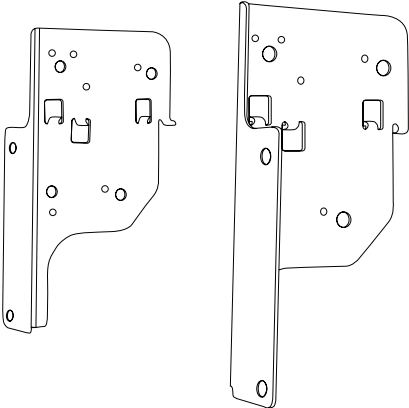
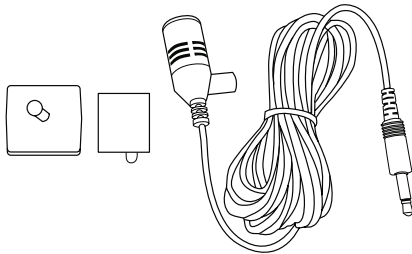

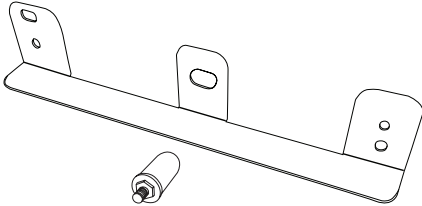
Accessory List

Installation Kit Parts (G-KTX-X109D-WRA)



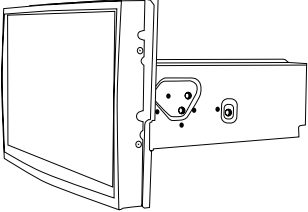
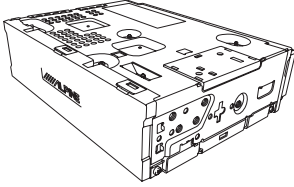
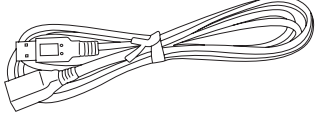
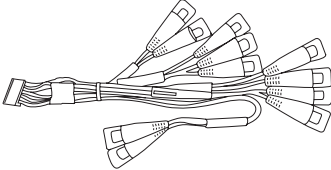
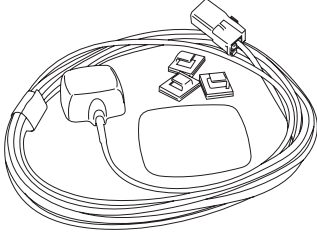

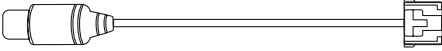
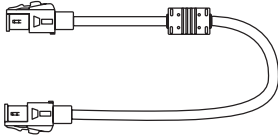
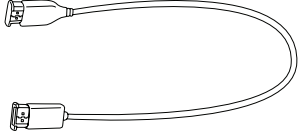
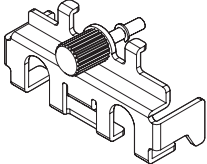
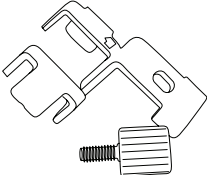
X109-WRA Radio Dash Bezel	Key Harness	Side Mounting Brackets
		
Microphone	GPS Antenna Bracket	Rear Support Bracket
		

Accessory List

Head Unit Box Parts (X109D)

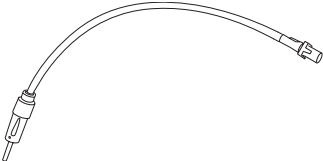
<p>X109D DVD/Display Unit</p> 	<p>X109D Source Unit</p> 	<p>USB Extension Cable</p> 
<p>AUX/Pre Out Harness</p> 	<p>GPS Antenna</p> 	<p>Documents</p>  <p>Alpine Registration Card OM QR Card</p> <p>QRG Navigation</p>
<p>Direct Camera Adapter</p> 	<p>Display Cable</p> 	<p>HDMI Cable</p> 
<p>Source Unit HDMI Bracket</p> 	<p>DVD/Display HDMI Bracket</p> 	<p>(8) 8mm Screws</p> 

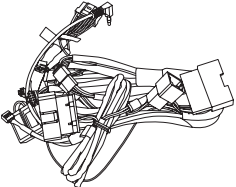
iDatalink Maestro Box Parts (ALP-MRR2/ALP-HRN-WRA2)

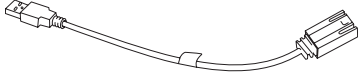
<p>Maestro Flashing Cable</p> 	<p>Antenna Adapter</p> 	<p>iDatalink Maestro Module</p> 
<p>Main Harness</p> 	<p>SAT Radio Antenna Adapter</p> 	<p>OEM USB Adapter</p> 

Component Locations

! IMPORTANT: Follow the recommended component location shown below. Failure to do so, will result in poor GPS performance.

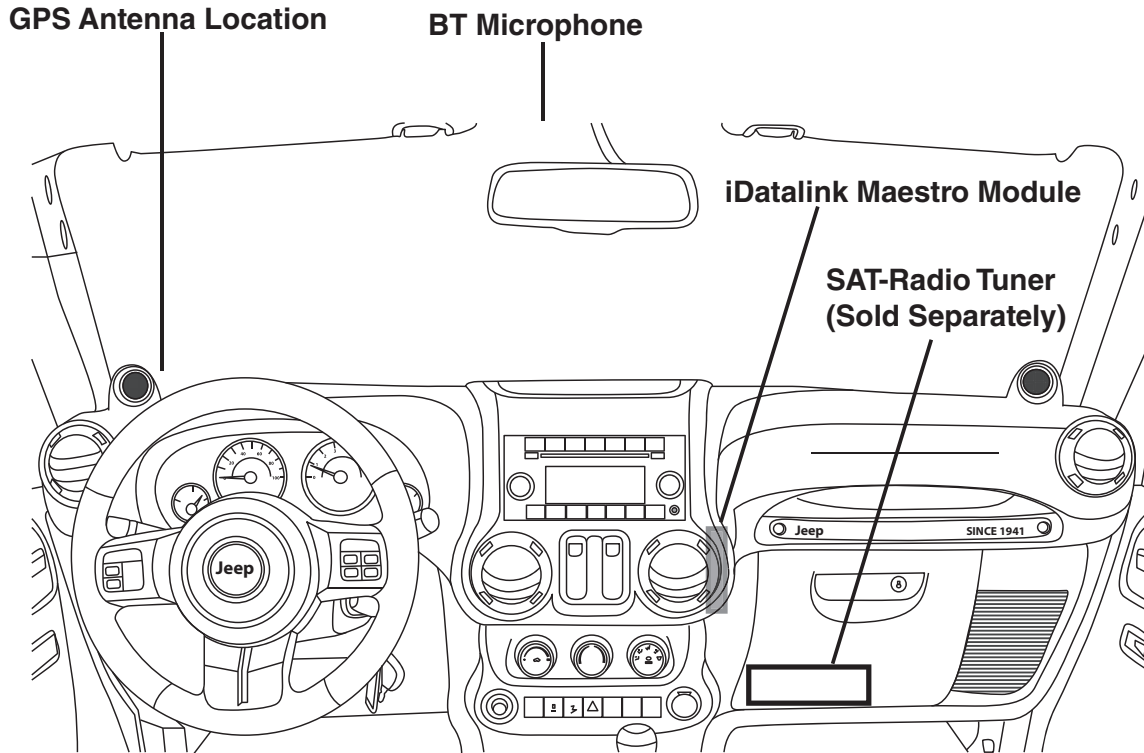

GPS Antenna Installation

! IMPORTANT: Follow the GPS antenna installation procedure shown below. Failure to do so will result in poor GPS performance.

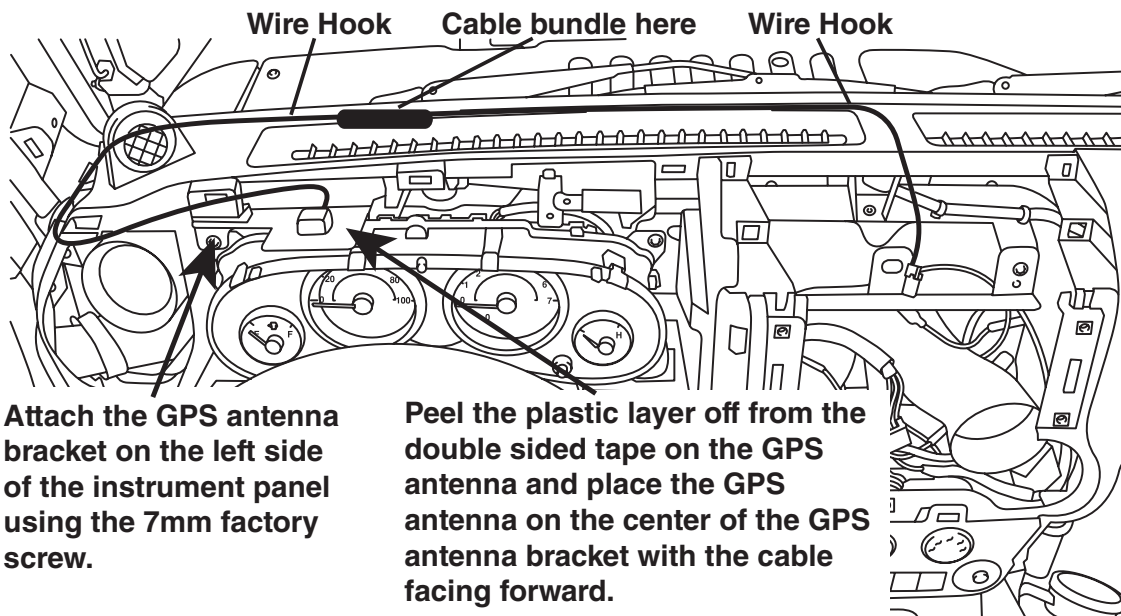

Attach the GPS antenna bracket on the left side of the instrument panel using the 7mm factory screw.

Peel the plastic layer off from the double sided tape on the GPS antenna and place the GPS antenna on the center of the GPS antenna bracket with the cable facing forward.

Factory Unit Disassembly Process

- 1 Remove the rubber cover from the top center storage area and extract (1) 7mm screw.

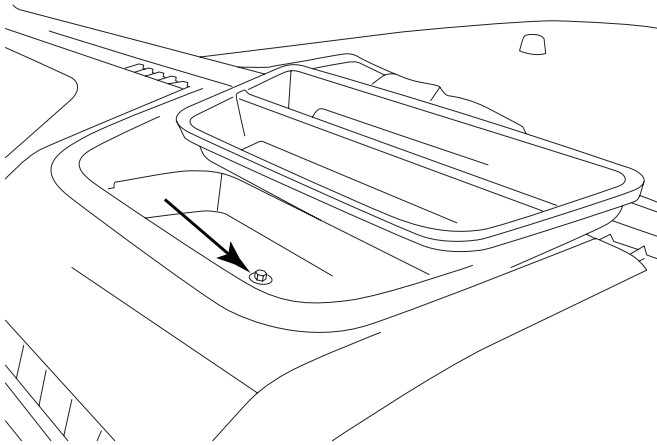

- 2 Remove the knee cover panel and extract (2) 7mm screws located to the right and left sides of the steering wheel column.



Left side of steering wheel column.

Right side of steering wheel column.

- 3 Remove the window switch pod using a panel removing tool and extract (1) 7mm screw.

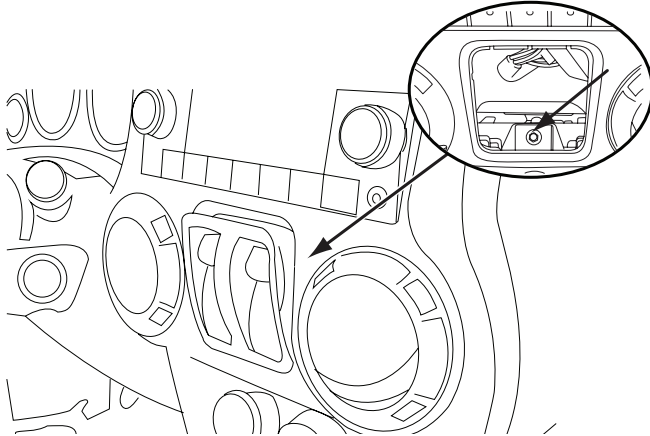

- 4 Remove the dash panel.

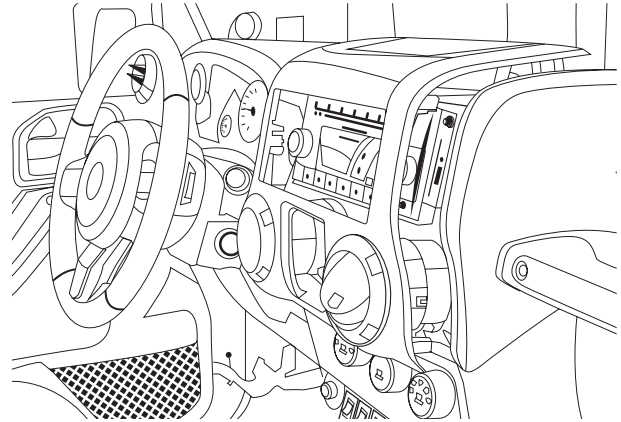

- 5 Extract (4) 7 mm screws and remove the factory radio.

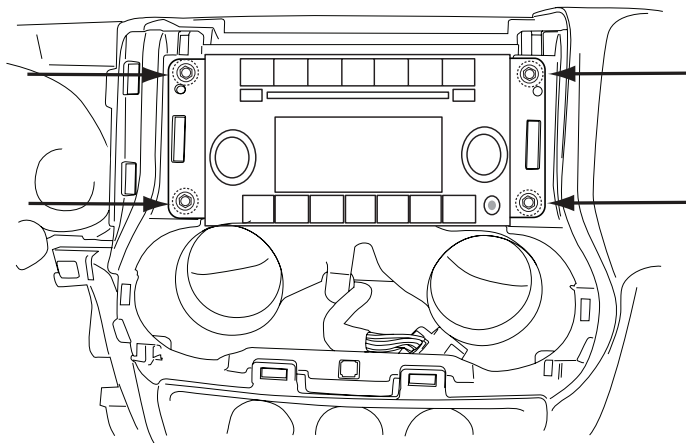

- 6 Extract (2) 7 mm screws from the factory radio bracket and remove it.

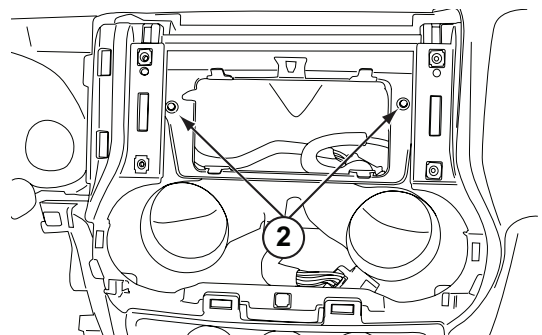

Programming the iDatalink Maestro Module

1 INSTALL THE WEBLINK PLUG-IN

Go to: idatalinkmaestro.com/plugin and follow the installation steps.

Review the System Requirements before installing.

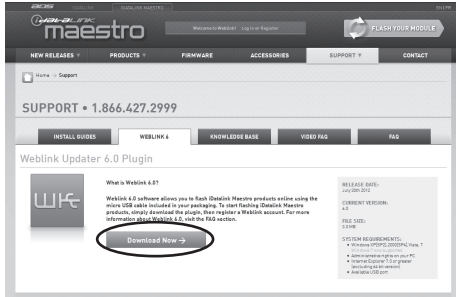

If the plugin is already installed, the caution, “The plugin is already installed” appears. Please skip to step 2.

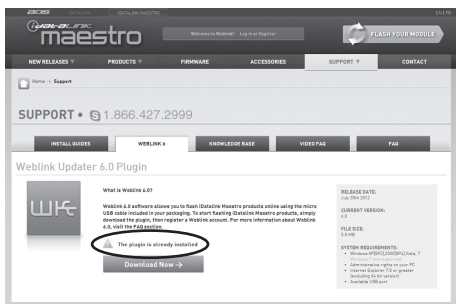

3 CONNECT YOUR MAESTRO MODULE

Use the included USB cable to connect your Maestro module to your PC.

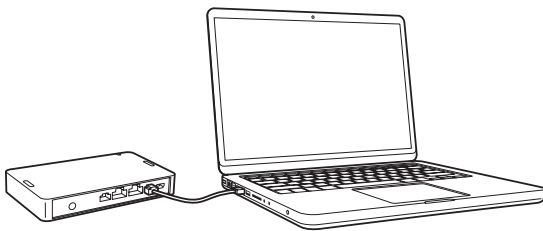

5 PROGRAM YOUR MODULE

Follow the programming steps for your vehicle.



2 REGISTER A WEBLINK ACCOUNT

Go to: idatalinkmaestro.com/register and complete the registration process.

A confirmation email will be sent to you requiring validation.

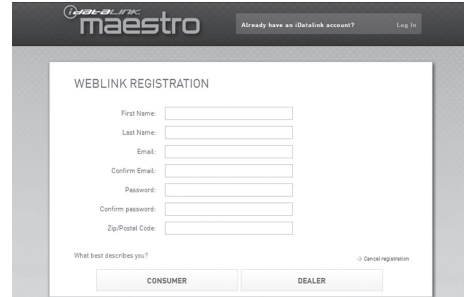

For existing customers, click log in.



4 LOG INTO WEBLINK

Go to: idatalinkmaestro.com/login. Enter your username and password, then click OK.



6 Once Programming is complete “FLASHING COMPLETED!” will be displayed.

Proceed to the next page to complete installation.

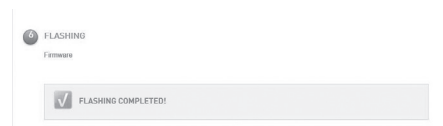

Installation Instructions

- 1 The factory dash panel needs to be trimmed to allow the new X109-WRA bezel to fit into place. Remove the highlighted area by cutting along the dashed line.

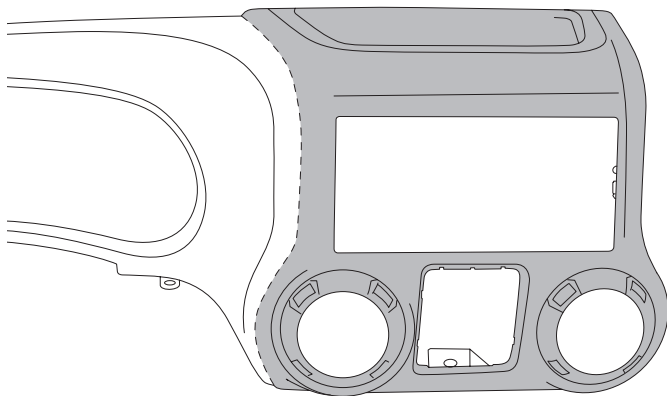

- 2 Remove the vents from the radio section on the OEM dash panel by pressing down on the lock tab and turning right. Mount vents on to the X109-WRA bezel.

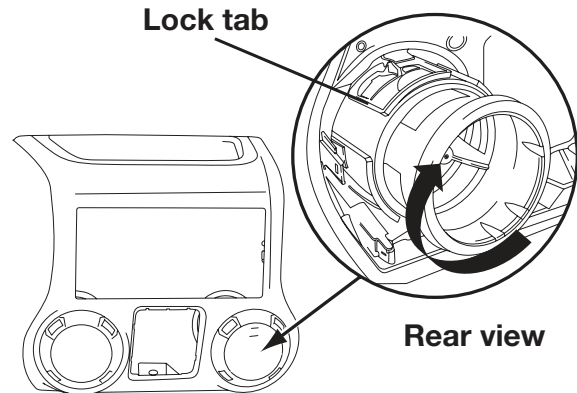

- 3 Use a cutting tool to trim the highlighted area shown below.

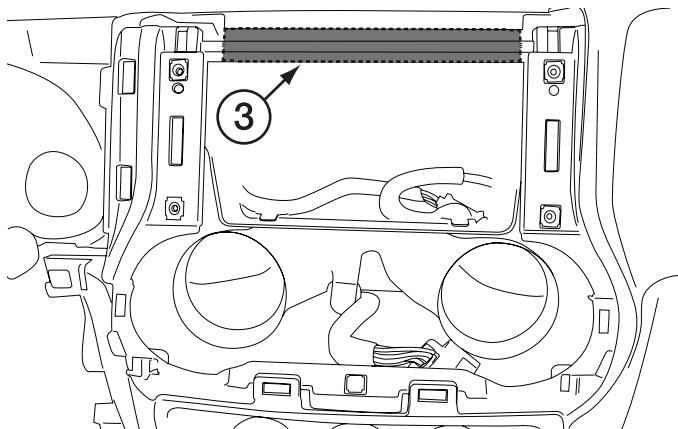

- 4 Mount the microphone as illustrated and run the cable to the radio cavity.

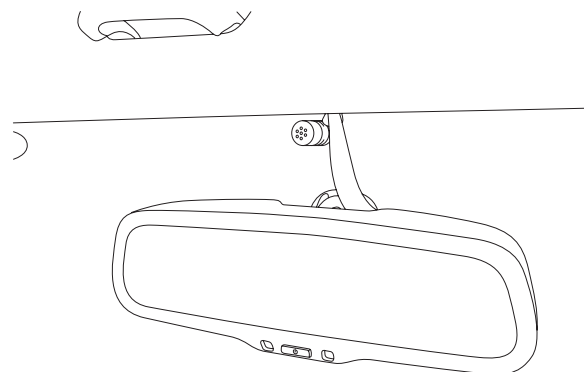

- 5 Plug the OBDII connector on to the OBDII port below the driver side dash and run the extension to the radio cavity.

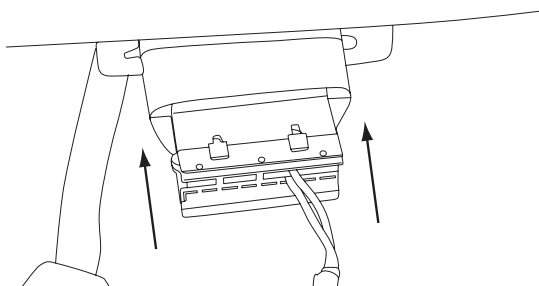

- 6 Attach the Maestro to the main harness.

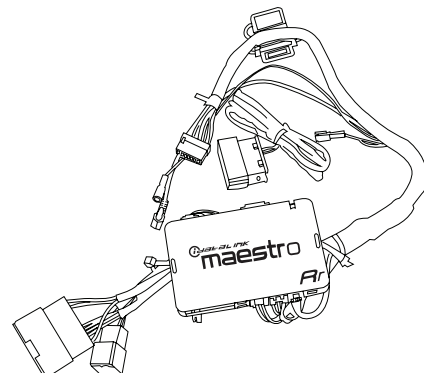

Mounting Brackets

! IMPORTANT: During the research and development of this product it was discovered that mounting tolerance may vary from the vehicle's trim level to year built. We have added a 1mm tolerance to the mounting brackets to compensate for such variance in mounting tolerance. Use the guides below as reference if there are any required adjustments.

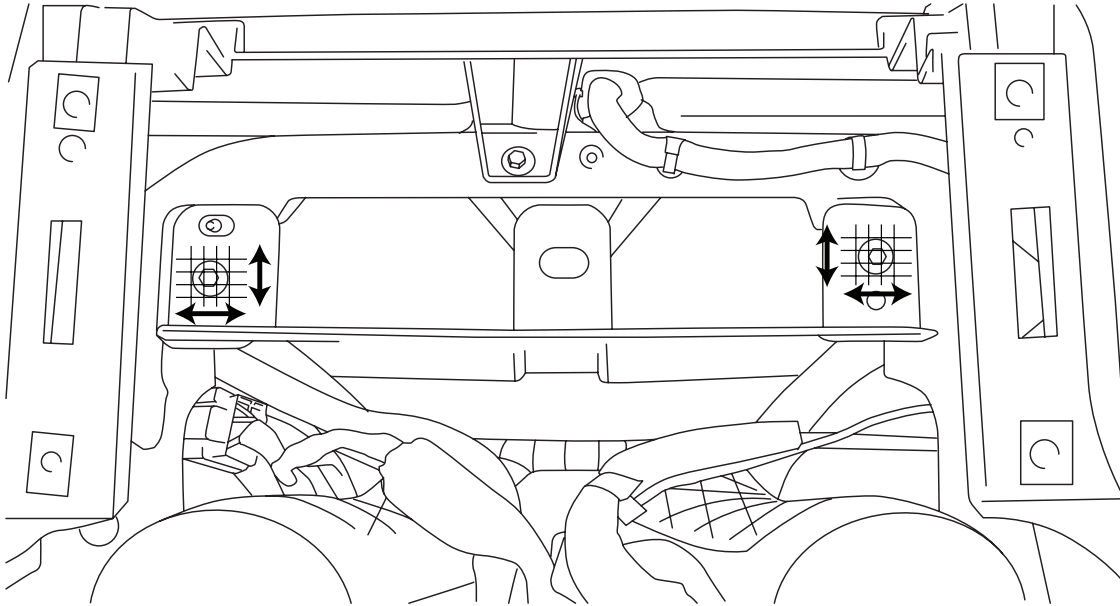

Adjust the rear bracket as needed when the top or bottom is protruding or not flushed.

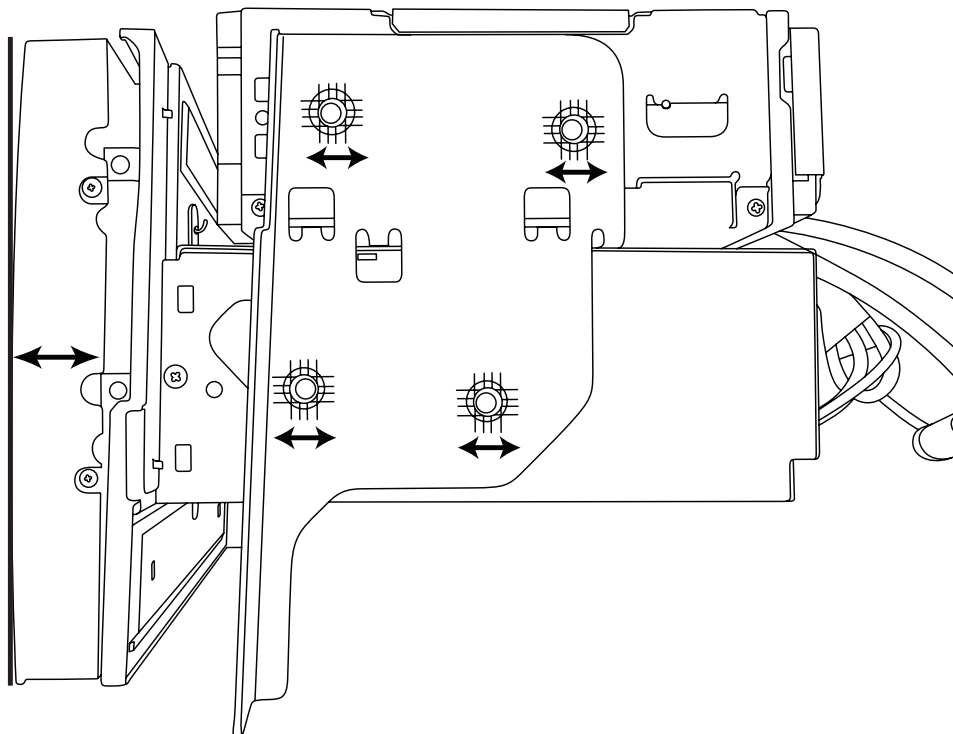

Adjust the side brackets as needed when either side is protruding or not flushed.

Installation Instructions

- 1** Attach the modified panel using the factory screws.

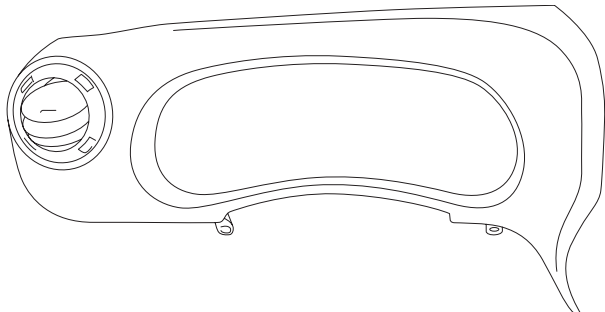

- 2** Position X109D source unit on top of X109 DVD/Display unit as shown, and attach the mounting brackets using the provided (8) 8mm screws and rear support rubber cap screw.

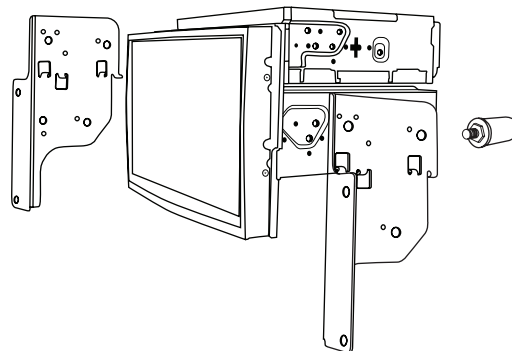

- 3** Attach the rear support bracket using (2) 7mm factory screws.

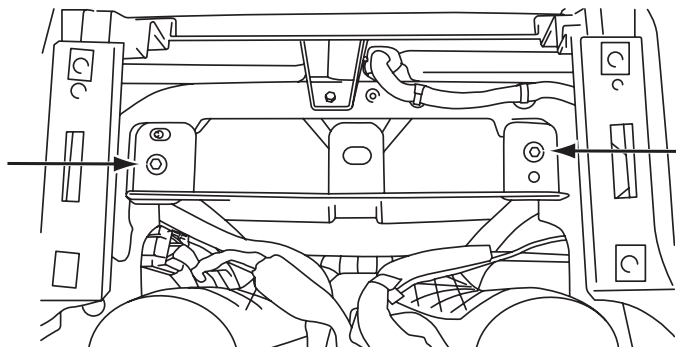

- 4** Route the USB extension cable to the glove box, connect the main harness and other adapters to the factory harness and secure them.

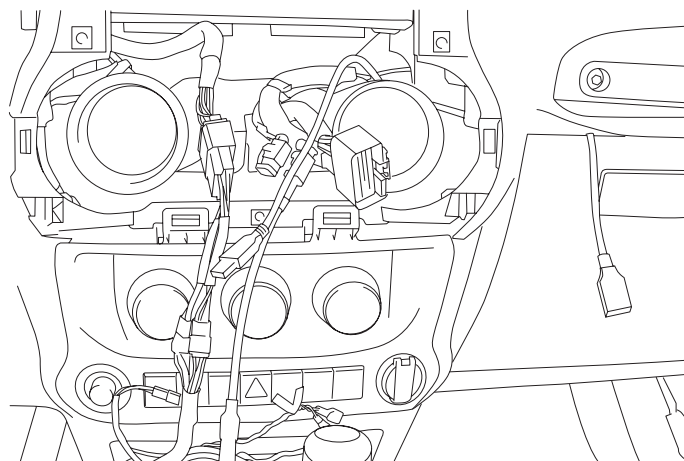

- 5** Route the key harness through the top-left side of the X109D source unit. Mount the X109D source unit using (4) 7mm factory screws.

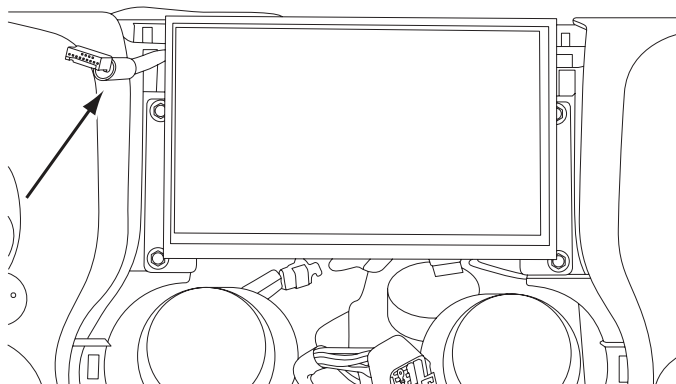

- 6** Connect the radio bezel and snap it into place.

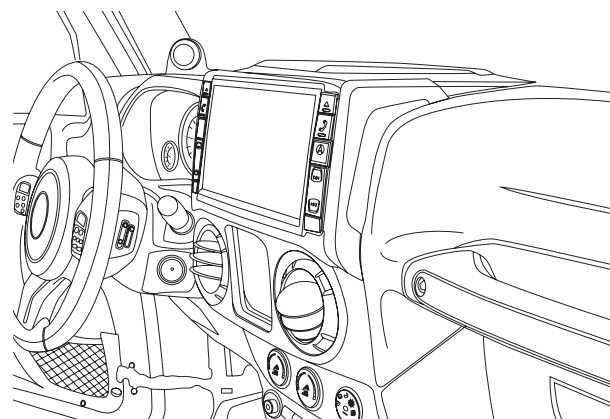

Exploded-View Diagram

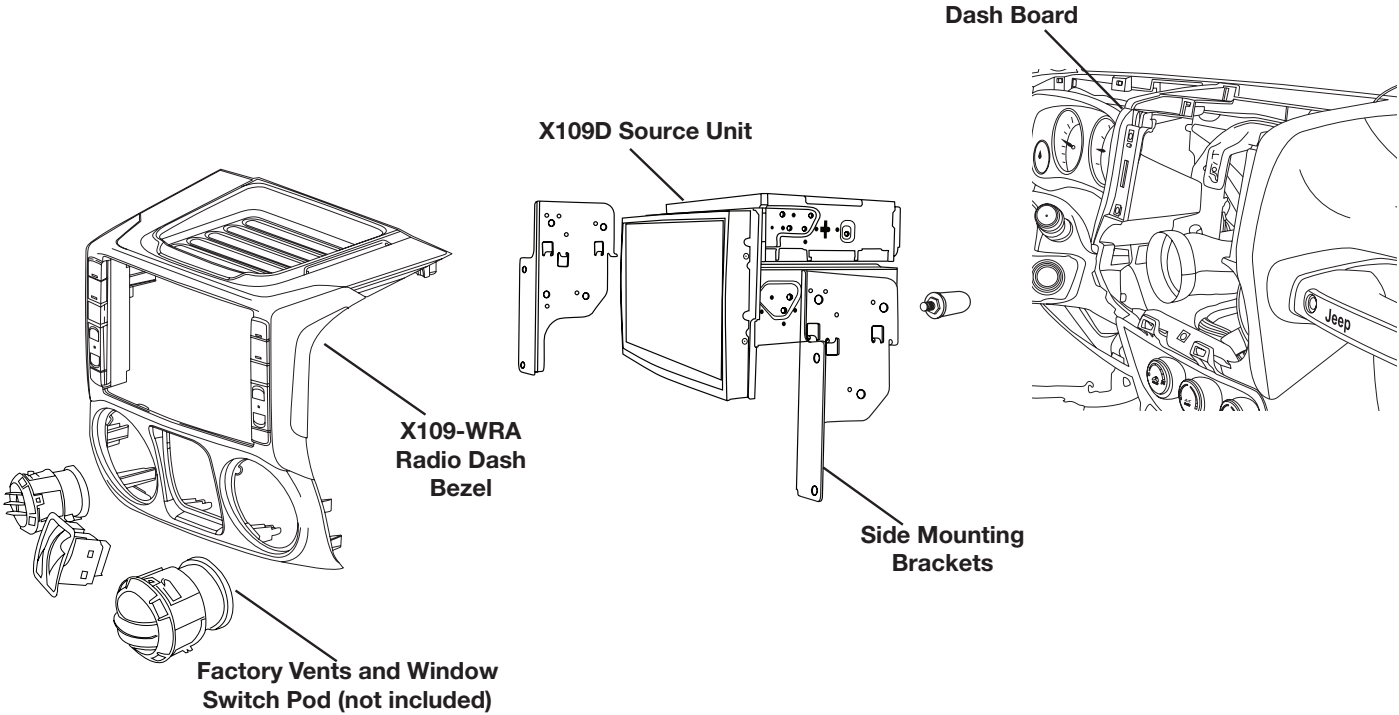

Bezel Wiring Diagram

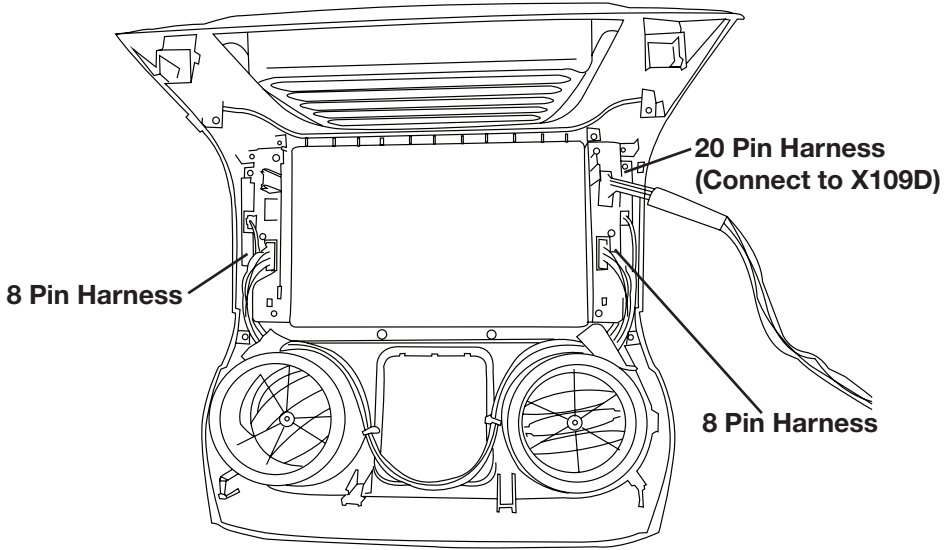

X109-WRA Wiring Diagram

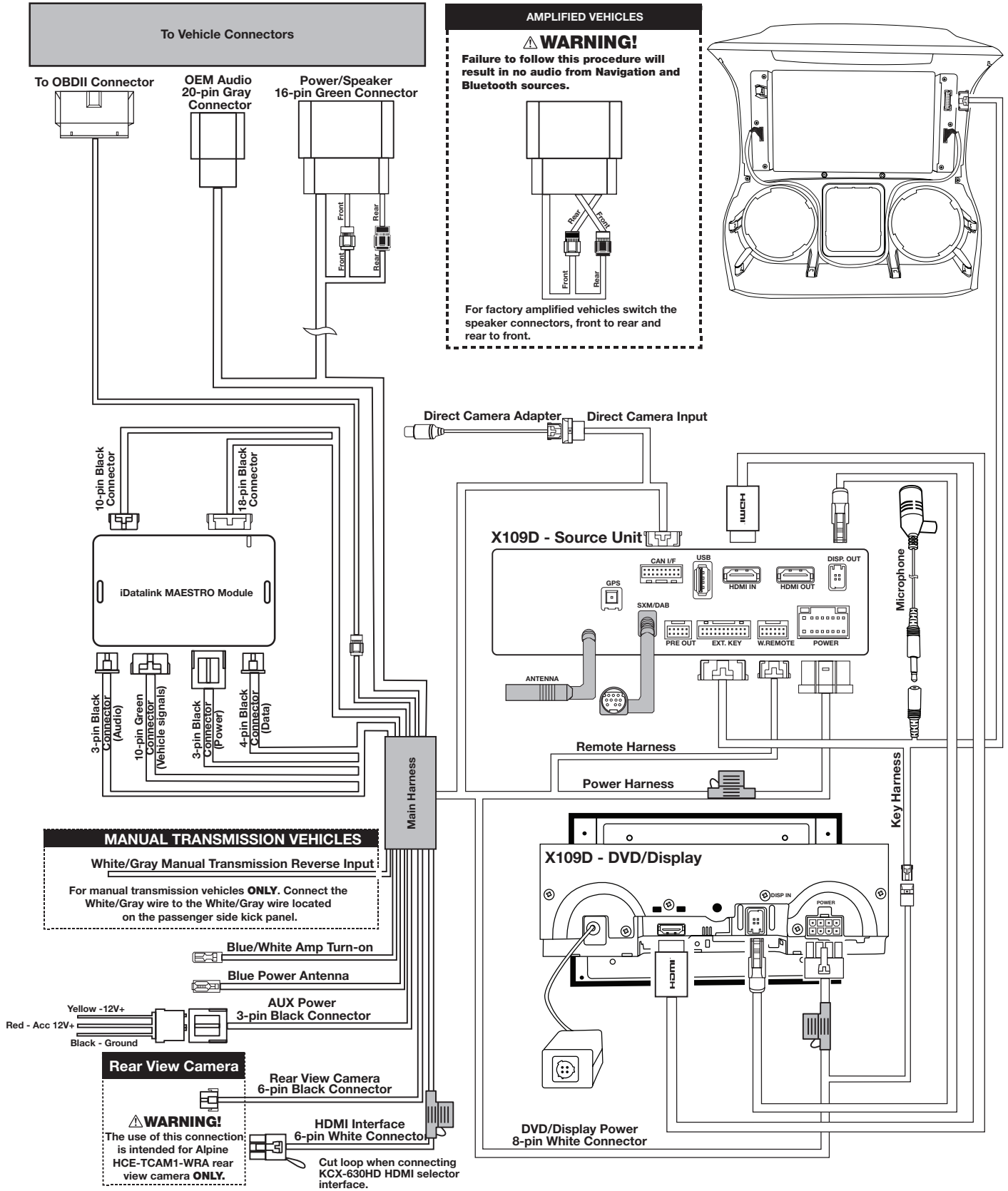

X109-WRA With Optional HDMI Interface Wiring Diagram

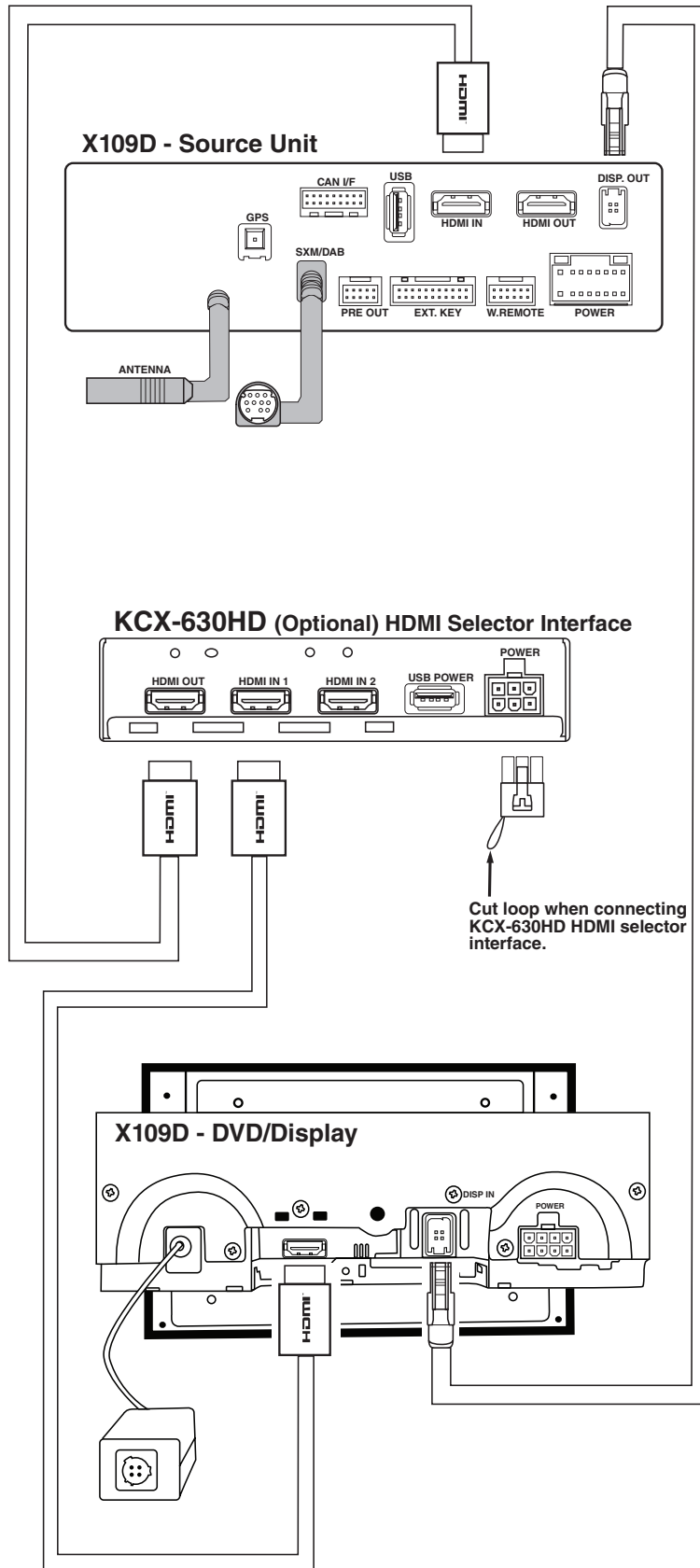

Set Up Guide

- 1 Turn the vehicle's Ignition switch to ACC.
- 2 Turn ON the X109-WRA by pressing any key.
- 3 Select the user language and press OK.
- 4 Press and release the parking brake twice.
- 5 If a camera is present, turn it ON in the system menu. (MENU/SETUP/SYSTEM/CAMERA/CAMERA SELECT)
- 6 AUDIO MUTE ON REVERSE- By default, when the vehicle is shifted into reverse the AUDIO will MUTE. If this feature is not desired turn it off in the AUDIO MENU (MENU/SETUP/SOUND/MUTE WHILE BACKING UP)
- 7 Set the DVD player. (MENU/SETUP/SOURCE/HDMI).
- 8 When the KCX-630HD (HDMI SELECTOR) is present be sure to turn it ON in the SETUP MENU. (MENU/SYSTEM/EXTERNAL ACCESSORIES/HDMI SELECTOR)
- 9 When the KAC-001 (External Accessory Control Module) is present be sure to turn it ON in the SETUP MENU. (MENU/SYSTEM/EXTERNAL ACCESSORIES/EXTERNAL ACCESSORY CTRLR)
- 10 Vehicle information- Set the desired gauge information. (MENU/VEHICLE INFO/GAUGES/CAR SETTINGS)

Troubleshooting Guide

Symptom		Possible Cause	Remedy
1	iDatalink website says serial number is invalid.	Serial number may not be in iDatalink database.	Call ADS at 1-866-427-2999 and verify.
2	Headunit will not turn on.	Incorrect serial number was used when flashing maestro.	Flash Maestro with correct serial number.
		4 pin Maestro data cable is disconnected or damaged.	Check for proper connection or disconnected pins.
		Monitor, key-harness or main harness are not connected.	Check for proper connection or disconnected pins.
3	Cannot enter SETTINGS MENU.	Vehicle is in motion or parking brake is not engaged.	With vehicle on (P)PARK, engage the parking brake, release the parking brake and engage the parking brake a second time.
4	Cannot control the DVD Player properly.	DVD has not been set on the SETUP menu.	Ensure DVD is ON in HDMI SETUP menu.
		HDMI box has not been set on the SETUP menu.	Ensure DVD is ON in HDMI SETUP menu and remote loop was cut on the wire harness.
5	Sound mutes when vehicle is shift to reverse.	Mute on reverse is turned on in the SOUND menu.	Select Mute on reverse off.
6	On Nav screen the vehicle is out of place.	Poor GPS signal.	Ensure the recommended GPS antenna route was used. See page 6.