

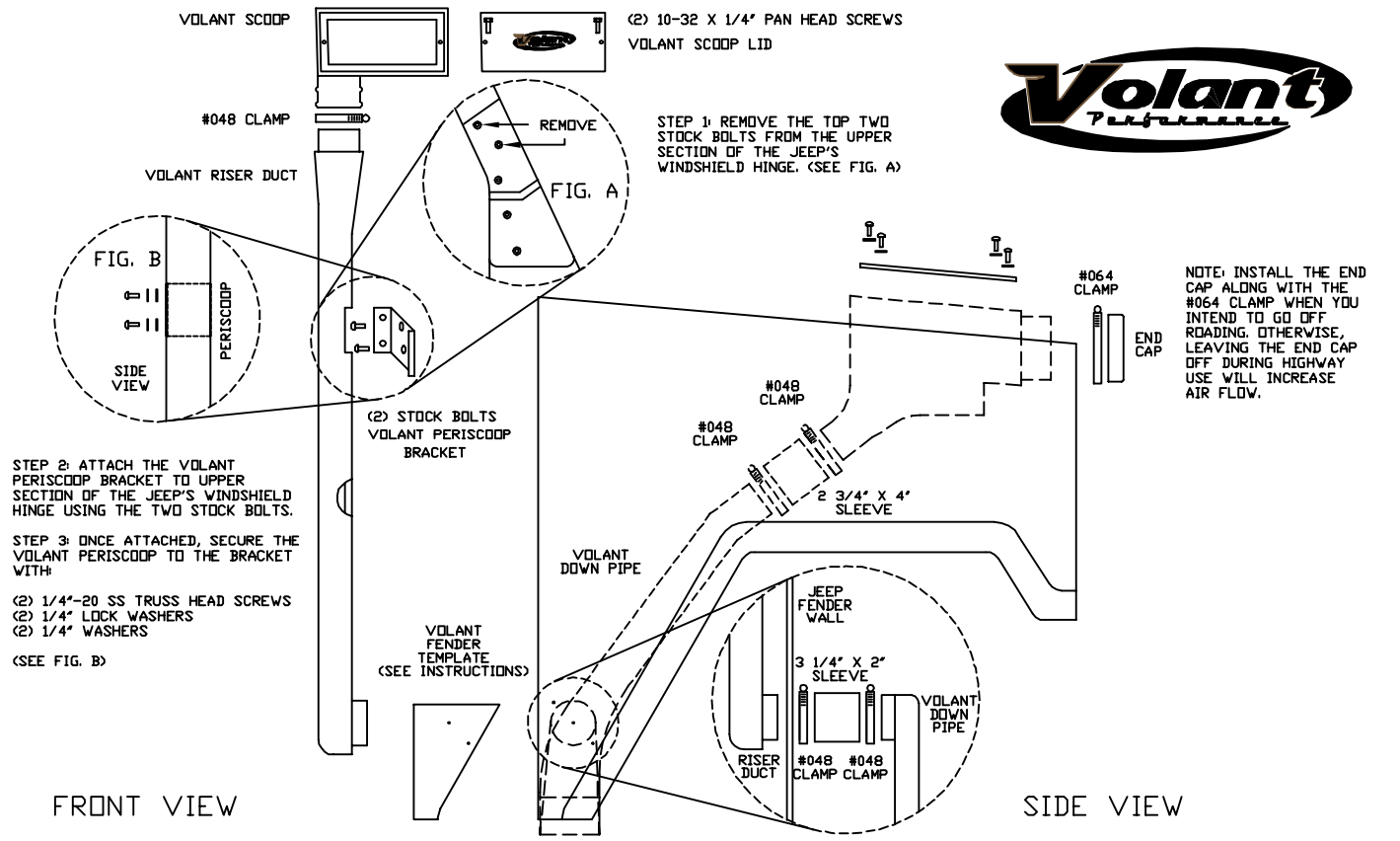

8759 Lion Street
 Rancho Cucamonga, CA 91730
 (909) 476-7225 TECH SUPPORT
 (909) 476-1491 FAX
 www.volantperformance.com

INSTALLATION INSTRUCTIONS
PART NO.
37640

TOOLS NEEDED FOR INSTALL:		37640 PARTS LIST			
1. FLATHEAD SCREWDRIVER		1	VOLANT SCOOP	1	3 1/4" X 2" SLEEVE
2. 10 MM SOCKET		1	VOLANT SCOOP LID	2	10-32 X 1/4" PAN HEAD SCREWS
3. RATCHET		1	VOLANT RISER DUCT	2	1/4"-20 SS TRUSS HEAD SCREWS
4. 10/32 SOCKET		1	VOLANT DOWN PIPE	2	1/4" LOCK WASHERS
		5	#048 CLAMPS	2	1/4" WASHERS
		1	#064 CLAMP	1	VOLANT PERISCOOP BRACKET
		1	2 3/4" X 4" SLEEVE	1	VOLANT FENDER TEMPLATE



APPLICATION GUIDE PART NO. 37640				RECOMMENDED SERVICE PART NUMBERS		READ INSTRUCTIONS THOROUGHLY BEFORE DISASSEMBLING. DO NOT SKIP ANY STEPS. ANY QUESTIONS ON A VOLANT KIT MAY BE REFERRED TO OUR TECH SUPPORT LINE AT (909) 476-7225 OR VISIT OUR WEBSITE AT WWW.VOLANTPERFORMANCE.COM
MY 1997-2006	MAKE JEEP	MODEL WRANGLER	ENG. 4.0L	VOLANT REPLACEMENT FILTER	5113	
				AIR FILTER CLEANER KIT	5100	

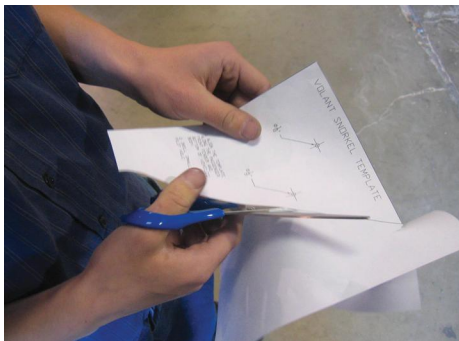

1. Cut out the template along the dotted line with a pair of scissors.



2. Align template along the side base of the jeeps passenger fender. Tape the template to the fender.



3. Once the template is lined up and taped to the fender, drill two 1/8" pilot holes as noted on the template.



4. Remove the template from the fender. Drill a 3" hole with a hole saw on the top 1/8" pilot hole and a 3/8" hole with a drill bit on the lower pilot hole.



5. Remove the two top counter sink bolts from the front windshield bracket with a torx key #40 Note: In order to loosen the bolts, tap them lightly with a hammer to loosen the Loc tite.



6. Place the 3" X 3" sleeve on the small opening of the Volant down pipe and the 3/4" X 2" sleeve on the other end of the short snorkel..



7. Attach the short snorkel onto the filter box by running it from underneath the vehicle and work your way up to the filter box and align the sleeve to the 3" hole on the fender.

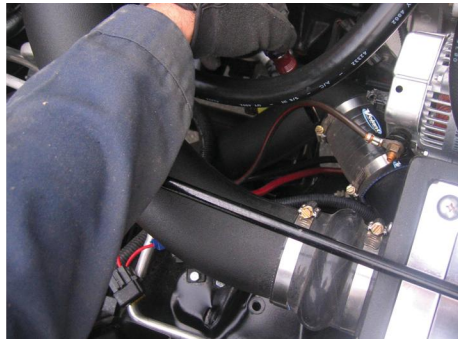

8. Clamp both ends of the 3" sleeve with two of the four #48 clamps to hold the Volant down pipe to the bottom of the filter box.



9. Bolt the Volant periscope bracket onto the windshield bracket using the stock counter sink bolts.



10. Screw the 1/4" -20 set screw using a 1/8" Allen key to the molded insert on the right side of the opening of the Volant riser duct.



11. Insert the 3" opening of the Volant riser duct into the hole on the fender and into the sleeve. Clamp both ends of the sleeve with two #48 clamps using a 5/16" nut driver. With the 1/4" washer, lock washer and nut bolt the set screw to the vehicle from the inside of the fender and tighten with a 7/16" open wrench. Note: This will need two people.

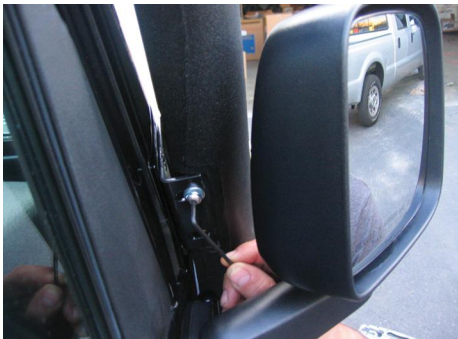

12. Mount the Volant riser duct to the bracket and bolt the Volant riser duct to the bracket using the two 1/4"-20 ss truss head screws and tighten with a 5/32" Allen key.



13. Once the Volant Periscope is mounted and bolted on the vehicle place the Volant Scoop to the top of the Volant riser duct and clamp it down with a 5/16" nut driver key.

WARNING: OVER TIGHTENING HARDWARE MAY ALTAR THE INTEGRITY OF THE VOLANT AIR INTAKE SYSTEM.

BEFORE ROAD TESTING

1. Start engine, leaving the transmission in park and securing the parking brake.
2. Make sure to look and listen for any unusual noises or air leaks. Repair problems if needed.
3. Once completed it will be necessary to check periodically for realignment and tightening of all connections.
4. Once all tests are completed, enjoy the performance of your new Volant Air Intake System.

CARE AND CLEANING

Check the cotton reusable filter periodically and remove any excessive dirt build-up by tapping the filter on the ground and brushing off the loosened dirt. Clean the filter by using Volant's Filter Recharger Kit. Volant's Filter Recharger Kit is designed to restore original air flow. Re-oil every 10,000 miles without cleaning to improve filtering in sand and dirt. Clean only when dirt is very excessive or 50,000 miles.



VOLANT COOL AIR INTAKES
 PART NO: 17540
 INSTALLATION INSTRUCTIONS
 WWW.VOLANT.COM
 TECH SUPPORT: (909) 481-3888

17740 PARTS LIST					
1	VOLANT FILTER BOX	1	3' X 2 1/2' REDUCER	4	1/4' RUBBER WASHERS
1	VOLANT FILTER BOX LID	1	3 1/2' X 3' HUMP HOSE	3	5/16' WASHERS
1	VOLANT AIR DUCT	3	1/4"-20 X 3/4' BOLTS	3	1/4' WASHERS
1	VOLANT ADAPTER	3	10/32" X 1/2" SCREWS	1	1/2" RUBBER GROMMET
1	RAM FILTER W/CLAMP	4	1/4"-20 TRUSS HEAD SCREWS	1	1/2" RUBBER PLUG
2	#048 CLAMPS	3	1/4' LOCK WASHERS	1	VOLANT ADAPTER GASKET
2	#056 CLAMPS	3	5/16' LOCK WASHERS		

NOTE: INSTALL AIR TEMP SENSOR ONLY ON 04-06 MODELS. USE 1/2" RUBBER PLUG IF NOT APPLICABLE.

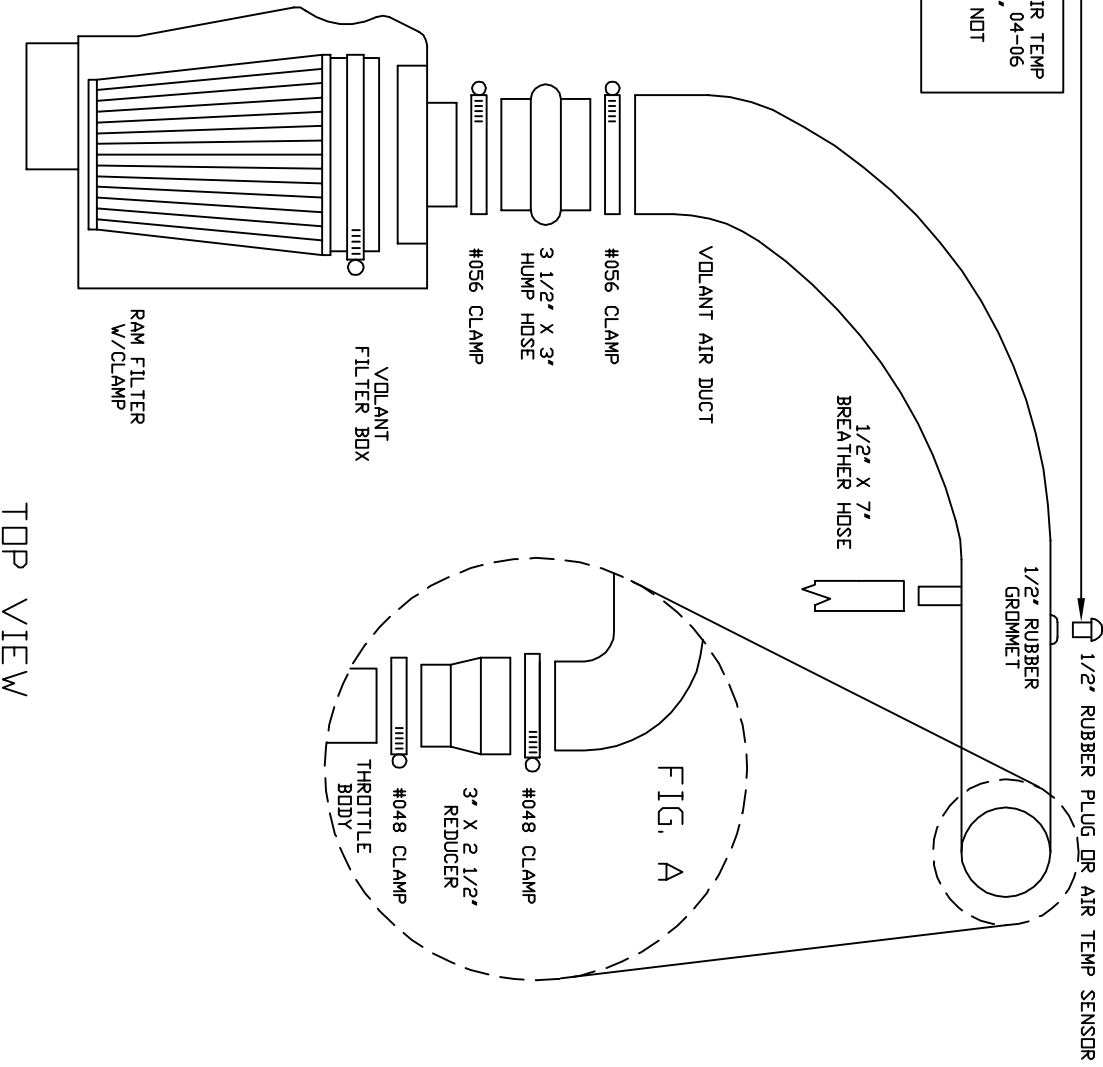
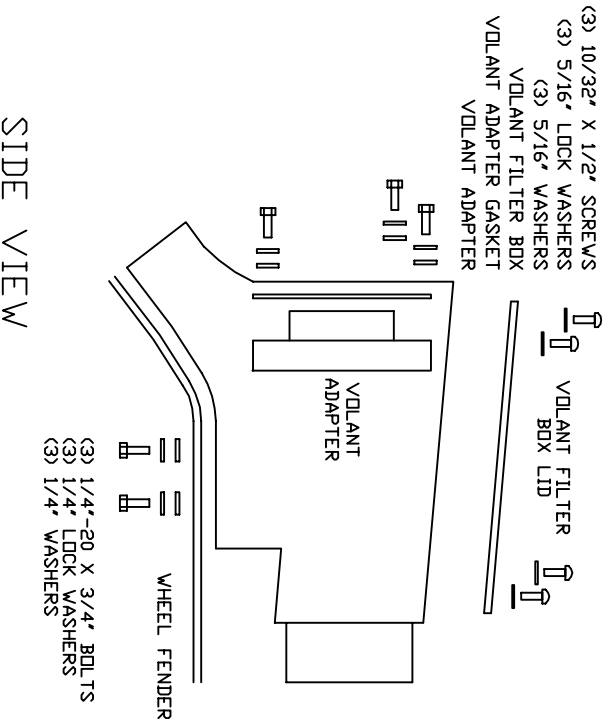

SIDE VIEW

TOP VIEW



Volant Performance
 Rancho Cucamonga, CA 91730
 (909) 481-3888 Tech Support
 (909) 476-1491 Fax
 www.volant.com

READ INSTRUCTIONS THOROUGHLY BEFORE DISASSEMBLING. DO NOT SKIP ANY STEPS. ANY QUESTIONS ON A VOLANT KIT MAY BE REFERRED TO OUR TECH SUPPORT LINE AT (909) 481-3888 OR VISIT OUR WEBSITE AT WWW.VOLANT.COM

INSTALLATION INSTRUCTIONS PART NO. 17540

Installation Instructions:

1. Disconnect the negative battery cable.
2. Remove 8 mm bolt with 13 mm socket from the support rod that attaches to the radiator core support.
3. Loosen both clamps from the stock air duct with 5/16 socket or flat head screwdriver.
4. Disconnect the stock breather hose from valve cover and stock air duct.
5. In 04-06 models, disconnect plug from air temp sensor. Loosen clamp and remove the stock air duct from the engine compartment
6. Remove the three nuts that bolt the stock air box to the passenger fender with a 10 mm socket.
7. Once the nuts are removed from the passenger fender, remove the stock air box from the engine compartment.
8. Connect the reducer onto the small opening of the Volant air duct and clamp the reducer onto the Volant duct with the #048 clamp provided.
9. Install the Volant air duct with the reducer on the engines throttle body and with the #040 clamp snug the reducer onto the throttle body.
10. Place the Volant Filter Box in preexisting location of the stock box. Attach the Volant Filter Box with the (2) ¼" bolts, (2) ¼" washers and (2) ¼" lock washers provided.
11. Fasten the Volant Filter Box onto the passenger fender with a 7/16 socket or open wrench.
12. 04-06 Remove the air temperature sensor from the stock air duct. Reinsert the sensor into the Volant ½ rubber grommet located on the back side of the duct. Reconnect the air temperature to the engines wire harness plug.
13. Connect the Volant Air Duct with 3 1/2" Hump Hose to the Volant Filter Box. Tighten the #056 clamps on both ends of the 3 ½" X 3" hump hose with a 5/16 socket or flat head screwdriver.
14. Once the Volant Air Duct is aligned with the Volant Air Box and the throttle body clamp down on the both clamps that is on the reducer.
15. Insert the Volant Filter in the Volant Air Box and clamp it down onto the Volant Filter Adapter with the clamp provided.
16. Screw down the Volant Lid onto the Volant Filter Box using a Phillips screwdriver.
17. Reinstall the support rod with the stock 8 mm bolt.
18. Connect one end of the ½" X 7" breather hose to the molded fitting on the Volant Air Duct and the other end to the valve cover.
19. Reinstall the battery cable

WARNING: OVER TIGHTENING HARDWARE MAY ALTAR THE INTEGRITY OF THE VOLANT AIR INTAKE SYSTEM.

BEFORE ROAD TESTING

1. Start engine, leaving the transmission in park and securing the parking brake.
2. Make sure to look and listen for any unusual noises or air leaks. Repair problems if needed.
3. Once completed it will be necessary to check periodically for realignment and tightening of all connections.
4. Once all tests are completed, enjoy the performance of your new Volant Air Intake System.

CARE AND CLEANING

Check the cotton reusable filter periodically and remove any excessive dirt build-up by tapping the filter on the ground and brushing off the loosened dirt. Clean the filter by using Volant's Filter Recharger Kit. Volant's Filter Recharger Kit is designed to restore original air flow. Re-oil every 10,000 miles without cleaning to improve filtering in sand and dirt. Clean only when dirt is very excessive or 50,000 miles.

RECOMMENDED SERVICE PARTS

RECOMMENDED SERVICE PARTS	PART NO.
POWERCORE FILTER UPGRADE	61513
REPLACEMENT FILTER	5120
POWERCORE PREFILTER	51920
COTTON PREFILTER	51914
SNORKEL	37640
CLEANING KIT	5100

APPLICATION GUIDE

MY	MAKE	MODEL	ENG.
00-06	JEEP	WRANGLER	4.0L

INSTALL



VOLANT SNORKEL TEMPLATE

