

HOIST-A-TOP® JL CRANK



Call toll free 1866 284 7428
langeoriginals.com copyright
lange originals 2017



Comprehensive Video Guide Instructions Available

Thank you for choosing the Lange Originals® Hoist A Top® Crank style. We have added a comprehensive video instructions. This video is available streaming on youtube at the following QR code or hyper-link. To use it on your smart-phone just scan the QR code with your favorite scanner (available on Google play or IOS markets). To use on a Computer type the web address URL into your browser bar: https://youtu.be/orz0M1kAo_8

This video is broken up into sections for easy navigation and is a step by step guide on installation of this product.

VIDEO STREAMING LINKS



https://youtu.be/orz0M1kAo_8

Safety Requirements

Please Read!

Please thoroughly read and understand these instructions before installing your Hoist-A-Top® and before lifting your top.

When installing the Hoist-A-Top® remember safety first! Make sure you use proper safety equipment when installing this product. Use gloves and eye protection. Be careful on ladders. If you are unsure about installing this product consult a professional or call us at the factory.

Cautions:

- **Make sure your garage or structure is capable of supporting the weight of your top. If there is any question about your structure's integrity, consult a professional.**
- **Before lifting your top make sure that all hardware is properly fastened to the center of your studs in your wall and ceiling. Wire clamps must be checked and tightened regularly.**
- **Do a dead weight lift to initially test your installation.**
- **Upon lifting your top for the first time and subsequent times thereafter visually and check that all hardware including but not limited to wire clamps , elevator bolts, hooks , wire cable, crank hoist, and lifting strap. Make sure all are tight and in good working order.**
- **Lange Originals is not responsible for damage or personal injury due to improper installation, custom installation that doesn't follow the instructions, or neglect to inspect equipment prior to using equipment.**

If you need help for any reason DO NOT CALL YOUR DEALER Please contact us direct at the factory. We can help with missing parts or for help with installation.

Call toll free 1-866-284-7428 or email at contact1@langeoriginals.com

HOIST A TOP[®]

PLEASE READ ALL INSTRUCTION BEFORE INSTALLATION

Parts List

Parts are listed by part number, description, and quantity. The part number may be referenced in the instructions designated by parenthesis () for your convenience. Parts are updated periodically and may vary in color or shape.

014-920 Hoist-A-Top Crank for JL Jeeps

Part Number	Description	Qty
Frame		
HAT-101	Support Arms	3
HAT-100	"T" Section with Lifting Blade	1
HAT-018	Black Foam Holes	4
HAT-003	"J" Hooks	2
HAT-127	JL Rear Hook	1
HAT-134	Foam Square Support	1
HAT-135	Long Foam Arms (2 pcs)	1
HAT-019	Bungee Cord	2
Hardware Parts Bag-023		
HAC-028	Small Plastic End Caps	3
HAC-015	Nylon Insert Lock Nut	3
HDW-015	3/8 Wing Nut	1
HAT-050	Zinc Plated 3.5" Screws	13
HAT-125	1.5" Wood Screws	13
HAC-043	Wire Rope Clamps	6
HDW-054	3" Lag Screws	2
HAC-023	3/8 Flat Washer	2
HAT-110	Grommet Strap	2
HDW-031	Wire Thimbles	2
Crank Unit & Mounting Components		
HAC-010	Crank Unit	1
HAT-116	Single Flush Mount Pulley	2
HAT-118	Double Flush Mount Pulley	1



Installation of the crank unit

1. Remove the spool from the crank unit using the 11/16 and 9/16 socket
2. Cut one section of 2x6 to 20 inches. Mount it to your wall using at least 4 screws (at least two in each stud) aprox. 50-inches above the floor.
3. Mount your crank unit to the center of the 2x6 using the 2 3-inch lag screws and washers provided.

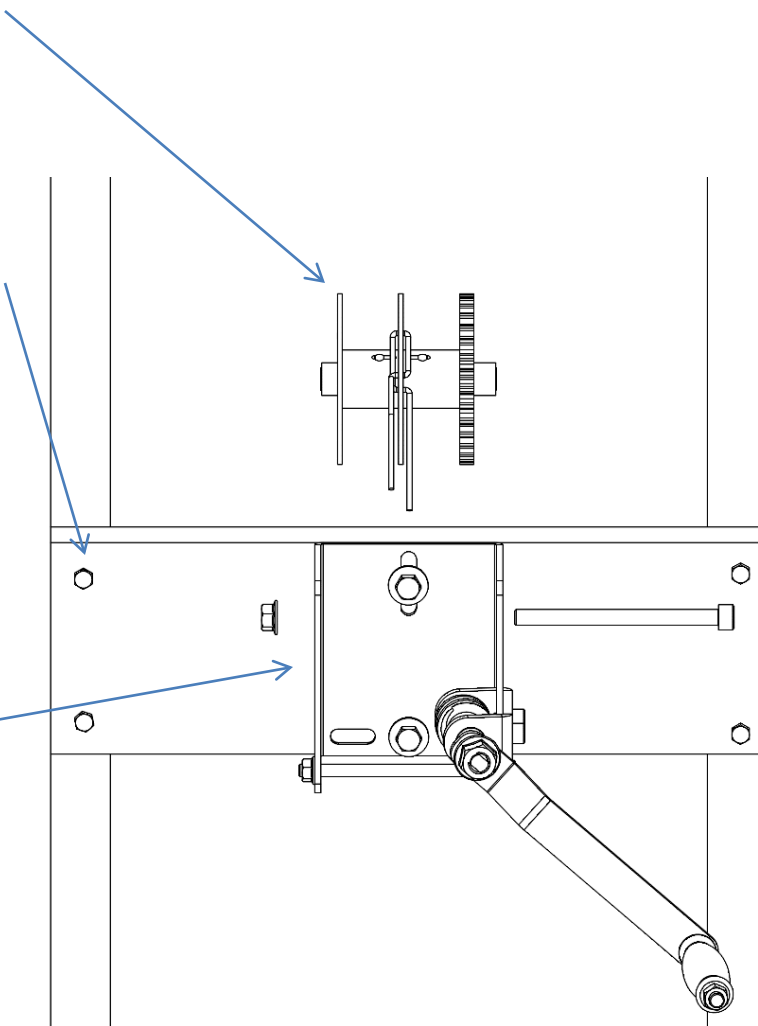

Ceiling

Parallel stud installation

Determine if your studs run perpendicular or Parallel with your garage door. If your studs run perpendicular to (or the opposite direction as your garage door).

1. With the mounting screws provided, mount the double pulley and one of the single pulleys in the center of your 2x6.
2. Mount the second single pulley $\frac{1}{2}$ inch left of center on the 2x6. This will allow the second cable to run along the ceiling without interfering with the other cable.

Hint:

It may be easier to put in the screws when the wheels are removed

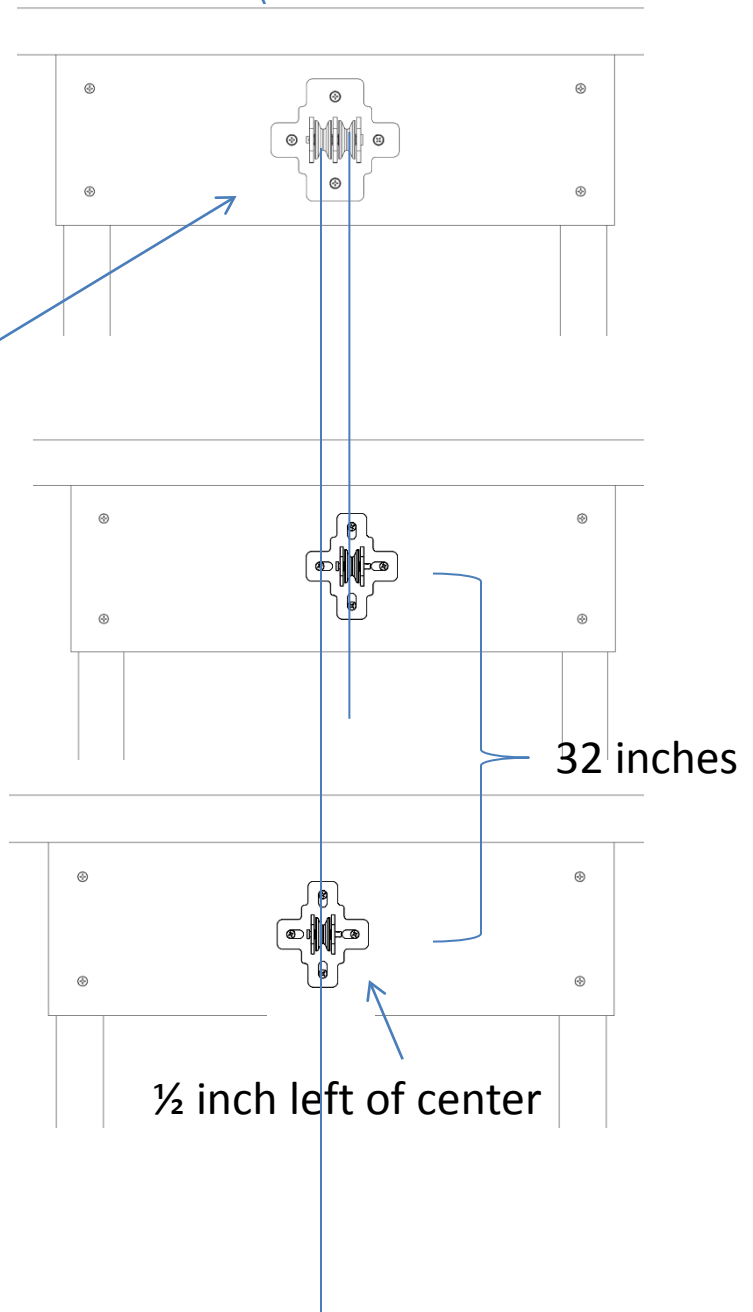

Ceiling

Perpendicular stud installation

If your beams run perpendicular to your garage door you need to run your 2x6 piece differently

1. Mount the double pulley on a 20 inch 2x6. You can mount your double pulley on the ceiling or at the top of the wall. Attach your 2x6 to three studs in line with the double pulley in the corner of the wall. The distance between the double pulley and the first single pulley can be custom to your garage.

2. Cut your 2x6 approximately 50 inches long.

3. With the provided hardware attach both single pulleys on the 2x6 32 inches from each other. Make the first pulley on center and the second pulley $\frac{1}{2}$ inch left of center. This will allow the cables to run next to each other without interference.

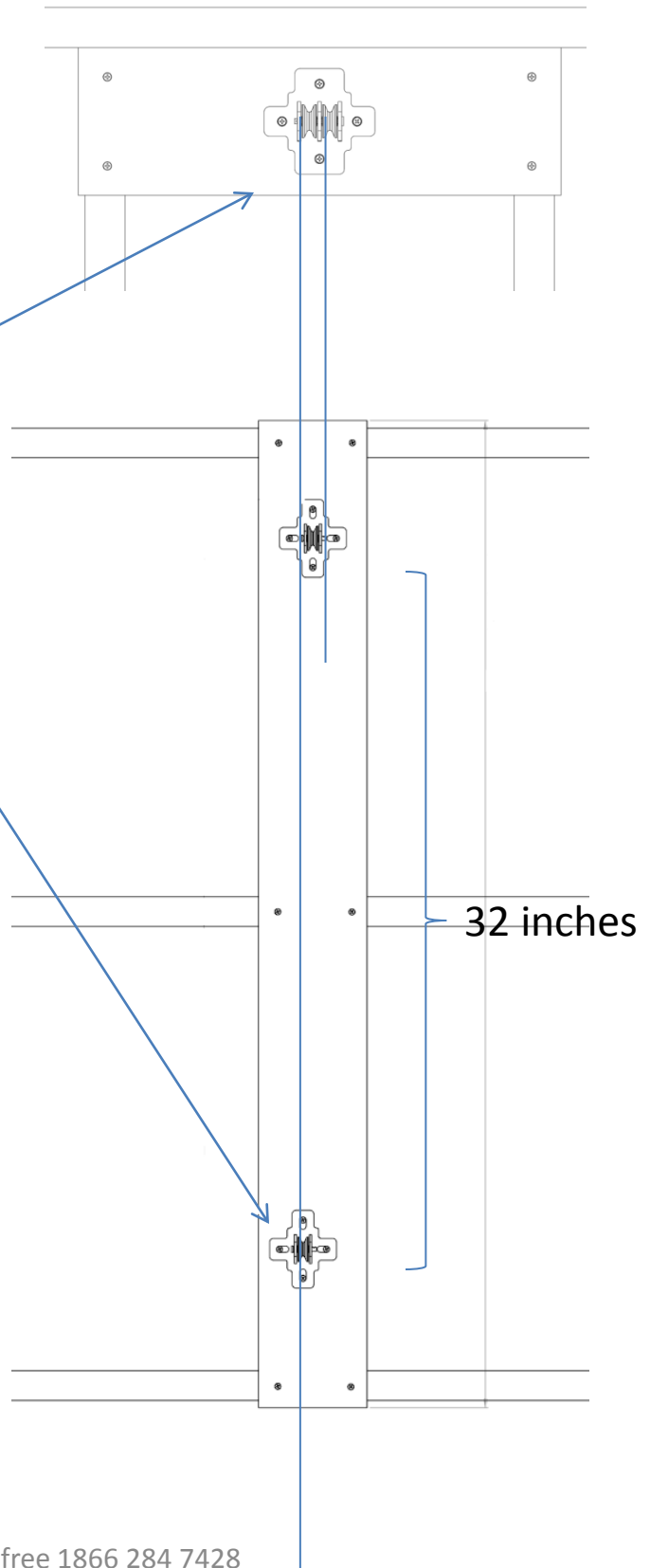

This pulley is ½ inch left of center.

This pulley can be installed on the wall or ceiling

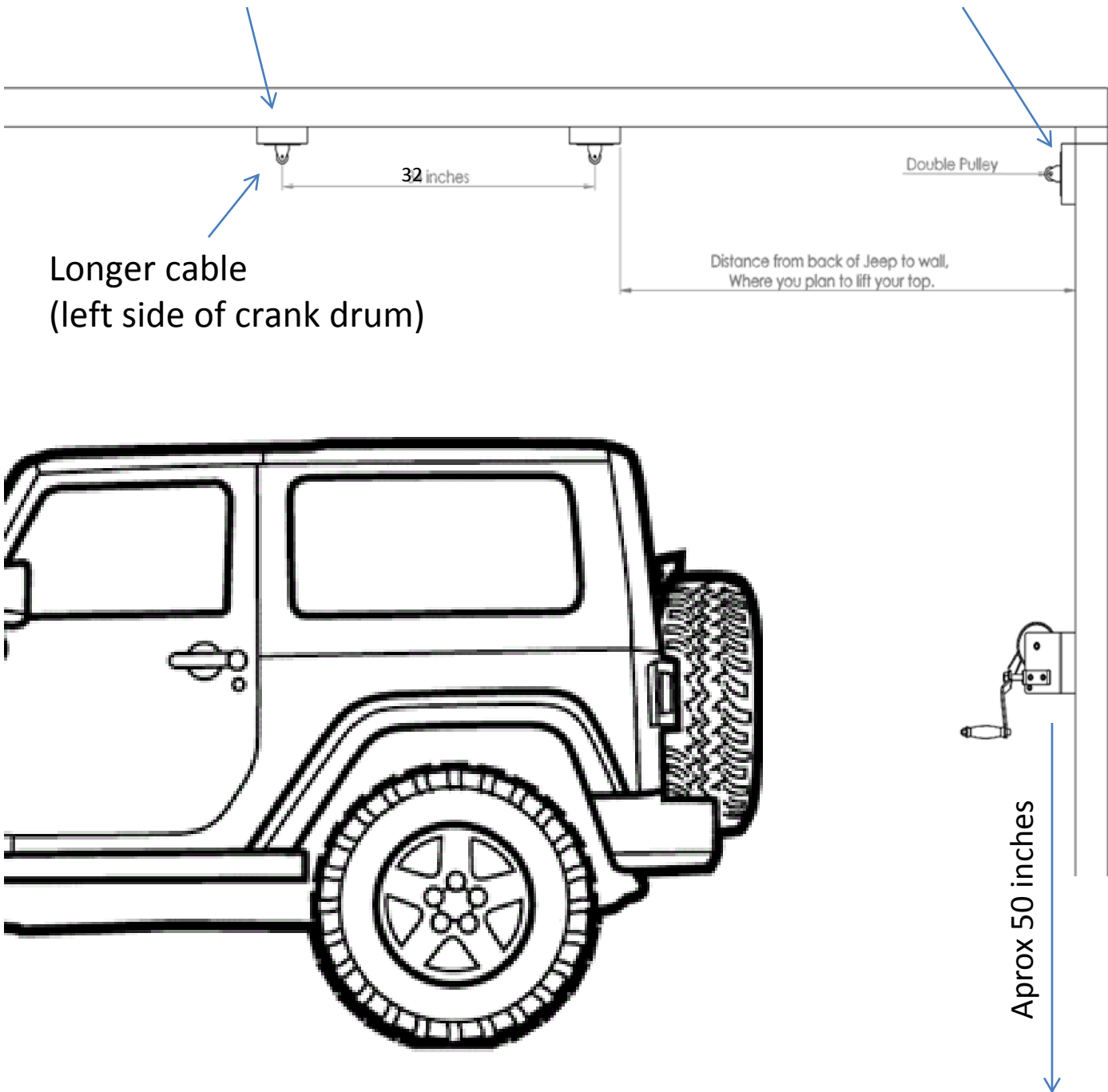

HOIST A TOP[®]

Frame Assembly

- A. Locate the Metal T-Frame Bundle. Slide two of the support arms (HAT-101) into the T-shaped bar (HAT-100) moving the spring button to the appropriate holes as shown in Fig. 3
- B. Slide the Black Foam Holes (HAT-018) on the arms (HAT-101) to protect your hardtop and freedom top pieces. The black round foam pieces should be spaced directly under your Freedom Top Panels during storage.
- C. Slide the JL Foam Square Support (HAT-134) on the T-Shaped bar (HAT-100) over the lifting blade. There is a slit that allows you to do this. Pay close attention to the direction of the JL Foam Square (HAT-134) in Fig. 1, and orient it likewise.
- D. Assemble long foam supports (HAT-135) just in front of the lifting blade (HAT-101) as shown in Fig. 2
- E. Insert the remaining support arm (HAT-101) into the rear of the T-Shaped bar moving the spring button to the appropriate hole as shown in Fig. 4
- F. Put the J-Shaped hooks (HAT-003) through the holes found on each end of the front support arms (HAT-101). Place one hole of the grommet strap (HAT-110) around the threaded part of the J-Shaped hook (HAT-003). Secure with the nylon nuts (HAC-015) to the point of only 3 threads past the nylon part of the nut. Do not over tighten these hooks. We will go over JL Rear Hook installation in the sections to follow.
- G. Insert plastic end caps (HAC-028) to the end of each support arm (HAT-101).

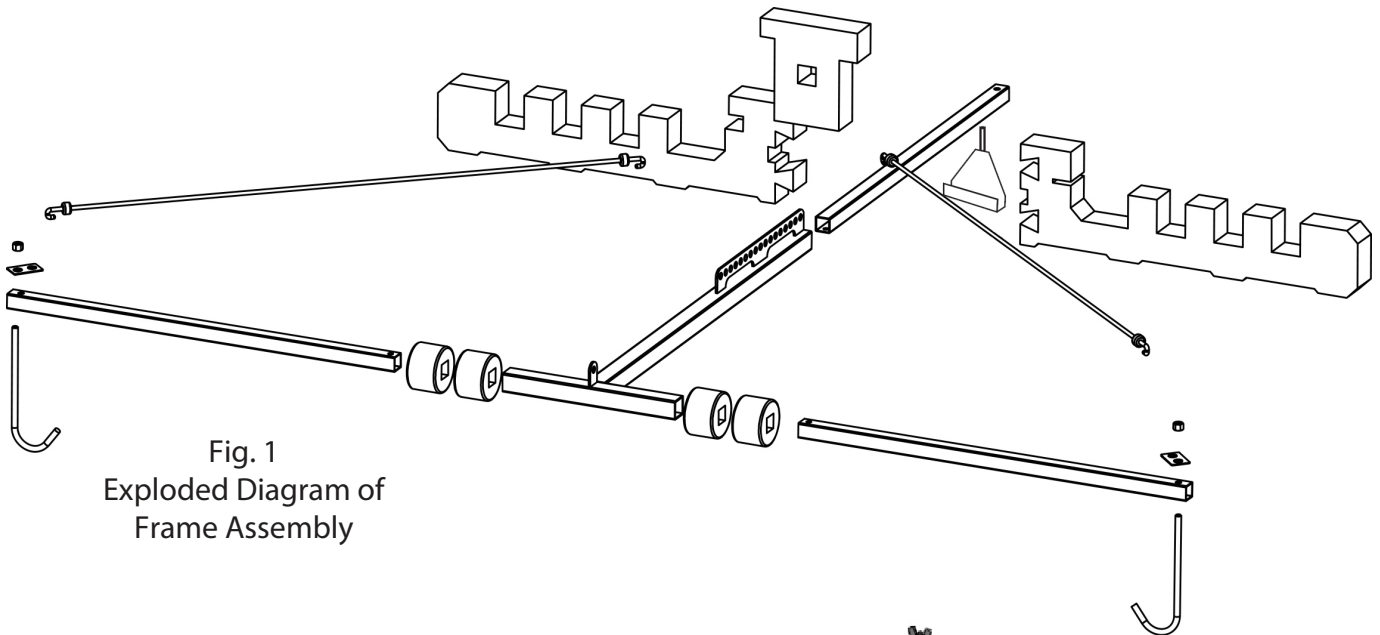

Fig. 1
Exploded Diagram of
Frame Assembly

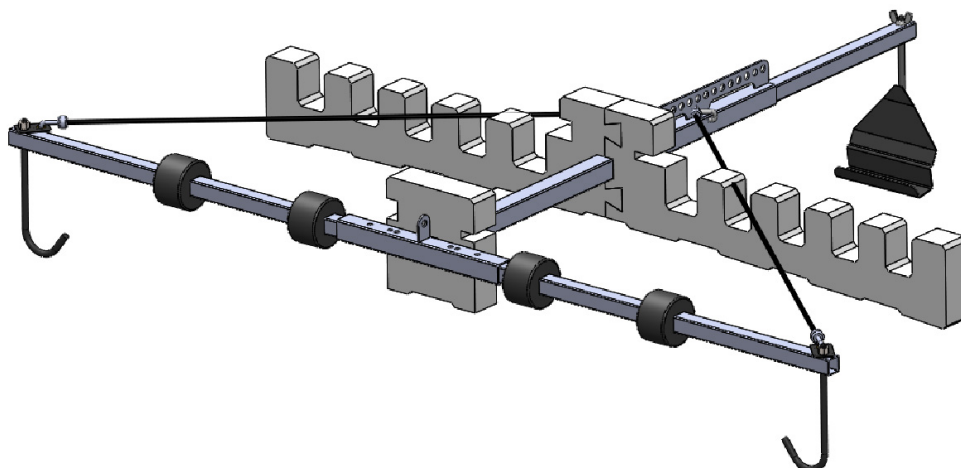

Fig. 2
Completed Frame
Assembly

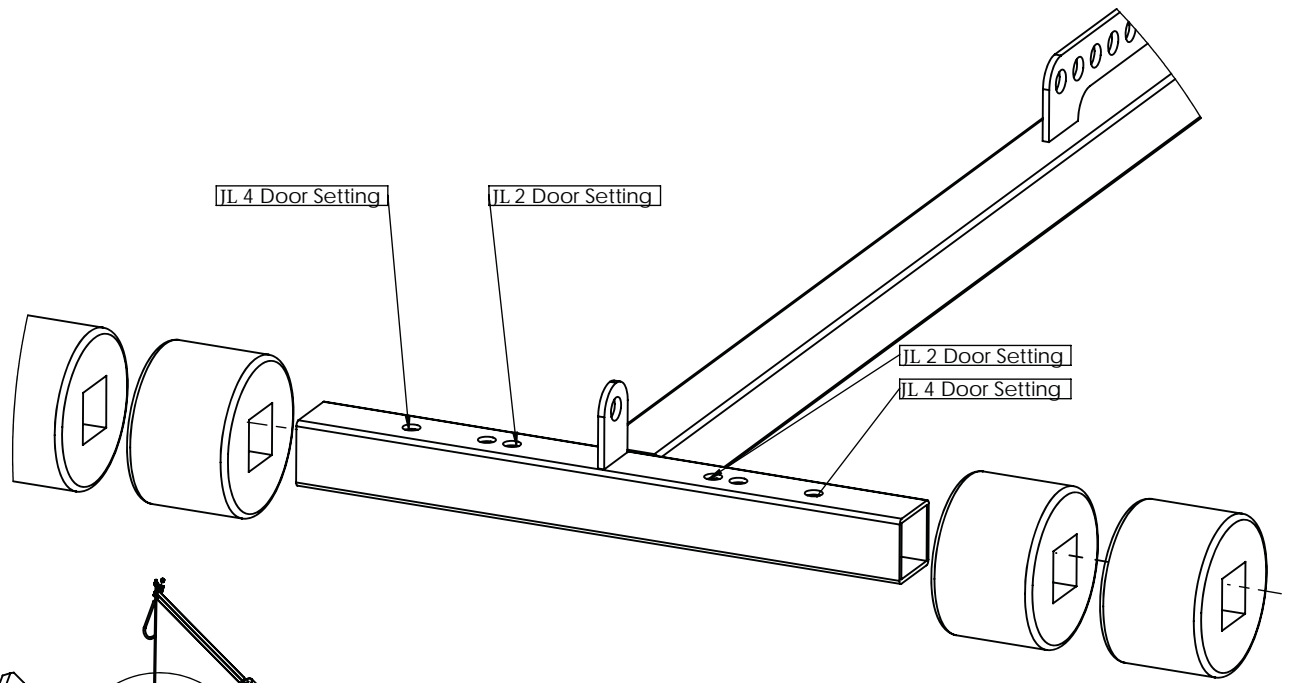

Fig. 3
Front settings for JL

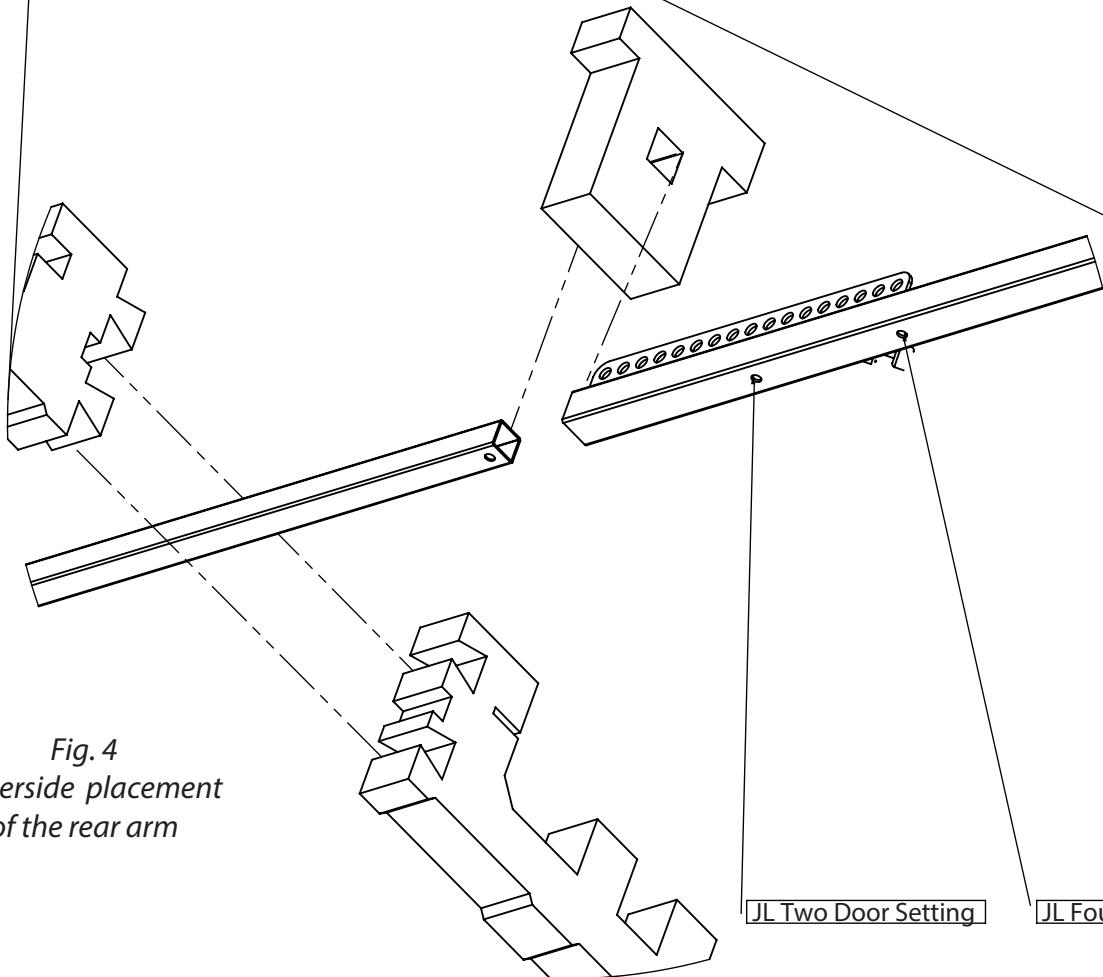
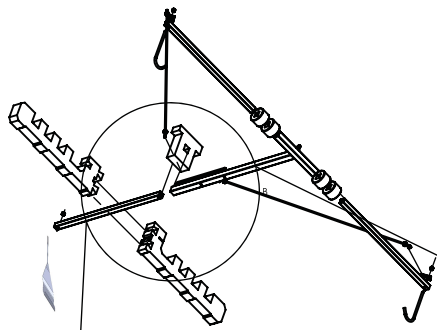
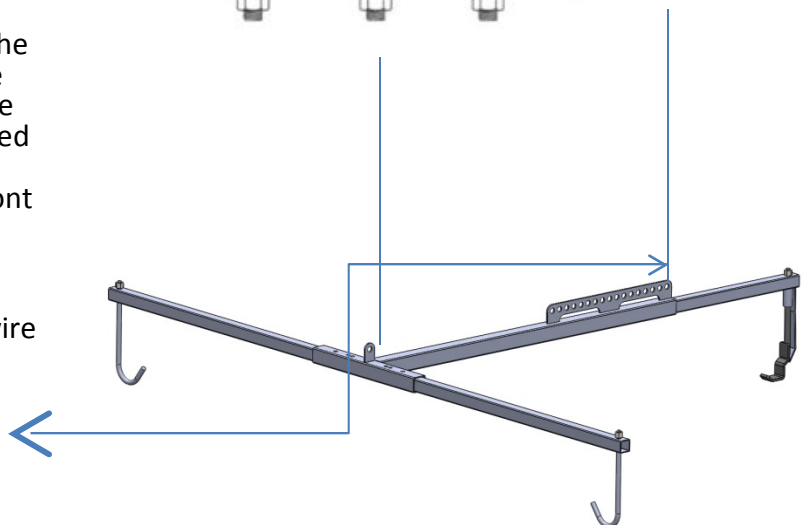
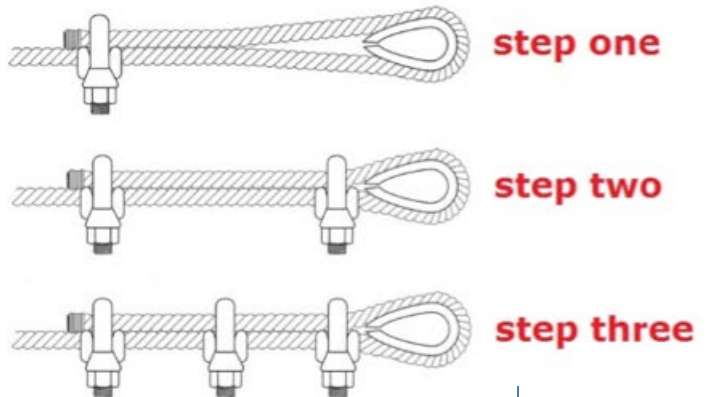
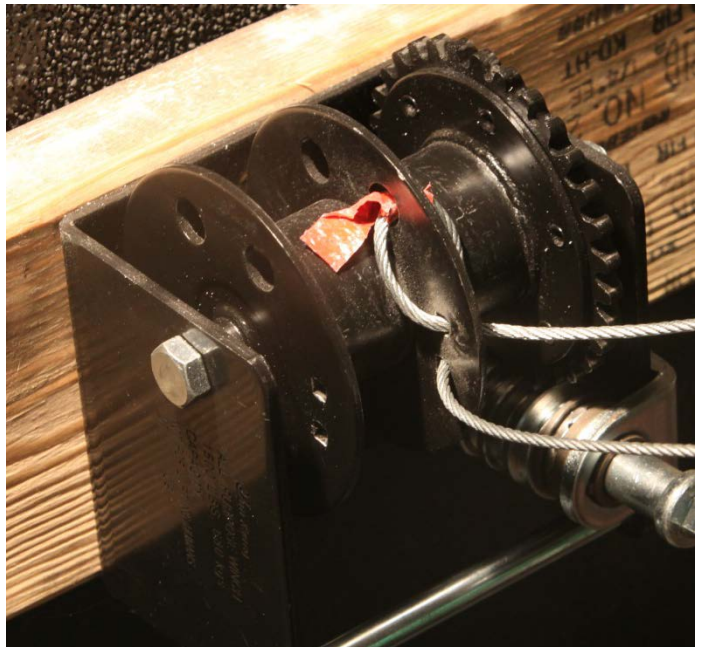

Fig. 4
Underside placement
of the rear arm

Installing the cable

1. Unclip the wire bundle and stretch out the wire. The cable is 43 feet in total. 23 feet for the left side of the drum (the strap side) and 20 feet for the right side of the drum (the hook side)
2. Mark the cable at the 23 foot line with a marker or piece of tape. Center your mark in one of the holes and lace one of each side of the cable through one of the other two holes. You should finish with the longer cable on the left side of the spool.
3. Loop both wire ends through the double pulley in the corner of the ceiling. Take care that the cables don't cross and that the long side stays on the left pulley and the shorter side stays right.
4. Pull the right side cable (the shorter cable) through the middle single pulley in the ceiling. This line will be for the rear of the lifting frame.
5. Pull the right side cable (the longer cable) through the front pulley (this should be the pulley that was installed ½ inch left of center) This cable will attach to the front of the lifting frame.
6. Attach the cables to the front and rear using the wire thimbles and clamps. Use the farthest back hole for the second lifting point.



Lifting Your Top

1. Before you lift your top Test all connections make sure hardware is secure in the ceiling and bolts are tight.
2. Back your jeep into the lifting position. Lower the frame on the center of your hardtop without the JL hook.
3. With the rear window open, take the hook under the window and through the gap carefully with the treads up. Put the treads through the hole in the frame. Using the wing-nut thread it on the hook until you can see three to four threads out of the top of the wing-nut. Do not over tighten.
4. Release all hardware holding down the hardtop. Take care to unplug your wiring harness in the back of the jeep.
5. If you are lifting a top with the Freedom Top® panels, remove them and flip panels over onto the white foam standoffs on the lifting frame.
6. Turn your crank clockwise to begin lifting your top.
7. You may need to adjust the length of the cable attached to either the front or back by loosening the wire clamps and adjusting the length of the cable.



Warranty

We want you to be as happy as we are with our products. Give us a call if you're having trouble we'll be able to help you. We have been lifting tops for 26+ years now and have heard about everything. 9-5 MST is the best time to catch us, but if we miss you leave a message and we'll get right back to you.

We honor a one year warranty from the date of purchase on this product if installed and operated according to these instructions. This warranty is invalid if purchased through an unapproved third party or a unregistered dealer. This warranty covers parts if found defective but does not include: abuse or damage due to neglect or misuse. Liability for any application for the product is limited to the replacement or repair of the product itself and does not cover consequential damage or injury. Use at your own risk.

Please call customer service at 1-866-284-7428 for warranty returns and help. If your product is out of warranty and you need a part, give us a call we can replace most items at a moderate cost to our customers.

About Lange Originals®

Lange is a family started, owned and run business. Our first Hoist-A-Top idea came In 1988 when we struggled to remove a top on a brand new YJ Wrangler. Original prototypes were made from wood and then metal in our home garage. We no longer work out of the garage but your purchase still puts food on our tables, braces on teeth, and roofs over our heads. We are grateful for your patronage. If there is anything we can do to continue to have your business, please let us know.