

GT
MOMENTUM™

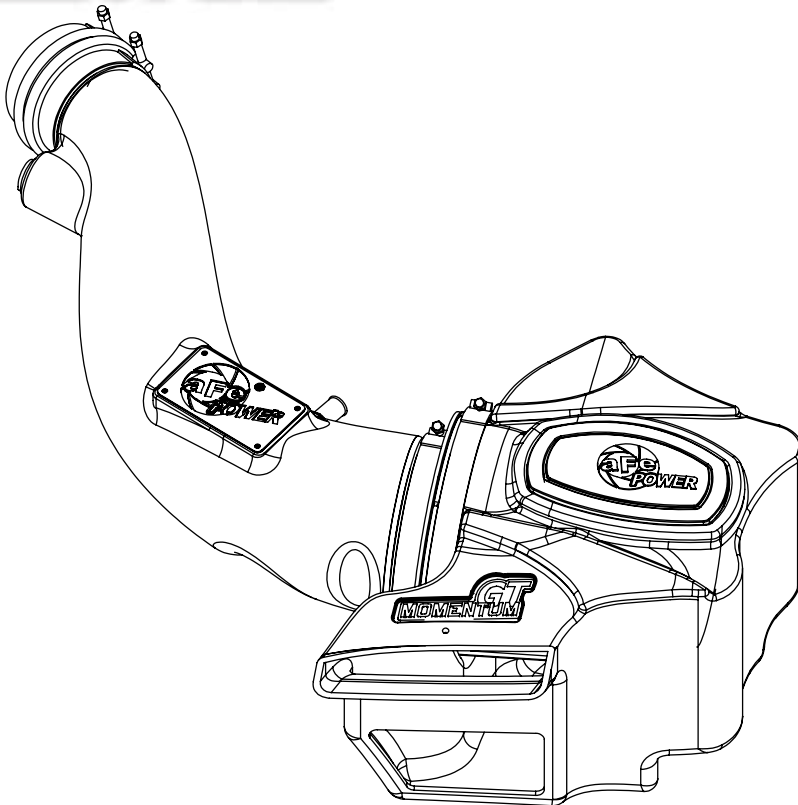

advanced FLOW engineering

Instruction Manual P/N: 54-76214 / 51-76214

Make: **Jeep** Model: **Grand Cherokee (WK2)** Year: **2016-2019** Engine: **V6-3.6L**
Make: **Dodge** Model: **Durango** Year: **2016-2019** Engine: **V6-3.6L**



- Please read the entire instruction manual before proceeding.
- Ensure all components listed are present.
- If you are missing any of the components, call customer support at 951-493-7100.
- Ensure you have all necessary tools before proceeding.
- Do not attempt to work on your vehicle when the engine is hot.
- Disconnect the negative battery terminal before proceeding.

Retain factory parts for future use.

Label	Qty.	Description	Part Number
A1	1	Air Filter (Pro DRY S)	21-91062
A2	1	Air Filter (Pro 5R)	24-91062
B	1	Tube	05-76214B1
C	1	Housing	05-76214B2
D	1	Coupling, Silicone Reducer	05-01400
E	2	Clamp, T-Bolt (3-1/4"-3-9/16")	03-50292
F	1	Clamp, T-Bolt (7.00"-7.38")	03-50290
G	1	Grommet	03-50167
H	1	Fitting, Air Temp Sensor	05-01454
I	1	Breather Hose: 1/2" x 30" Length	05-01422

Tools Required: 8mm nut driver, 10mm nut driver, 12mm nut driver & deep socket.
Recommended: panel popper and flat head screwdriver.

Note: Not legal for use in California. The use of this device in any on-road or off-road vehicles registered with the California Dept of Motor Vehicles (DMV) is strictly prohibited.

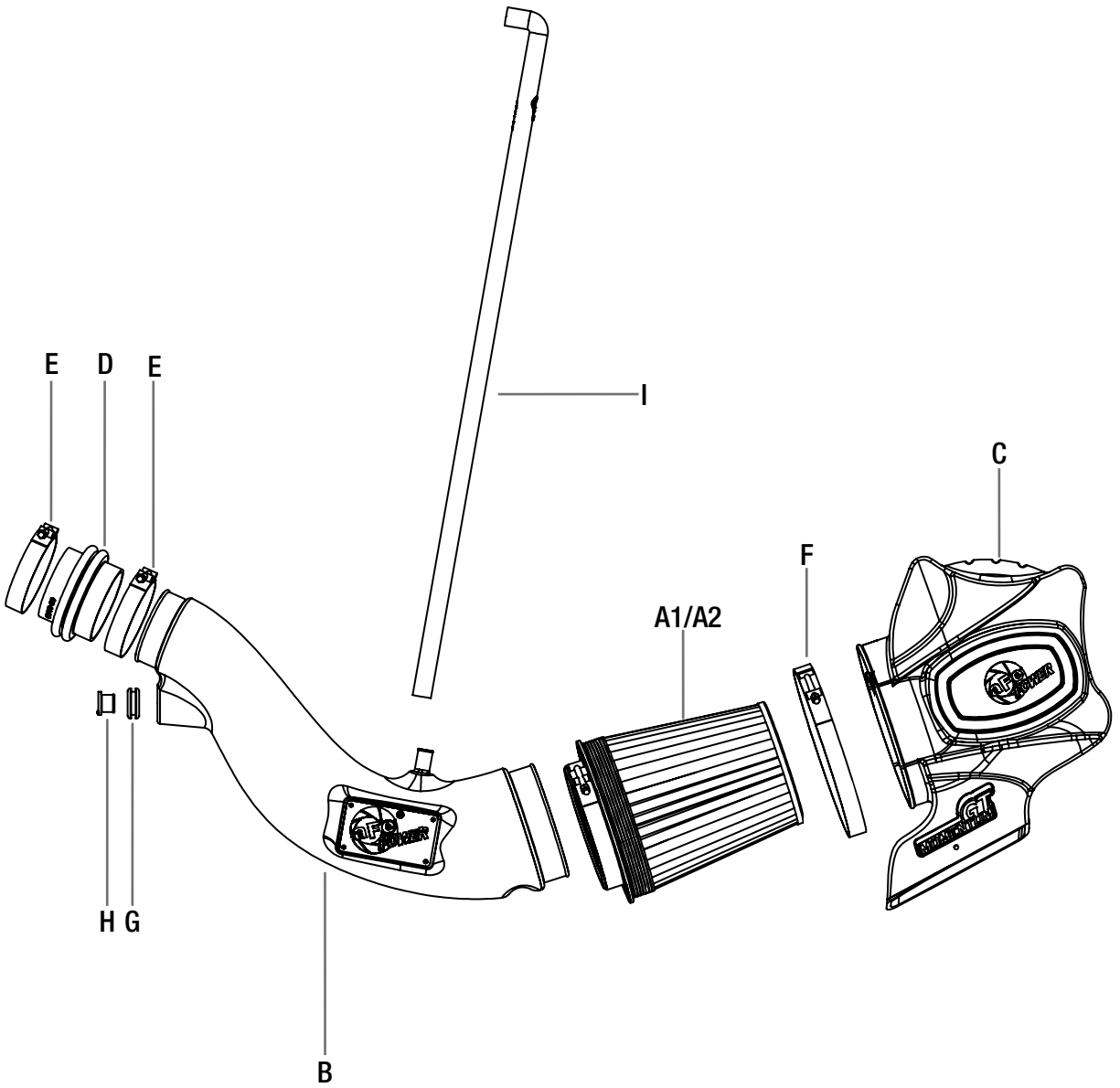

**Figure A****Refer to Figure A for Steps 1-2**

Step 1: Remove the cover by pulling up firmly.

Step 2: Remove the OE screw (1), then carefully pull off the engine cover.



Figure B

Refer to Figure B for Steps 3-7

Step 3: Carefully pull up and remove the trim seal (2) on top of the factory intake scoop plus 2-3 clips on either side. This helps with the removal of the factory airbox and installation of the aFe housing.

NOTE: It may help to use a panel popper when pulling the clips.

Step 4: Disconnect the temp sensor wire harness. (3)

Step 5: Loosen the hose clamp at the throttle body. (4)

Step 6: Disconnect the vent hose from the air box along with the power steering hose clip. (5)

Step 7: Remove the stock intake tube, and air filter housing by pulling straight up and out of the vehicle.

**Figure C****Refer to Figure C for Step 8-10**

Step 8: Transfer the (x3) rubber grommets ⑥ from the OE housing to aFe housing as shown.

Step 9: Preassemble the housing as shown by inserting the aFe filter into the housing and tightening the large T-bolt clamp using your 12mm nut driver. ⑦

Step 10: Install the housing assembly into the vehicle. It may help to align the back-lowest rubber grommet with your hand first and the others will follow. Press down firmly to securely seat the housing.



Figure D

Refer to Figure D for Step 11-13

Step 11: Install the supplied grommet into the aFe tube, then push the aluminum fitting into it. ⑧

NOTE: It may help to use a small amount of lubricant on the inside of the rubber grommet.

Step 12: Remove the temp sensor from the factory tube with a 90 degree turn counter clockwise. Be sure not to damage the sensor.

Step 13: Carefully insert the temperature sensor into the aluminum fitting and secure by turning clockwise. ⑨



Refer to Figure E for Steps 14-15

- Step 14: Follow the OE crankcase hose to the rear of the engine (10) . Disconnect from the mounting location. (11)
- Step 15: Once the OE crankcase vent hose is removed, replace it with the supplied aFe hose by slipping the shorter end behind the engine. Leave the longer end open for the aFe tube. (12)



Figure F

Refer to Figure F for Steps 16-17

Step 16: Install aFe coupling and clamps over the throttle body.

Step 17: Tighten clamp at throttle body only (13) . Do NOT tighten clamp for tube. (14)

**Figure G****Refer to Figure G for Steps 18-21**

Step 18: Install the aFe tube. Slide the tube into the air filter first. Do not tighten clamps.

Step 19: Then slide the tube into the coupling.

Step 20: Adjust the tube to sit comfortably, then tighten all clamps.

Step 21: Reconnect temperature sensor harness. ⑮



Figure H

Refer to Figure H for Steps 22-25

Step 22: Slip the new aFe crankcase vent hose onto the aFe tube.

Step 23: Verify all connections are secured.

Step 24: Reinstall the rubber trim seal into factory locations and onto the aFe housing. ¹⁷

Step 25: Reinstall engine cover removed in page #4. Your installation is now complete. ¹⁸

NOTE: Check all clamps and connectors after 200 miles.



PAGE INTENTIONALLY LEFT BLANK

PAGE INTENTIONALLY LEFT BLANK



Pro DRY S Air Filter



P/N: 21-91062

Pro 5R Air Filter



P/N: 24-91062

Pro DRY S Restore Kit



P/N: 90-59999

Blue Squeeze Restore Kit



P/N: 90-50501

Blue Aerosol Restore Kit



P/N: 90-50001

To purchase any of the items above, view airflow charts, dyno graphs, photos, and video; please go to aFepower.com.

Warranty

General Terms:

- aFe warrants their products to be free from manufacturer's defects due to workmanship and material.
- This warranty applies only to the original purchaser of the product and is nontransferable.
- Proof of purchase of the aFe product is required for all warranty claims.
- Warranty is valid provided aFe instructions for installation and/or cleaning were properly followed.
- Proper maintenance with regular inspections of product is required to insure warranty coverage.
- Damage due to improper installation, abuse, unauthorized repair or alteration is not warranted.
- Incidental or consequential damages or cost, including installation and removal of part, incurred due to failure of aFe product is not covered under this warranty.
- All warranty is limited to the repair and/or replacement of the aFe part. To request Return Goods Authorization ("RGA"), email RGA@afepower.com or call (951)493-7100. Upon receipt of the RGA, you must return the product to the address provided in the RGA, freight prepaid and accompanied with a dated proof of purchase and the RGA. Upon receipt of the defective product and upon verification of proof of purchase, aFe will either repair or replace the defective product within a reasonable time, not to exceed thirty days.

Product Category	P/N Prefix	Warranty duration
Direct OE Replacement Filters	10, 11, 30, 31, 71, 73	Life of the vehicle
Racing Filters	18	1 year
Universal	21, 24, 72	2 years
Air Intake Systems	50, 51, 54, 55, 75	2 years
Exhaust Systems	49	2 years
Intercoolers & Intercooler Tubes	46-2	2 years
Intake Manifolds	46-1	2 years
Differential Cover	46-7	Life of the vehicle
Exhaust Manifolds	46	2 years
Throttle Body Spacers	46-3	2 years
Fluid Filters	44	90 days
Pre-Filters	28	2 years
Heavy Duty OE Replacement	70	2 years
PowerSports OE Replacement	81, 87	2 years
PowerSports Intake Systems	85	2 years

No other warranty expressed or implied applies nor is any person or advanced FLOW engineering authorized to assume any other warranty. Some States do not allow the exclusion or limitation of incidental or consequential damages or do not allow limitations on how long an implied warranty lasts, so the above limitations or exclusions may not apply to you. This warranty gives you specific legal rights, and you may also have other rights which vary from State to State.



advanced FLOW engineering, inc.
252 Granite Street Corona, CA 92879
TEL: 951.493.7100 • TECH: 951.493.7134
E-Mail: Tech@aFepower.com