



Rallye 4000

460 818-08/6/98

**Montageanleitung Hella
Nebelscheinwerfersystem Luminator**

Besseres Licht - einfach montiert

**Installation Instructions for Hella
Luminator Auxiliary Fog Lamps**

Better Light - Simple to Install

**Instructions de montage Projecteurs
de complément Hella Luminator**

Un meilleur éclairage - facilement monté

**Monteringsanvisning Hella
extrastrålkastare Luminator**

Bättre ljus - lätt att montera

English

The tremendous amount of design and development work which goes into fog lights is not immediately obvious. However, all well-known motor vehicle manufacturers such as Audi, BMW, Daimler Benz, Ford, Fiat, Renault, Opel, Saab, Volvo and VW fit Hella lamps as original equipment. This speaks volumes for the trust they place in Hella. And it is your guarantee for the reliability of Hella equipment and accessories.

Accessories (not included with lamp set)

1. Protective grille
2. Single pole wire connector
3. Mounting strip for switches
4. Two-point mount
5. Switch
6. Hella wiring harness with relay and fuse
7. Bulbs (H3 12 V / 55 W item No.: 8GH 002 090-131)
(H3 24 V / 70 W item No.: 8GH 002 090-251)

Installation dimensions

Lamps should not vibrate or extend above the bonnet. They should be attached symmetrically. Determine the installation dimensions according to the drawing/table below (figs. 1 and 2).

● means not higher than dipped beam headlamps.

Installation

Tools required:

- | | |
|------------------------------------------|----------------------------|
| Pliers for crimp connectors if available | Ruler |
| 3 mm and 6 mm dia. Allen wrenches | Pair of combination pliers |
| Drill with 3 mm, 10, mm, 11 mm dia. bits | Open-end wrenches |

Remove the glass retaining rim and take out the headlamp insert. Mark fixing points on stable surface and drill (see Fig.).

Seal drilled holes with antirust!

We recommend upright attachment using the two-point mount available as an accessory.

For pendant mounting drill two additional 5 mm dia. water drain holes (see Fig.). Screw the headlamp base tightly to the fixing surface and screw the headlamp base „handtight“ to the housing (see Fig.).

Insert the proper Hella bulbs (available as accessories) and attach the wires. Do not touch bulbs with bare fingers! Use paper towel or similar.

Ensure that the marking „top“ is always at the top of the lens when installing the headlamp insert to ensure optimum light distribution.

Now attach glass retaining rim and screw down tight. The retaining lug should point toward the base (see Fig. 4).

Electrical connection:

Install proper Hella relay (available as accessory) with connection terminals pointing downward so that it is protected against splashing water (see circuit diagrams).

- | | |
|----------------|----------------------------------|
| 24 V headlamps | Relay item No.: 4 RA 003 510-651 |
| 12 V headlamps | Relay item No.: 4 RA 003 510-361 |

Install the switch included on the dashboard. Instead of the Hella switch, you can use a vehicle-specific switch from your car dealer.

Disconnect earth lead (-) from battery for safety.

Lay wires according to circuit diagram. Find the circuit diagram which applies for you by means of the table (Fig. 3) and follow any additional instructions given in the table.

● allowed by law

Then simply hook wires onto rear of headlamp.

Reconnect earth cable (-); check lights!

Headlamp adjustment:

Have your fog lamps adjusted at a garage or filling station so that they illuminate the road effectively without dazzling oncoming traffic. After adjusting the headlamps tighten the lamp base on the housing. Use of enclosed protective caps is not permissible according to German traffic code.

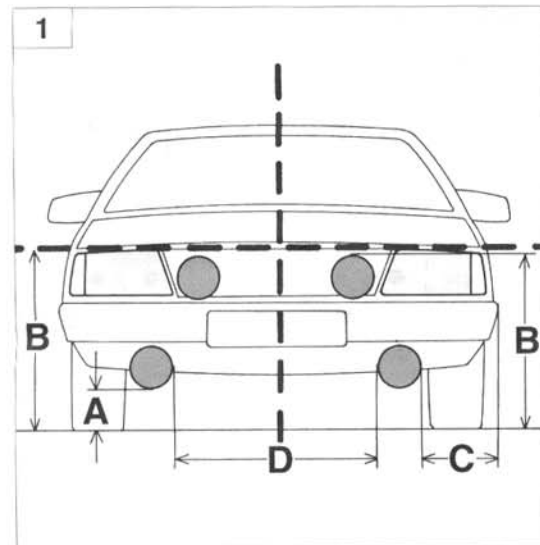

2	A min. (mm)	B max. (mm)	C max. (mm)	D min. (mm)	3			
					⊕D	⊕D	⊕D	⊕D
⊕D		●			⊕D	⊕D	⊕D	⊕D
A		●	400	600		●		
CH	250	1.200	400			●	●	●
GB	250	●	400	350			●	
F	250						●	
B	●	1.200	400		●	●	●	●
S	250	●	400			●	●	●

