

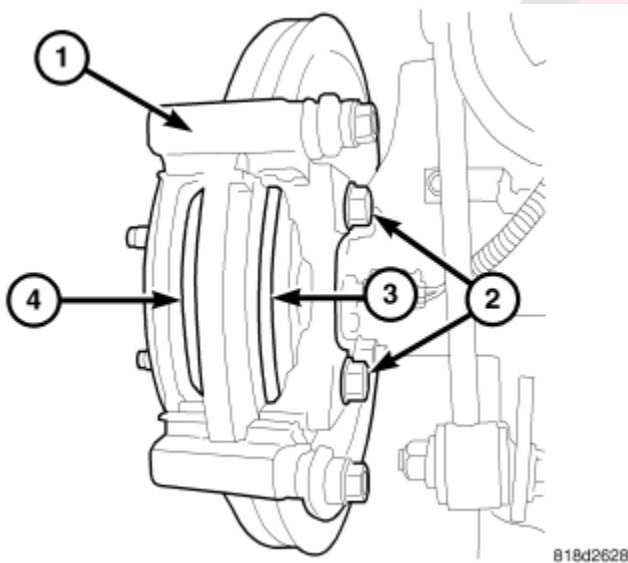

GENERAL NOTES:

- Gear set up and installation should be performed by someone experienced in gear and axle set up
- Special tools are require for proper gear set up, here is a list of them:
- Micrometer or calipers
- Bearing splitter and press
- Housing spreader
- Dial indicator with magnetic base
- Brass tipped hammer and drift

1. Support vehicle securely on jack stands or automotive lift and remove the wheels



2. Remove the brake caliper mounting bracket from axle using a 18mm socket and remove the brake calipers and rotors, hang or tie the brake calipers to the frame out of the way.

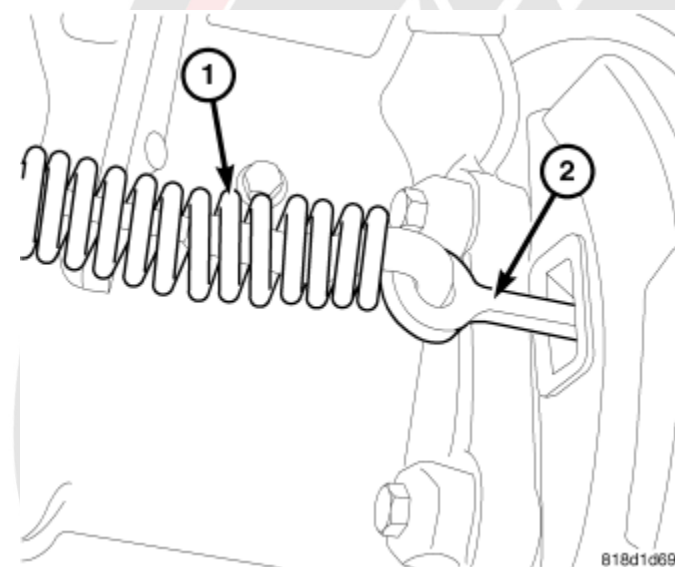

3. Remove parking brake cables (1) from support plate (2)

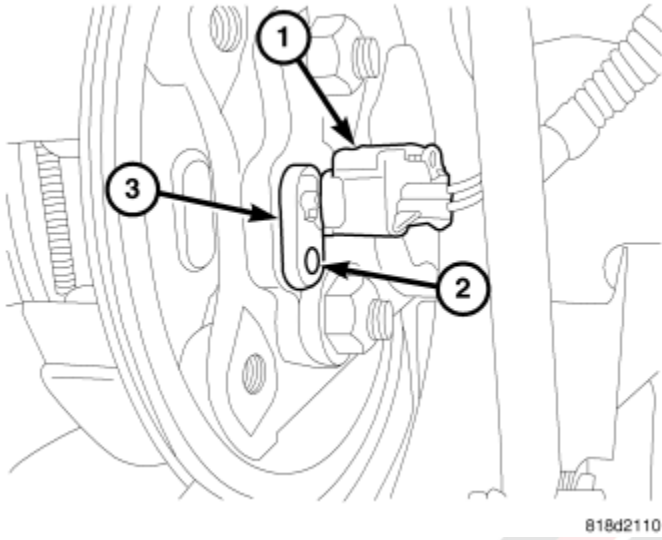

4. Remove the ABS sensor (3) from the support plate with a 8mm socket

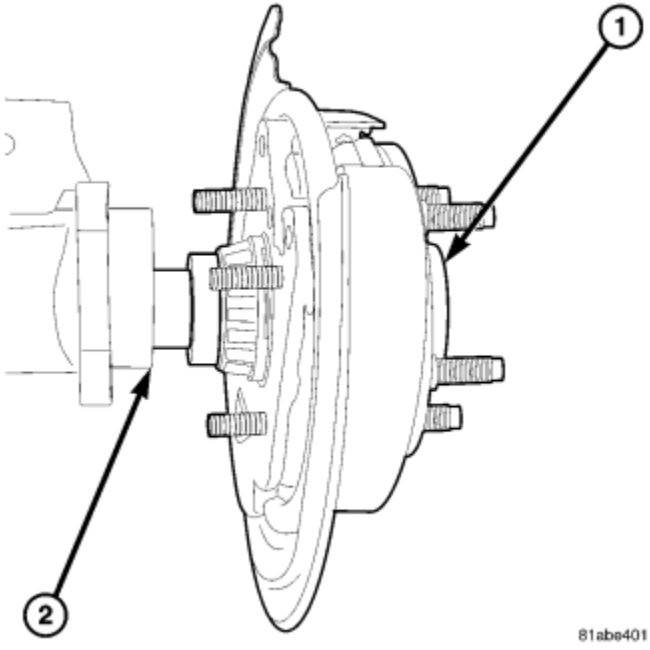

5. Remove the 4 axle retainer plate nuts with a 18mm socket and remove the axle shafts

6. Drain differential and remove differential cover.
7. Remove the driveshaft from the rear pinion yoke

8. Unplug diff lock chassis harness from the bulkhead connector (1) and the diff lock sensor (2)

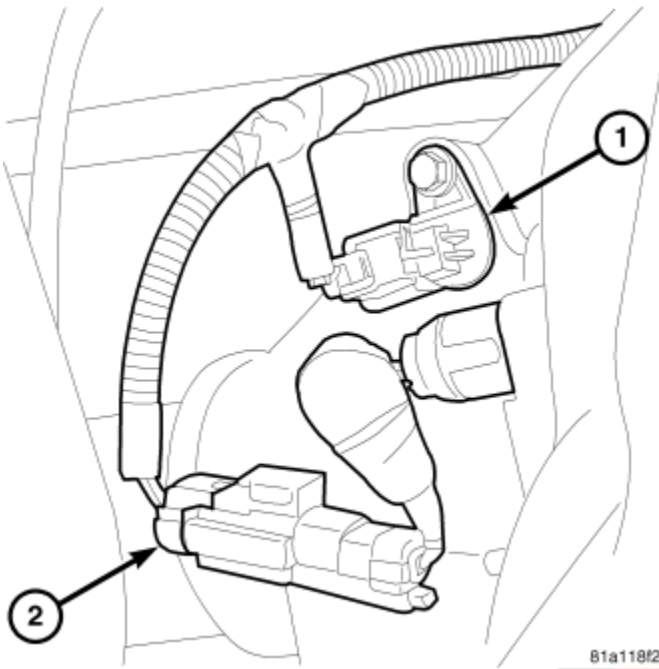

B1a118f2

9. Remove the diff lock bulkhead connector using an 8mm socket, pull the connector out of the housing and disconnect the locker coil wires from the bulkhead connector.

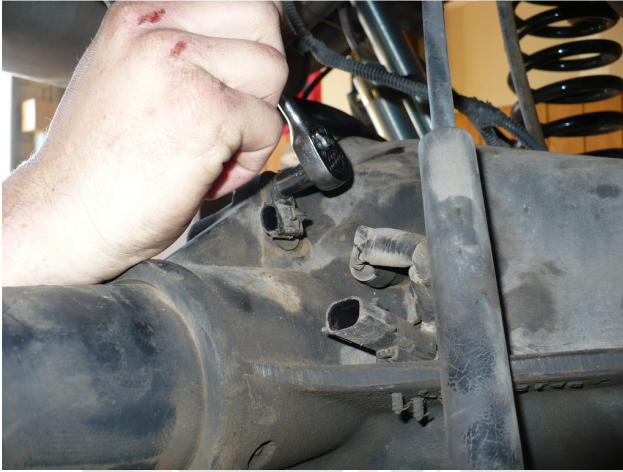

10. Remove the differential bearing cap bolts using a 3/4" socket. The differential bearing caps are matched to the side they came from, there should be a matching horizontal (1) and vertical (2) letter stamped on the bearing cap and adjacent diff cover mounting surface. If they are not marked, mark them now.

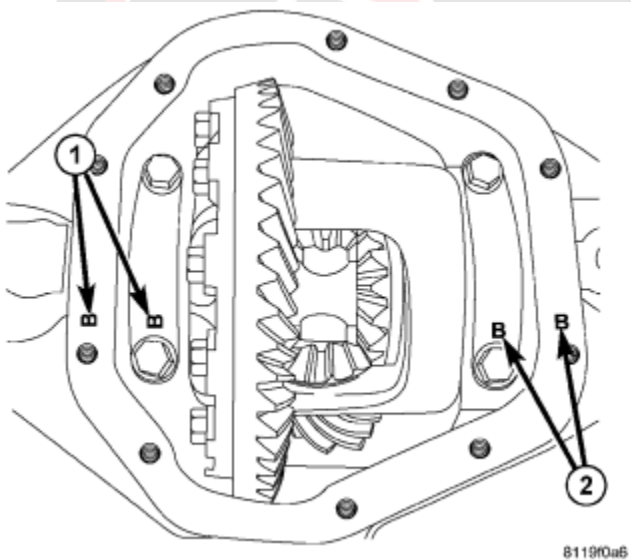

B119f0a6



11. Remove the differential carrier assembly; keep track of which side the carrier bearing races and shims came from. The bearing races need to be installed on the side they were originally in. Measure and record the thickness of each shim in the diff set-up sheet, the sum of these two shims will be the total shim thickness needed for the carrier bearings, keep the total shim thickness for your backlash adjustments and final carrier installation.

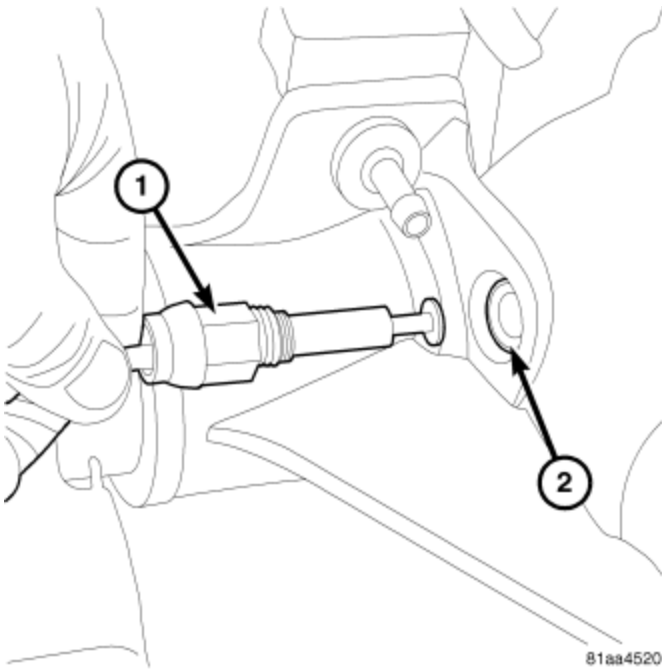

12. Remove the locker indicator sensor (1) from the housing (2) using a $\frac{3}{4}$ " wrench



13. Measure the pinion bearing torque to rotate using an in-lb dial or beam type torque wrench. The torque to rotate should be in the 10-20 in-lb range. Record this number in the diff set-up sheet for future installation if re-using the original pinion bearings.



14. Remove the pinion yoke nut with a $1 \frac{5}{16}$ " socket. Using a brass tipped hammer or brass punch, tap on the end of the pinion shaft to remove it from the housing. Make sure the crush sleeve comes out with the pinion gear.

15. Carefully inspect the all of the bearings for abnormal wear or scarring, the bearings can be reused if this is a low mileage gear swap and if the bearing are in good condition. Use care when removing and installing the pinion and yoke, you do not need to remove the pinion seal and outer pinion bearing if you are not replacing them. If you are going to replace the bearings, now is a good time to replace them. The carrier bearings are very difficult to remove, it requires a special bearing puller or to cut the bearing to split it to remove it. If replacing the pinion bearings remove the pinion seal and change the bearing races in the housing. Do not put a new pinion seal in until final assembly.

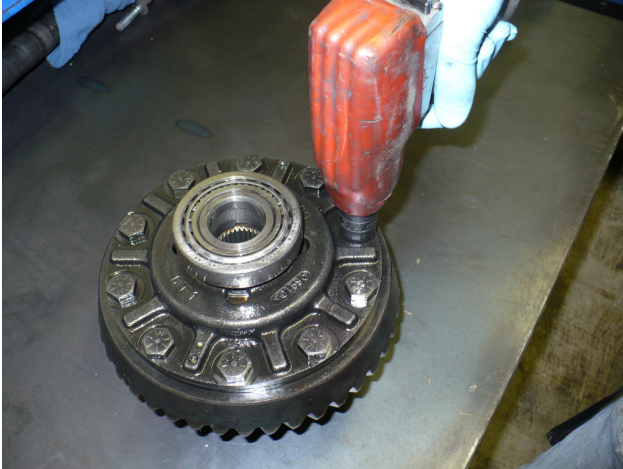

16. Remove the ring gear bolts using a 13/16" socket, the ring gear should have a light press fit on the carrier, thread a few of the bolts in the ring rear and tap the bolts to remove the ring gear, be careful not let the ring gear fall on the coil or wires for the locker.

17. Carefully clean the ring rear mounting surface of the carrier and new ring gear, run a fine file or sand paper over the mounting surface to remove any burrs or high spots.

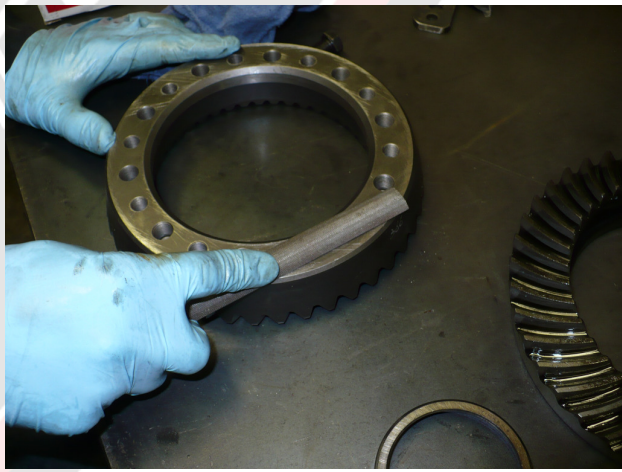
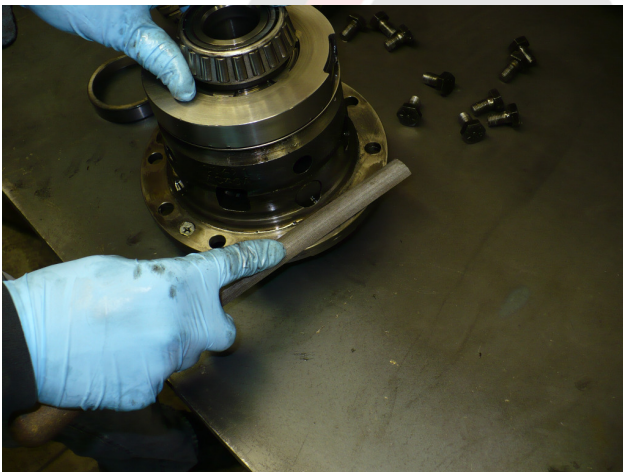

18. Clean the threaded holes in the ring gear and ring gear bolts with brake or carb cleaner. Early JKs used 7/16" ring gear bolts and later ones use 1/2" ring gear bolts. We have supplied only 1/2" bolts in our install kit. If your JK has 7/16" bolts you can either drill out the carrier holes to 1/2" or buy 7/16" bolts, the ring gear is tapped for both. 7/16" ring gear bolts are available from you local Jeep dealer, they are not that expensive (\$8 for the set), P/N 68003554-AA. Use the supplied split lock washers on the 1/2" ring gear bolts. Put a small amount of the

supplied red thread locker on the first few threads of each ring gear bolt. Use only new ring gear bolts, do not use used ones. Place the new ring gear on the carrier and start all of the ring gear bolts. Alternately tighten the ring gear bolts to pull the ring gear on the carrier. Torque the 1/2" bolts to 100 ft-lbs or 7/16" bolts to 65 ft-lbs.

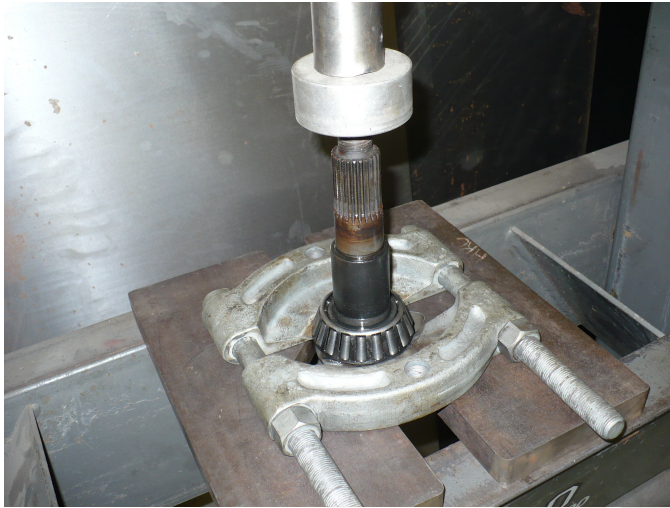

19. Remove the inner pinion bearing from the pinion gear; this bearing will be re-used if you are not changing the bearings. The easiest way is to use a bearing splitter and a press. The pinion depth shim is between the bearing and pinion gear, save this shim and record the thickness in the gear set-up sheet, you will use it on the new gears.

20. Install the original pinion shim (1) on the new pinion gear and press on the original pinion bearing if re-using or new bearing if using new bearings. A piece 2" x .120 wall tube works well for this.

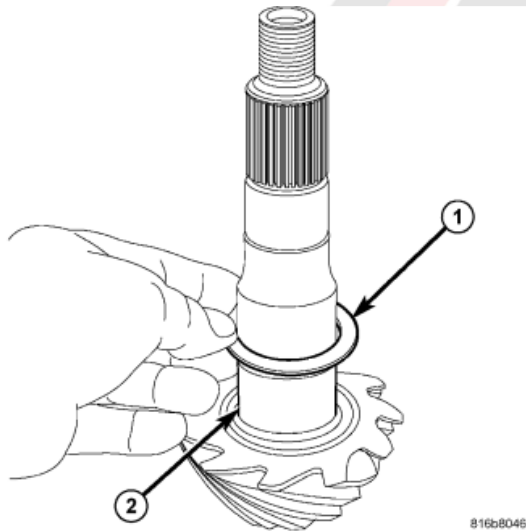

21. Put a small amount of grease on the outer pinion bearing surface and splines of the new pinion gear. Install the pinion into the axle housing without a crush sleeve. Slide the pinion yoke onto the pinion shaft splines and tap the pinion yoke with a brass hammer to seat the outer pinion bearing onto the pinion shaft until enough threads are showing to start the pinion nut. Be careful to not damage the pinion seal. Use the original pinion nut until final pinion assembly with the new pinion nut and new crush sleeve. Tighten the pinion nut to reach the original torque to turn value or 10-20 in-lbs.

22. Install the carrier assembly into the diff housing. Use the original carrier shims but swap them from side to side to get a baseline for the gear backlash. Make sure the carrier bearings and bearing caps are on the same side they were removed from. Tighten the bearing caps to 80 ft-lbs.

23. Check the gear backlash with a dial indicator, try to align the indicator as perpendicular as you can to the drive side of the gears. Gear backlash should be in the .006-.010" range, .008" is preferred. Adjust the thickness of the carrier shims to get the desired amount of backlash (Refer to the illustration below to adjust backlash). The total carrier shim thickness should remain the same as the original shims, what ever you take from one side you need to add to the other side. A rough rule of thumb to change the carrier shim thickness is a 1.5:1 ratio of the amount of backlash you want to change. For example, if you want to change the backlash by .004", shim the carrier over by .006". Record each trial set up in the diff set-up sheet so you can keep track of all your measurements and results.

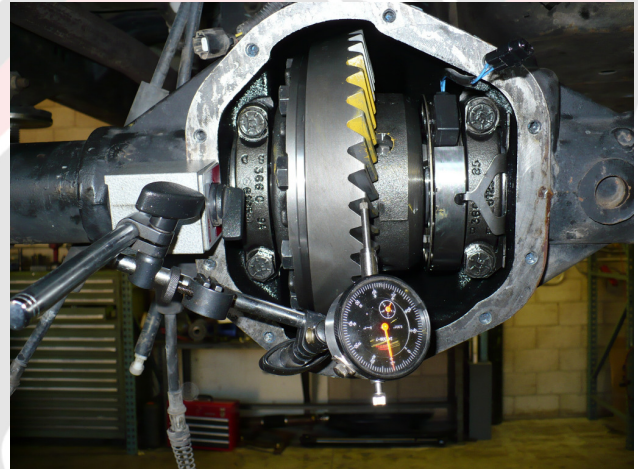
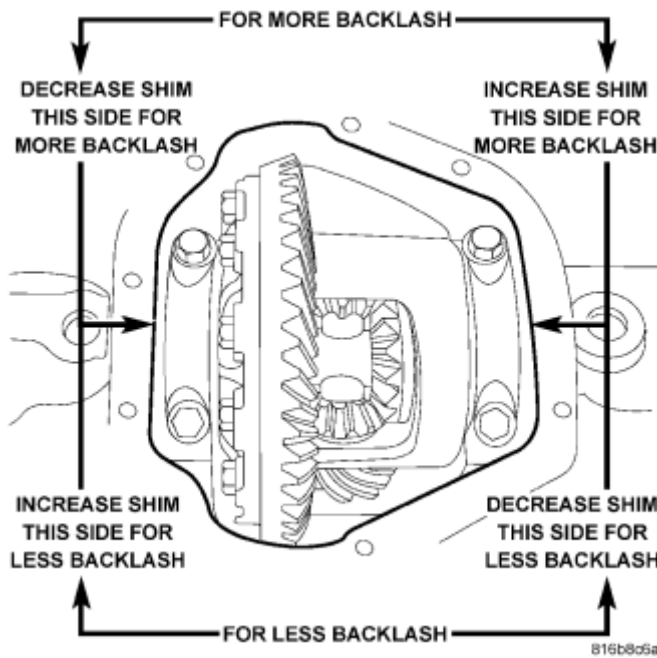

24. Once you have the backlash in spec, use the gear marking compound to check the gear mesh pattern. Paint about 4 teeth on both the coast side and drive side. Put some drag on the carrier by pushing on it with your hand and a rag. Turn the pinion gear so the painted teeth run across the pinion both directions a few times. The gear mesh pattern will be the best indication of the gear set up and will show you what adjustments you need to make to the pinion shim.

25. READING THE GEAR MESH CONTACT PATTERN

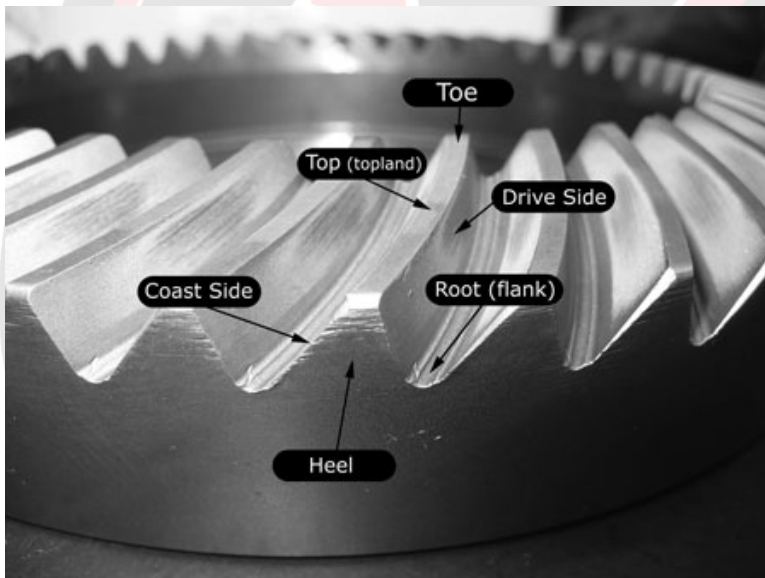

- The gear mesh pattern will show you how to change the pinion shim; the backlash will not affect the gear mesh pattern much, just keep the backlash in spec.
- Pay attention to the contact pattern between the top of the gear tooth and the root. The contact pattern should be centered between the top and the root with soft edges
- If the contact pattern is heavy towards the top of the gear tooth you need to move the pinion closer to the ring gear by adding pinion shim. The contact pattern will move toward the root, the drive side pattern will move toward the toe, the coast side will move toward the heel.

(Continued on Next Page)

(Step 25 Continued from Previous Page)

- If the contact pattern is heavy towards the root of the gear you need to move the pinion away from the ring gear by subtracting pinion shim. The contact pattern will move toward the top, the drive side pattern will move toward the heel, the coast side pattern will move toward the toe.
- If you make pinion shim adjustments the backlash will also be affected, if you add pinion shim you will need to move the ring gear away from the pinion to keep the backlash within spec. If you remove pinion shim, you will need to move the ring gear closer to the pinion gear to keep the backlash within spec. Make pinion shim adjustments in .005" increments then take a pattern check.

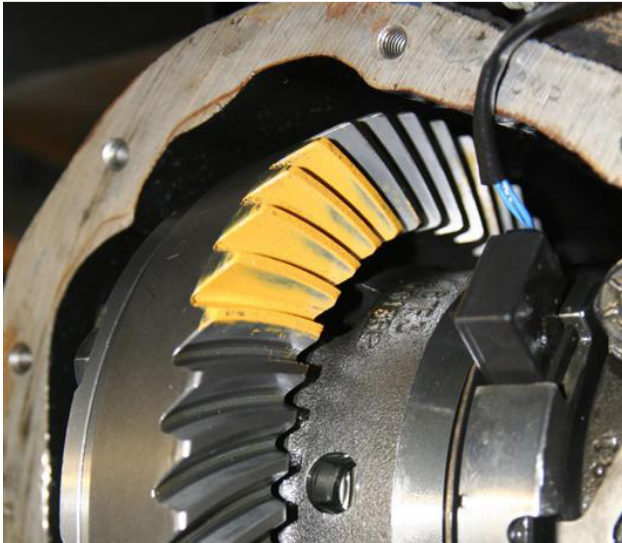

This shows the coast side of the gear tooth with the pinion shim way too far away, try adding .025 to the pinion shim.



Contact pattern is close but pinion is still too far way, try adding .010 to the pinion shim



Ideal contact pattern of drive side



Ideal contact pattern of coast side

26. Once you have a good contact pattern and backlash measurement, you can begin final gear assembly. Remove the carrier and pinion.

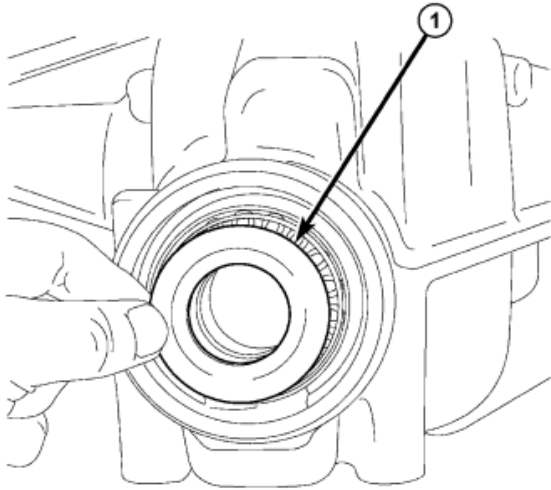

B16b005c

27. If you are replacing the pinion bearings and seal, make sure the new bearings races are installed in the housing, put the oil slinger behind the outer pinion bearing if used and install the pinion seal.



28. Clean the pinion splines and the inside of yoke with brake or carb cleaner. Apply some silicone sealer in the splines of the yoke near the pinion nut end. This will prevent gear oil from leaking through the splines in the yoke. Apply some fresh gear oil to the bearings. Install the pinion and yoke using the new crush sleeve and new pinion nut. You will need to tighten the pinion nut to collapse the crush sleeve to obtain the correct amount of torque to turn the pinion. You can do this with a good impact wrench or a long breaker bar and something to hold the pinion yoke. Be careful to not over tighten the pinion nut, damage to the bearings can result and you will need a new pinion nut and crush sleeve

to redo it. Tighten the pinion nut to take the end play out of the bearings and then tighten a little at a time and check the torque to turn often. Turn the pinion a few times before taking torque to turn measurements to seat the bearings. If using the original bearings, tighten the pinion nut to get the original torque to turn value or 10-20 in-lbs. If using new bearings, the torque to turn value is 20-40 in-lbs.

29. Install the locker indicator switch, use some Teflon thread sealant on the threads

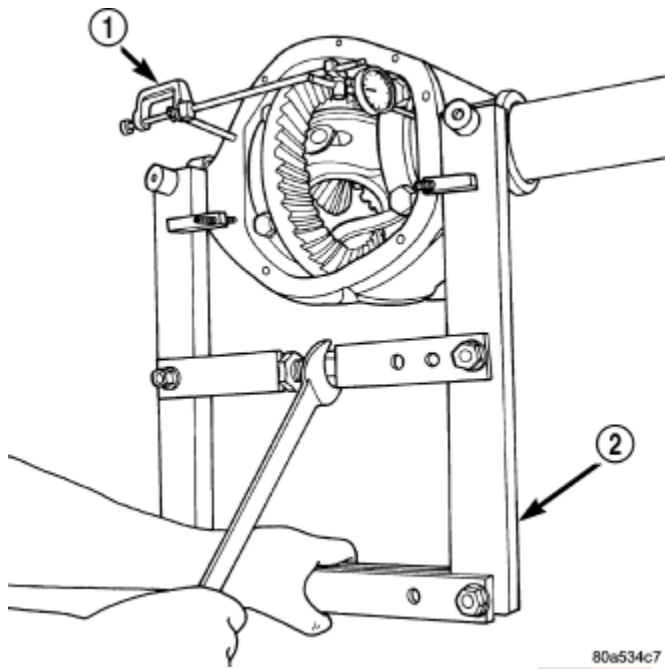

30. We recommend adding a little more carrier bearing preload than what was installed from the factory. Add about .002” to each side carrier bearing shims if you are using the old bearings or add .005” if using new bearings. You may need a housing spreader to install the carrier without damaging the thin shims.

80e534c7

31. Install the carrier and torque the bearing cap bolts to 80 ft-lbs. There is a clearance section on the locker actuating coil to clear locker indicator switch. The coil is in correct position when the coil anti-rotation bracket is aligned with the notch in the coil. Make sure the coil is aligned properly when tightening the bearing cap bolts. If the coil is not aligned correctly you will bend the locker indicator switch and it will not operate correctly. Make sure the head of the locker indicator switch is on the inside of the locker engagement ring. The locker engagement ring moves toward the ring gear and pulls the locker indicator switch out when engaged. The locker will be stuck in the lock position and will not unlock if this is not installed correctly.

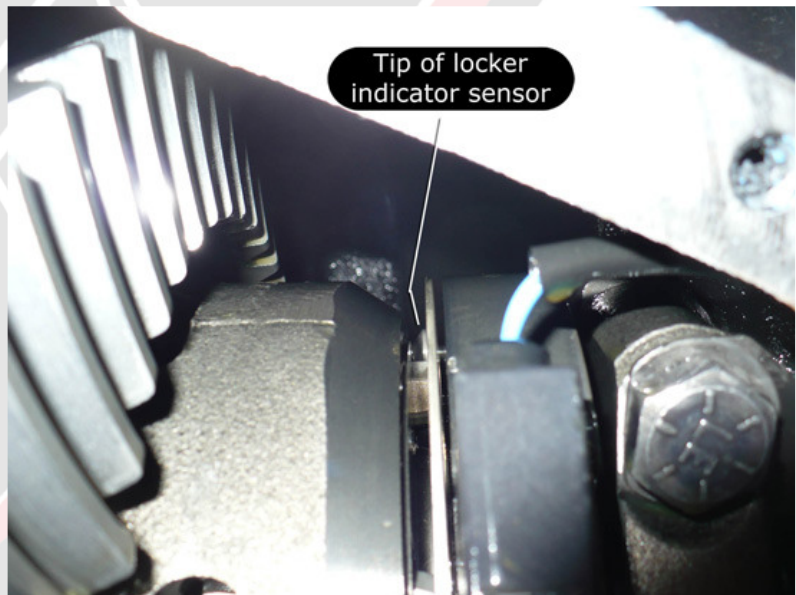
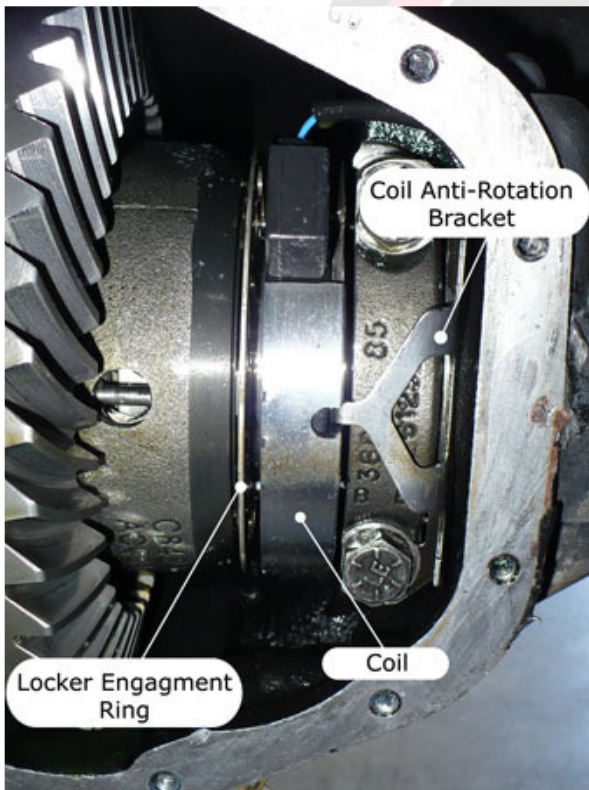

32. Check the backlash and gear contact pattern for a final time.
33. Connect the locker coil wires to the bulkhead connector and install the connector into the diff housing, tighten the bolt to 34-50 in-lbs. Plug in the chassis harness to the bulkhead connector. It is a good idea to verify that the lockers work correctly before you proceed further. Turn the ignition to the on position and put the transfer case in low range and engage the lockers, check that the locker engagement ring moves toward the ring gear and pulls the locker indicator switch out and that the locker disengages correctly.
34. Install the diff cover using the supplied silicone sealant and tighten the bolts to 30 ft-lbs.
35. Install the driveshaft and tighten the bolts to 15 ft-lbs, use thread locker on these bolts.
36. Install axles; torque the 4 axle retaining nuts to 60 ft-lbs, the factory Jeep service manual recommends to not reuse the axle retaining nut, use new ones.
37. Install the ABS sensor in the support plate and torque to 34-50 in-lbs
38. Connect the parking brake cables
39. Install the brake rotors and brake calipers, torque the caliper mounting bracket bolts to 55 ft-lbs.
40. Make sure the differential drain plug is installed and fill with quality 80W-90 gear oil; the factory listed capacity is 4.75 pints.
41. **Ring and Pinion Break-In.** It is critical that you break-in your new gears. Drive the vehicle for 15-20 miles then stop and let the differential cool. Keep the vehicle at speeds below 60 mph for the first 100 miles. Avoid towing or heavy use for the first 500 miles. We also recommend changing the differential fluid after the first 500 miles.

END



© 2009 Poly Performance, Inc.
245 Tank Farm Road, Units L & M, San Luis Obispo, CA 93401
Ph: 805.783.2060 Fax: 805.783.2069
www.polyperformance.com

