

CJ7 / CJ8 SIDESTEPS

Contents:

- M8x30 (4)
- M8x25 (6)
- M8 Flat Washers (10)
- M8 Locking Hex Nuts (10)
- Spacer (4)

1. Use M8x25 hex nuts, flat washers, and locking nuts (use spacers if needed)
2. Use M8x30 hex nuts, flat washers, and locking nuts (use spacers if needed)

Suggested Tools:

- Basic Hand Tools

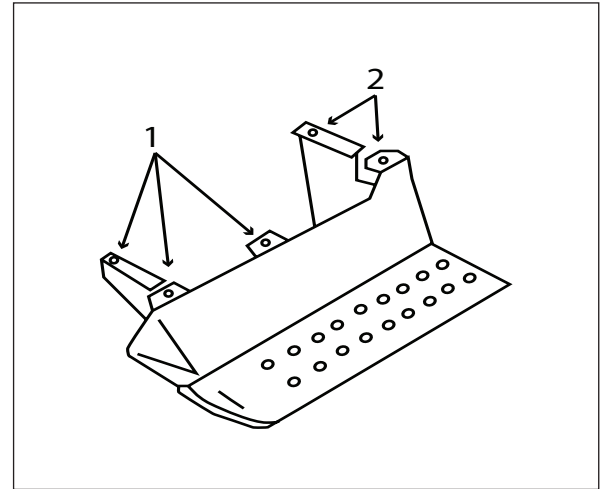

OMIX-ADA® TECHNICAL SUPPORT

PHONE: M-F 8am - 5pm EST 1-800-449-6649 | EMAIL: techsupport@omix-ada.com

FOR WARRANTY INFORMATION VISIT: www.Omix-Ada.com