

FM iPod Adapter

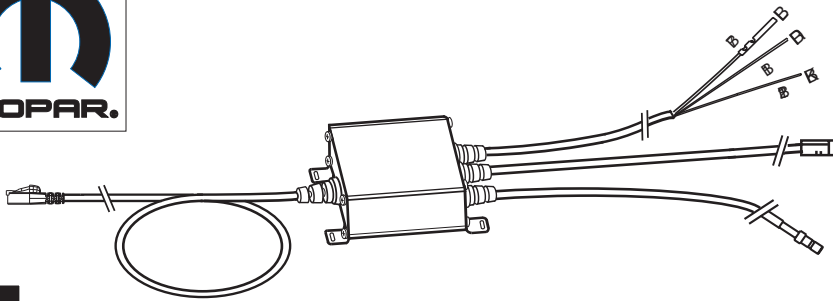

A

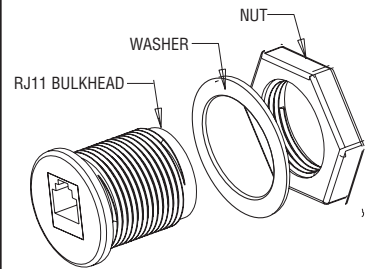

B



C

4X

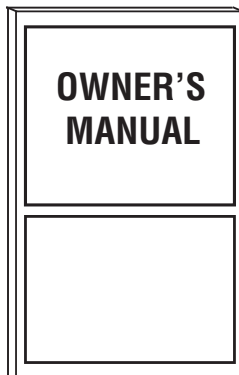

D

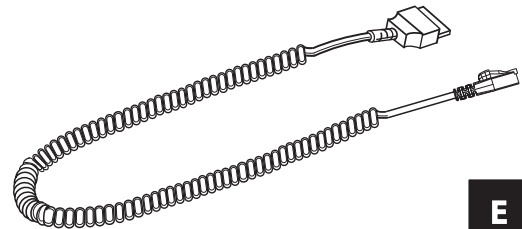

E

INSULATION FOAM PAD



F

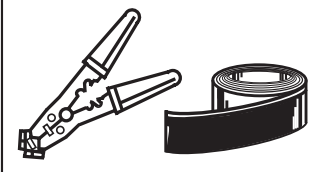
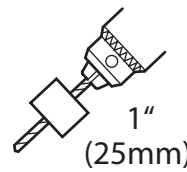
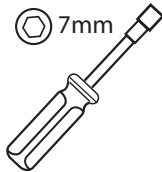
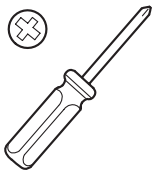

CHRYSLER

ASPEN.....	4,5
TOWN & COUNTRY.....	6,7
SEBRING.....	8,9
300/300C.....	10,11

DODGE

DAKOTA.....	12,13
DURANGO.....	14,15
MAGNUM/CHARGER.....	10,11
CARAVAN.....	6,7
NITRO.....	16,17
AVENGER.....	8,9
JOURNEY.....	18,19
RAM.....	20,21
CHALLENGER.....	22,23
CALIBER.....	24,25

JEEP

COMMANDER XH/XK.....	26,27,28
GRAND CHEROKEE WH.....	29,30
GRAND CHEROKEE WK.....	31,32
LIBERTY.....	16,17
WRANGLER.....	33,34
COMPASS/PATRIOT.....	35,36,37

ELECTRICAL CONNECTIONS

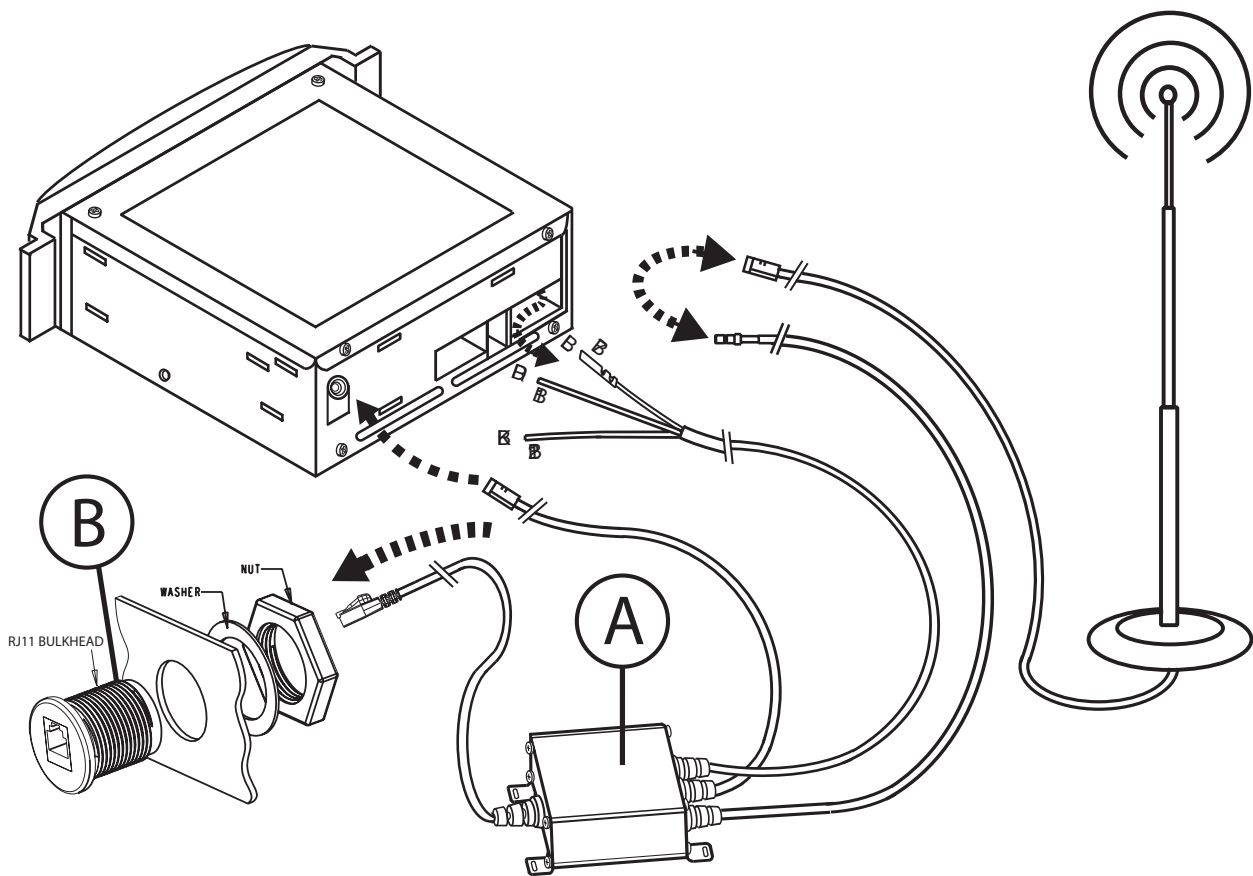

METHOD OF PREPARATION AND INSTALLATION

ELECTRICAL CONNECTIONS

1. Splice red wire from module to a wire from pin 1.
2. Splice black wire from module to a wire from pin 12.
3. If cavity 7 is open, unlock connector and insert blue wire from module with terminal.
4. If cavity 7 is occupied, center splice blue wire from module to the wire from pin 7.

MÉTHODE DE PRÉPARATION ET INSTALLATION CONNEXIONS ÉLECTRIQUES

1. Épissez ou assemblez le câble rouge depuis le module avec un câble du pin 1.
2. Épissez le câble noir depuis le module avec un câble du pin 12.
3. Si la cavité 7 est ouverte, déconnectez le connecteur et insérez le câble bleu du module avec la terminale.
4. Si la cavité 7 est occupée, centrez le câble bleu de l'épissure du module avec le câble du pin 7.

METODO DE PREPARACIÓN E INSTALACIÓN CONEXIONES ELECTRICAS

1. Empalmar el cable rojo del módulo con un cable del pin 1.
2. Empalmar el cable negro del módulo con un cable del pin 12.
3. Si la cavidad 7 esta abierta, desconecte el conector e inserte el cable azul del módulo con la terminal.
4. Si la cavidad 7 está ocupada, centrar el cable azul de empalme del módulo con el cable del pin 7.

METODO DI PREPARAZIONE E INSTALLAZIONE COLLEGAMENTI ELETTRICI

1. Das rote Kabel des Moduls an ein Kabel des Pin 1 anschließen.
2. Das schwarze Kabel des Moduls an ein Kabel des Pin 12 anschließen.
3. Ist der Hohlraum 7 offen, dann den Anschluss ausschließen und das blaue Kabel des Moduls an das Terminal anschließen.
4. Ist der Hohlraum 7 besetzt, dann das blaue Anschlusskabel des Moduls mit dem Kabel des Pin 7 zentrieren.

VORBEREITUNGS- UND EINBAUMETHODE ELEKTRISCHE ANSCHLÜSSE

1. Innestare il cavo rosso del modulo con un cavo del pin 1.
2. Innestare il cavo nero del modulo con un cavo del pin 12.
3. Se la cavità 7 è aperta, disinserire il conettore ed inserire il cavo azzurro del modulo con la terminale.
4. Se la cavità 7 è occupata, centrare il cavo azzurro della giuntura del modulo con il cavo del pin 7.

WIJZE VAN VOORBEREIDING EN INSTALLATIE ELEKTRISCHE CONNECTIES

1. Verbind de rode kabel van de module met een kabel van pin 1.
2. Verbind de zwarte kabel van de module met een kabel van pin 12.
3. Indien holte 7 vrij is, koppel het verbindingsstuk los en plaats de blauwe kabel van de module in het apparaat.
4. Indien holte 7 bezet is, verbind de blauwe verbindingskabel van de module met de kabel van pin 7.

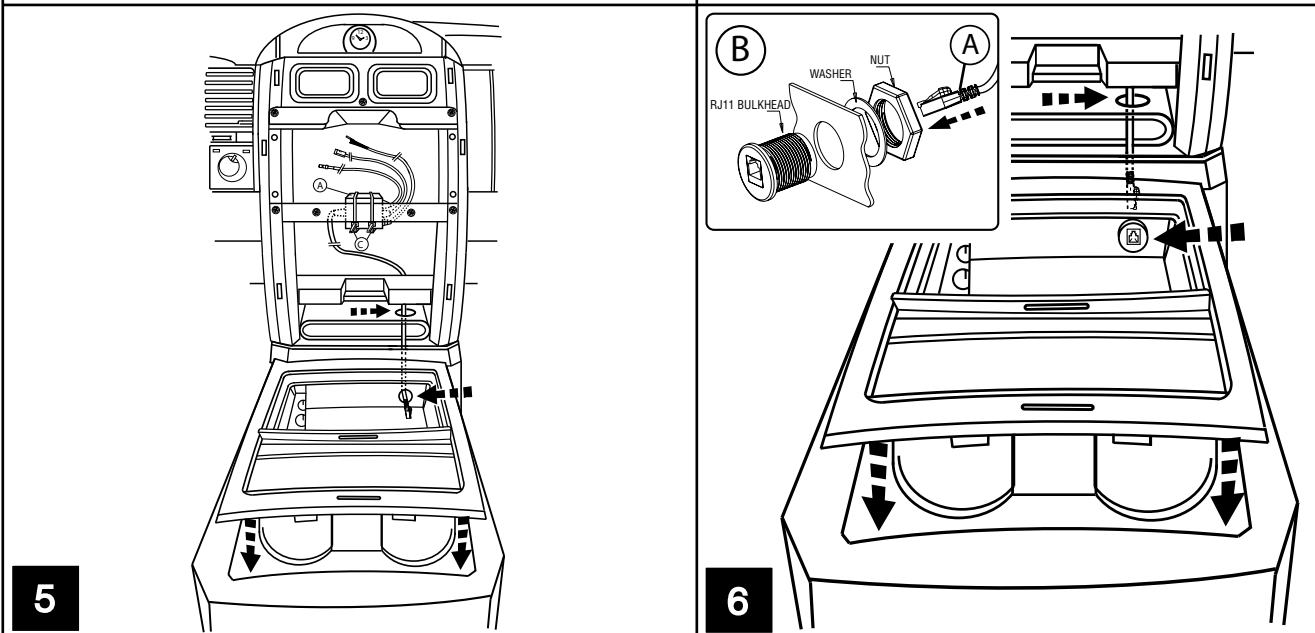
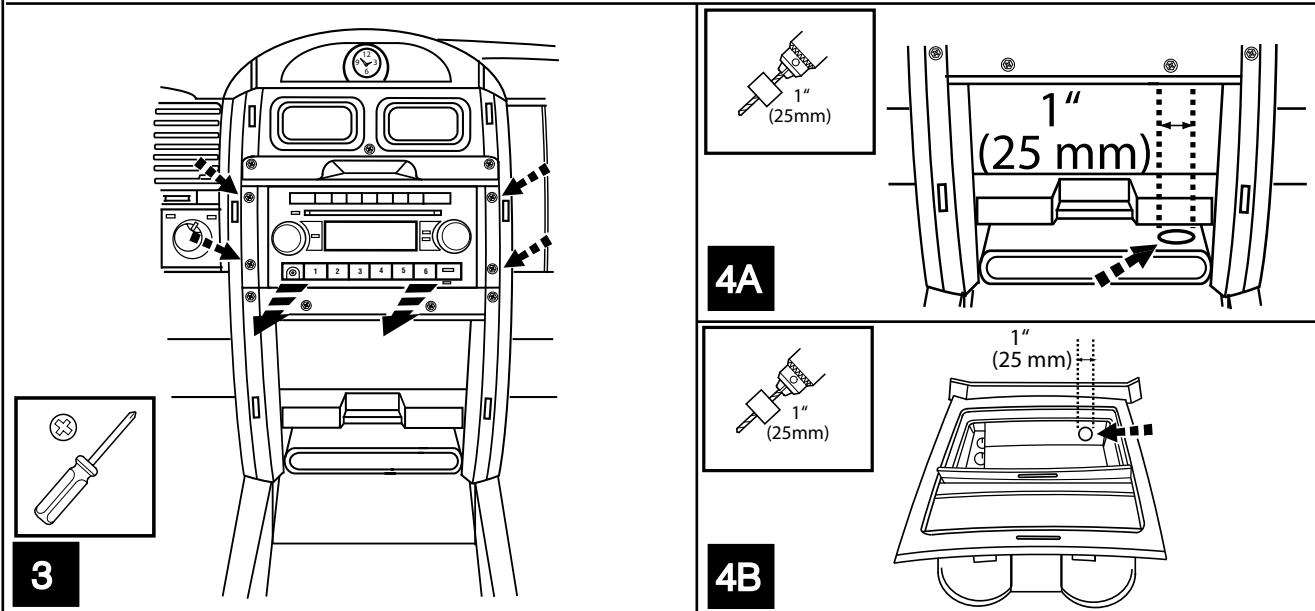
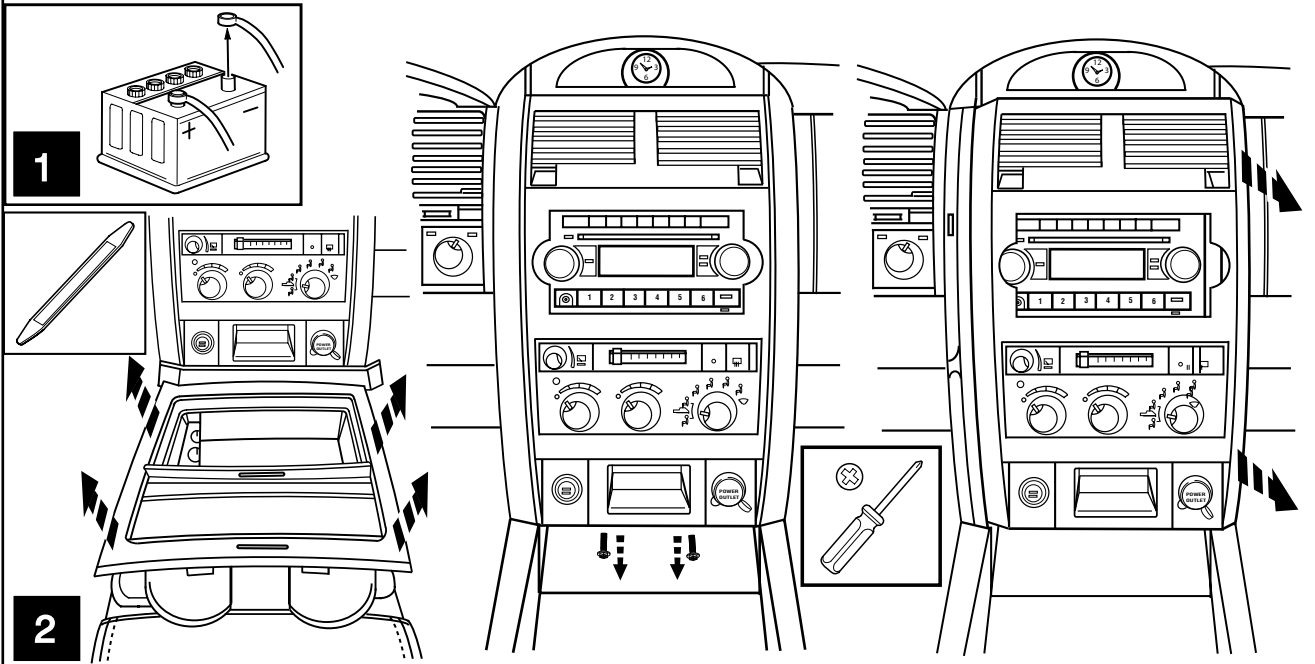

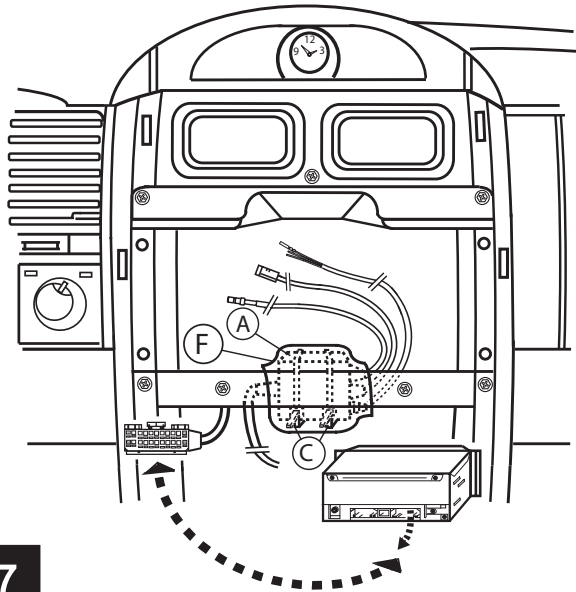

7

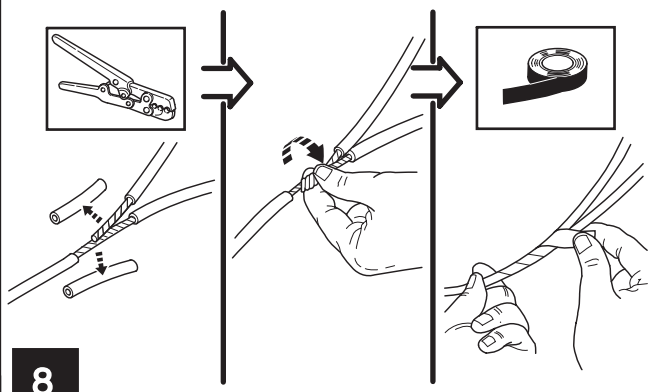
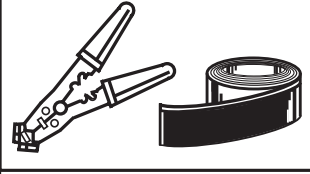

8

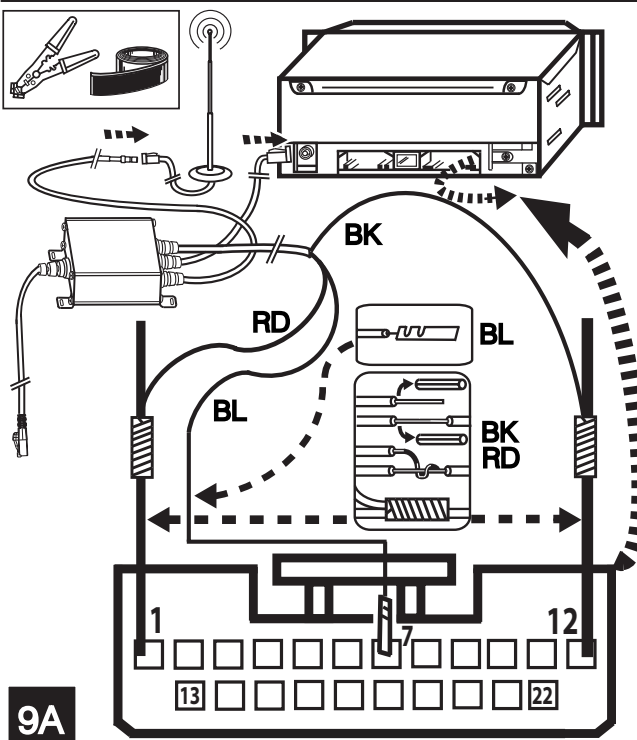

9A

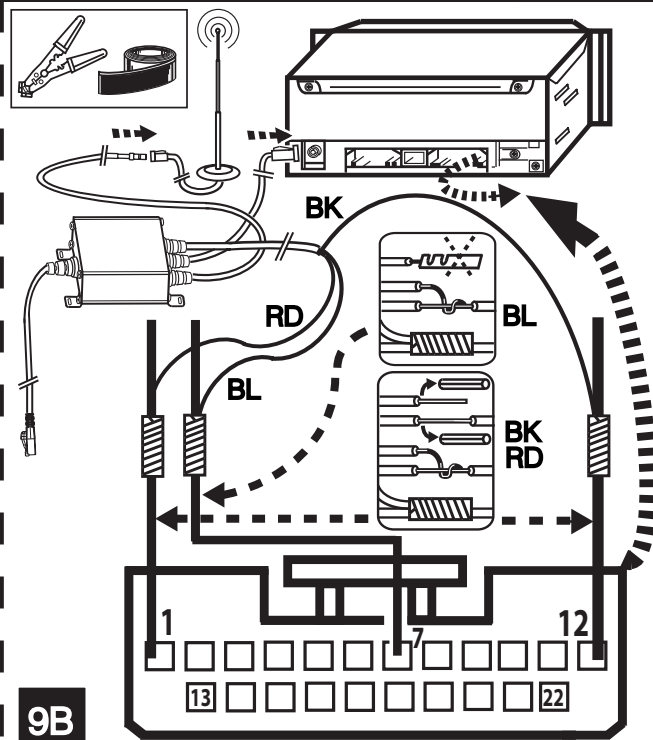

9B

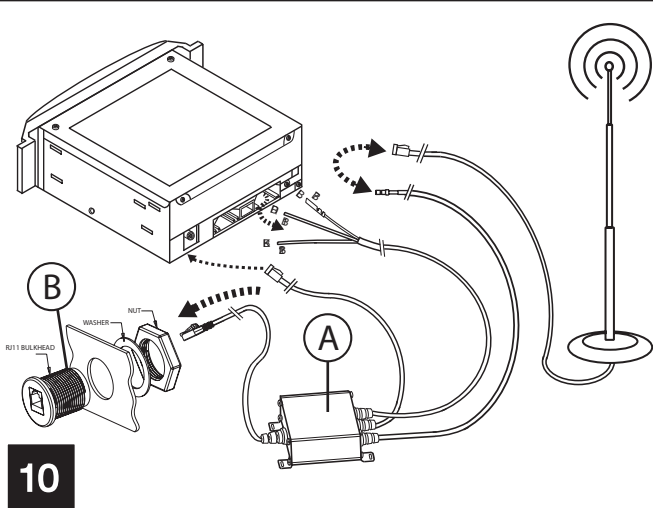

10

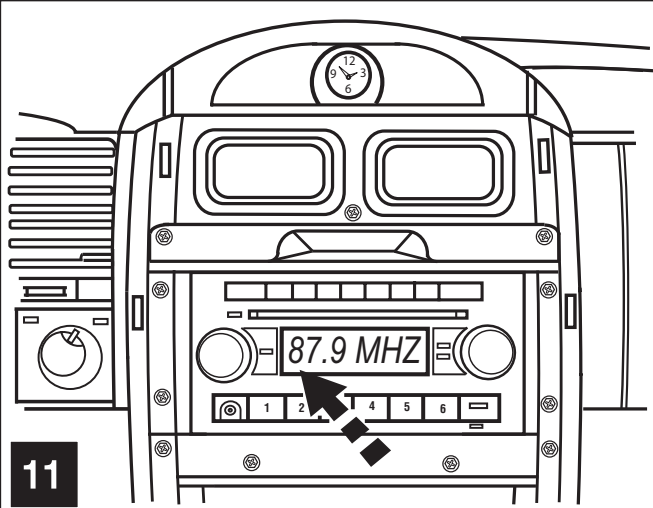

11

CARAVAN/TOWN & COUNTRY

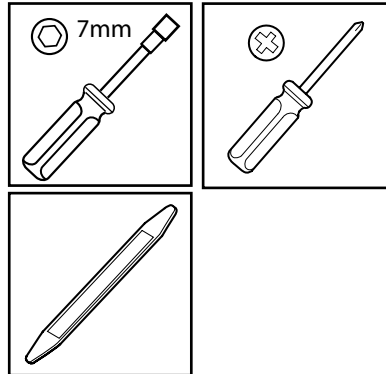
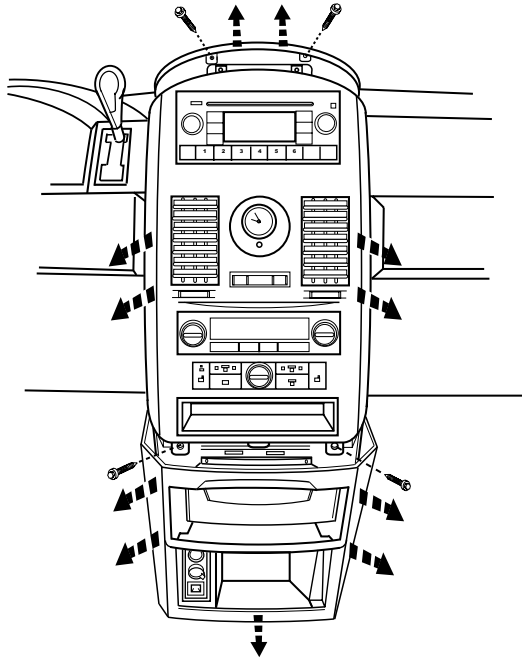
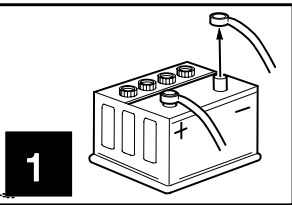

2

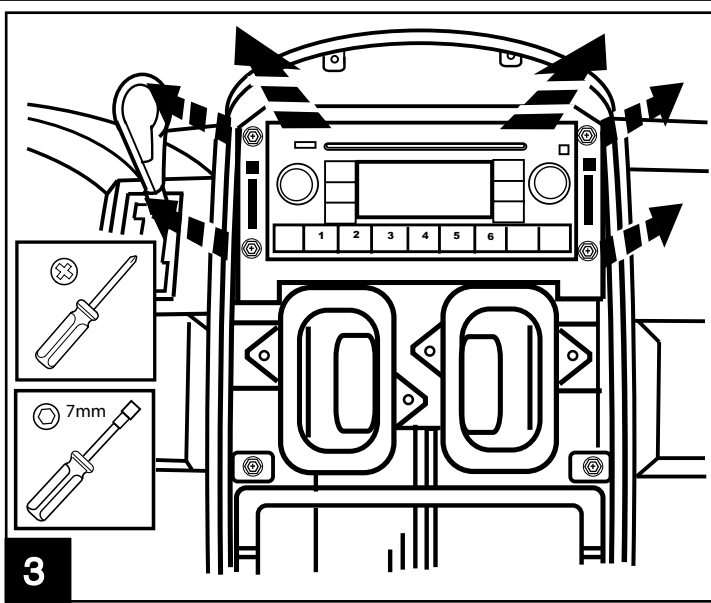

3

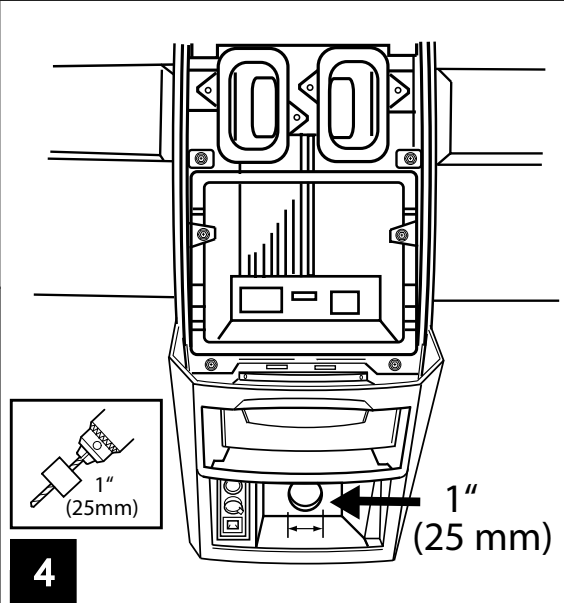

4

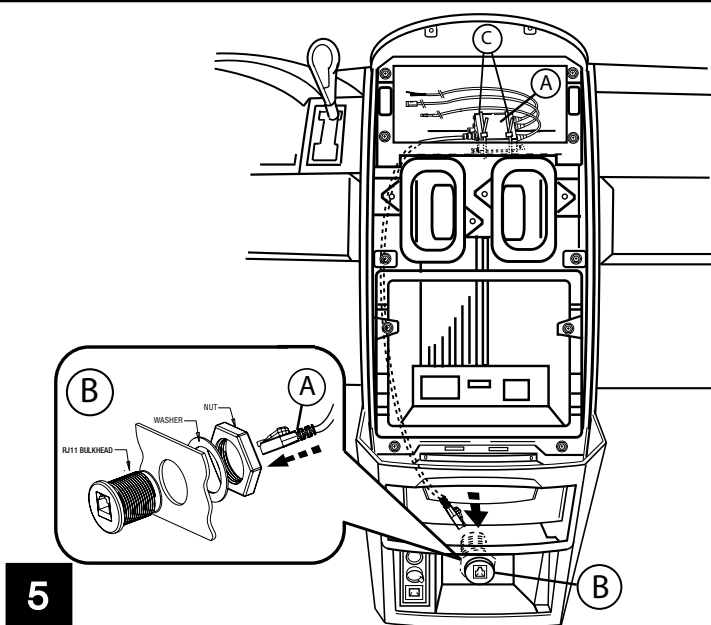

5

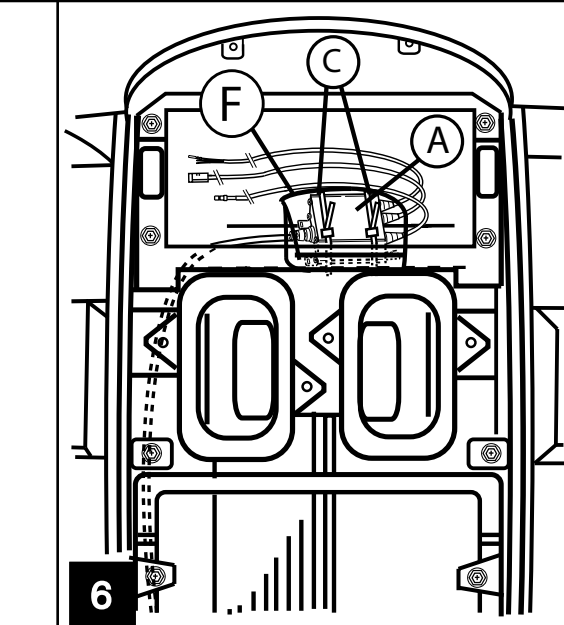

6

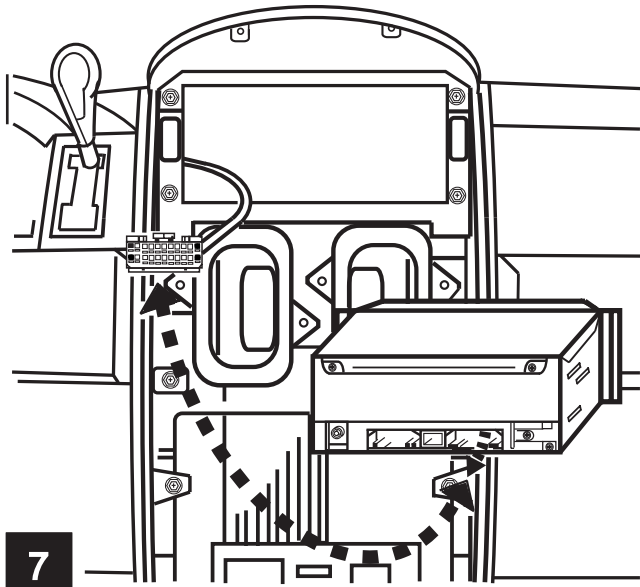

7

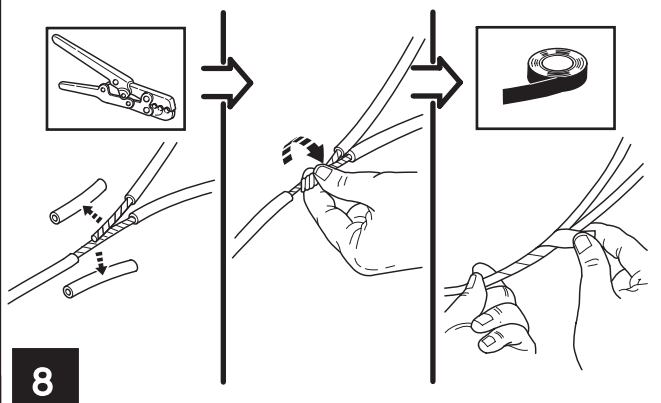
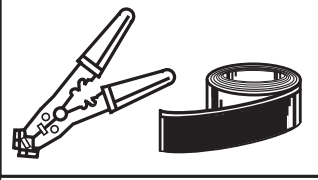

8

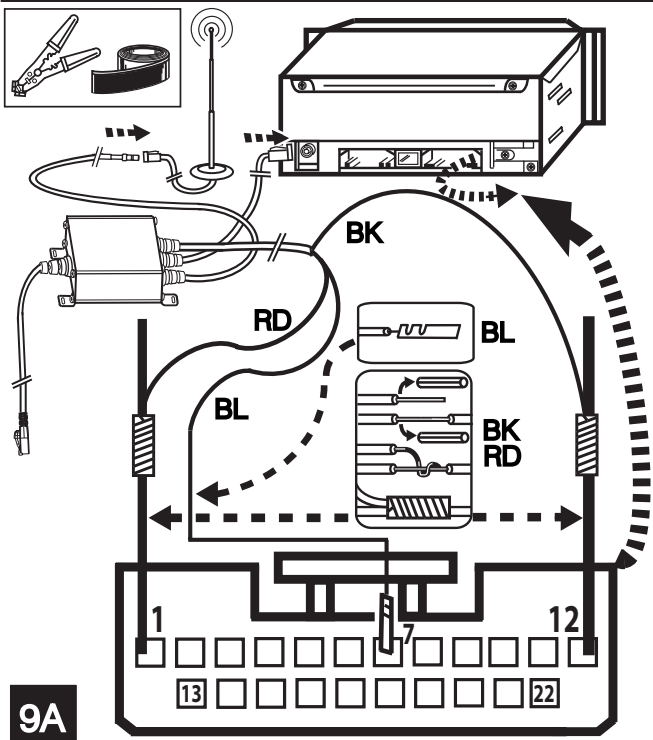

9A

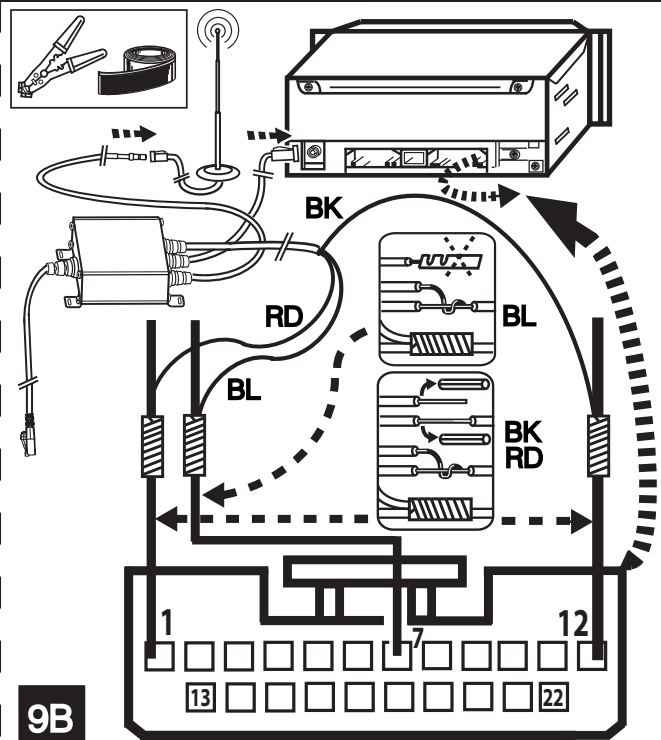

9B

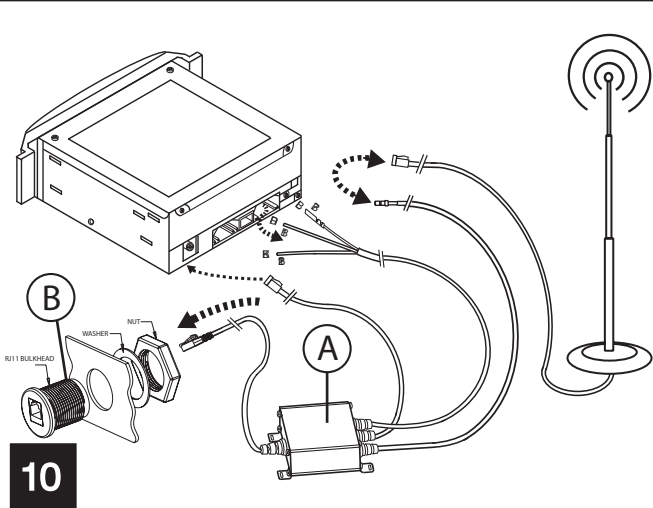

10

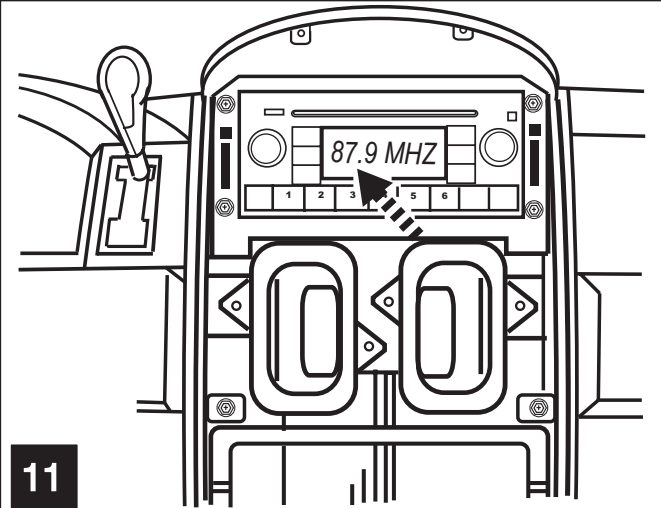

11

SEBRING/AVENGER

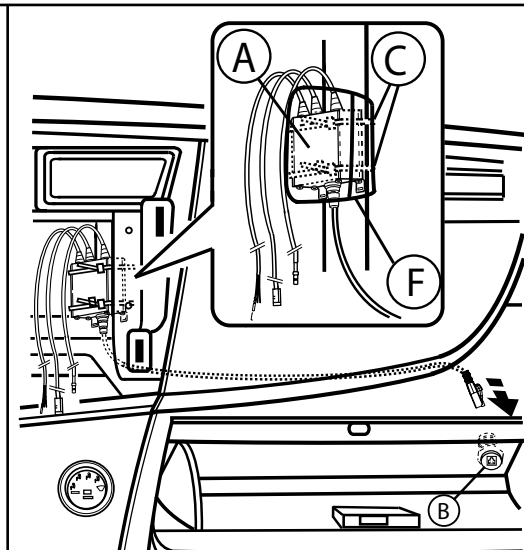
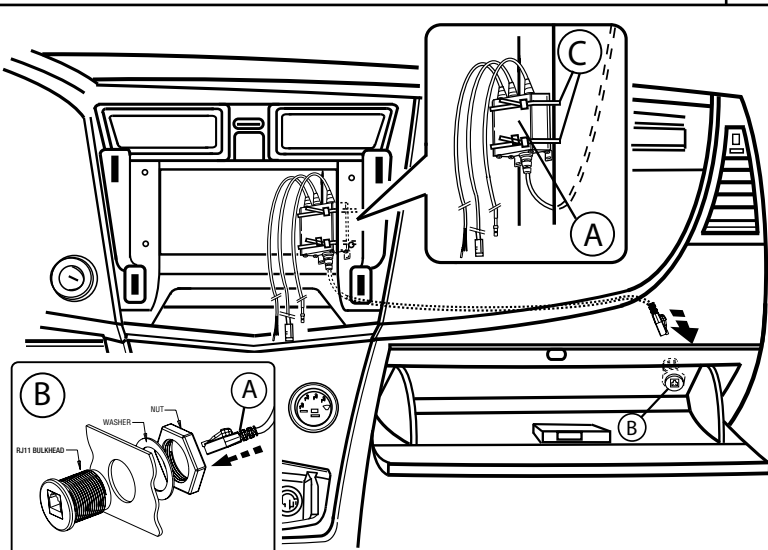
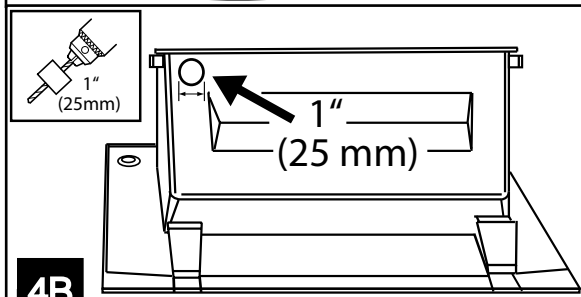
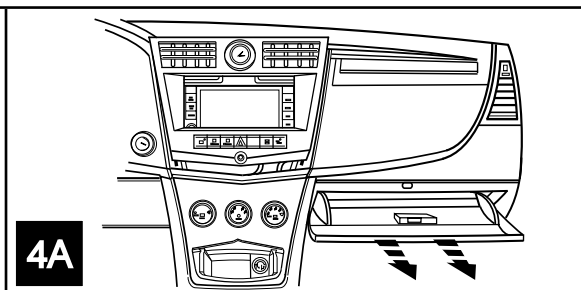
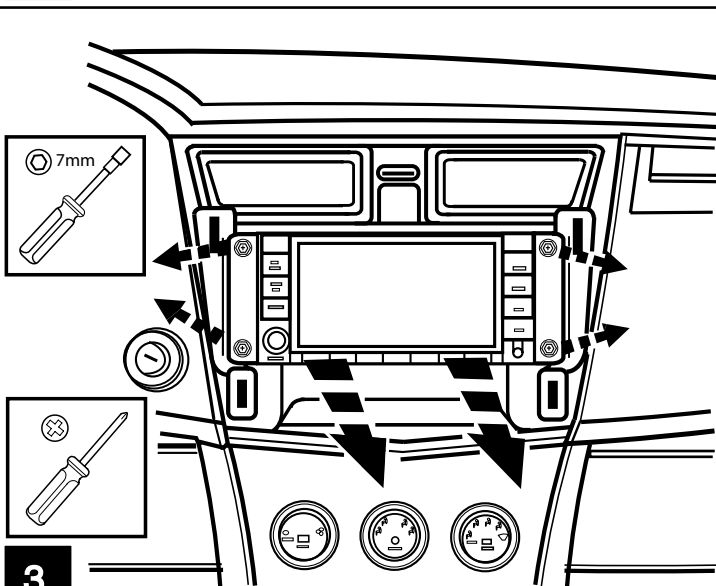
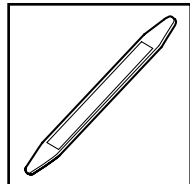
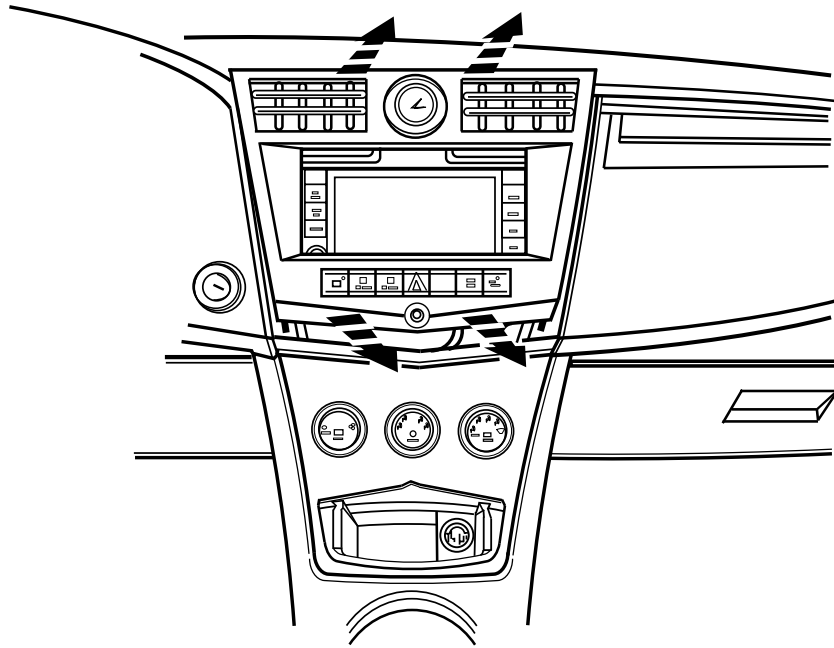
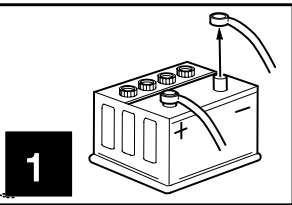

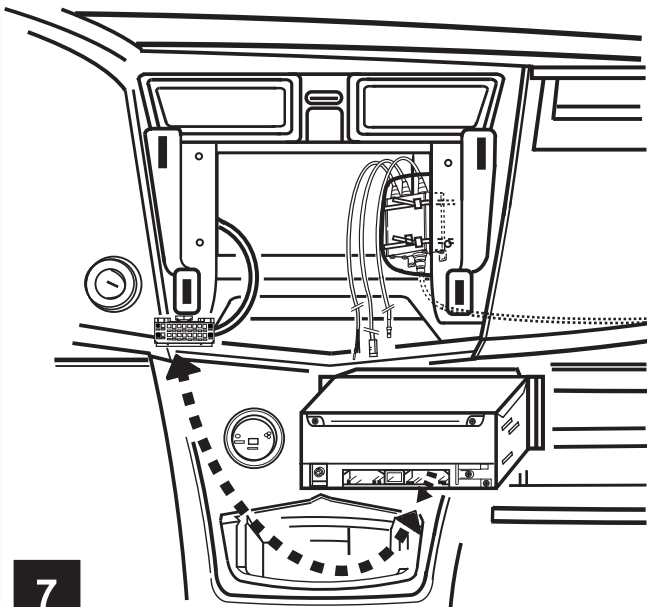

7

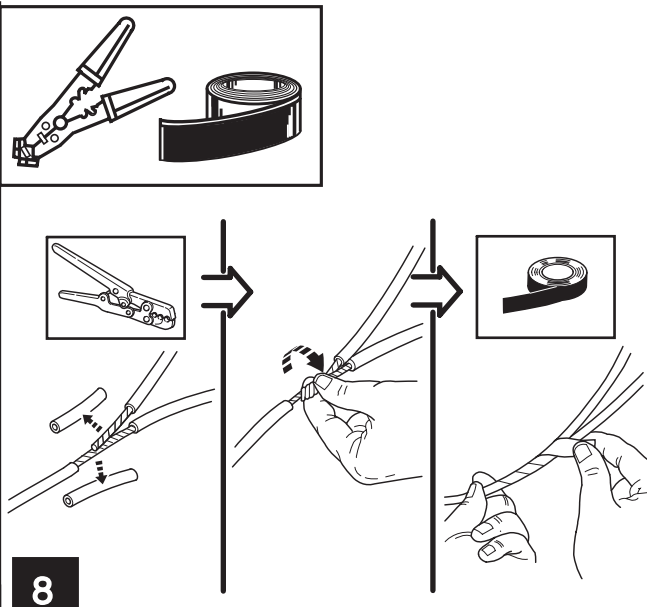

8

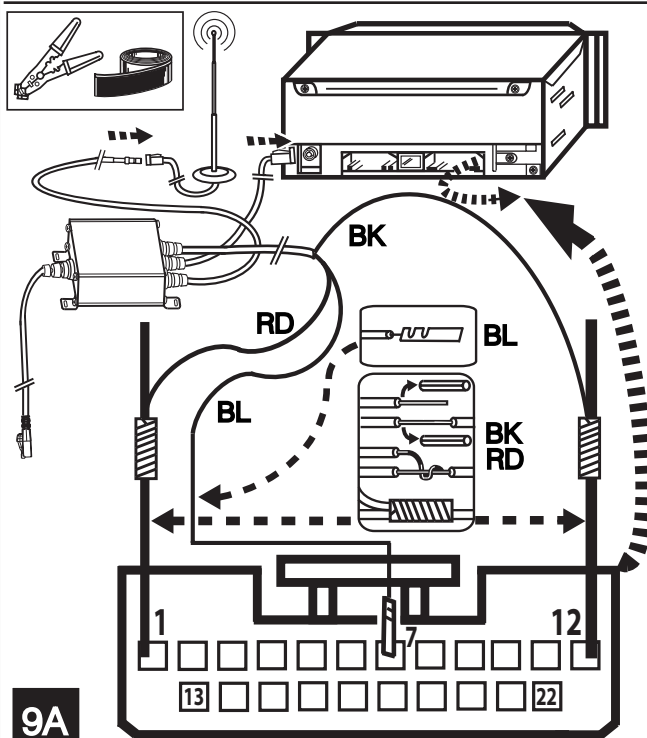

9A

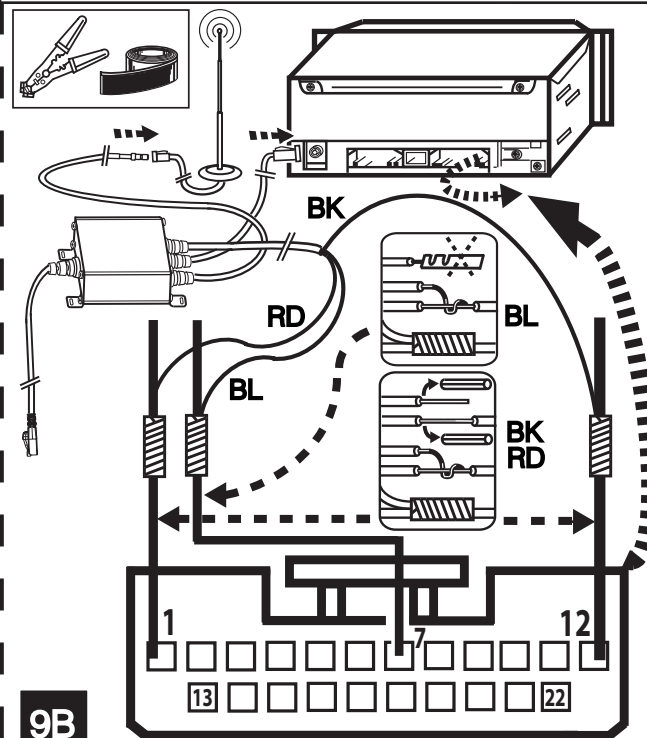

9B

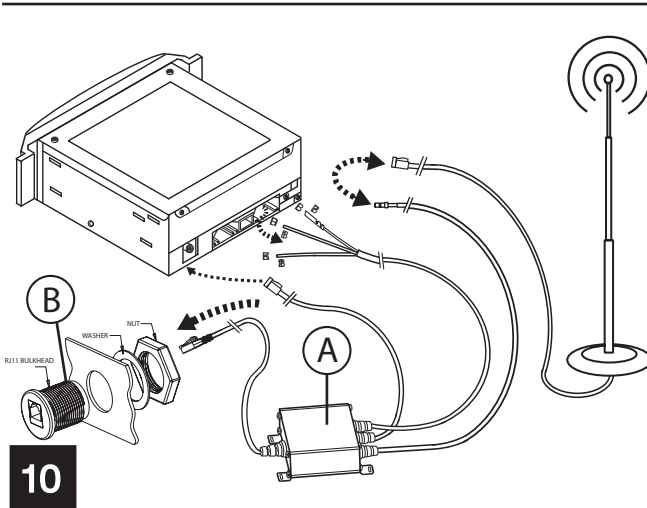

10

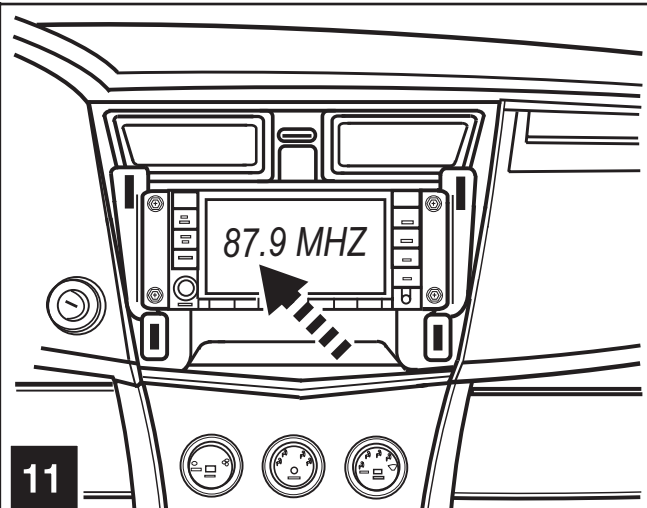

11

300/300C/MAGNUM/CHARGER

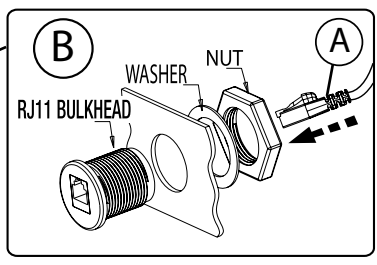
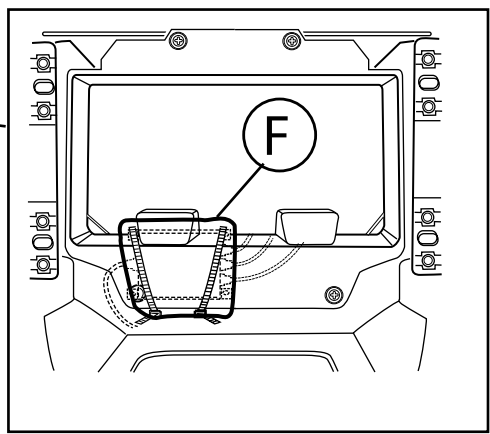
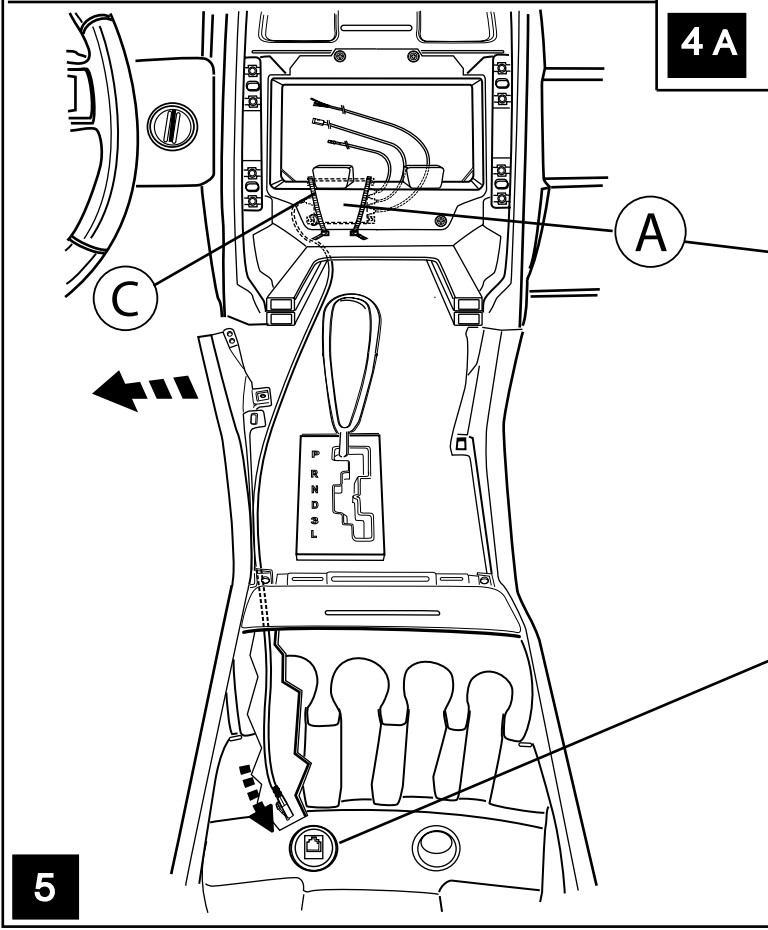
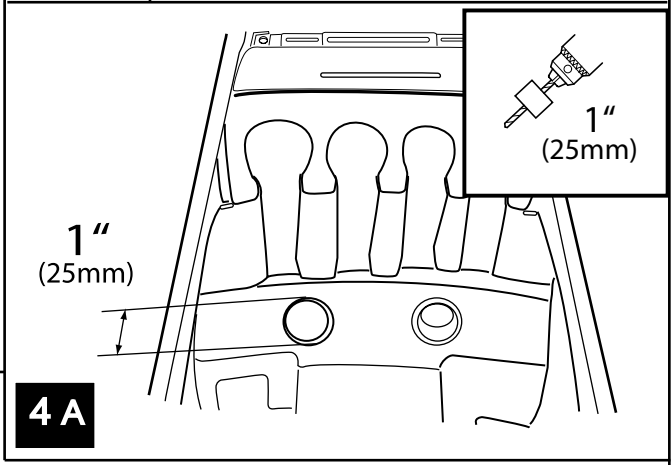
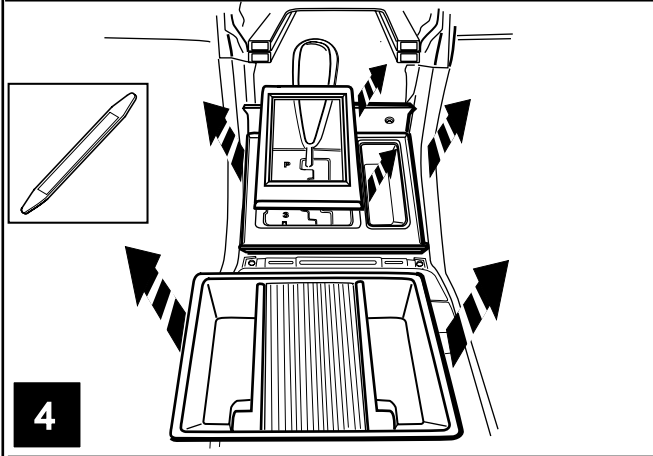
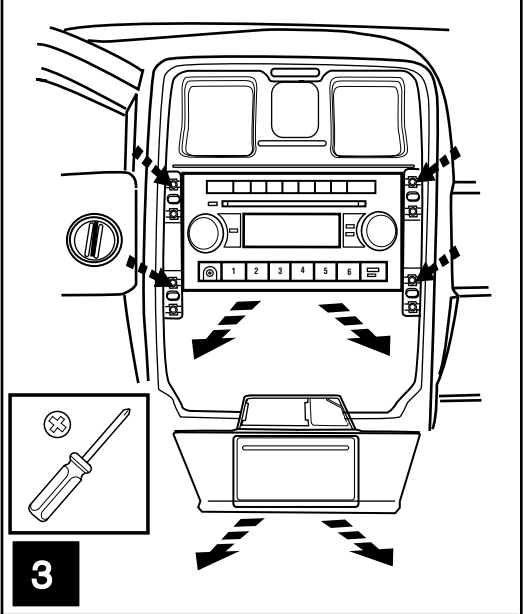
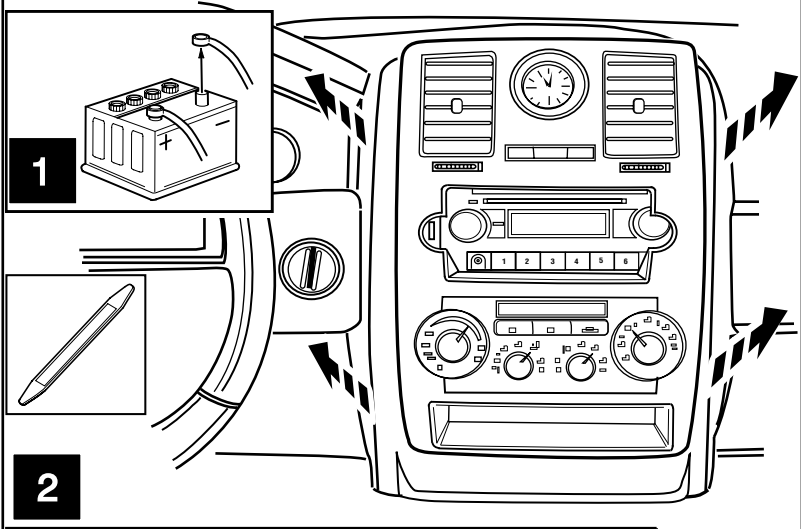

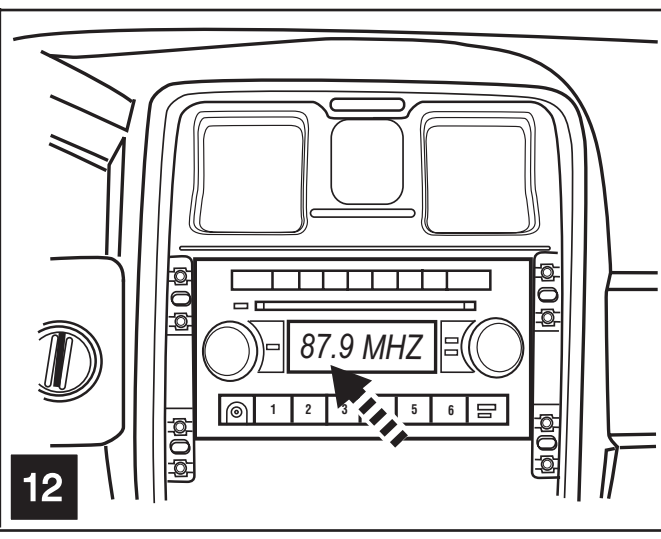
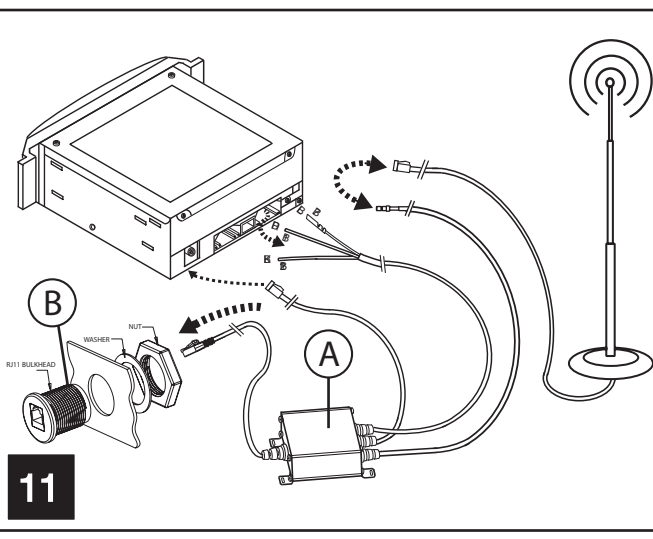
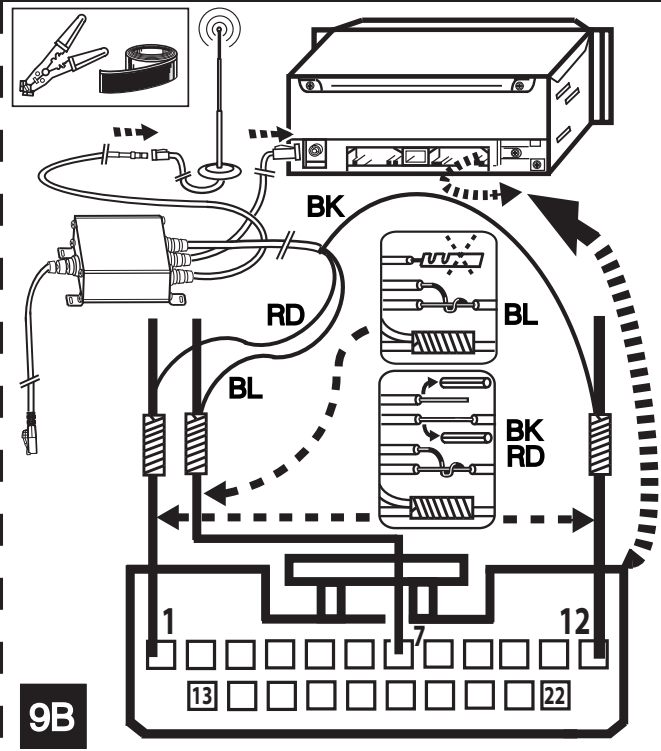
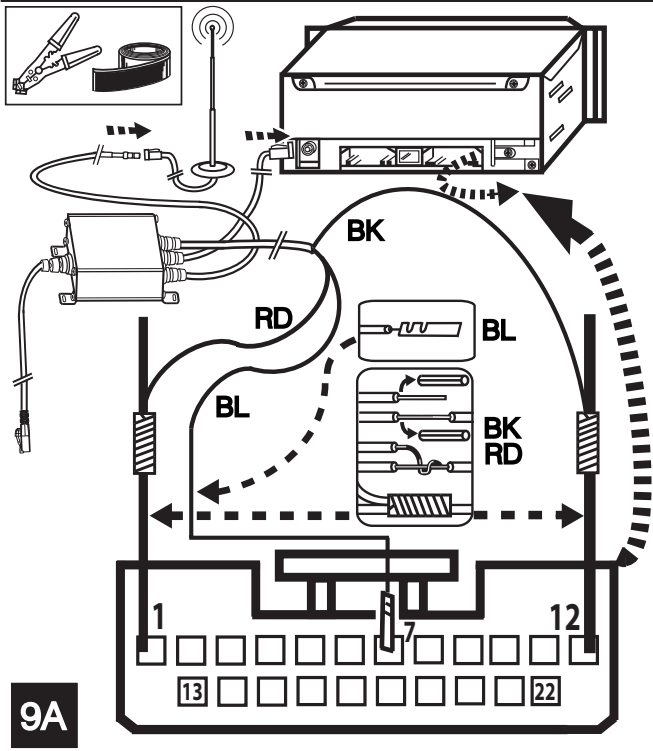
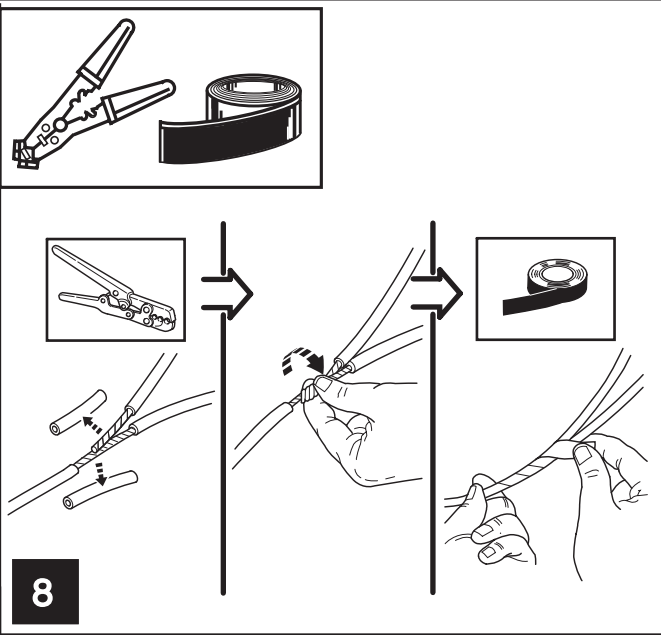
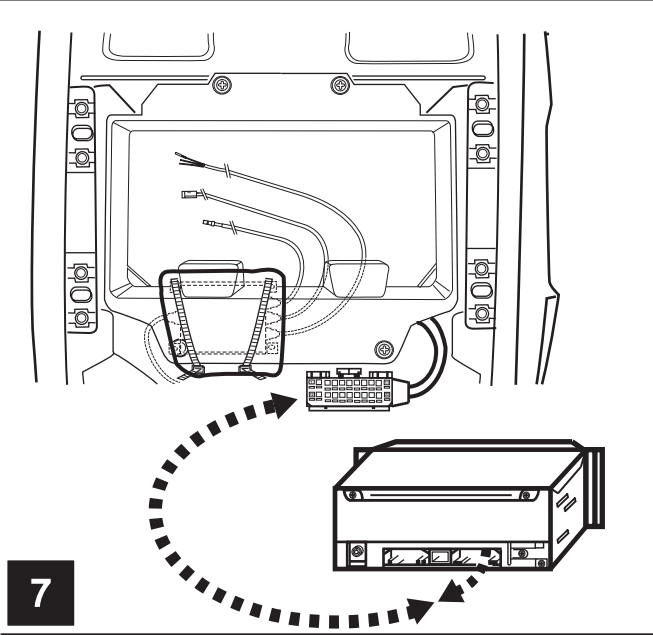

1

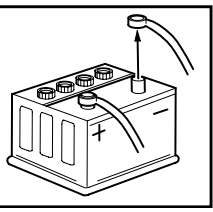

2

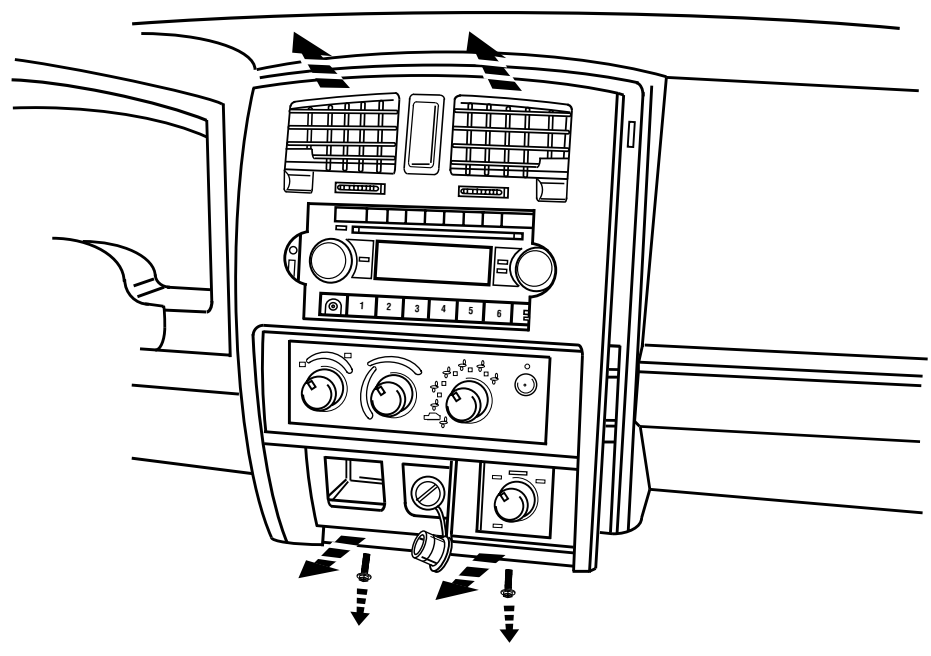
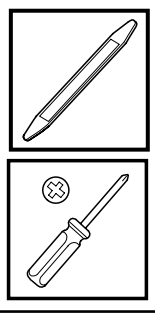

3

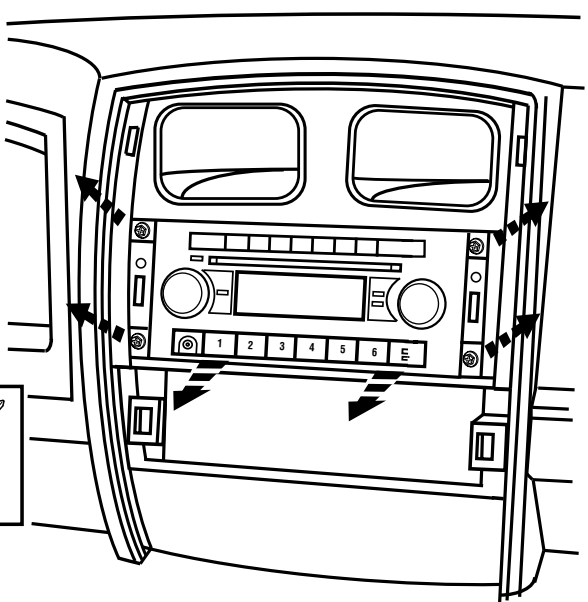
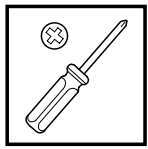

4A

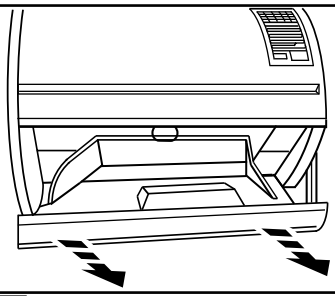

4B

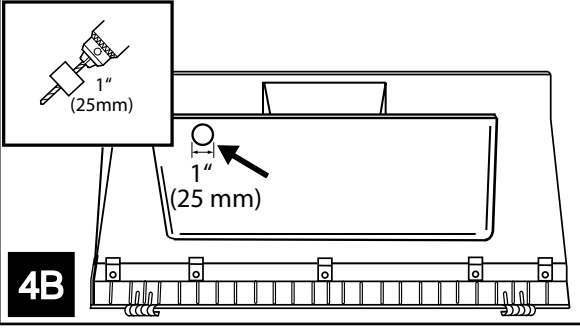

5

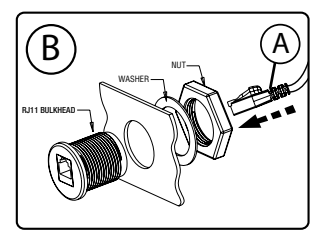
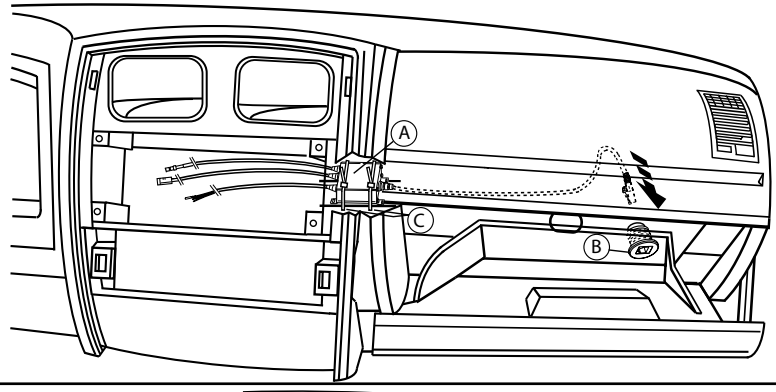

6

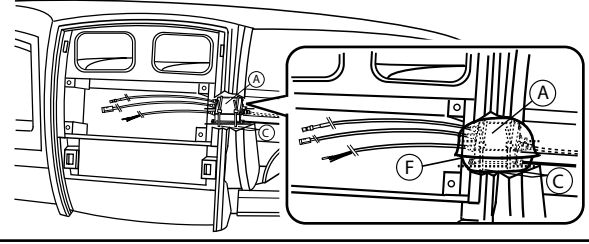

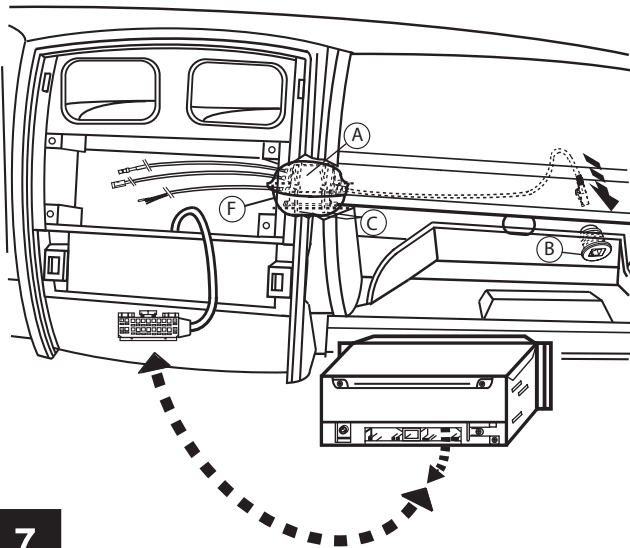

7

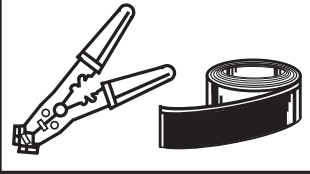

8

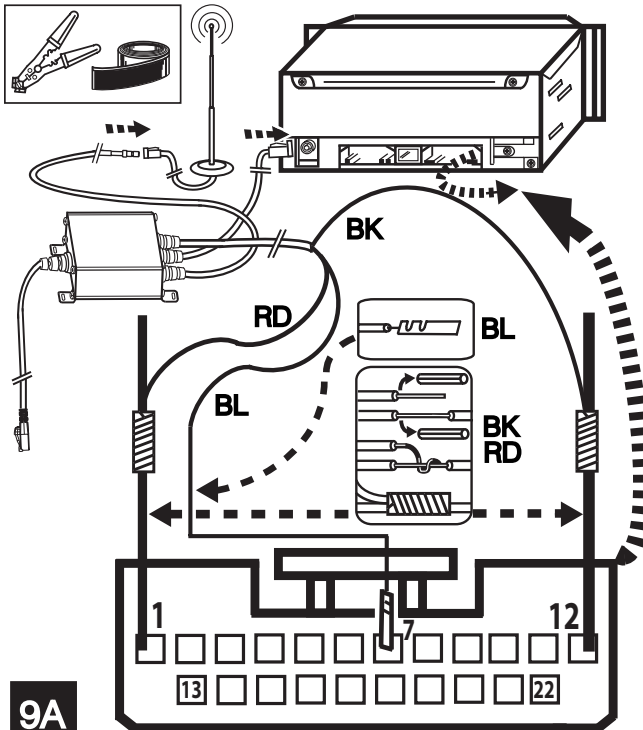

9A

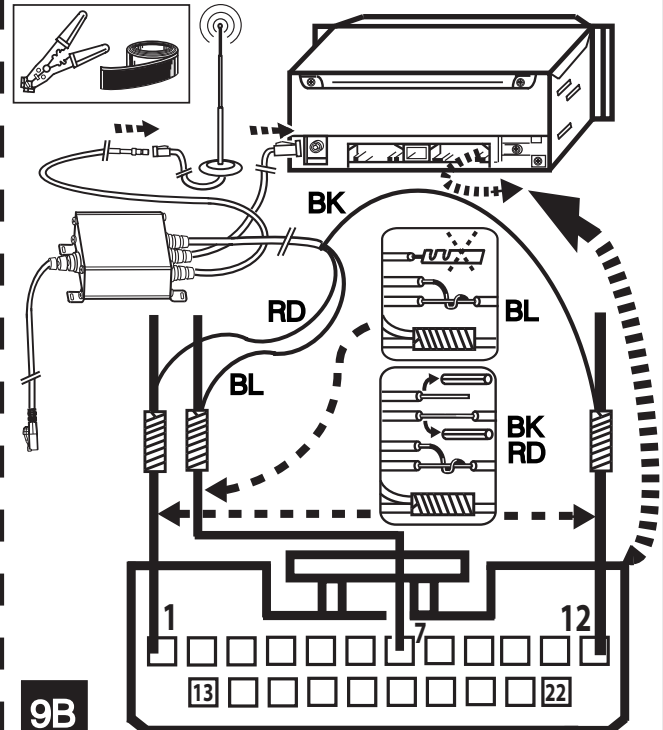

9B

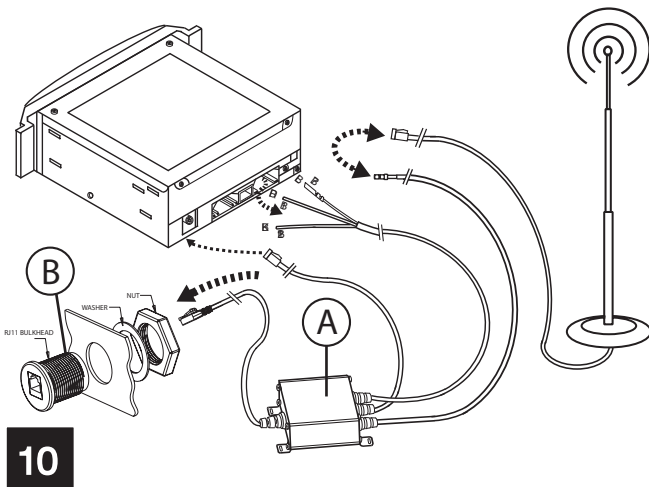

10

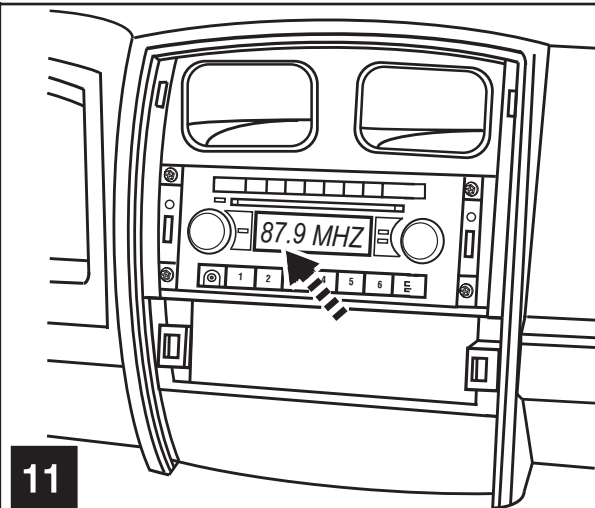

11

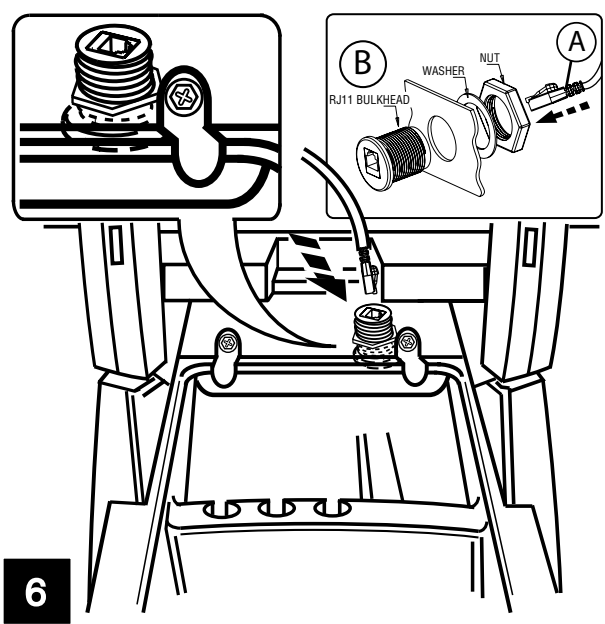
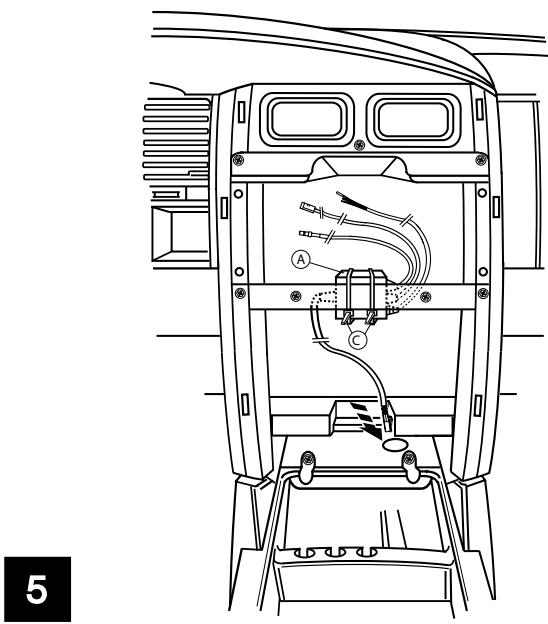
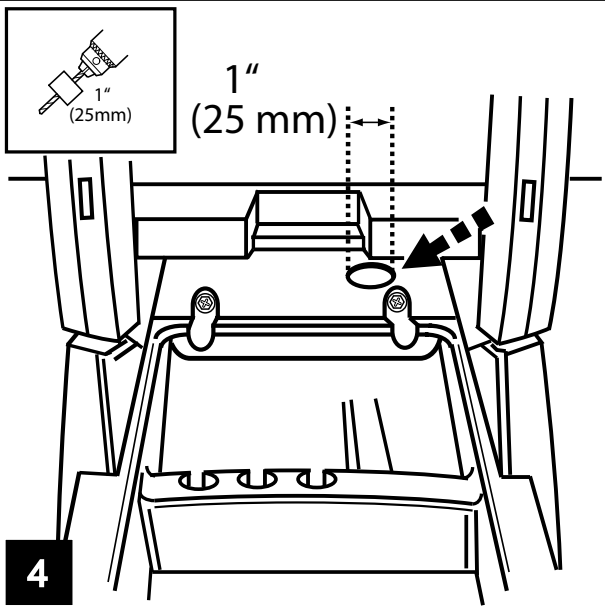
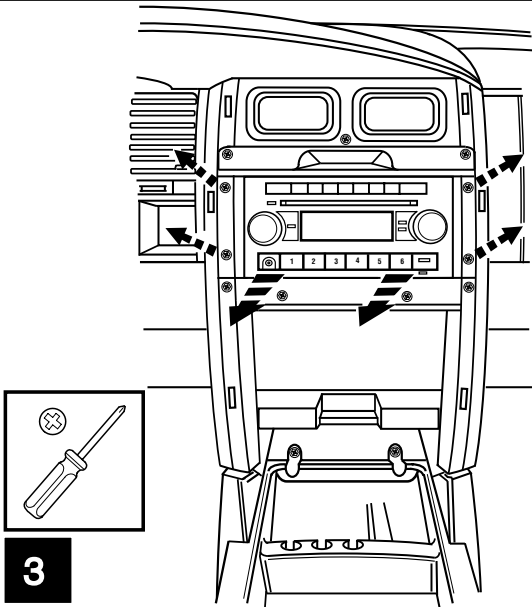
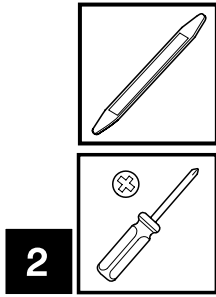
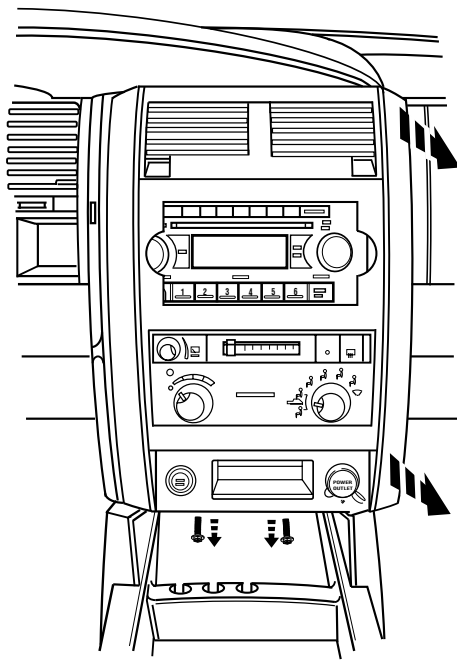
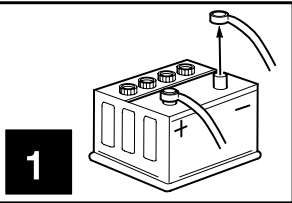

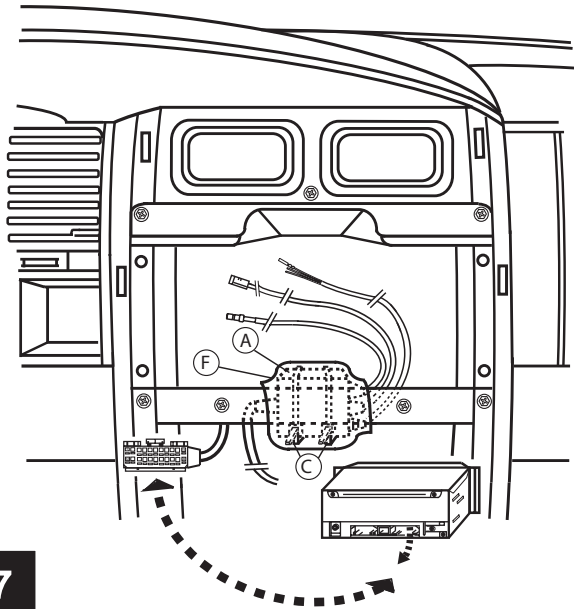

7

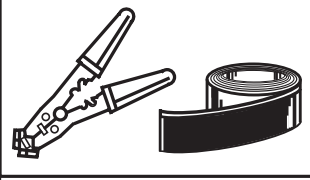

8

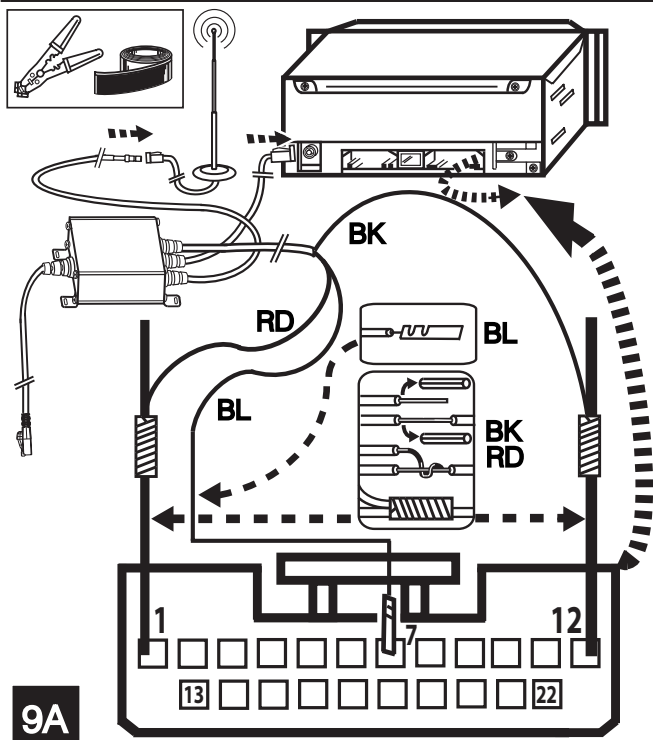

9A

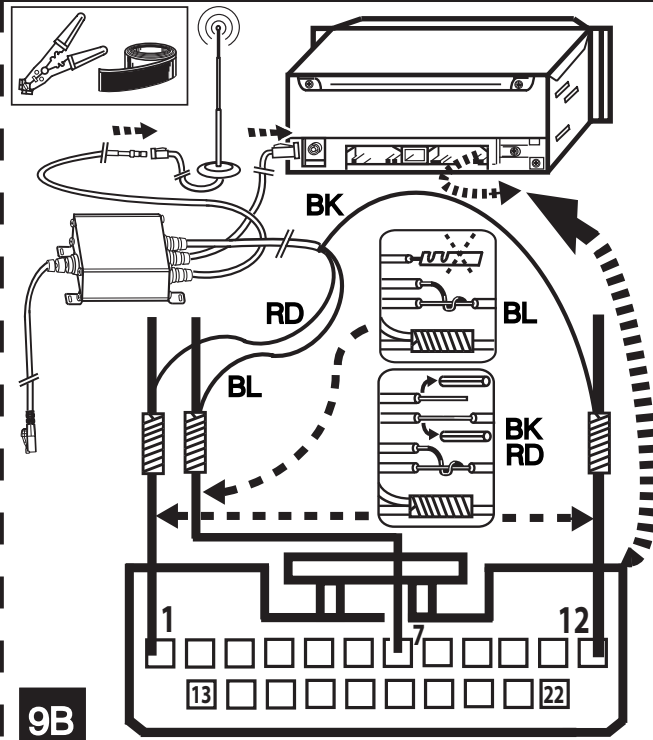

9B

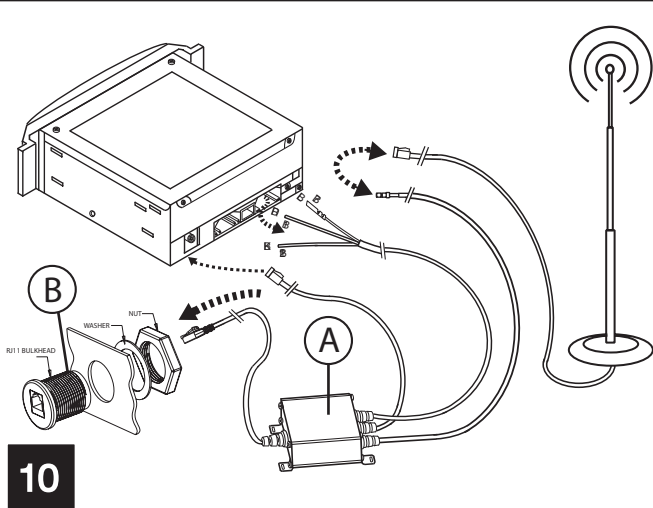

10

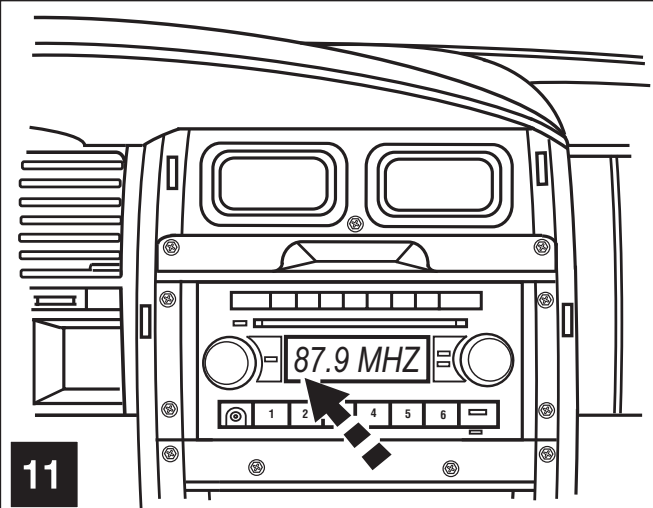

11

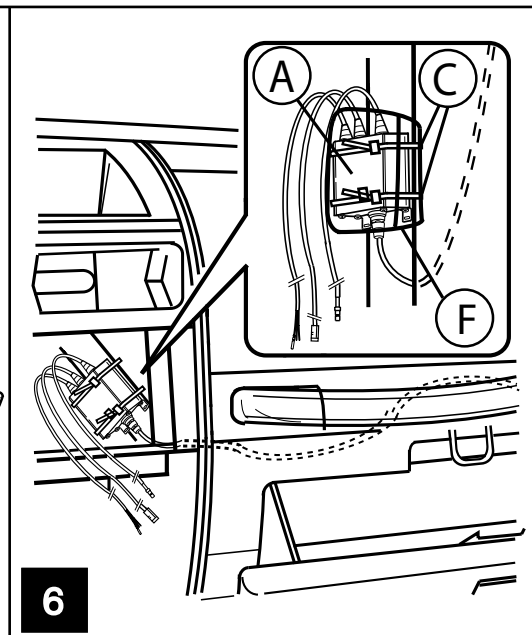
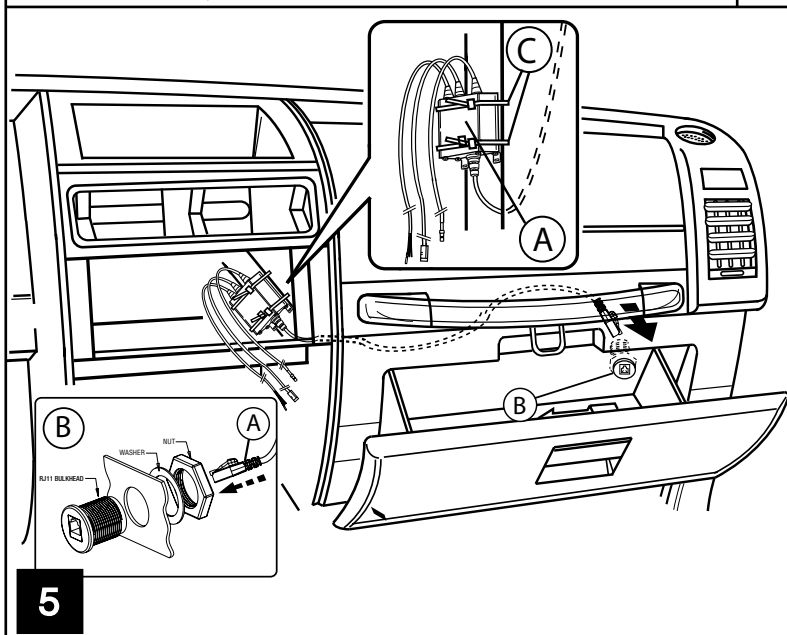
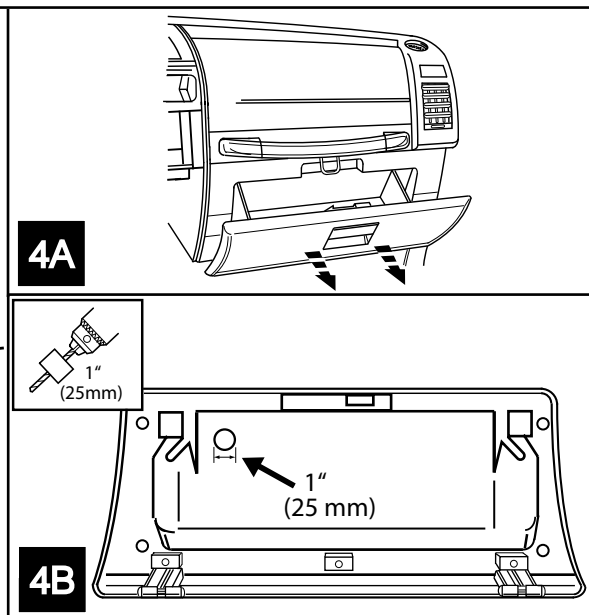
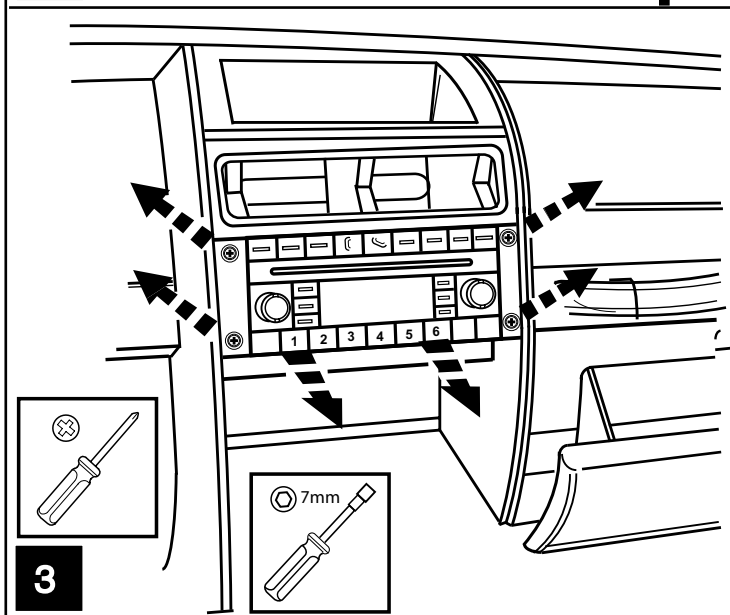
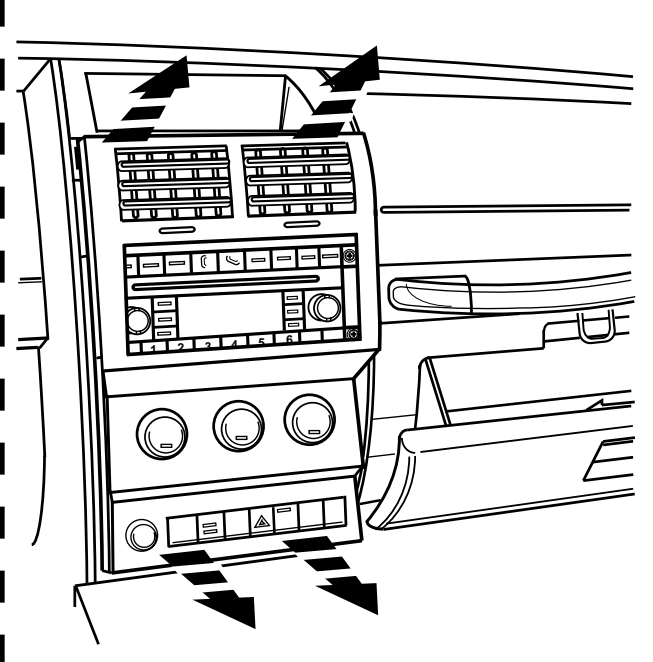
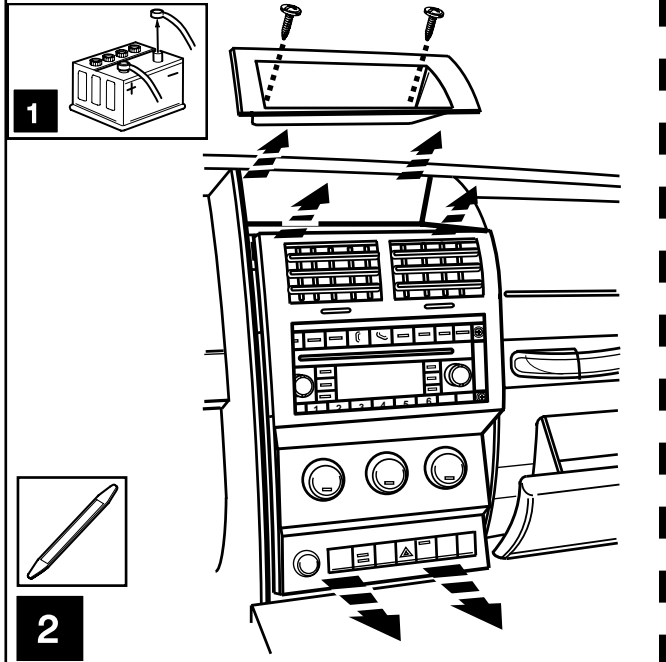

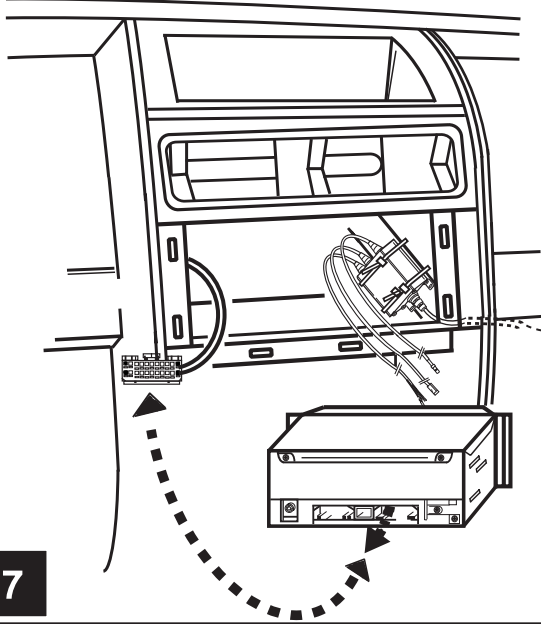

7

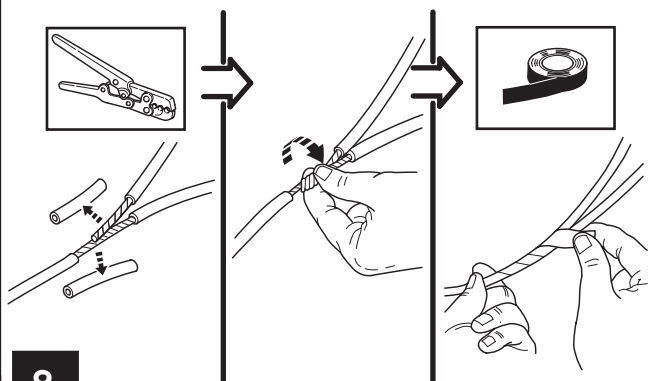
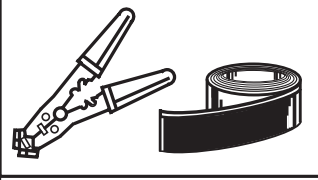

8

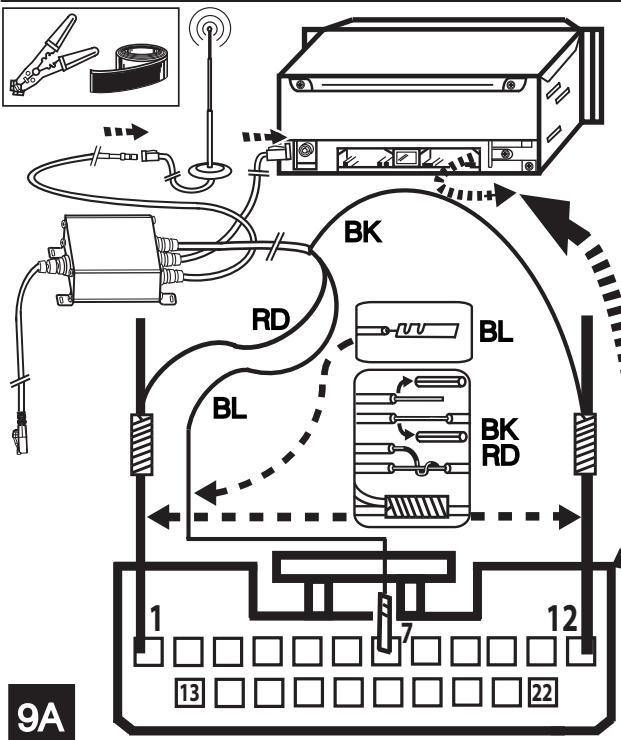

9A

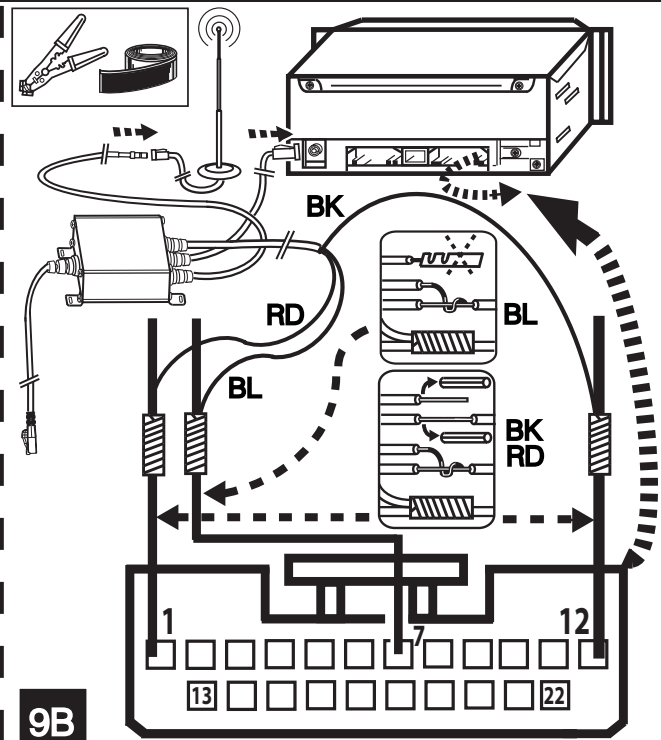

9B

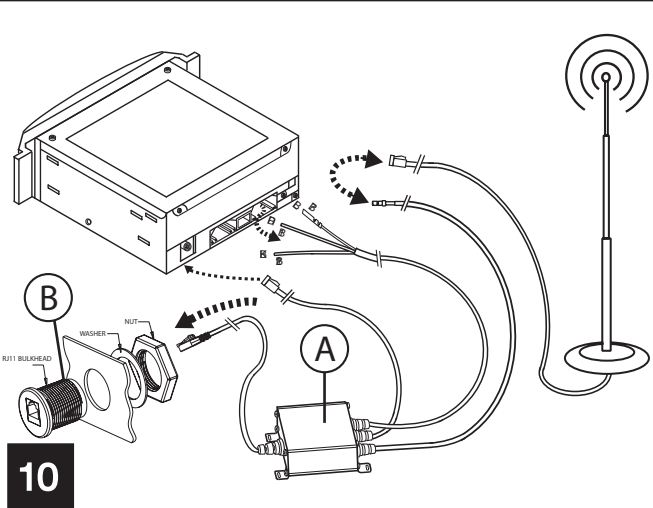

10

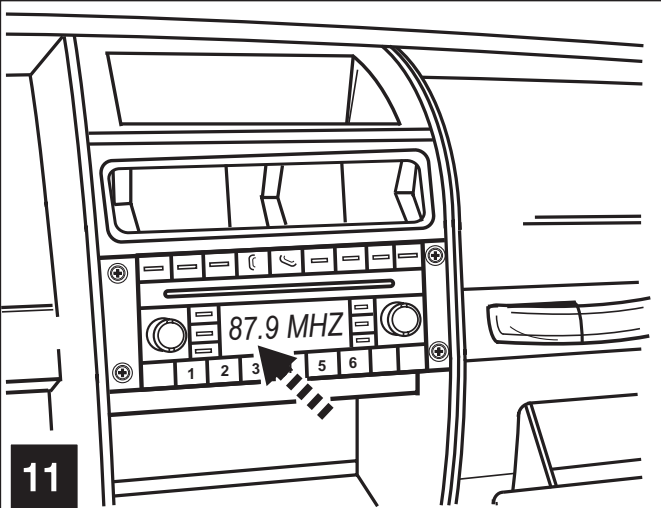

11

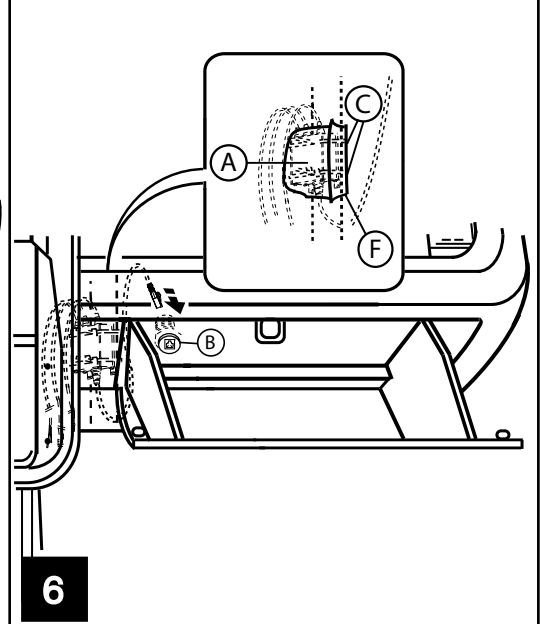
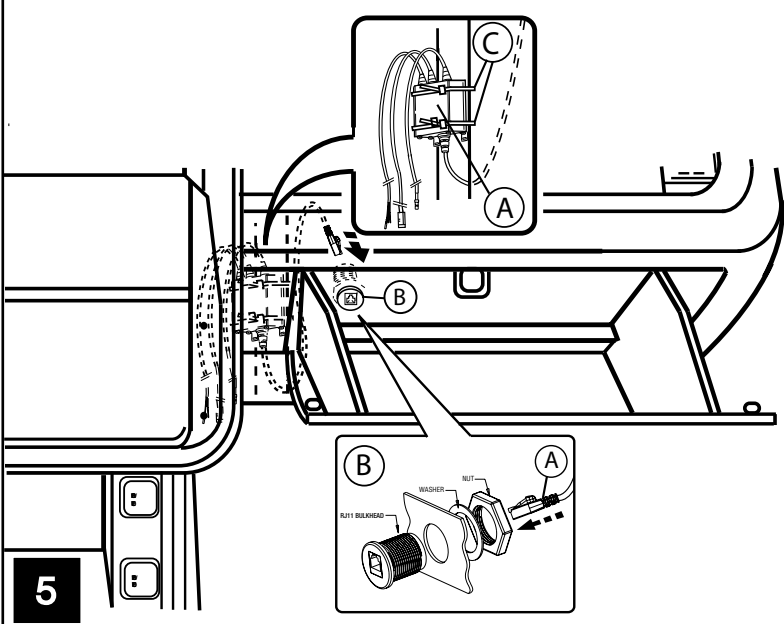
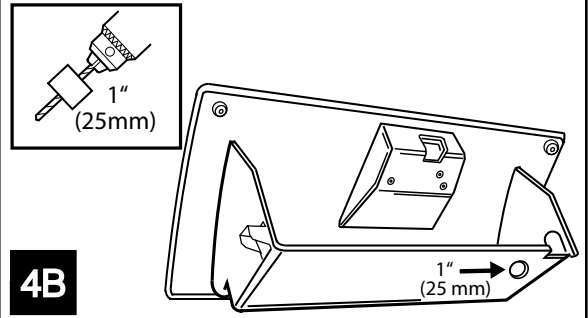
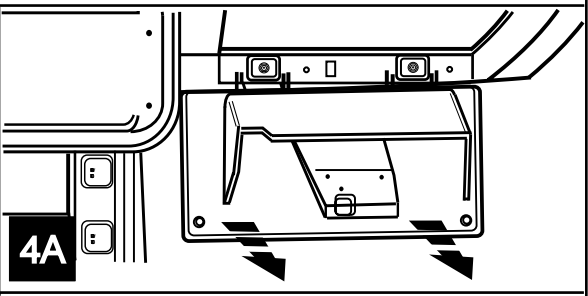
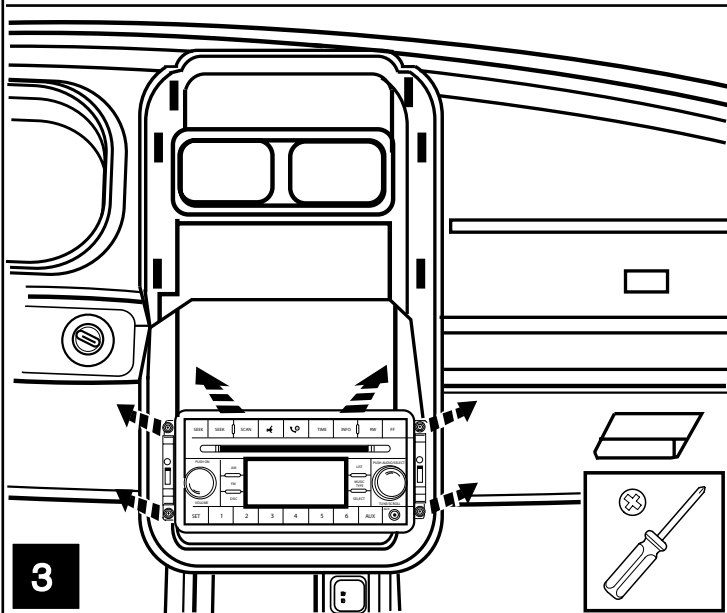
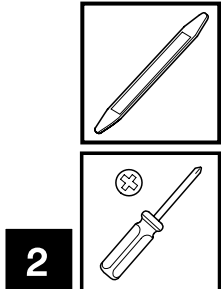
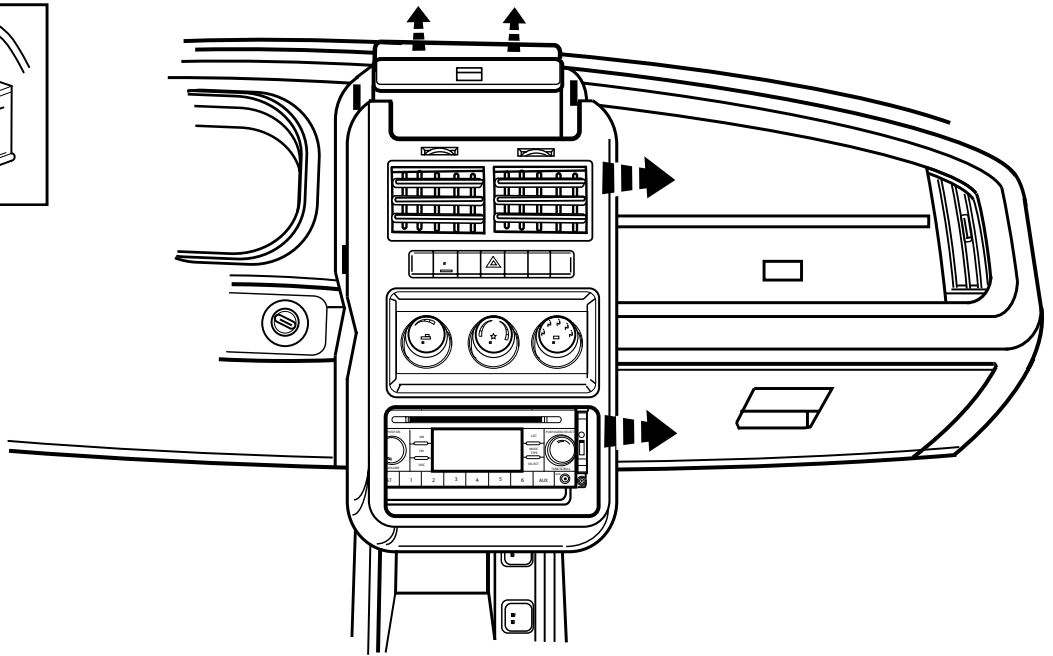
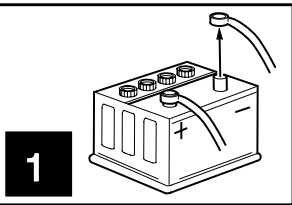

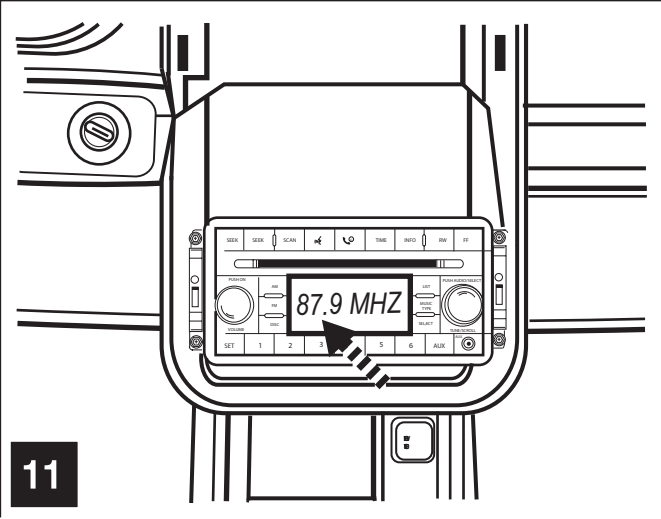
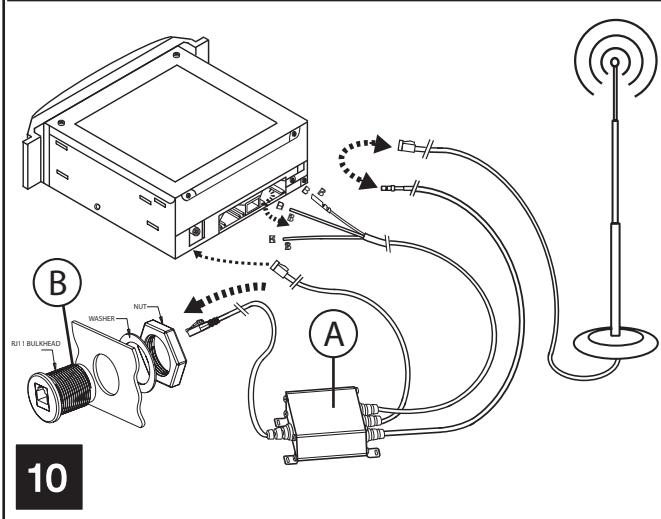
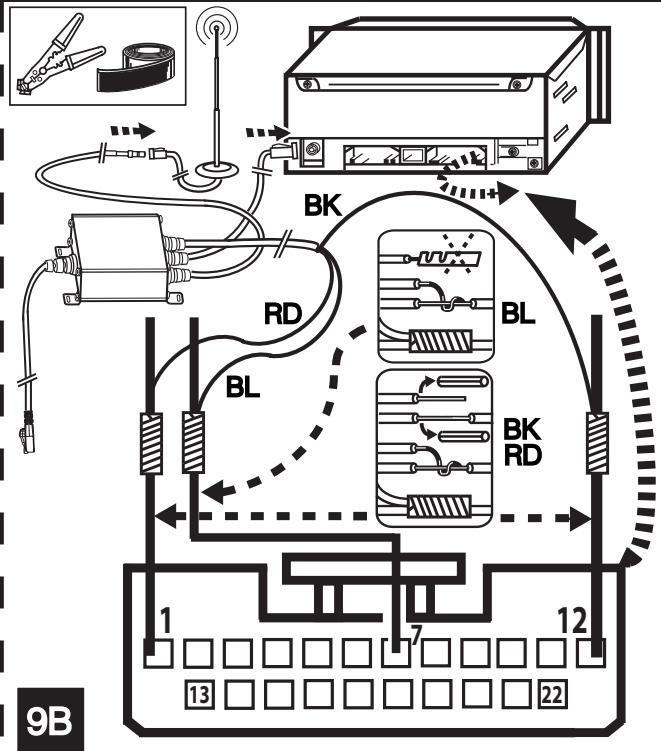
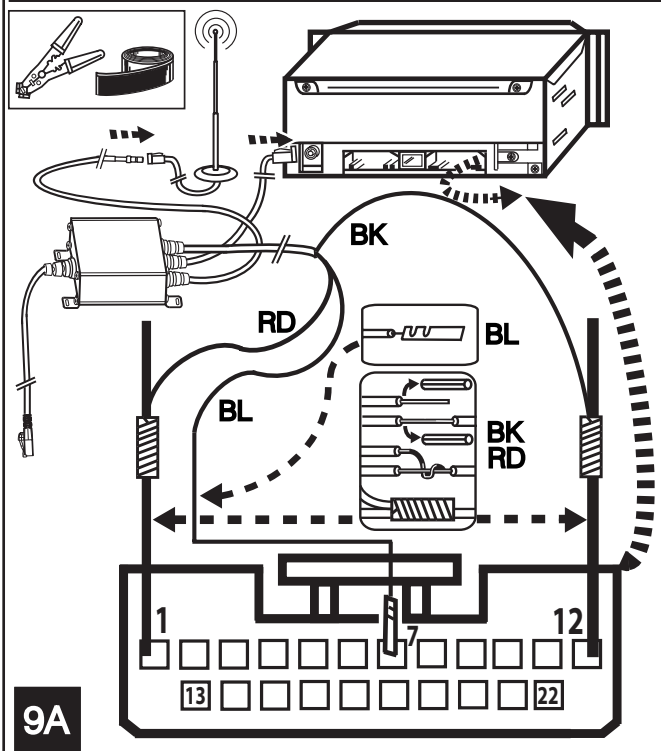
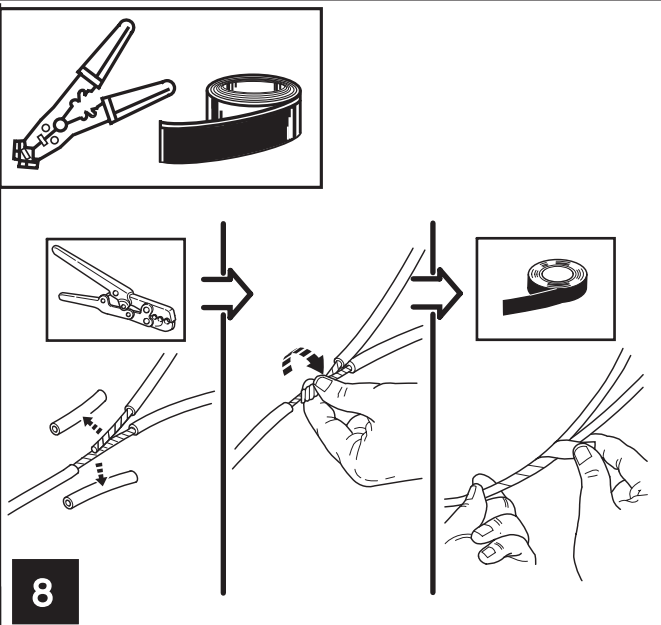
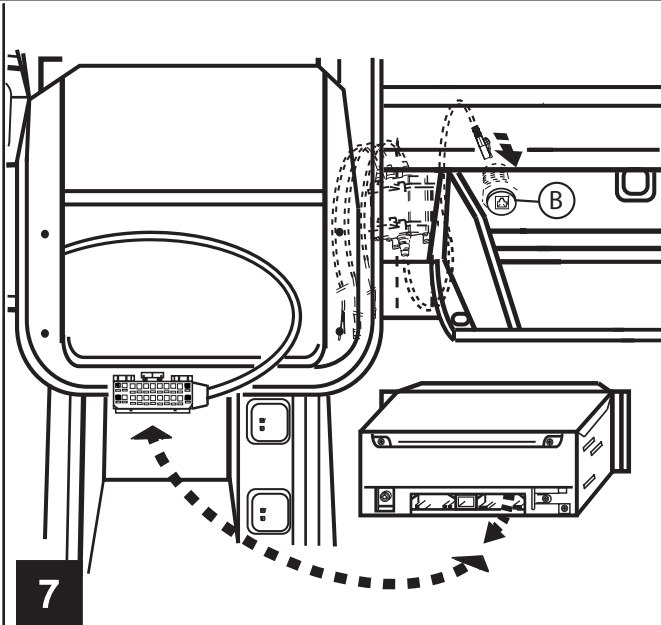

RAM

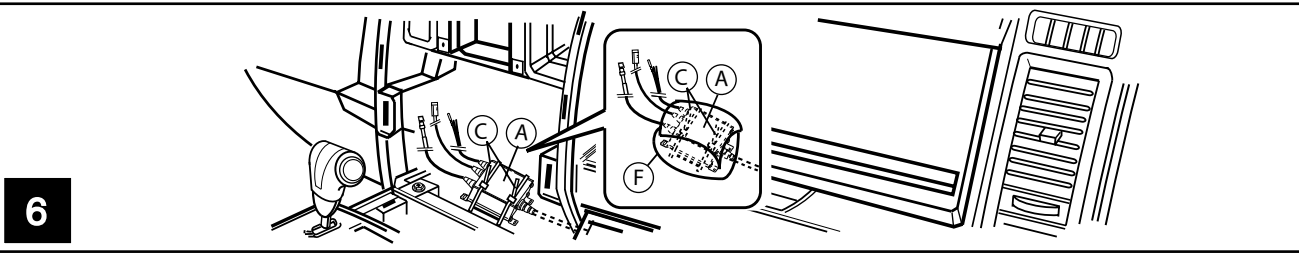
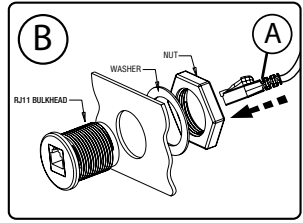
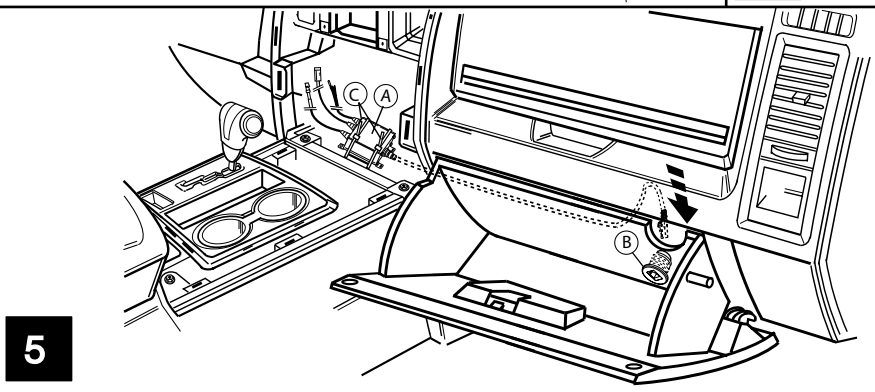
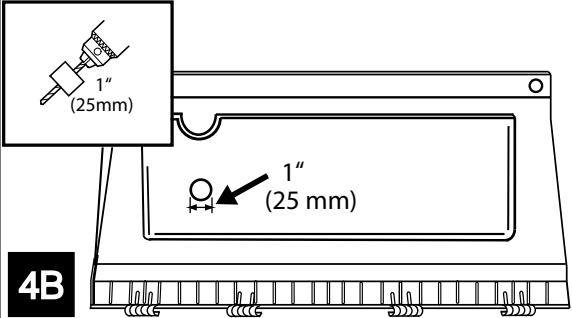
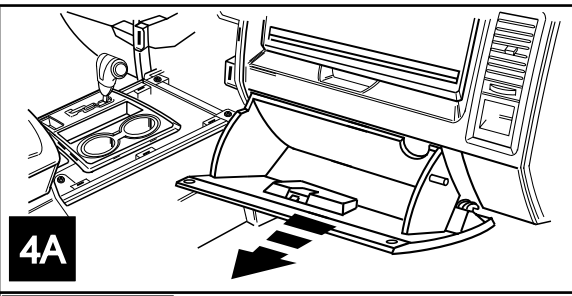
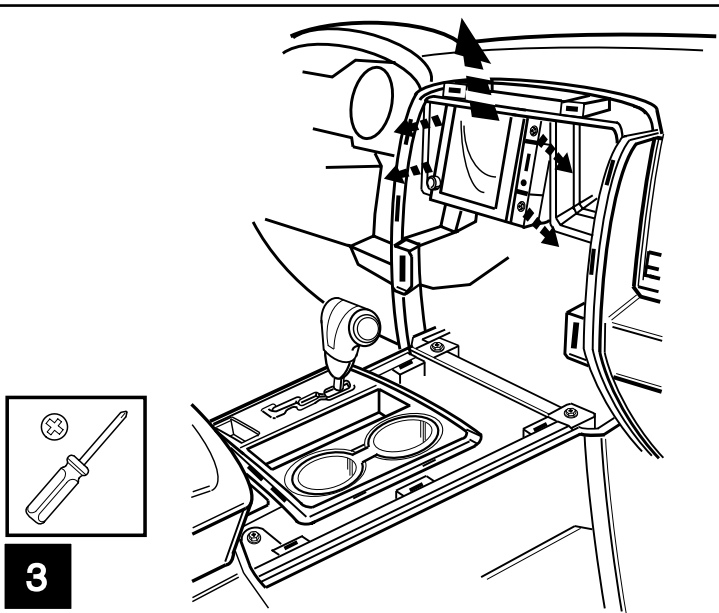
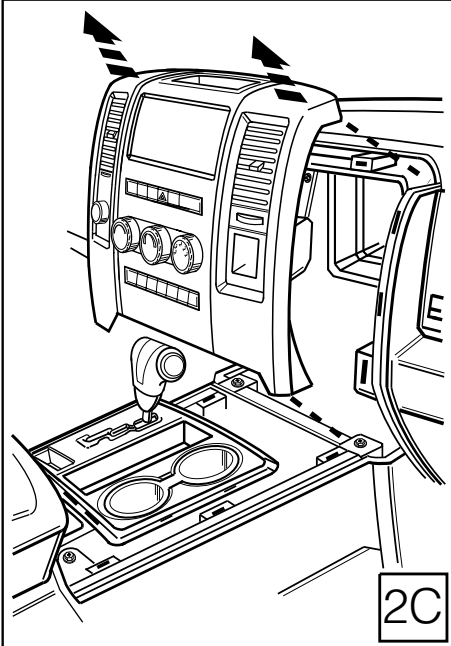
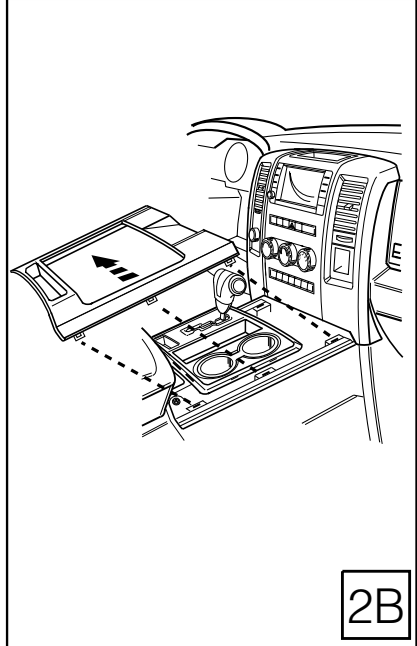
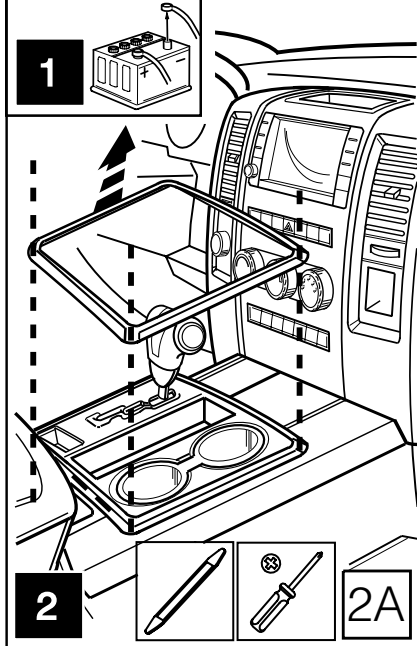

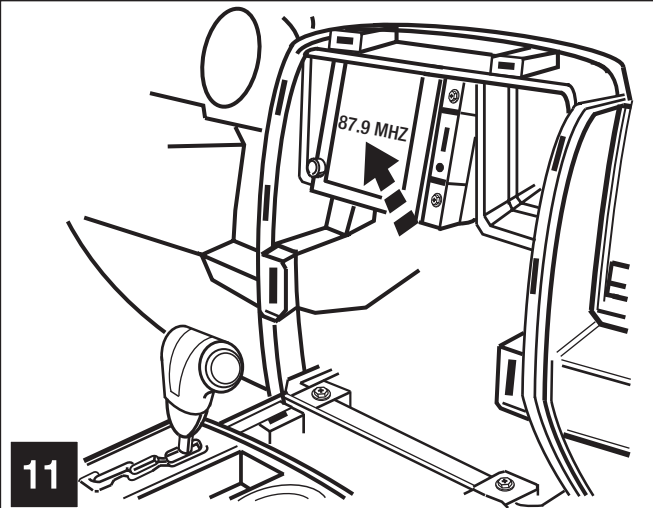
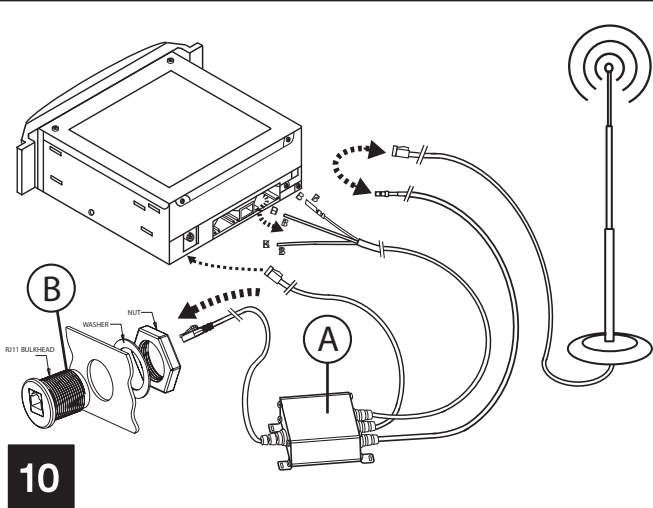
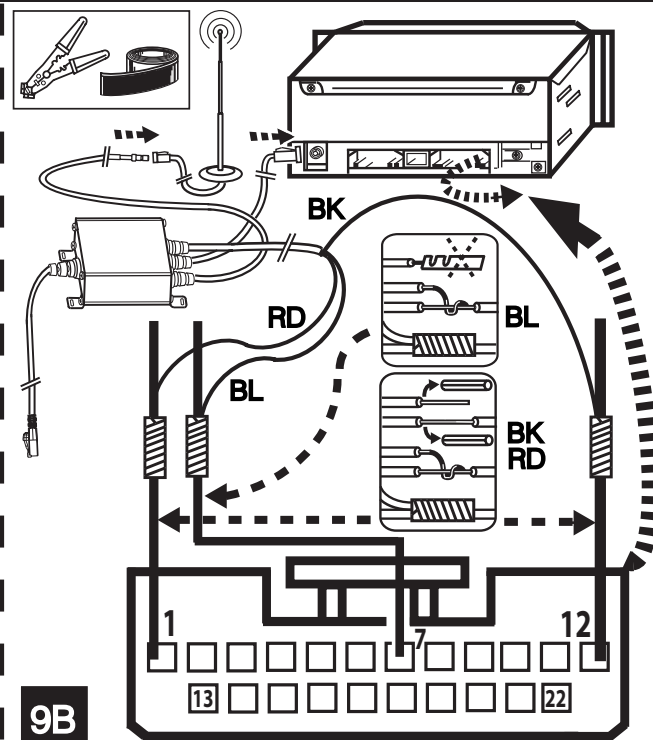
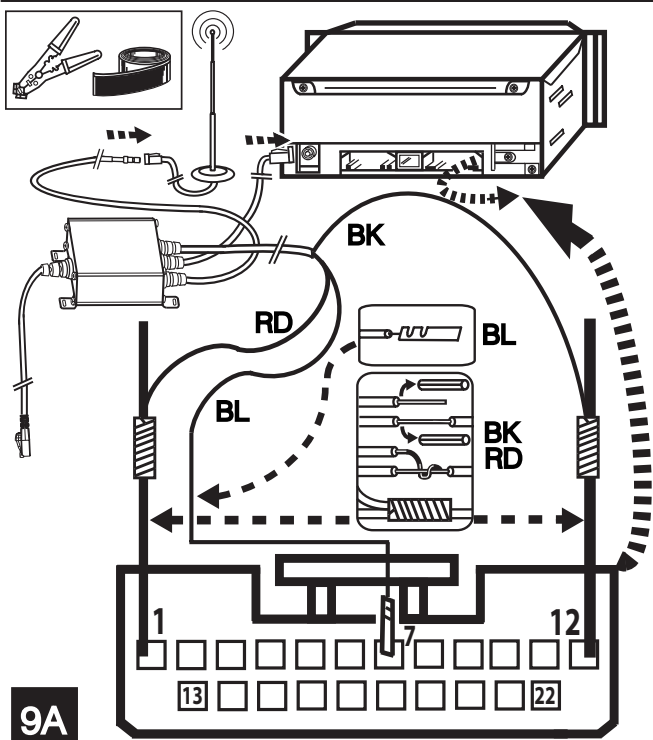
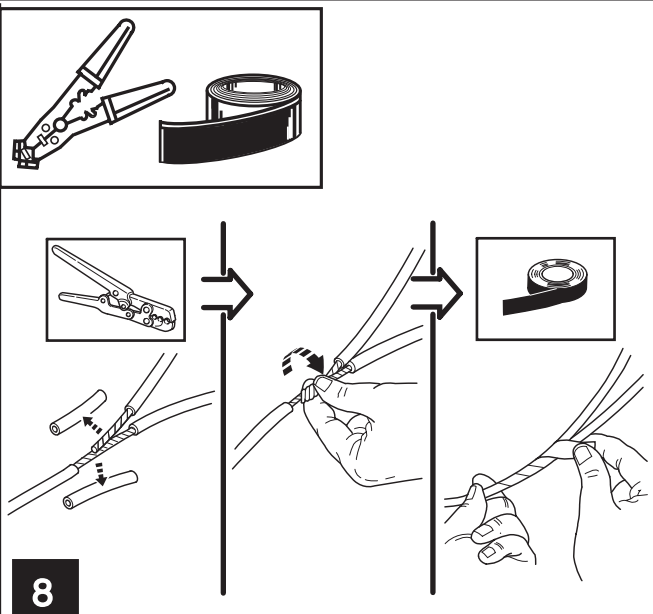
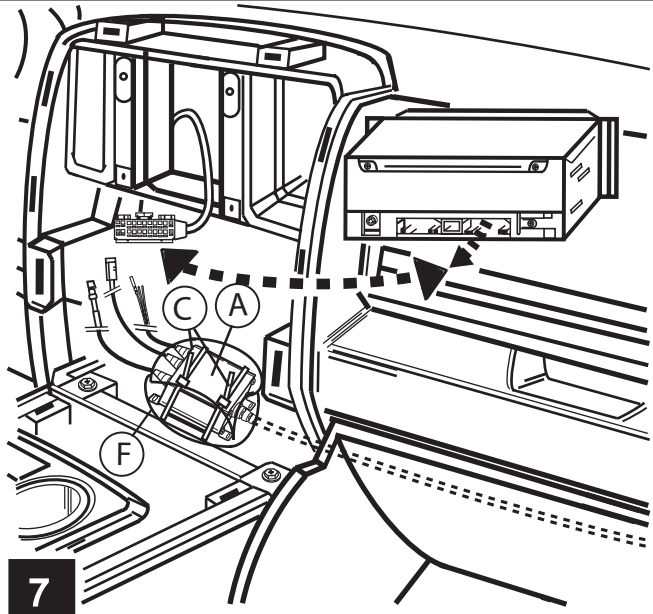

CHALLENGER

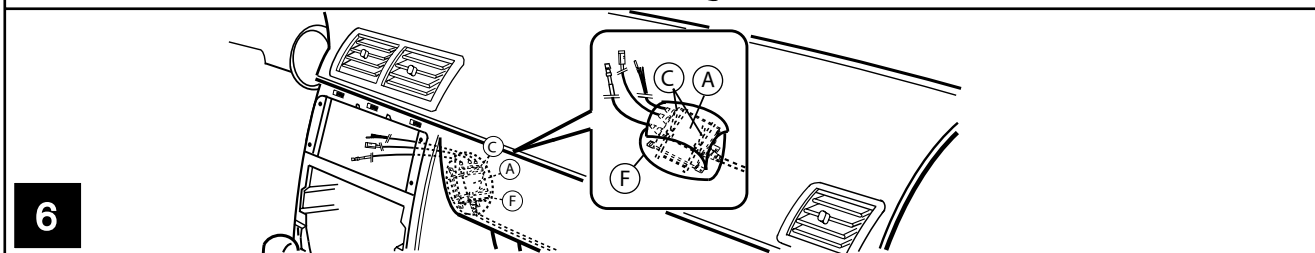
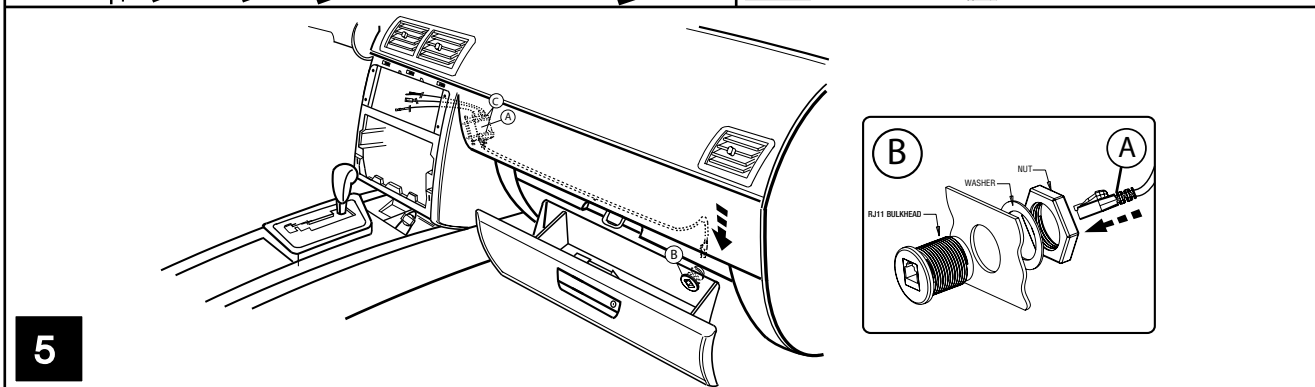
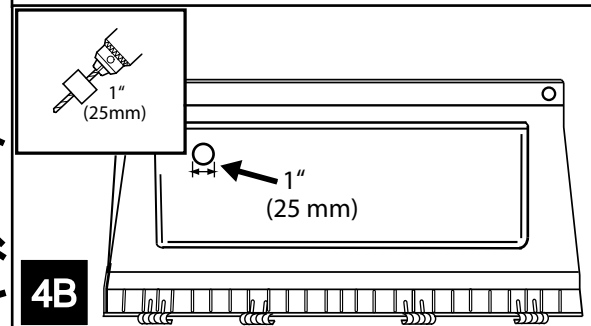
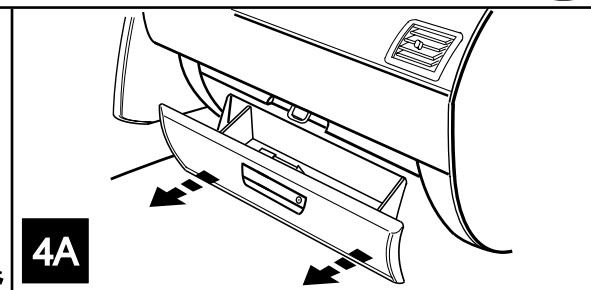
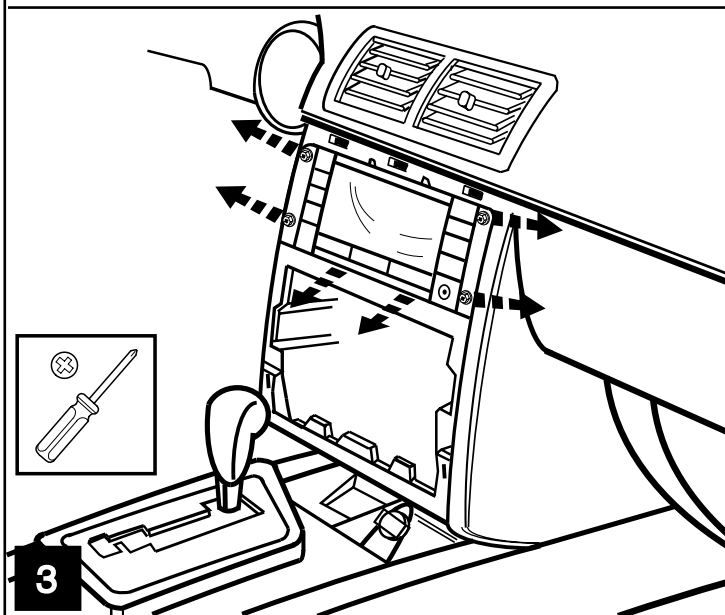
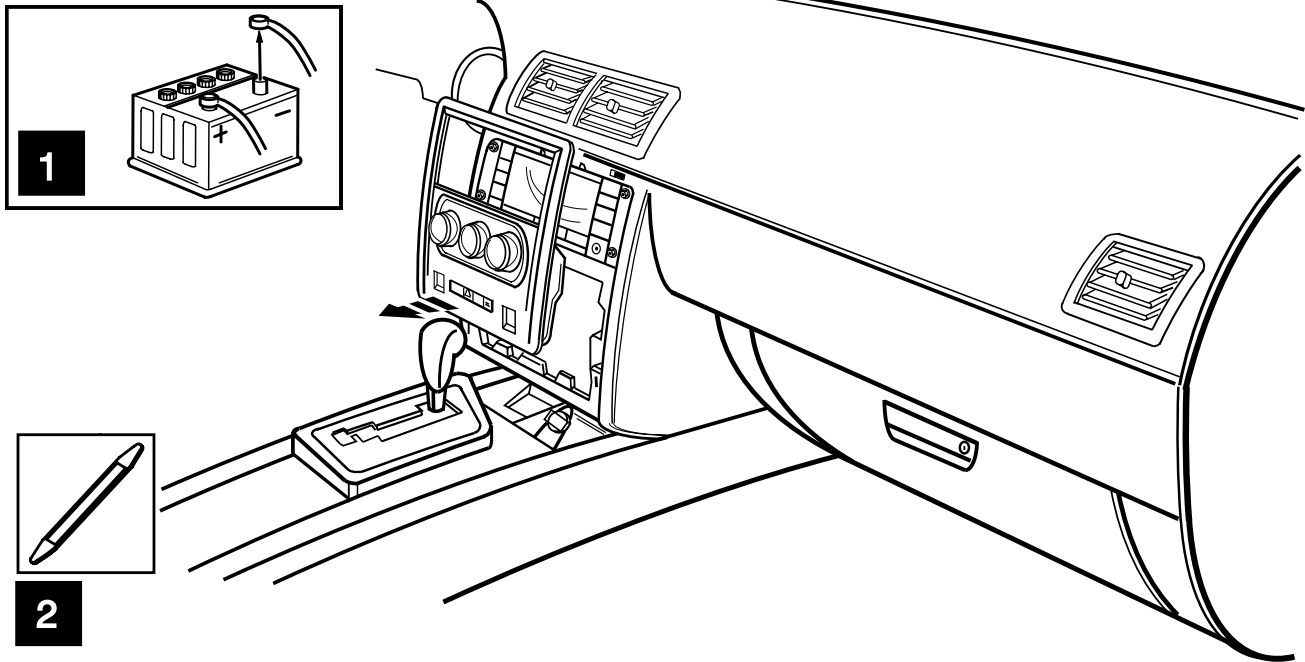

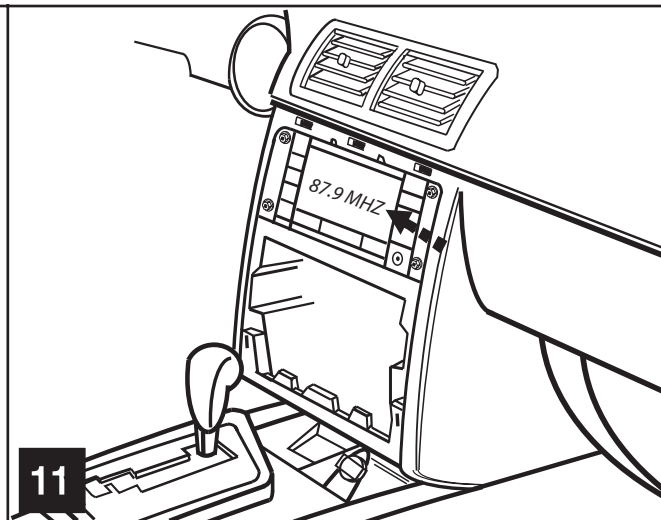
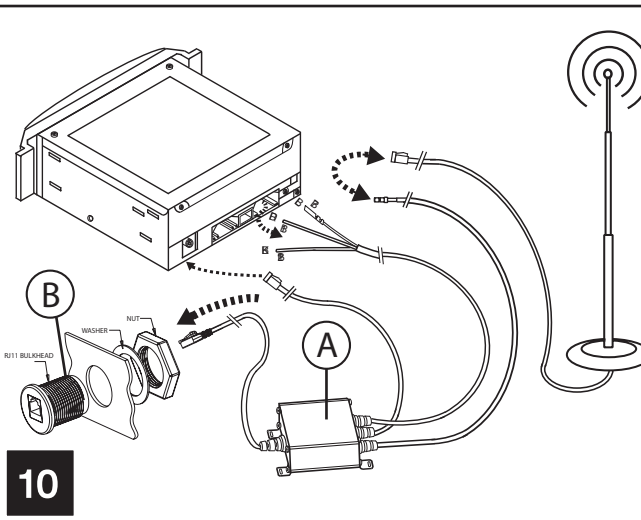
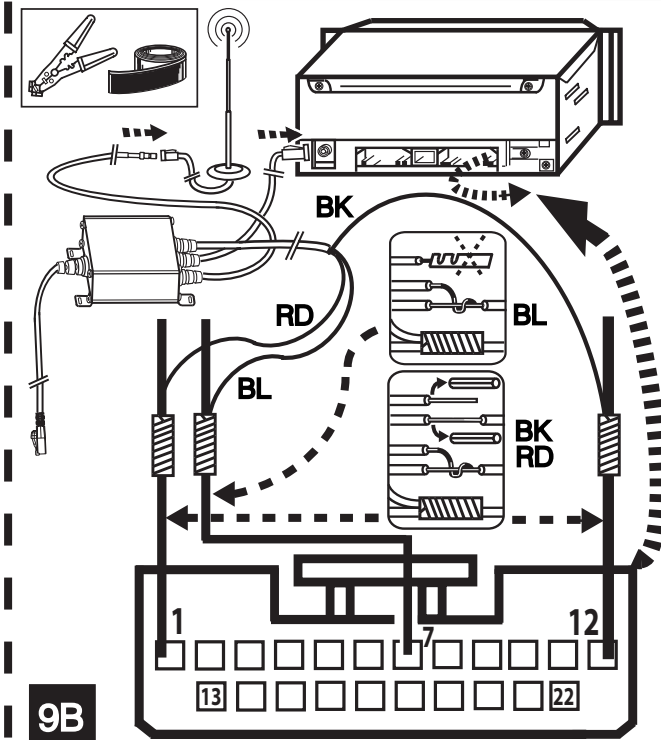
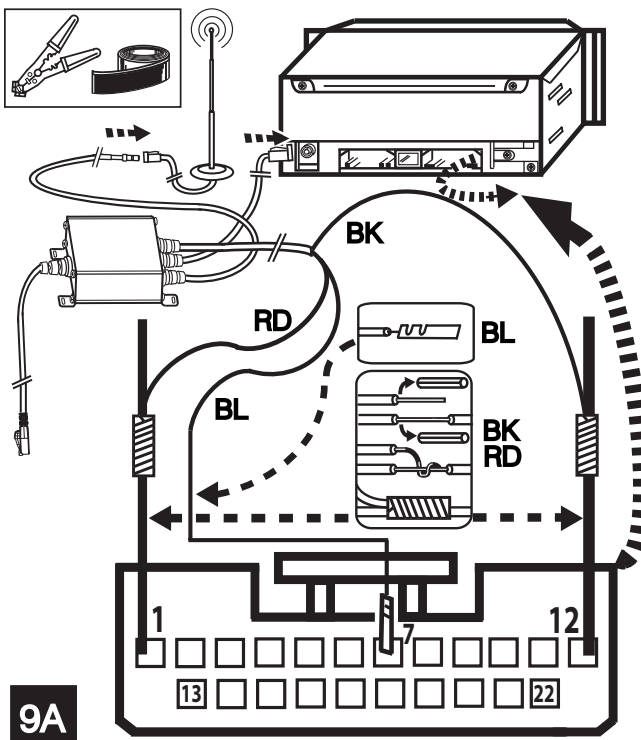
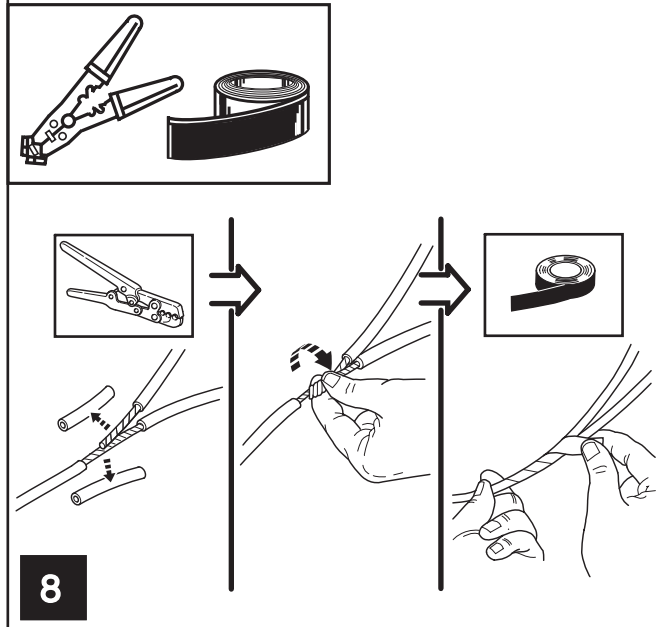
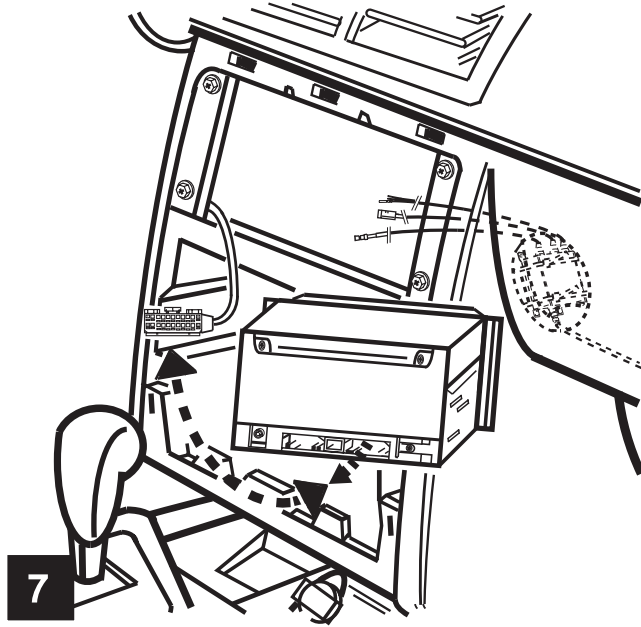

CALIBER

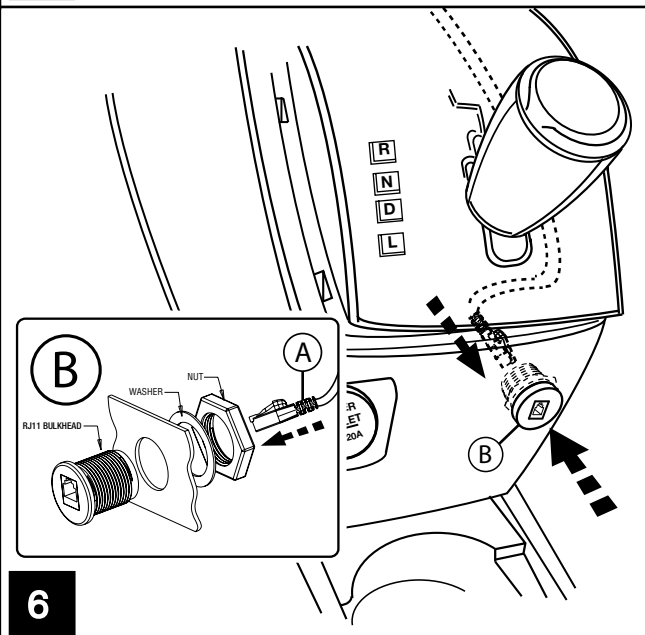
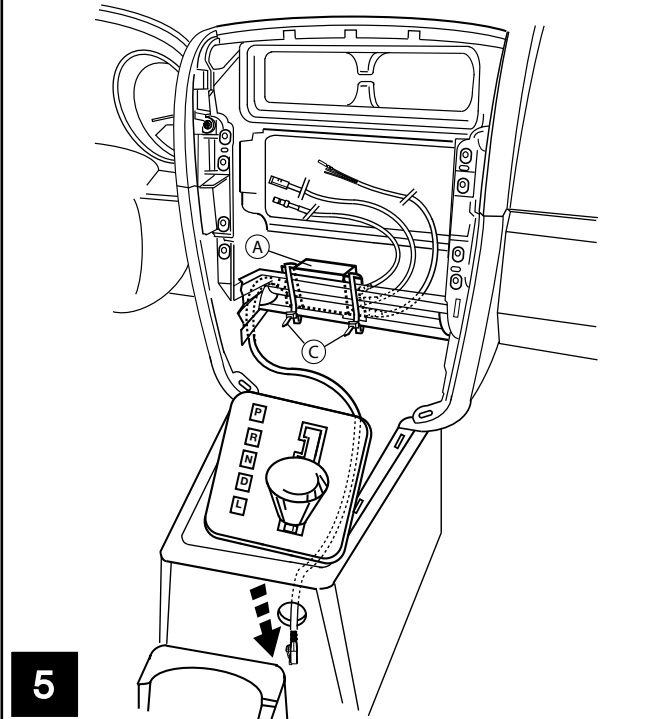
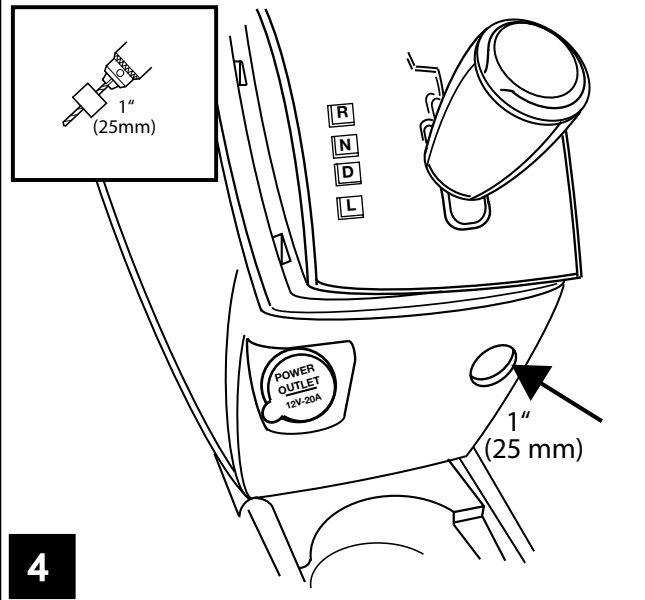
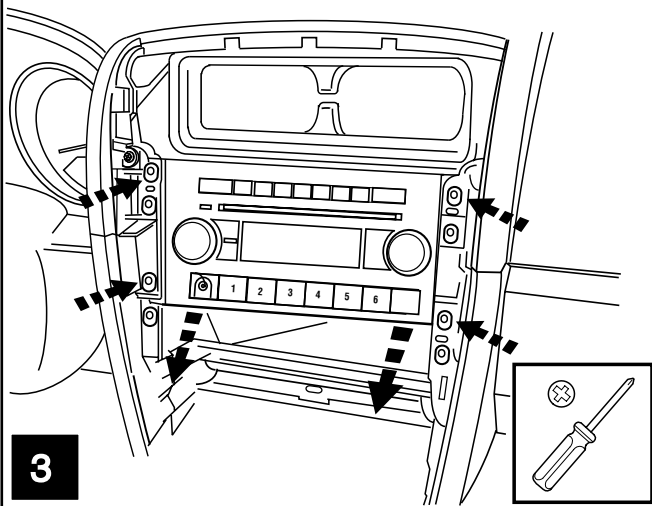
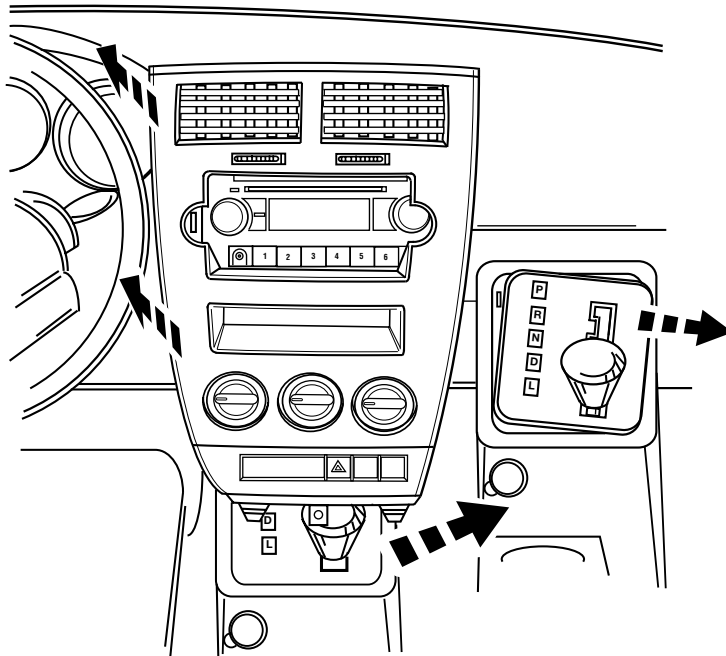
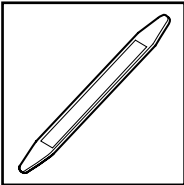
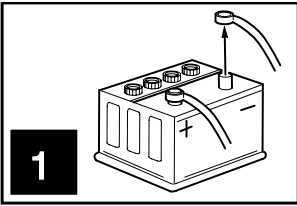

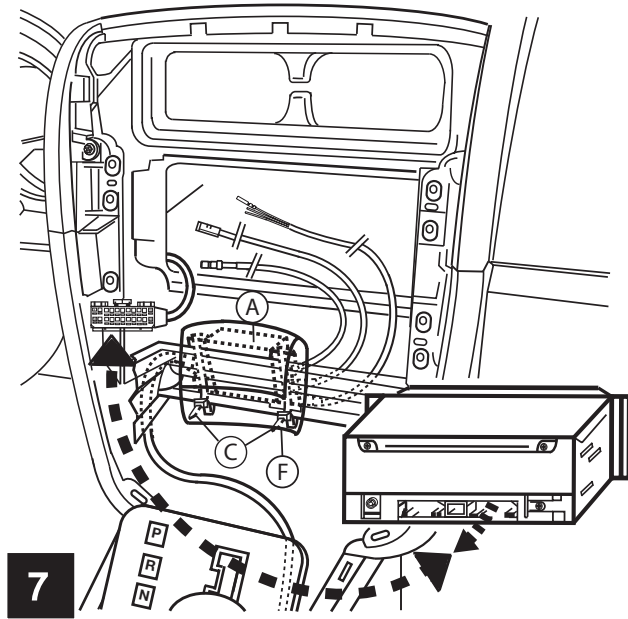

7

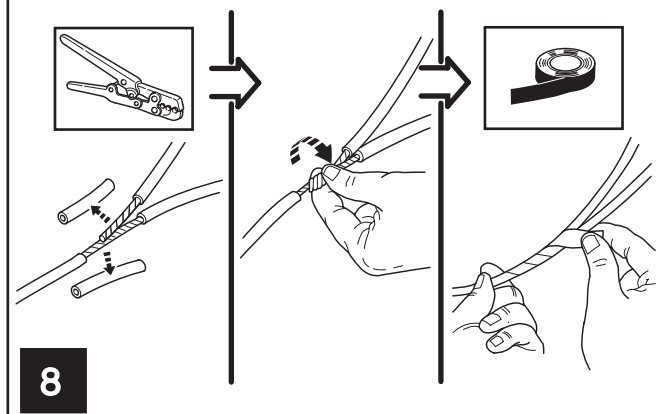
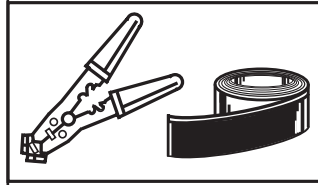

8

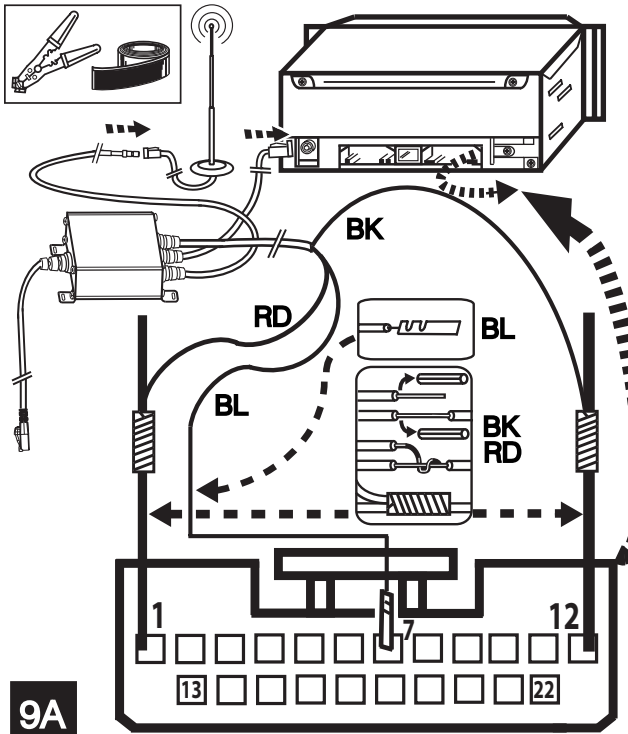

9A

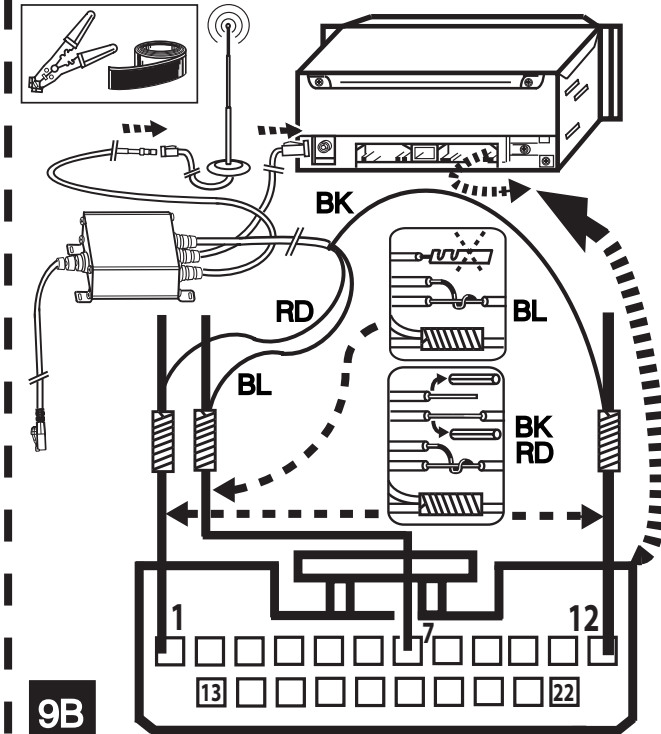

9B

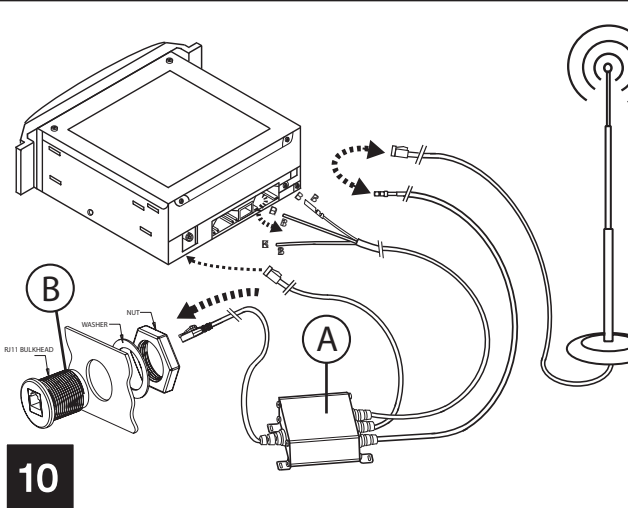

10

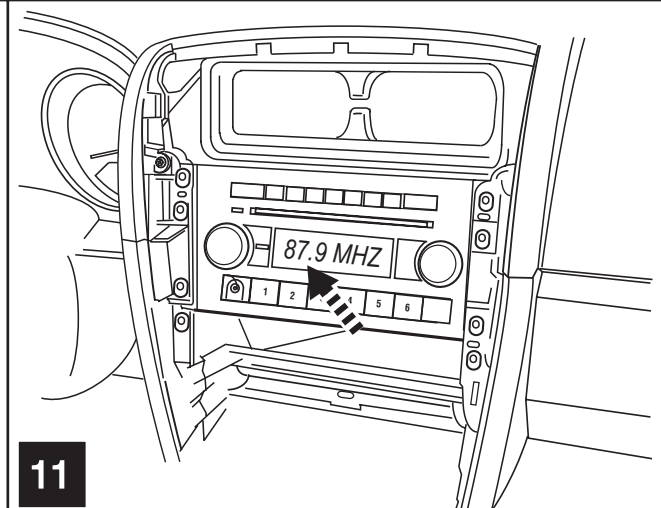

11

COMMANDER XH

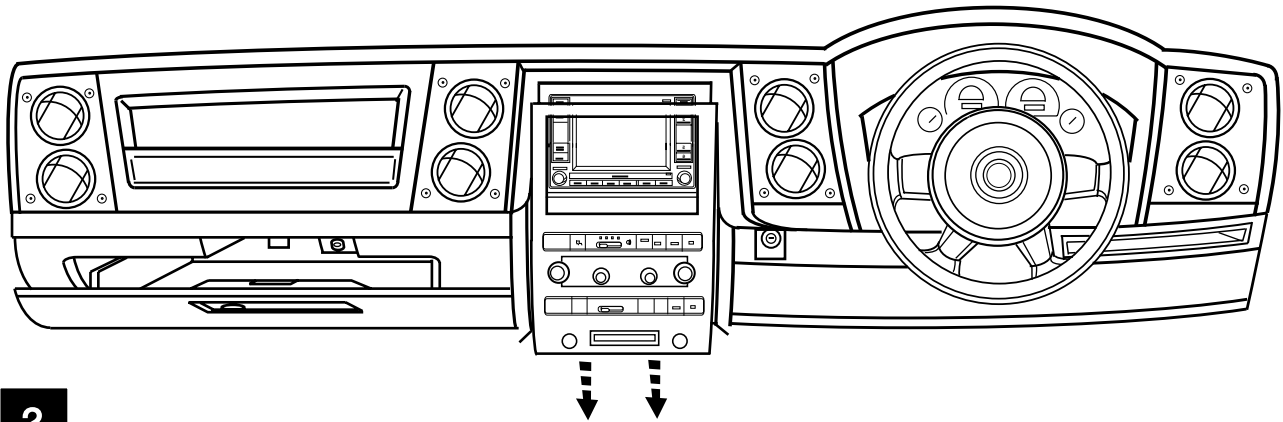
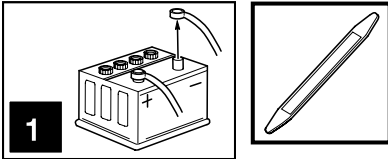

COMMANDER XK

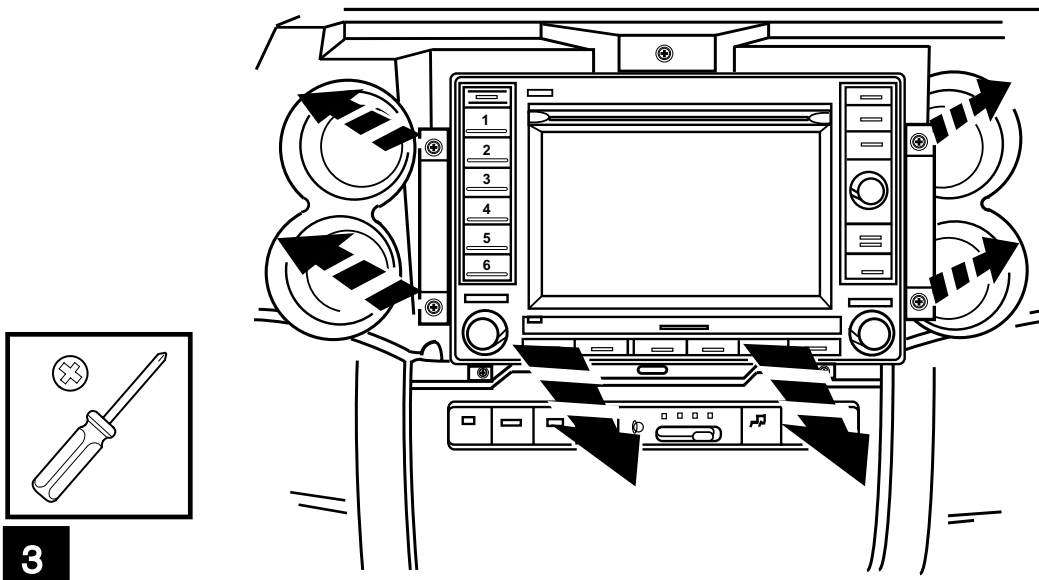
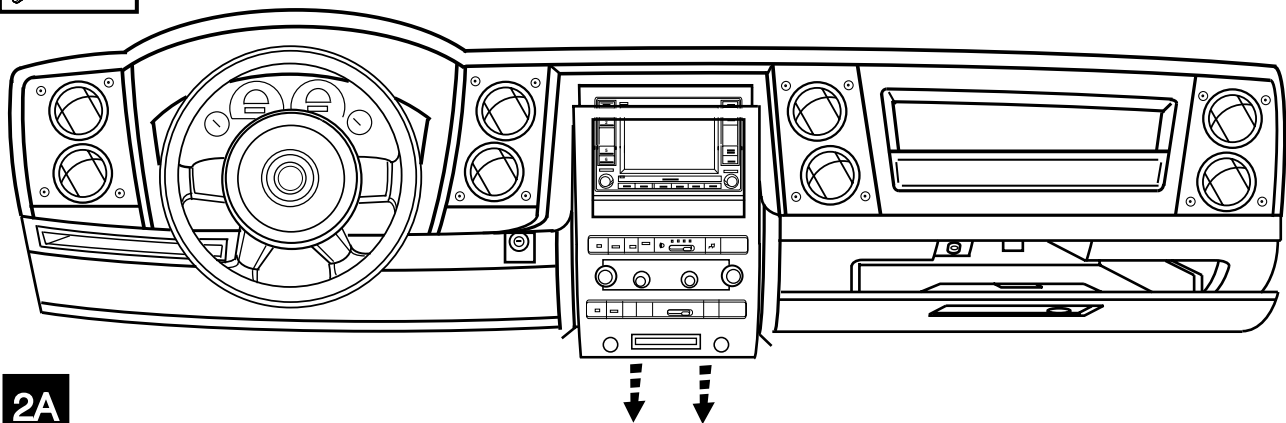
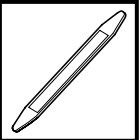

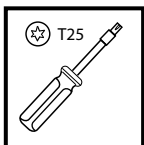
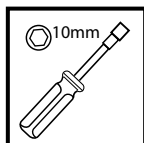
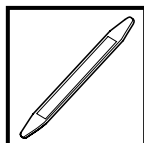
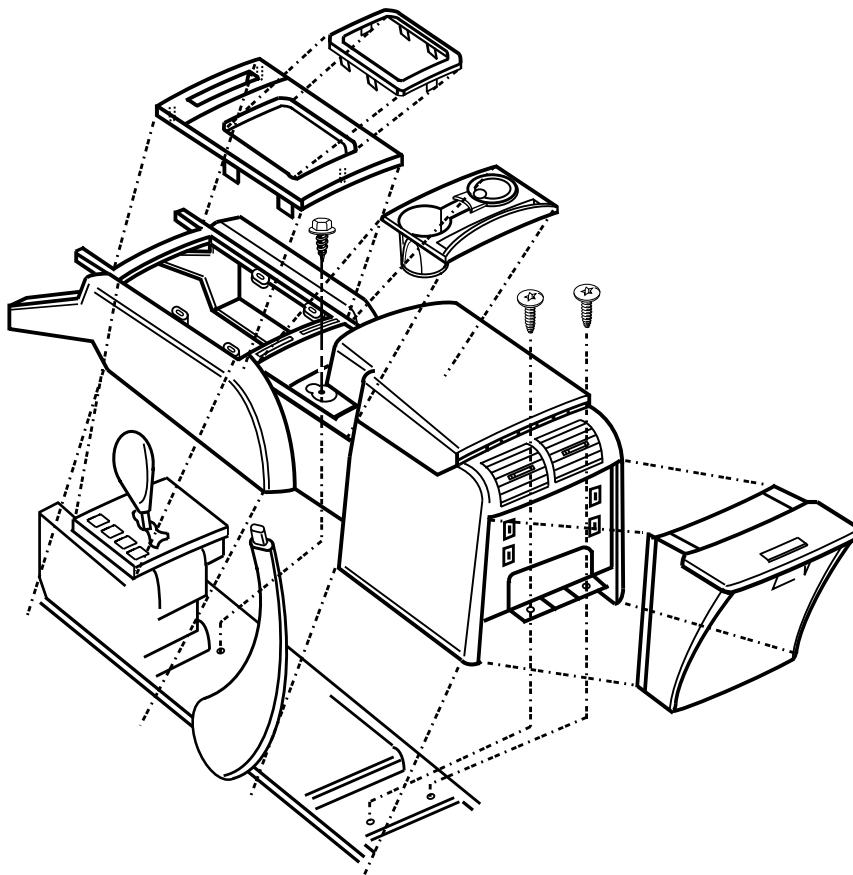

4

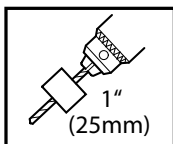
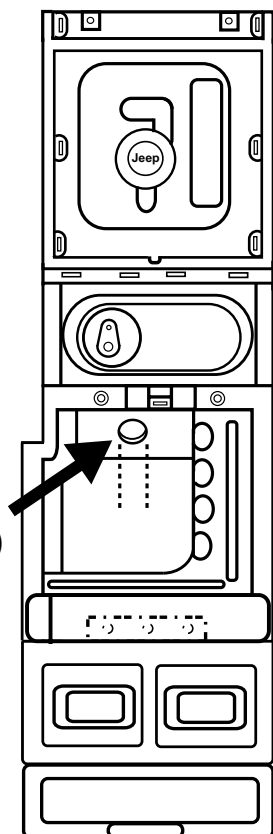

5

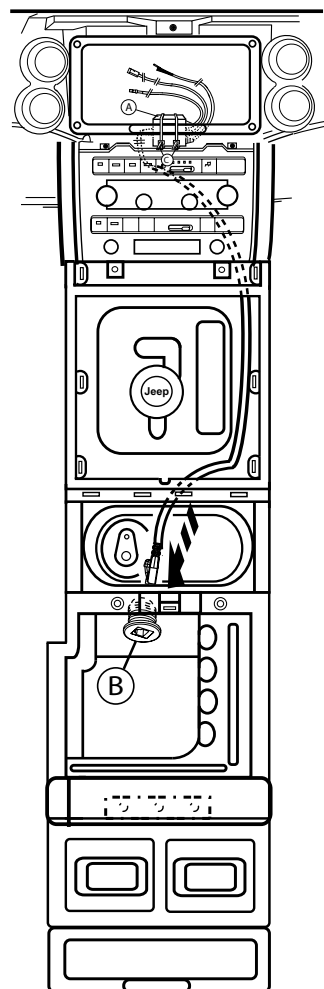

6

COMMANDER XH/XK

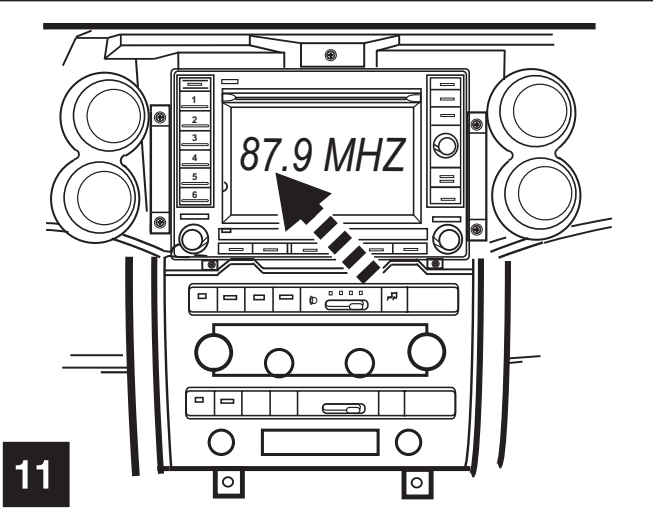
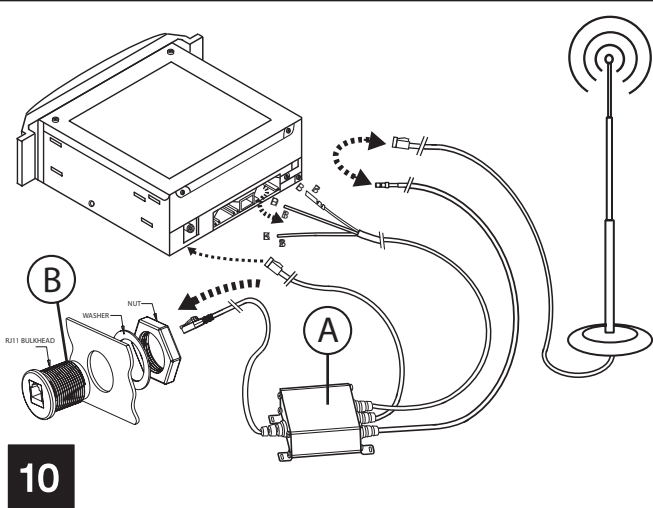
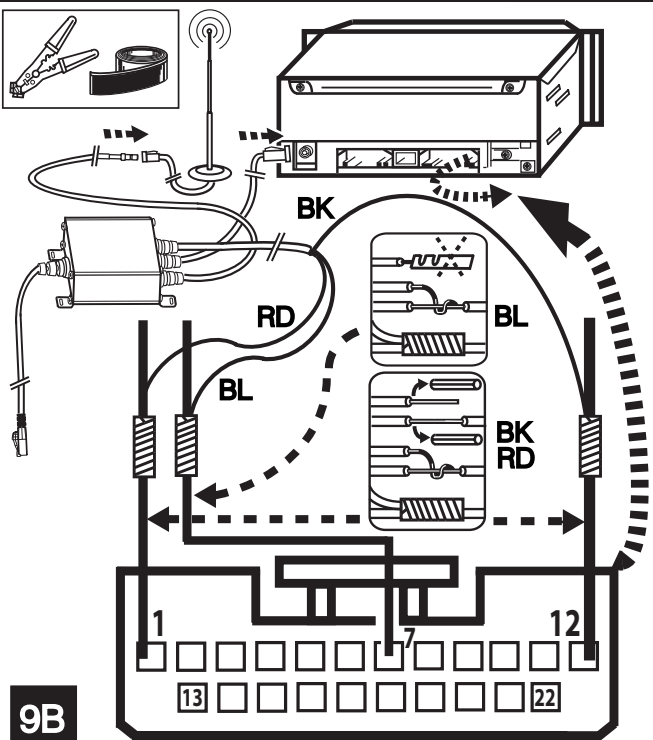
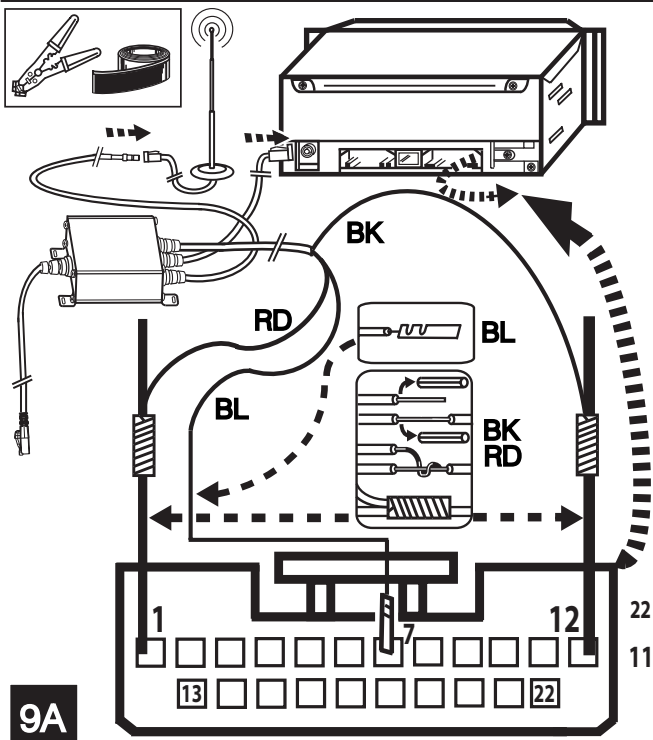
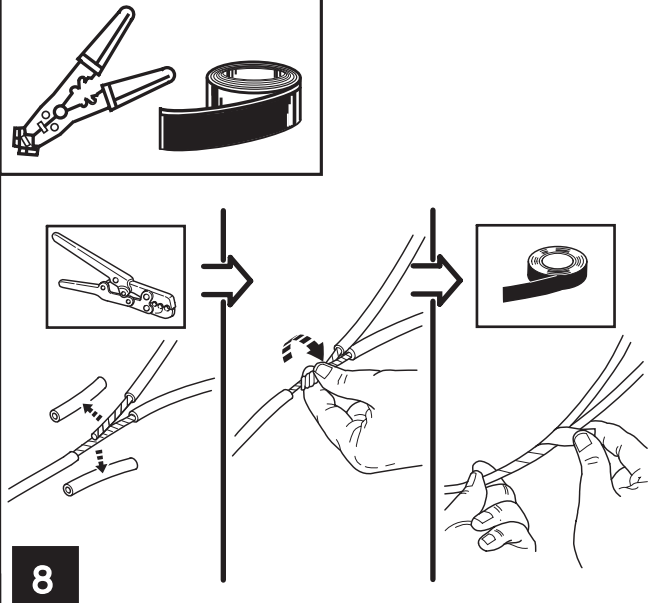
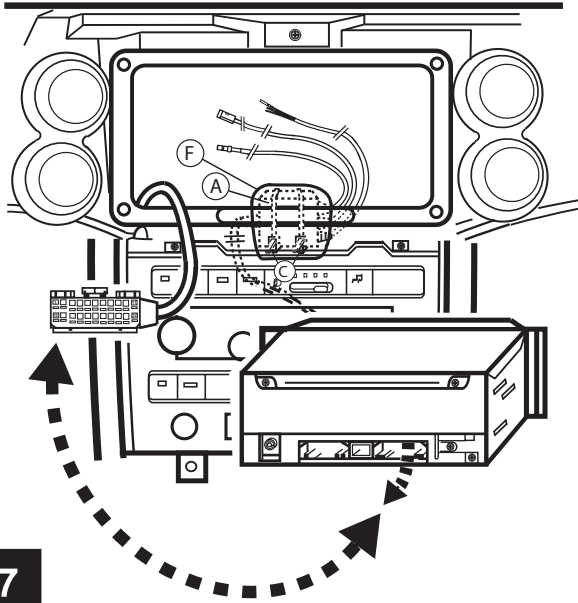

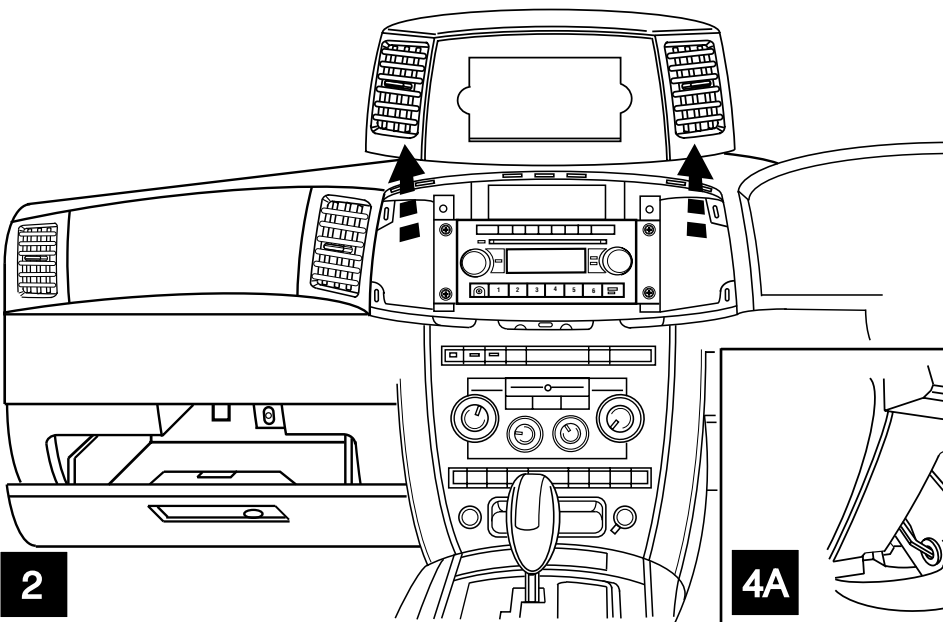

2

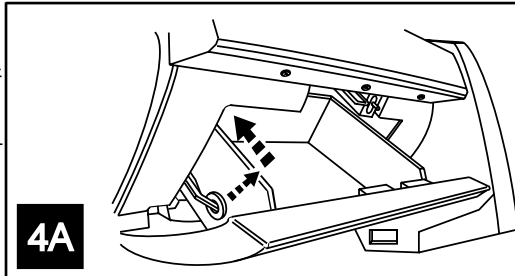
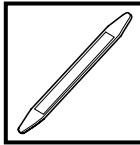
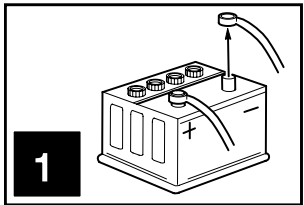

4A

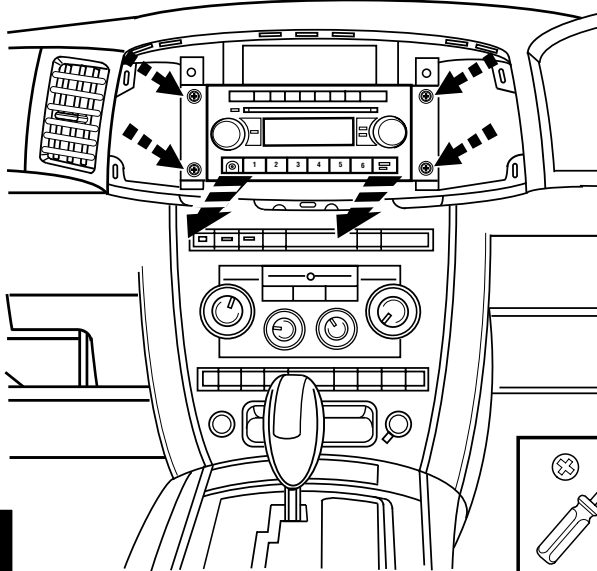

3

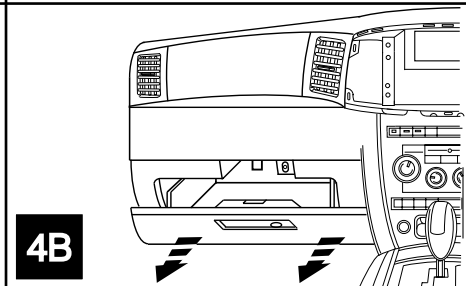

4B

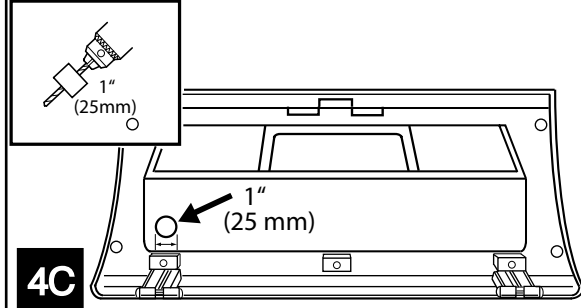

4C

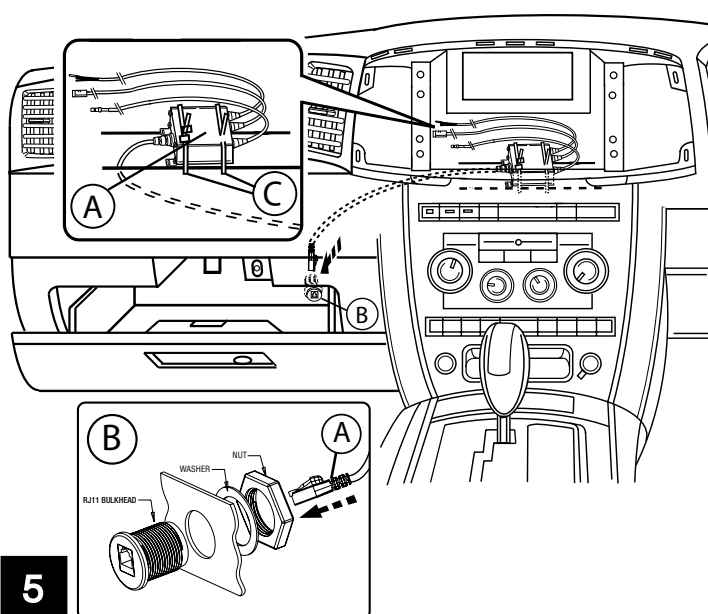

5

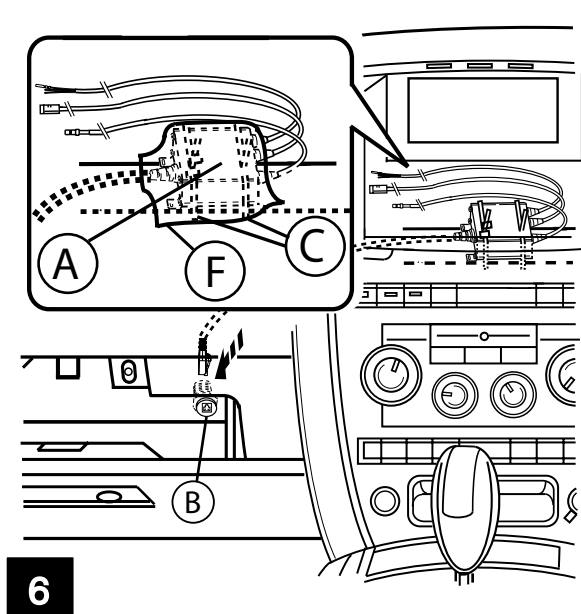

6

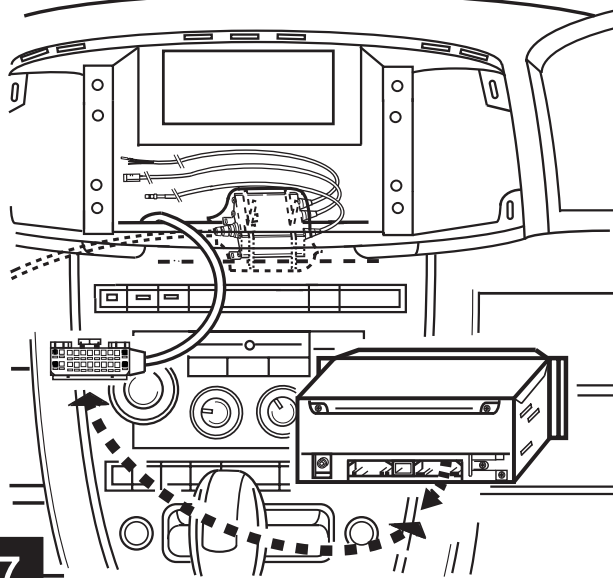

7

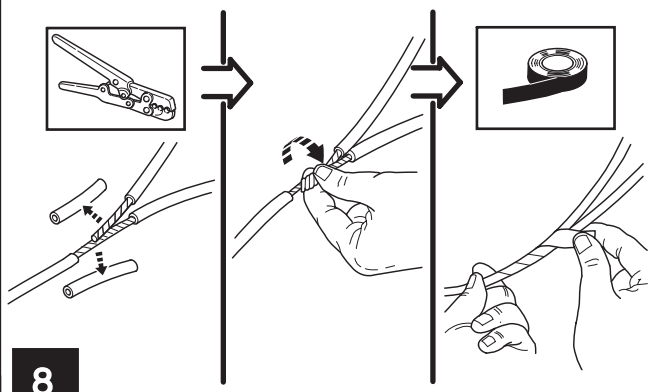
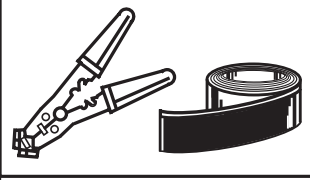

8

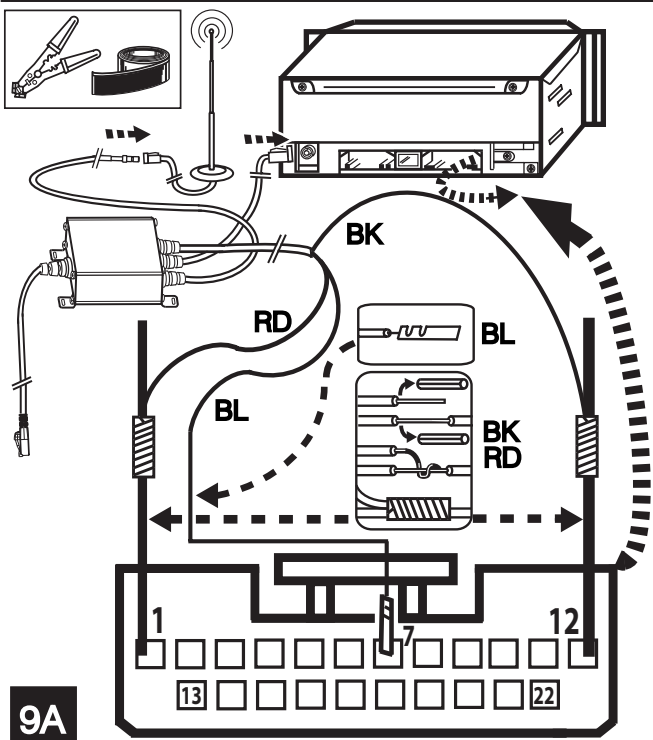

9A

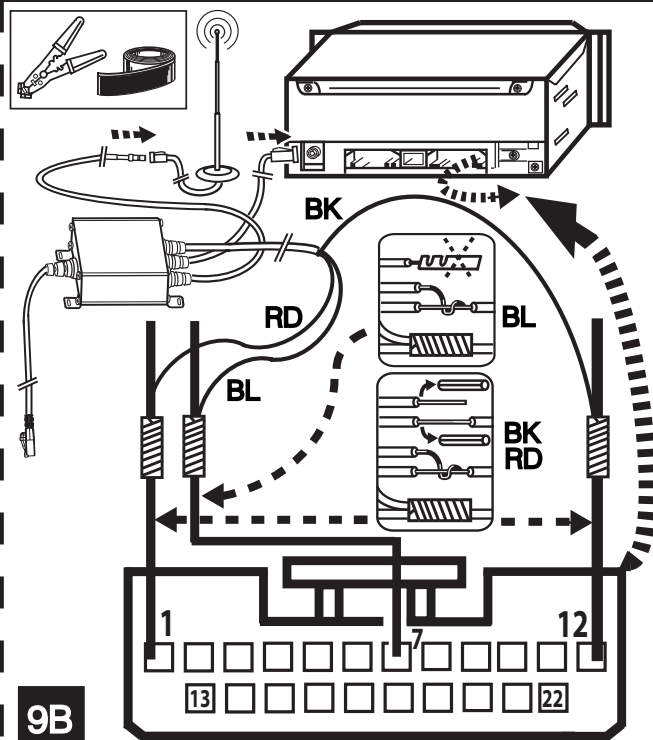

9B

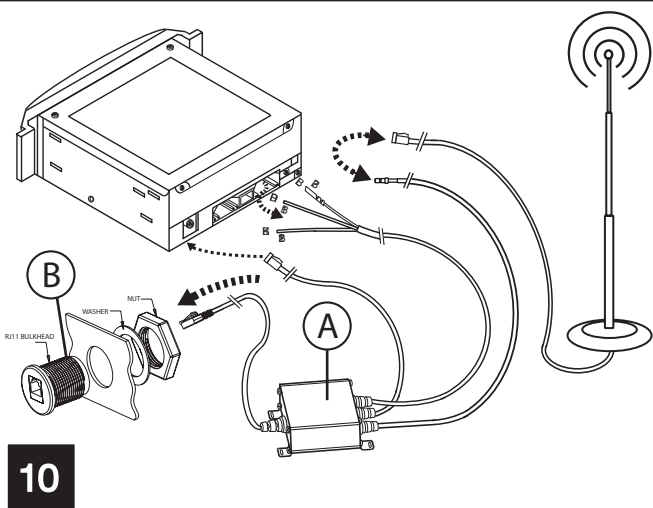

10

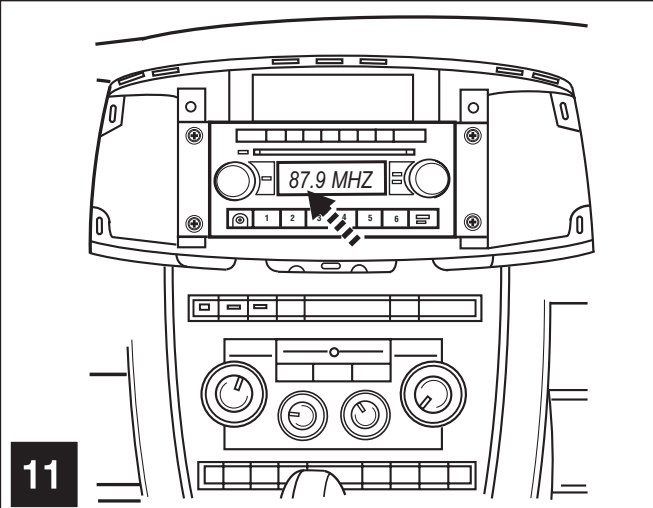

11

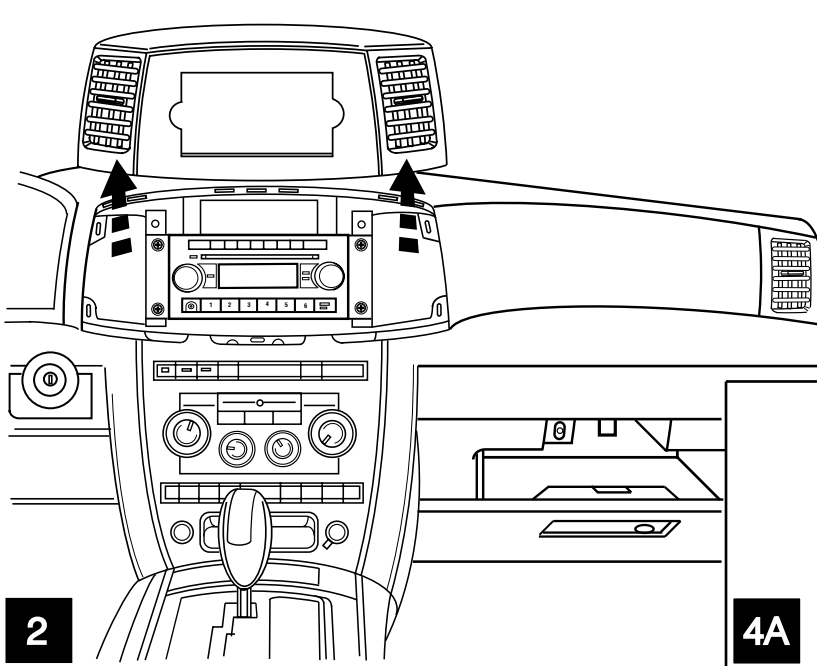

2

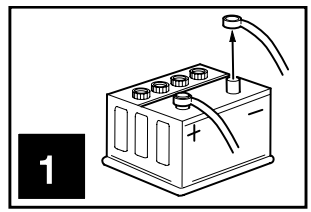

1

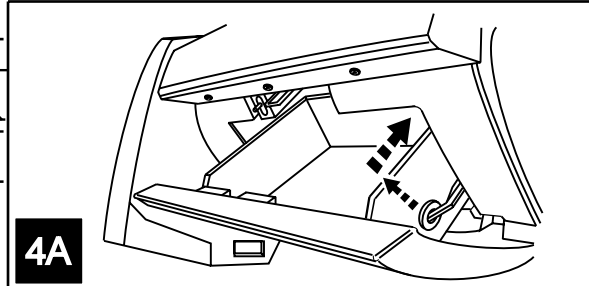

4A

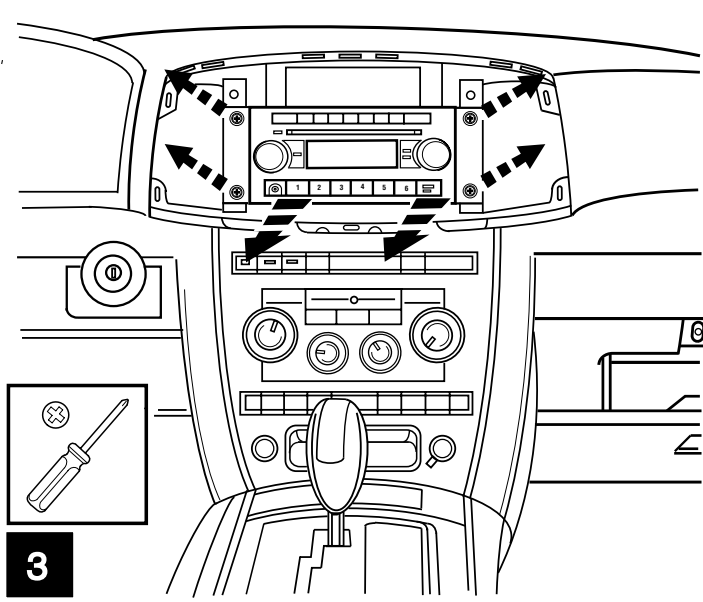

3

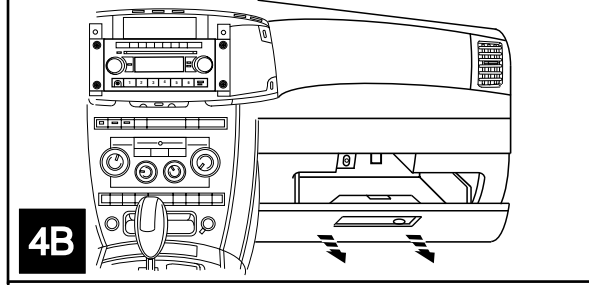
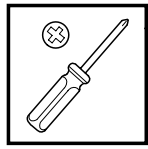

4B

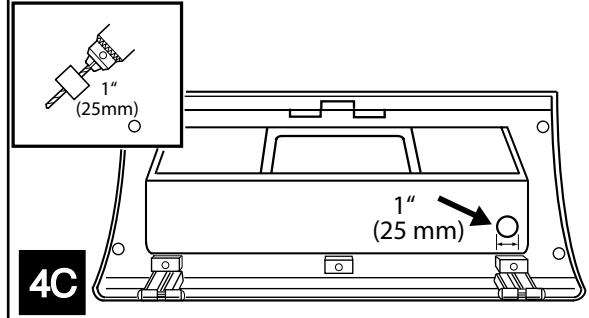

4C

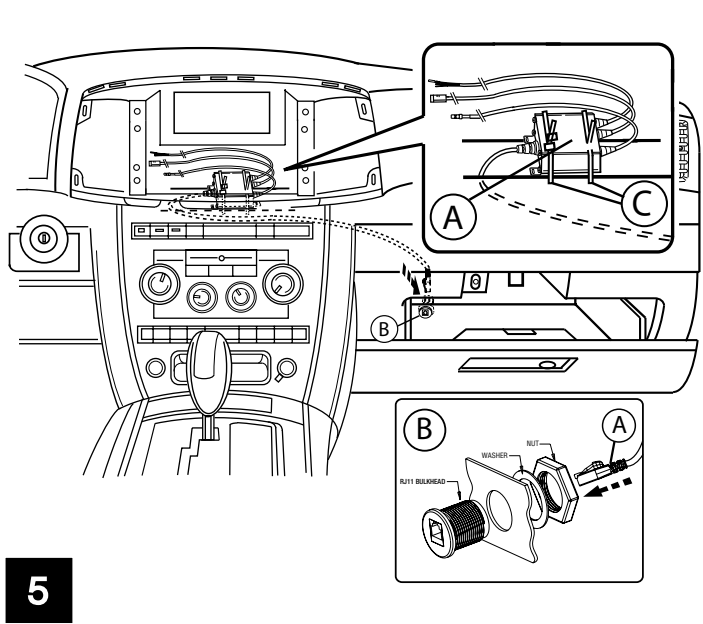

5

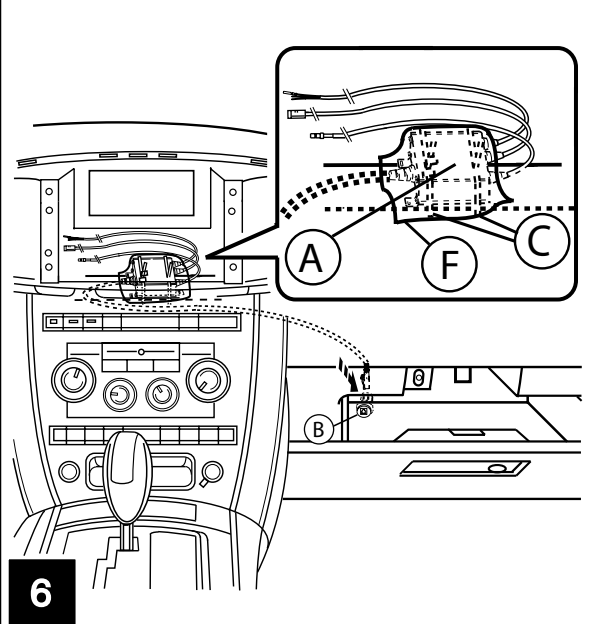
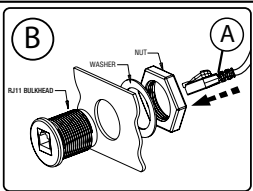

6

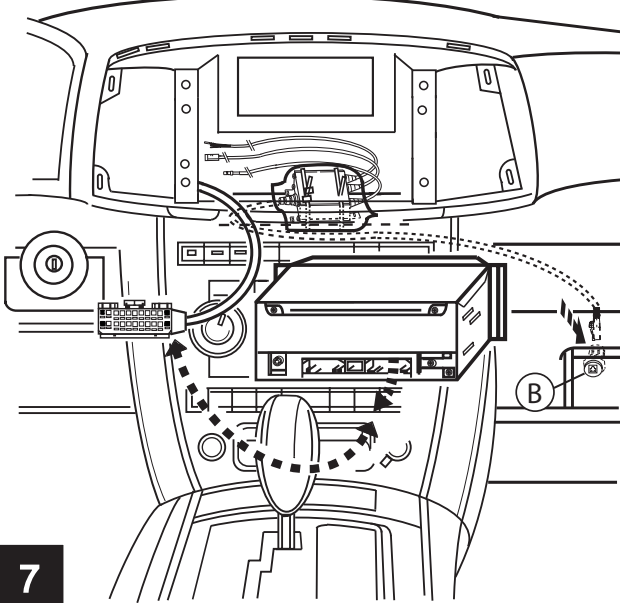

7

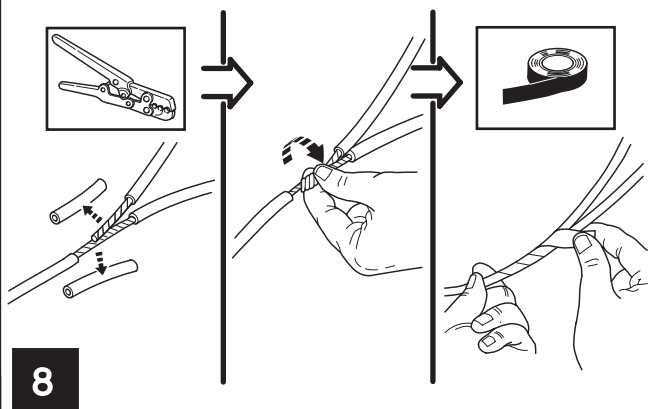
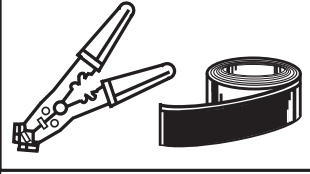

8

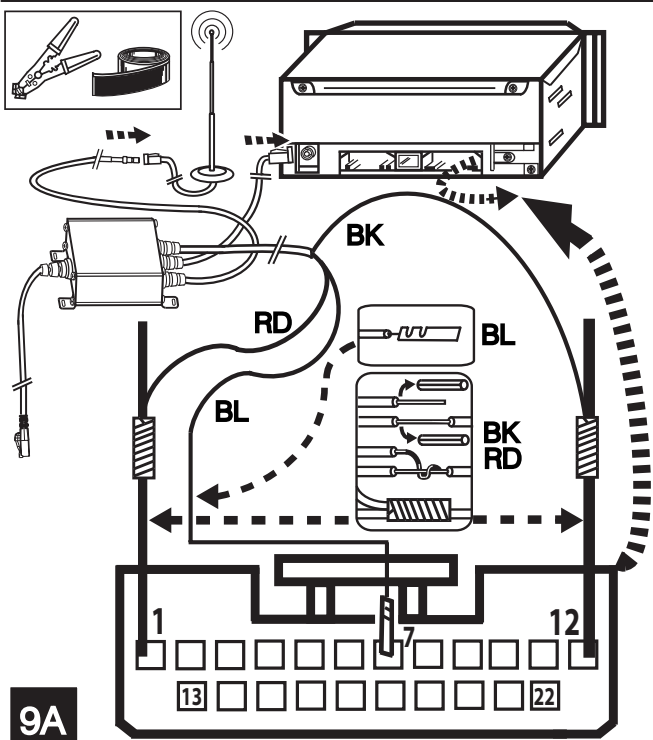

9A

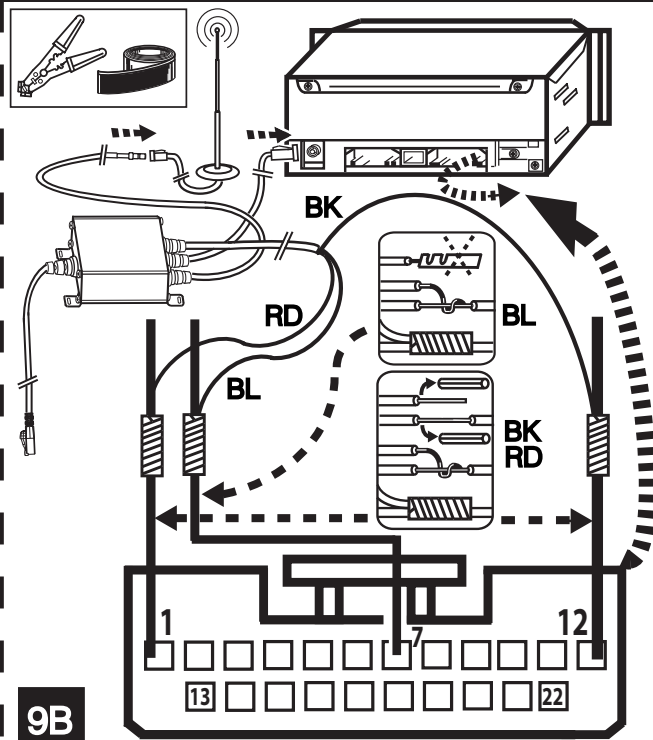

9B

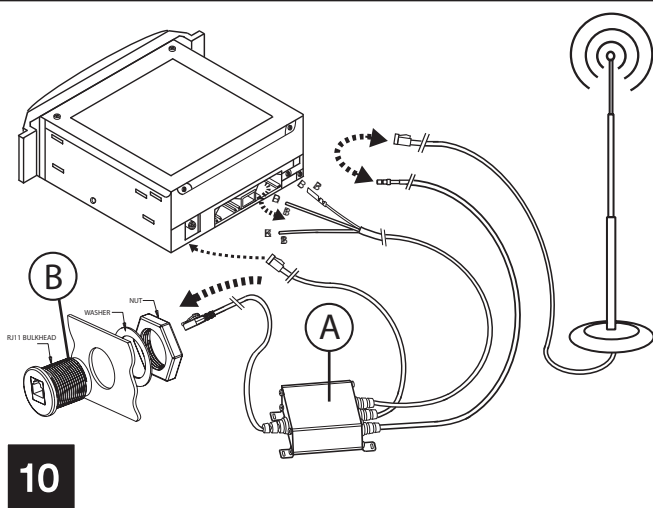

10

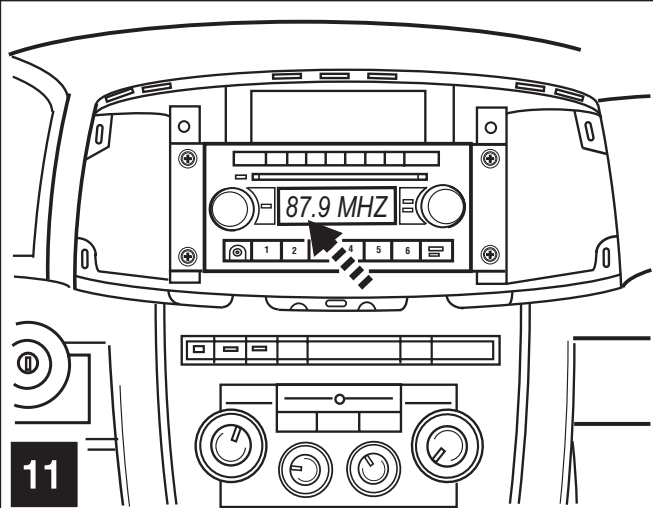

11

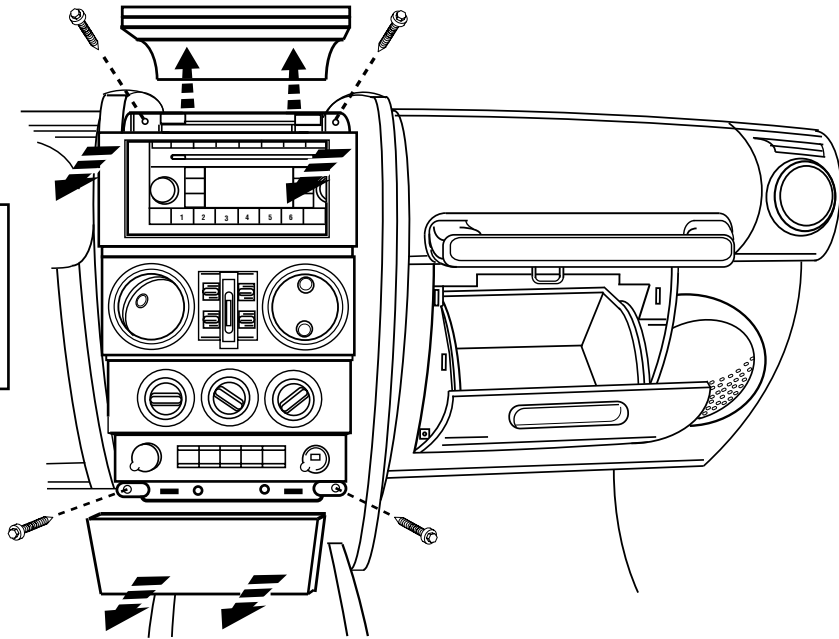
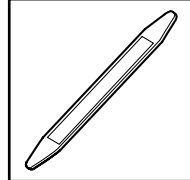
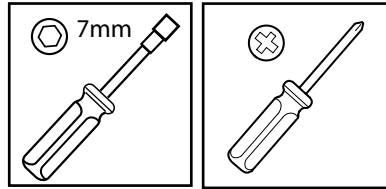
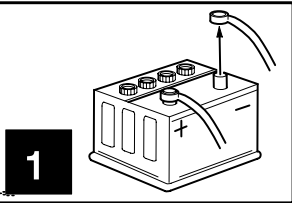

2

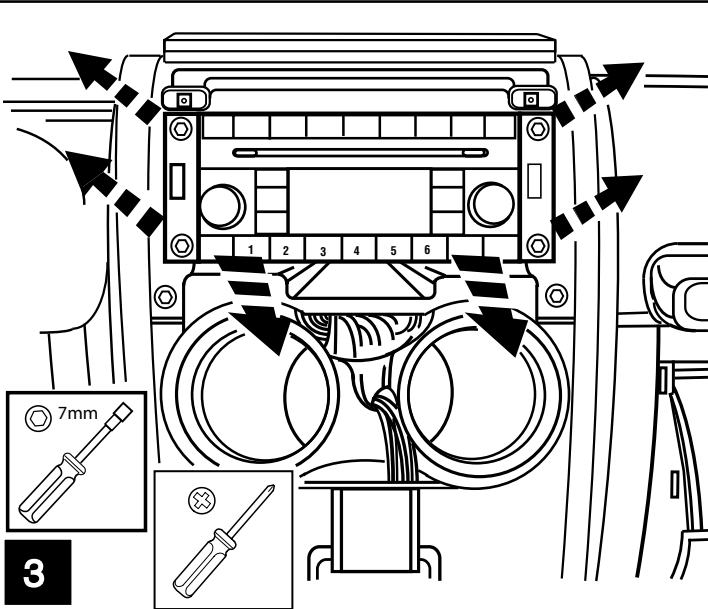

3

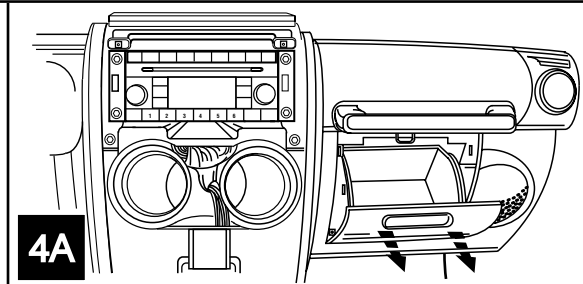

4A

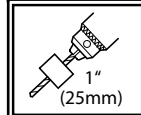

4B

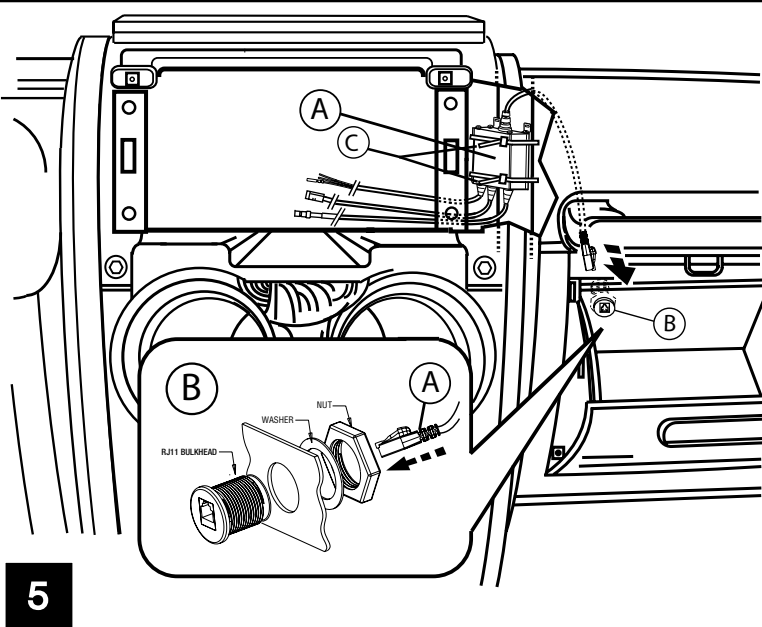
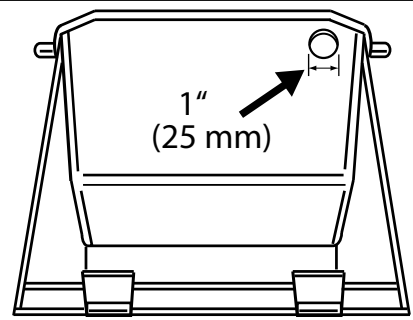

5

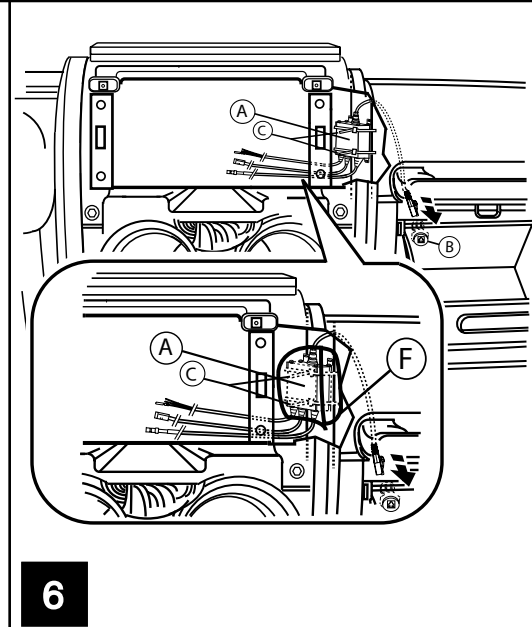

6

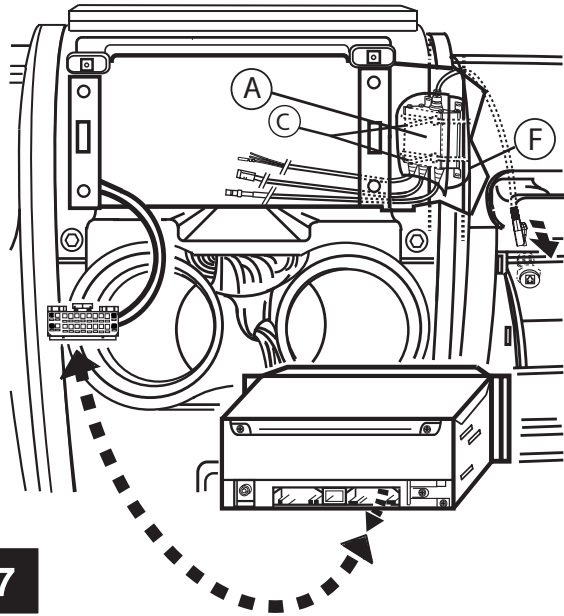

7

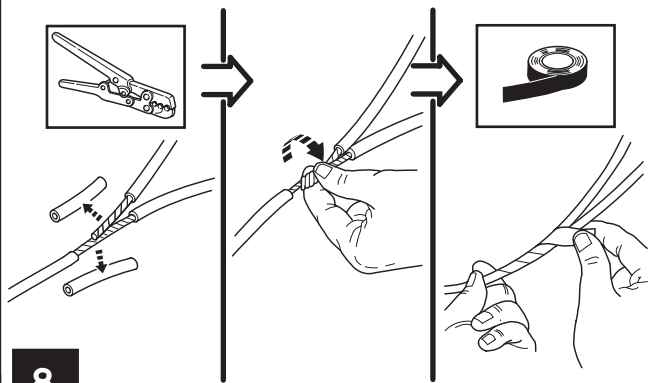
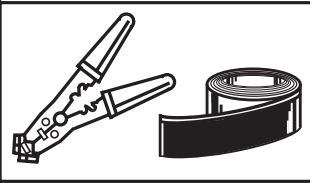

8

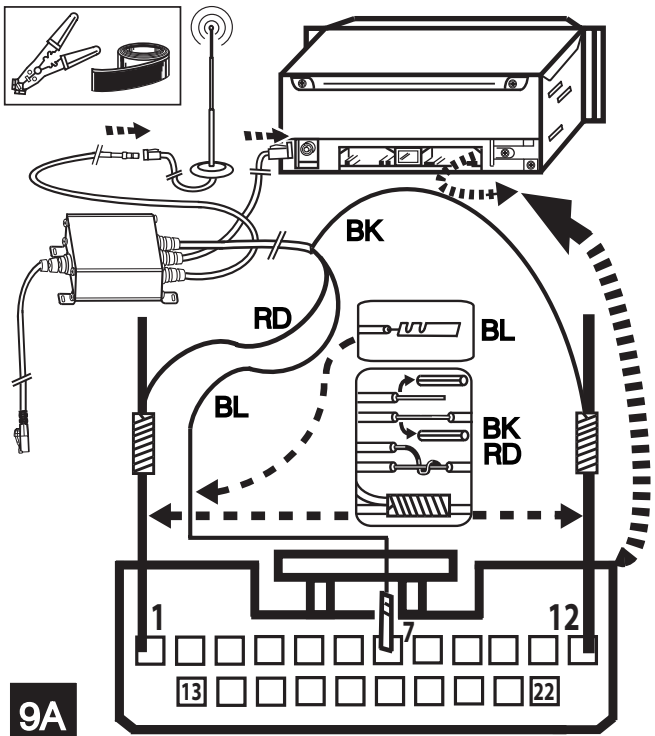

9A

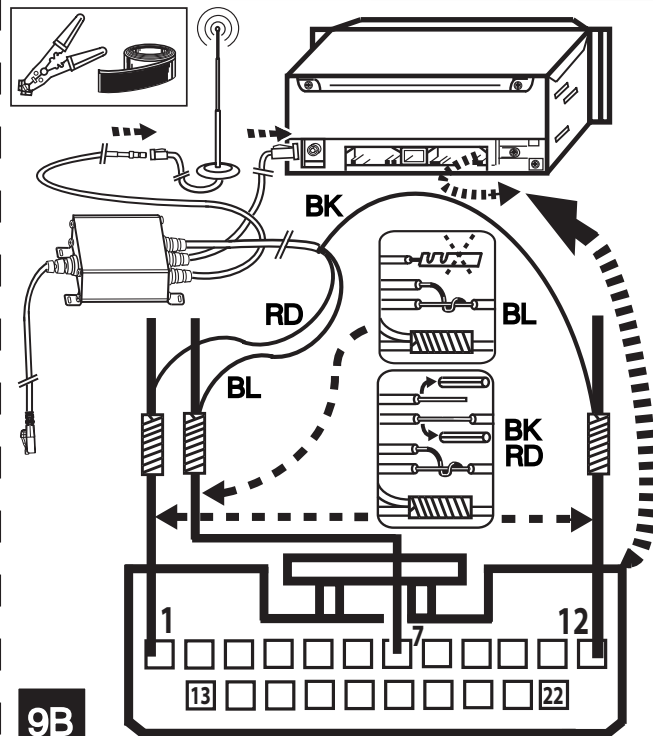

9B

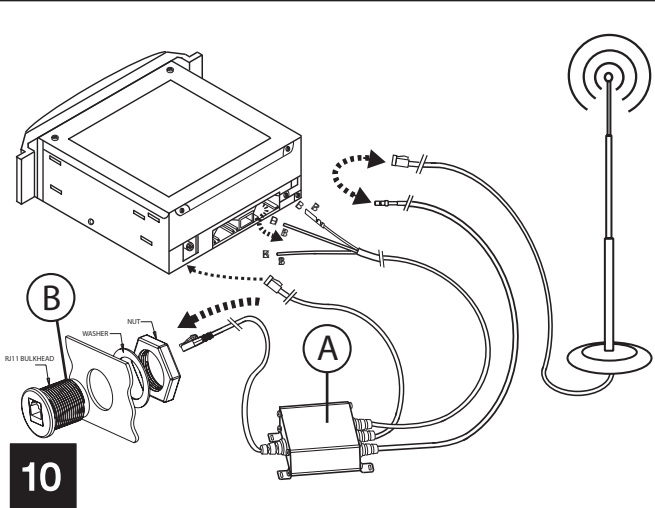

10

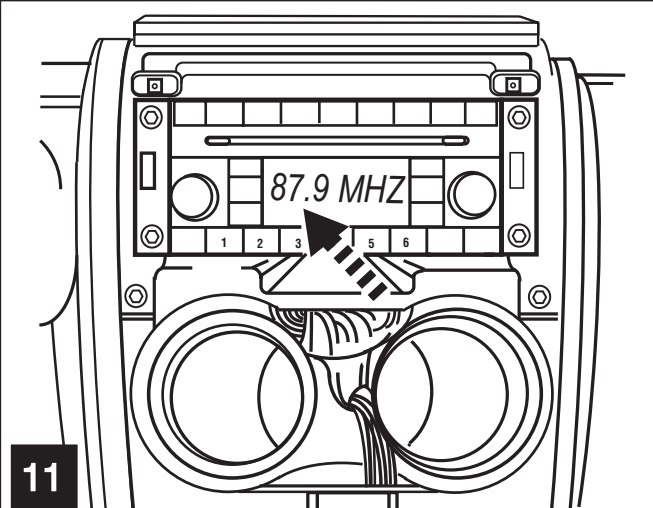

11

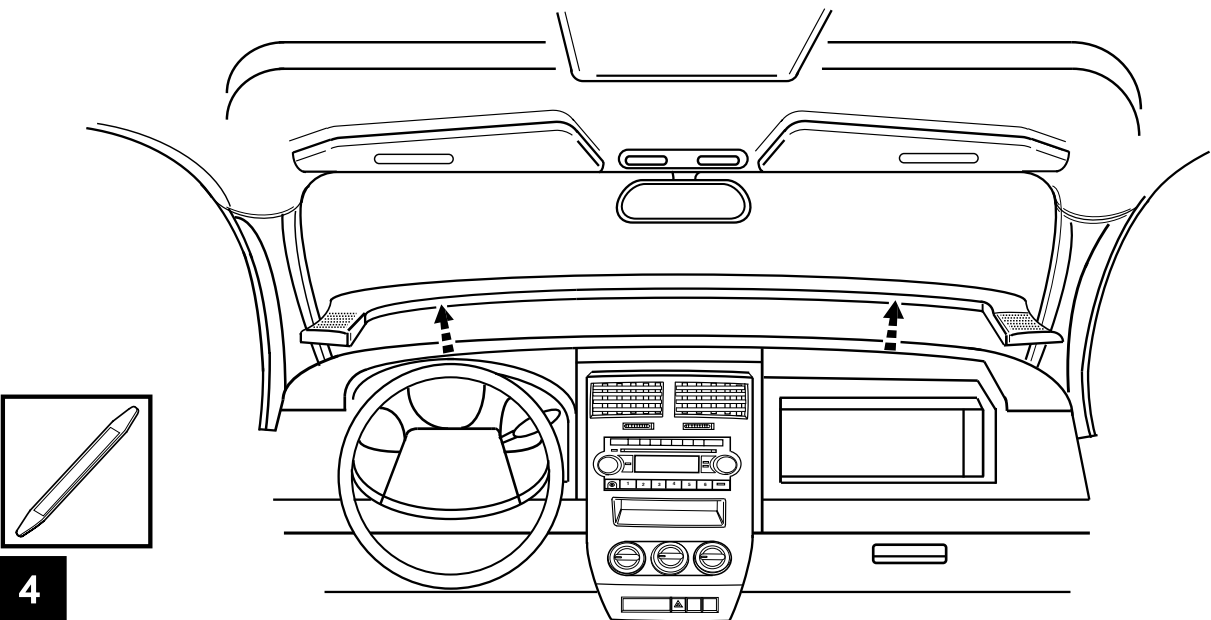
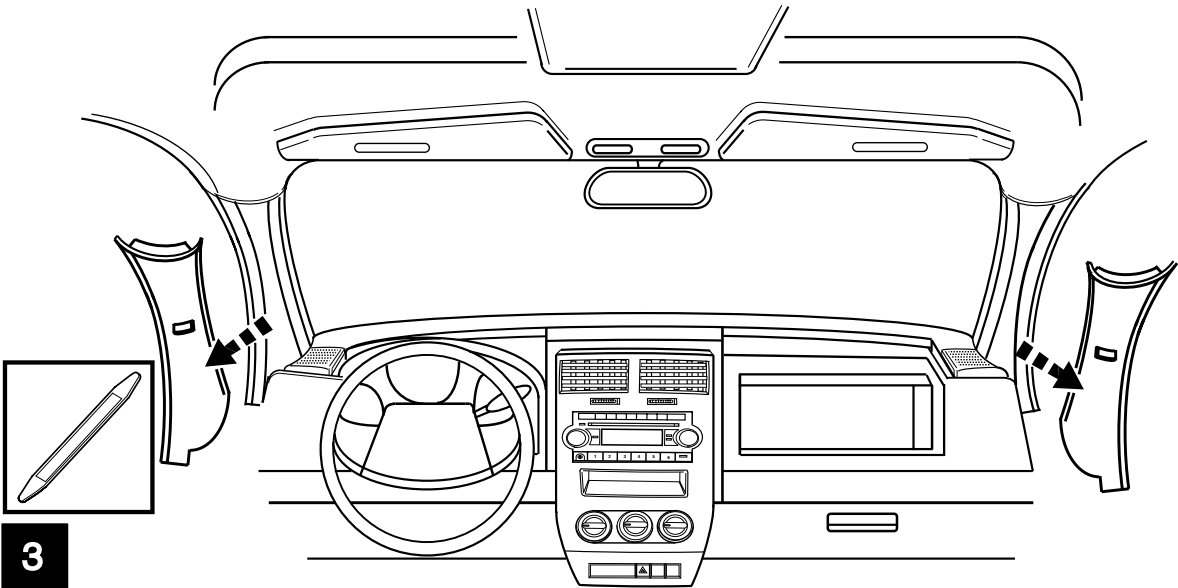
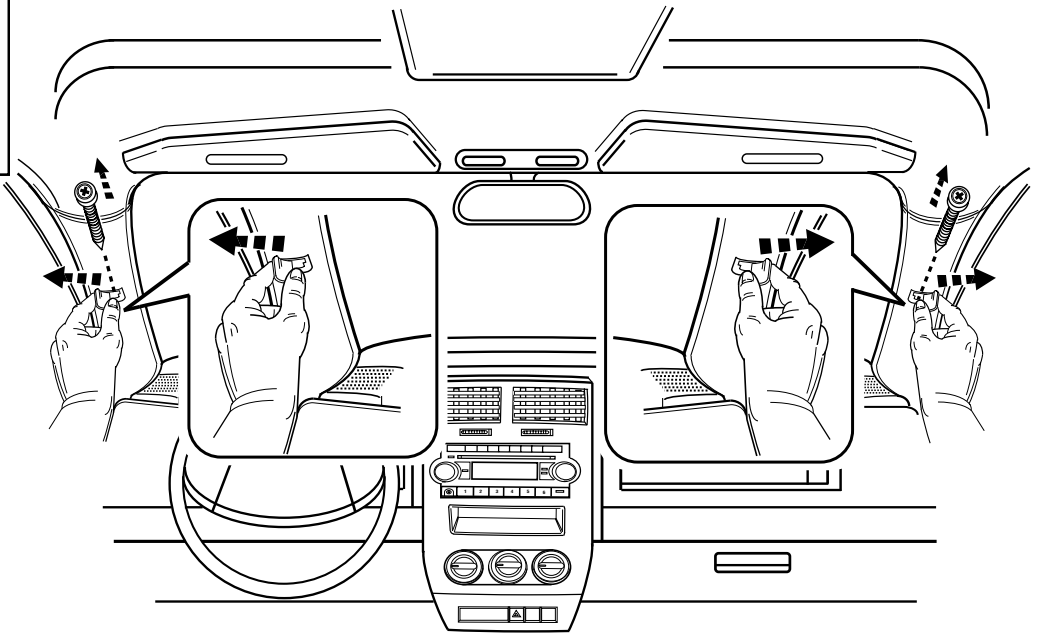
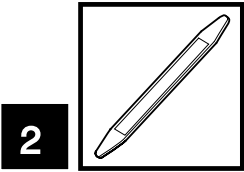
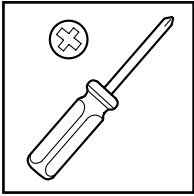
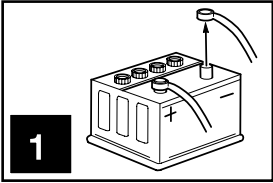

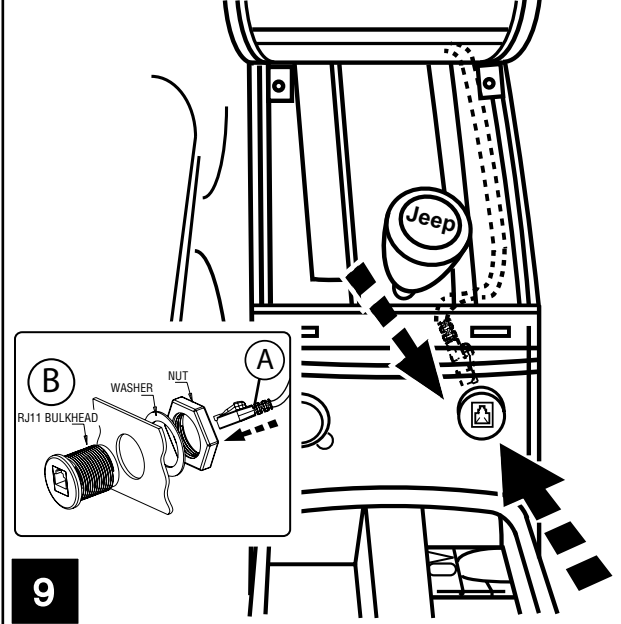
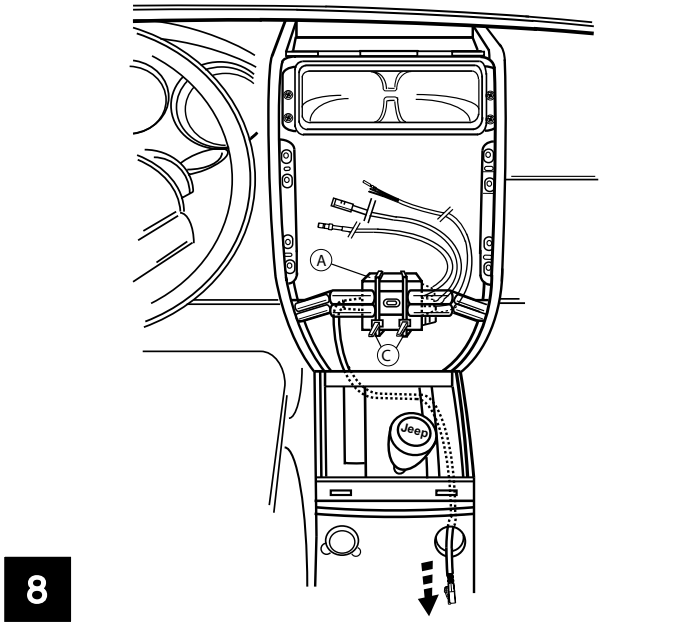
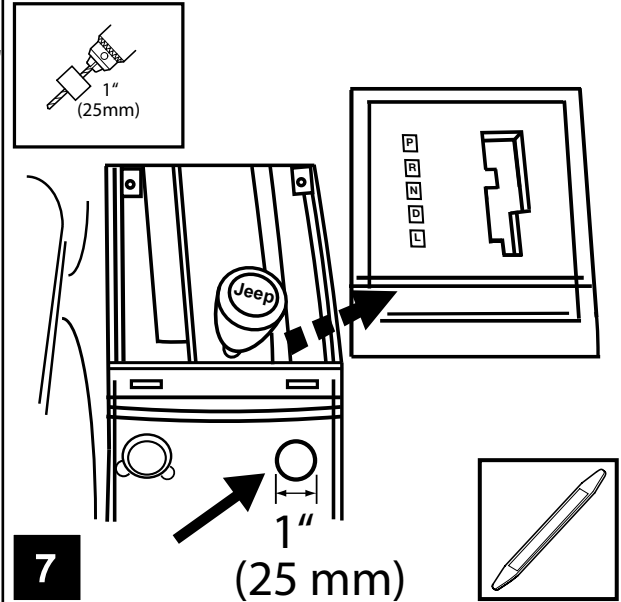
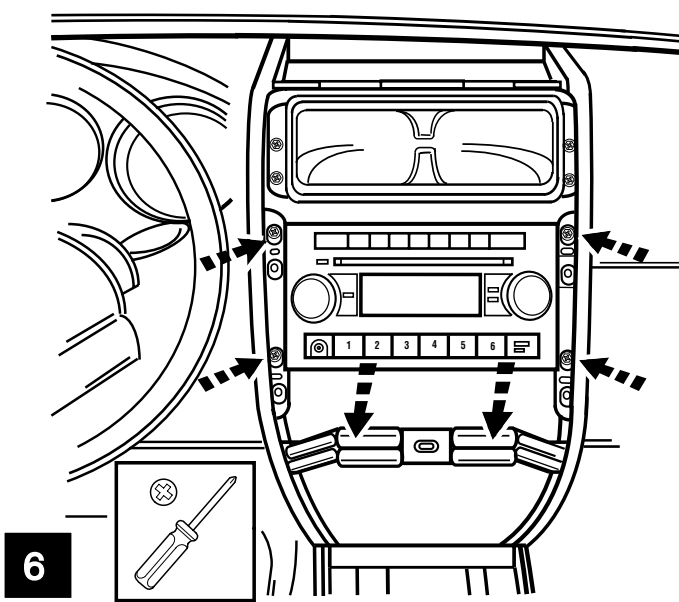
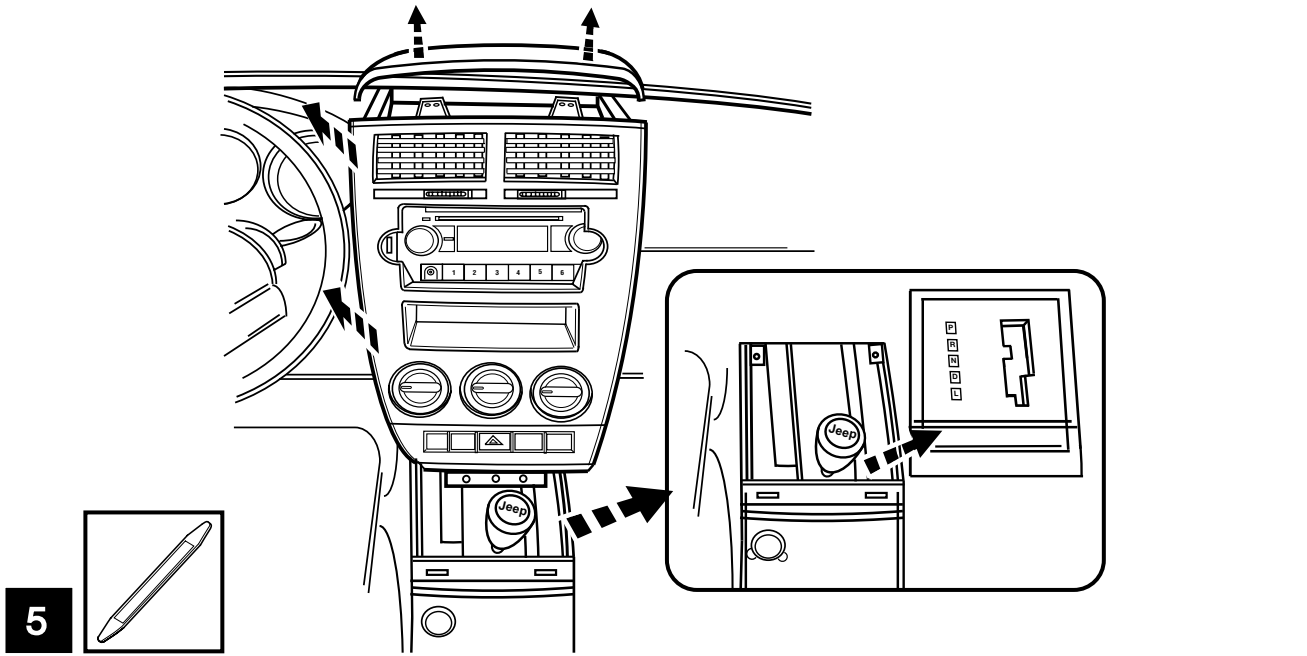

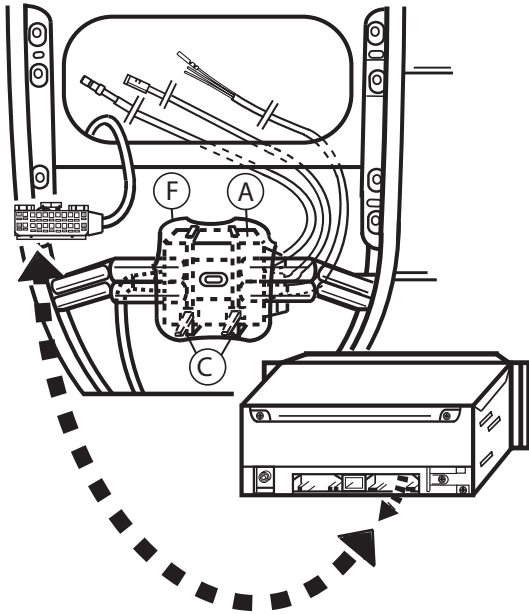

10

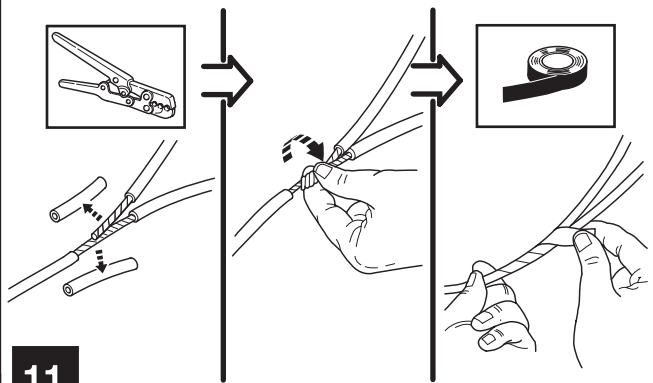
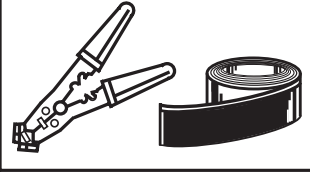

11

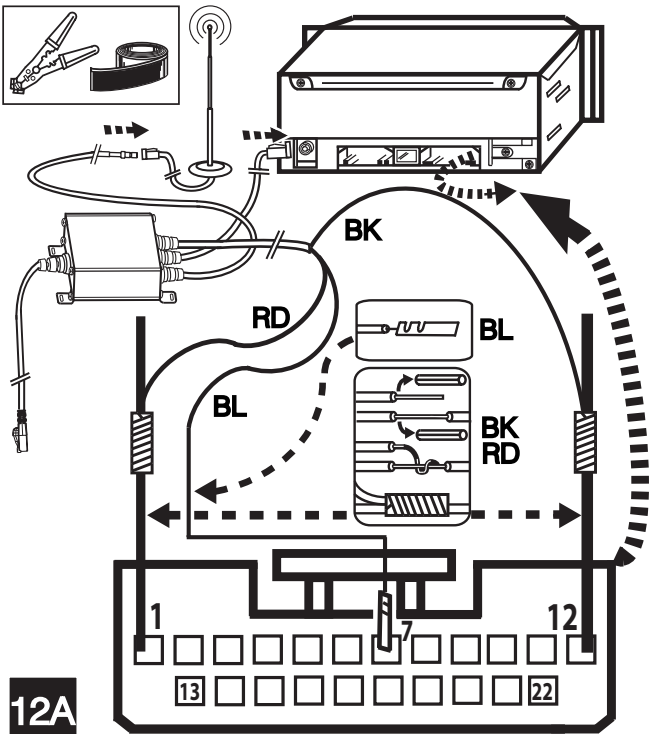

12A

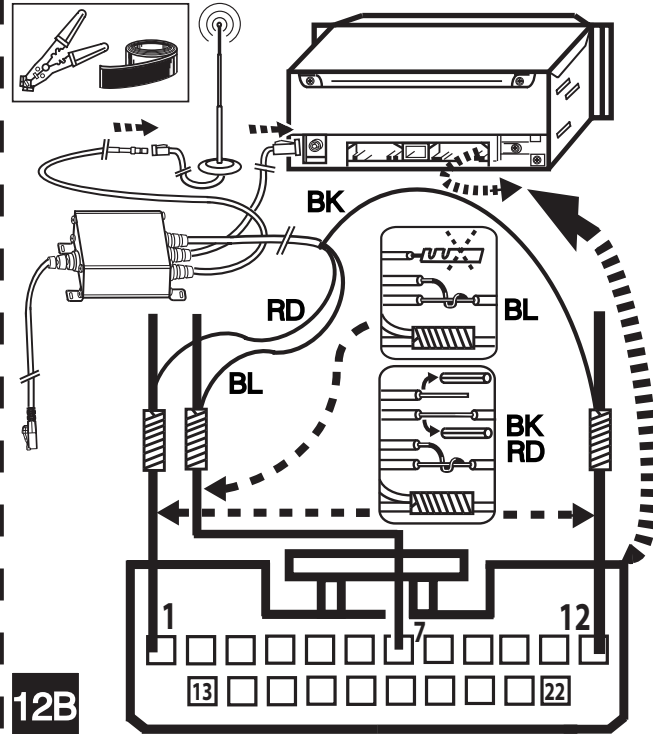

12B

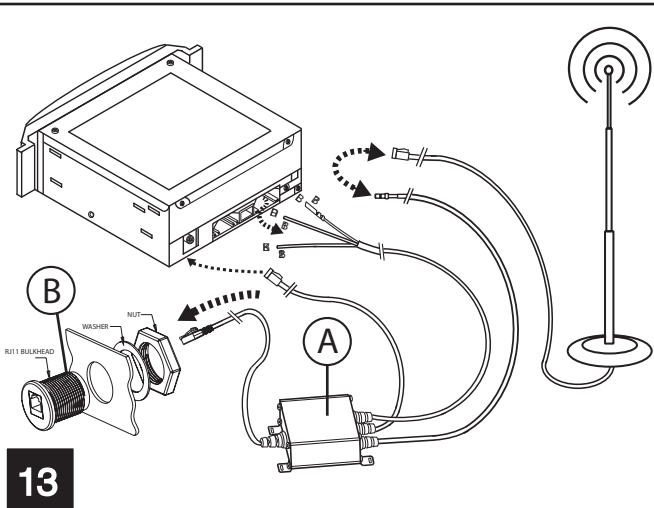

13

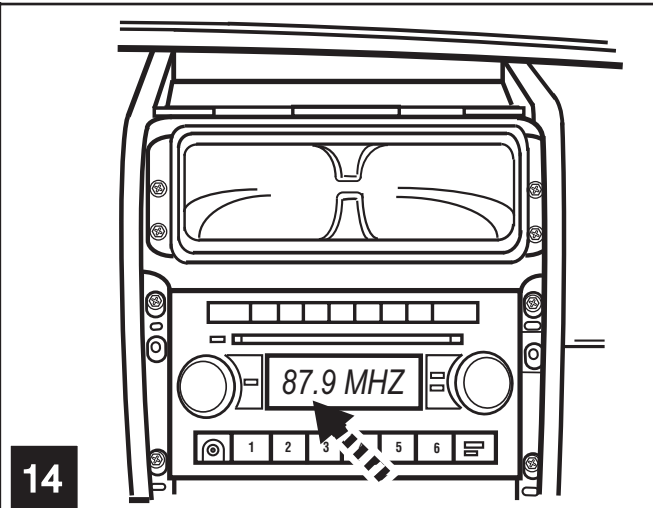

14