



OMIX-ADA, Inc.

460 HORIZON DR. SUITE 100 | SUWANEE, GA 30024 | PHONE: 770-614-6101 | FAX: 770-614-6069 | info@omix-ada.com

Part #11615.02

4-Door Rear XHD Armor Fenders

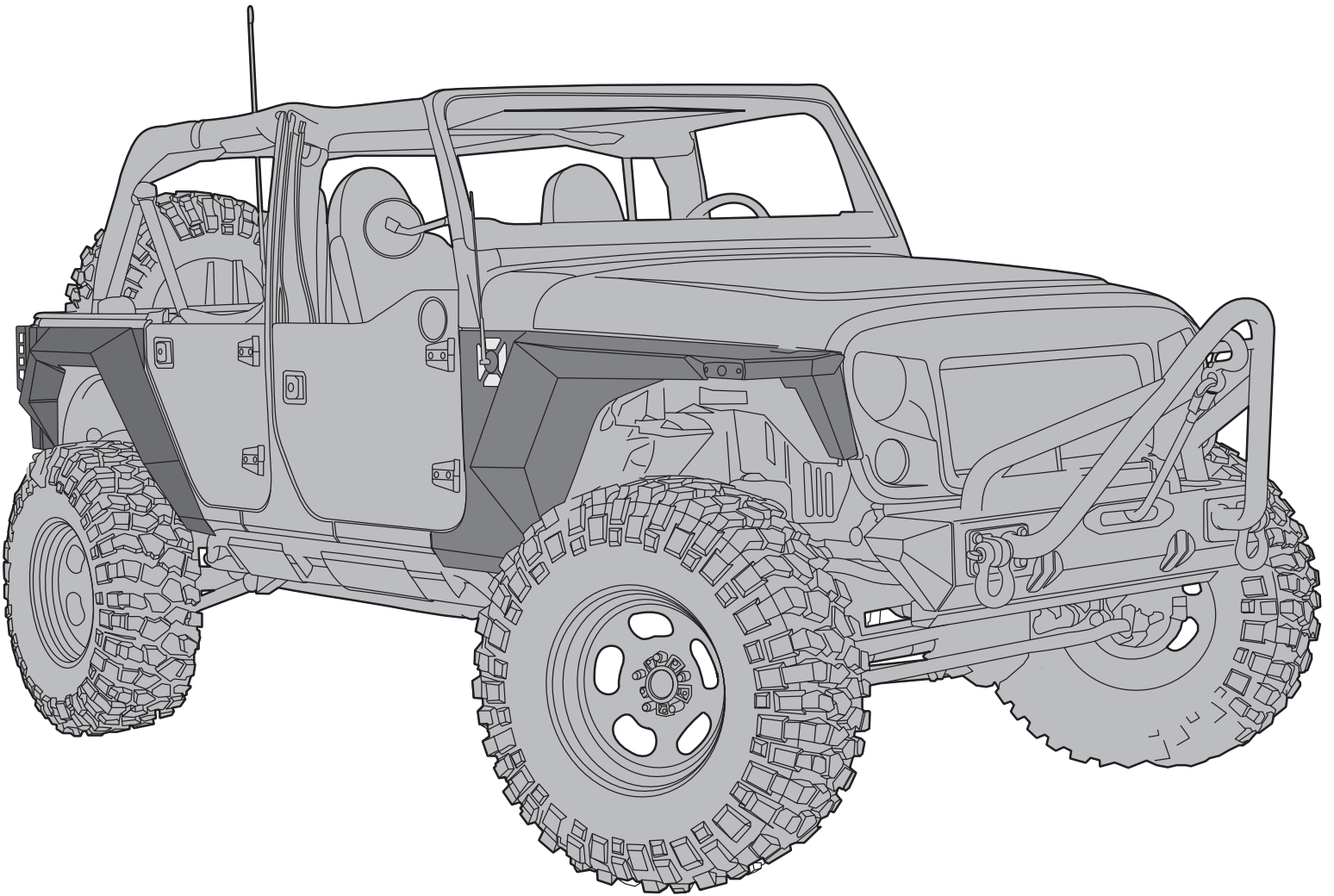



OMIX-ADA, Inc.

460 HORIZON DR. SUITE 100 | SUWANEE, GA 30024 | PHONE: 770-614-6101 | FAX: 770-614-6069 | info@omix-ada.com

4-Door Rear XHD Armor Fenders

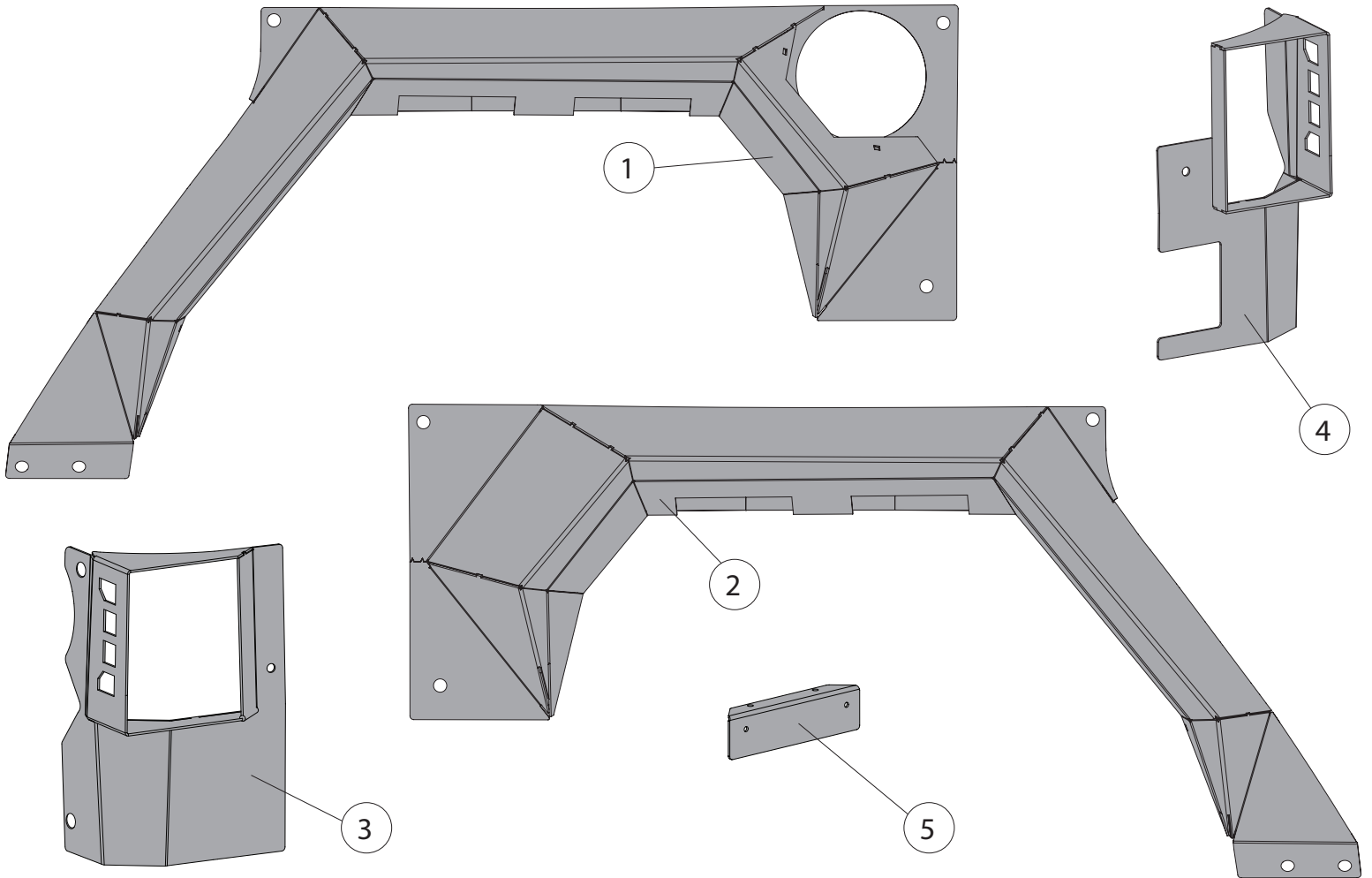

Components

- 1. Left Rear Fender (1)
- 2. Right Rear Fender (1)
- 3. Left Rear Guard (1)
- 4. Right Rear Guard (1)
- 5. License Plate Bracket (1)

OMIX-ADA® TECHNICAL SUPPORT

PHONE: M-F 8am - 5pm EST 1-800-449-6649 | EMAIL: techsupport@omix-ada.com

FOR WARRANTY INFORMATION VISIT: www.Omix-Ada.com



OMIX-ADA, Inc.

460 HORIZON DR. SUITE 100 | SUWANEE, GA 30024 | PHONE: 770-614-6101 | FAX: 770-614-6069 | info@omix-ada.com

4-Door Rear XHD Armor Fenders



Rubber Plate (2)

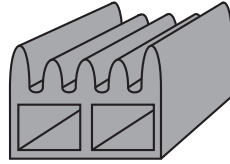

Thick Foam Strip (1)

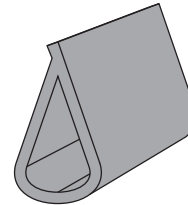

Thin Foam Strip (1)



No. 6 Screw (8)

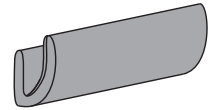

C-Style Trim (1)

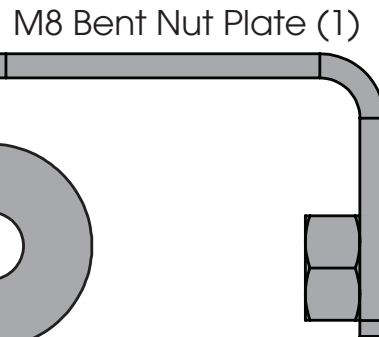

M8 Bent Nut Plate (1)



M8 Flat Nut Plate (4)

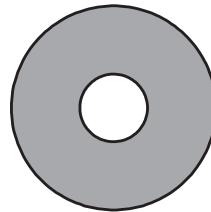

M8 Oversize Washer (12)



M6 Washer (4)

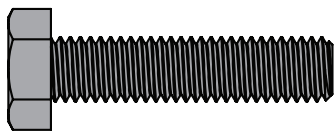

M8 Hex Bolt (1)

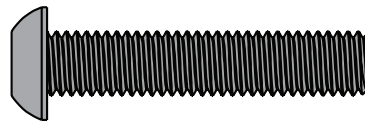

M8 Button Head Bolt (12)

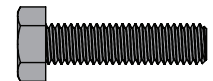

M6 Hex Bolt (2)

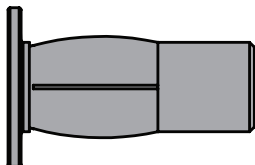

Slotted Rivet Nut (6)

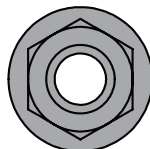

Rivet Nut Tool (1)

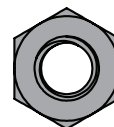

M8 Hex Nut (2)



M6 Hex Nut (2)



OMIX-ADA, Inc.

460 HORIZON DR. SUITE 100 | SUWANEE, GA 30024 | PHONE: 770-614-6101 | FAX: 770-614-6069 | info@omix-ada.com

4-Door Rear XHD Armor Fenders

1. Remove taillights, gas cap, fuel filler housing, side steps, and license plate housing from vehicle.

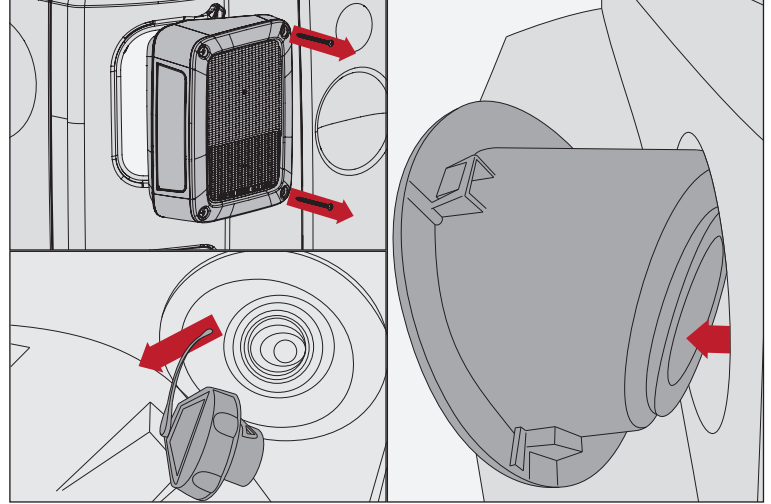

2. Remove OE flares and inner liners using a plastic clip tool.

NOTICE Painter's tape can protect vehicle paint from scratches during installation.

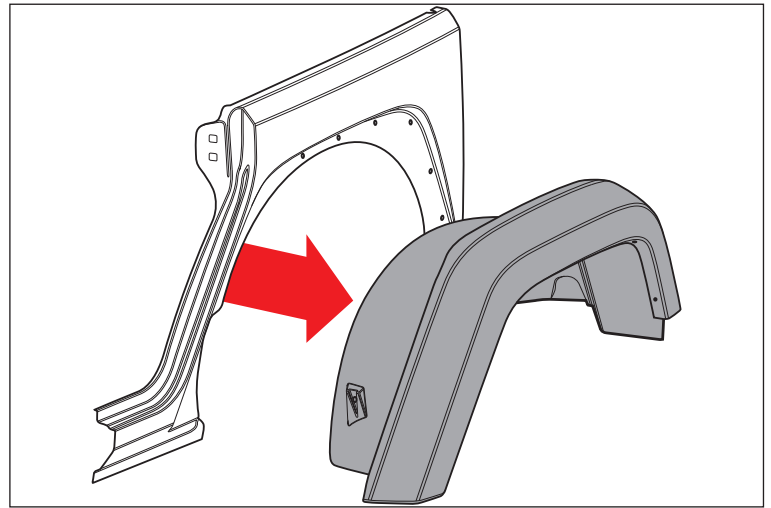

3. With a second person, align left rear Armor Fender using fuel filler hole and body lines as a guide. Align Rear Guard to Armor Fender and vehicle body to confirm correct fitment.

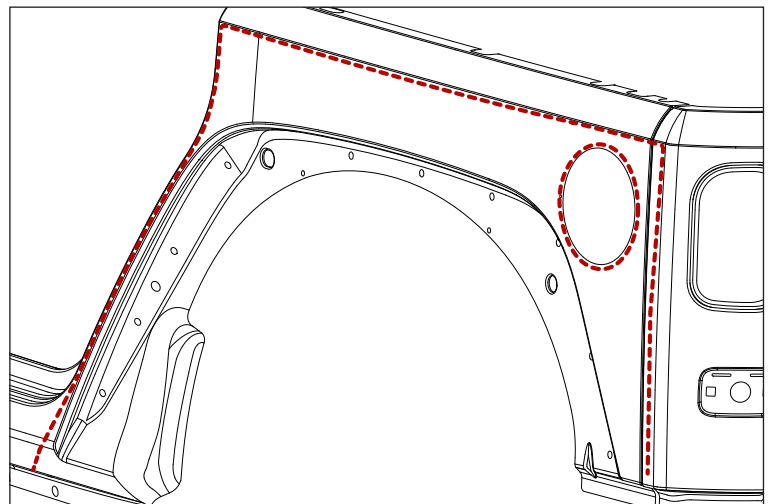



OMIX-ADA, Inc.

460 HORIZON DR. SUITE 100 | SUWANEE, GA 30024 | PHONE: 770-614-6101 | FAX: 770-614-6069 | info@omix-ada.com

4-Door Rear XHD Armor Fenders

4. Mark two rear holes. Set Armor Fender aside.

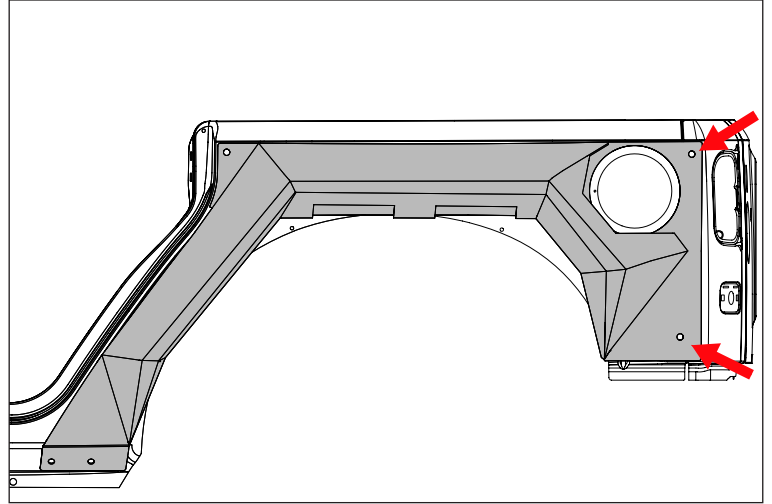

5. Clean inside of top fender edge with rubbing alcohol.

6. Peel 2-3 inches of tape backing away from Thin Foam Strip.

7. Apply Thin Foam Strip to top edge of fender with adhesive side contacting inside edge of fender.

8. Gradually remove tape covering while pressing remaining Thin Foam Strip into place. Do not stretch Thin Foam Strip

9. Trim excess Thin Foam Strip from end of fender.

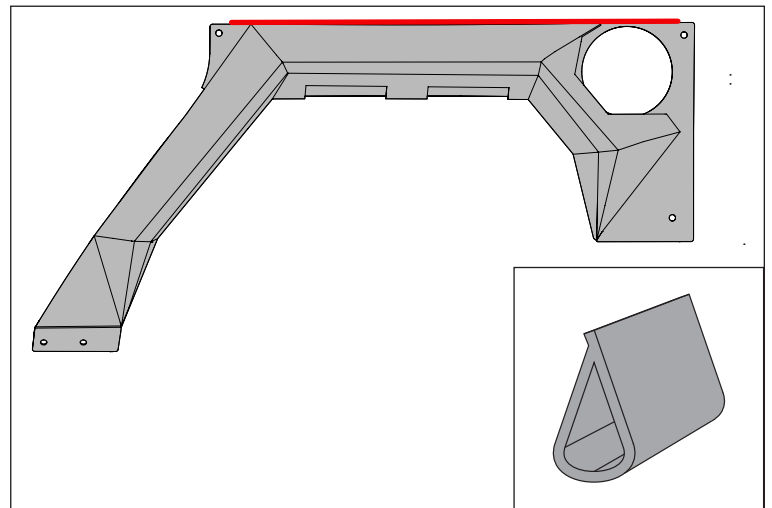

10. Using 1/8" drill, make a pilot hole at two marked locations. Using a step bit, open hole to 3/8".



WARNING

Thin sheet metal can cause standard drill bits to grab. This could cause injury.

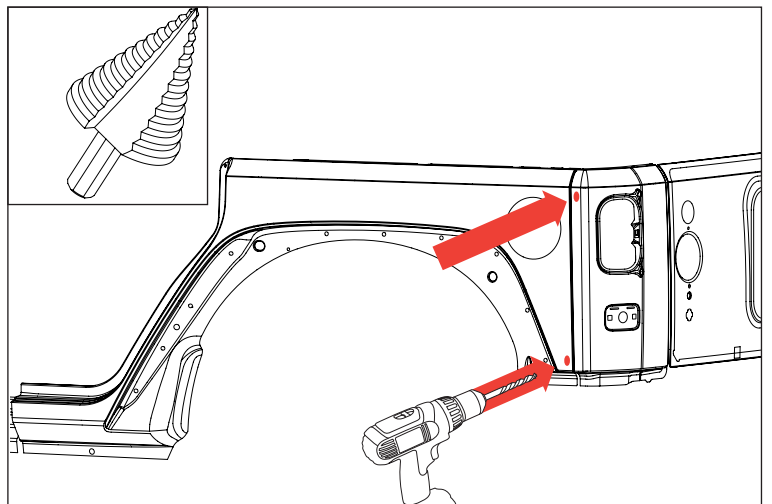



OMIX-ADA, Inc.

460 HORIZON DR. SUITE 100 | SUWANEE, GA 30024 | PHONE: 770-614-6101 | FAX: 770-614-6069 | info@omix-ada.com

4-Door Rear XHD Armor Fenders

11. Align Armor Fender with vehicle using previously drilled holes, fuel filler hole, and body line. Mark next three holes.

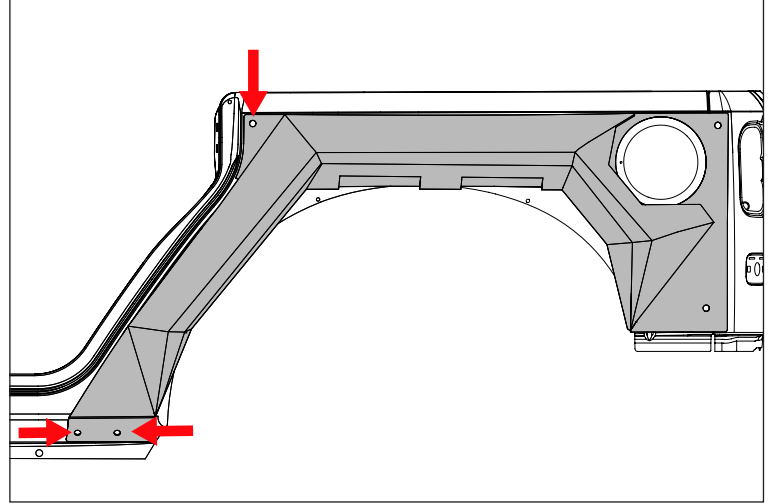

12. Using 1/8" drill, make a pilot hole at three marked locations. Using step bit, open holes to 1/2".



WARNING

Thin sheet metal can cause standard drill bits to grab. This could cause injury.

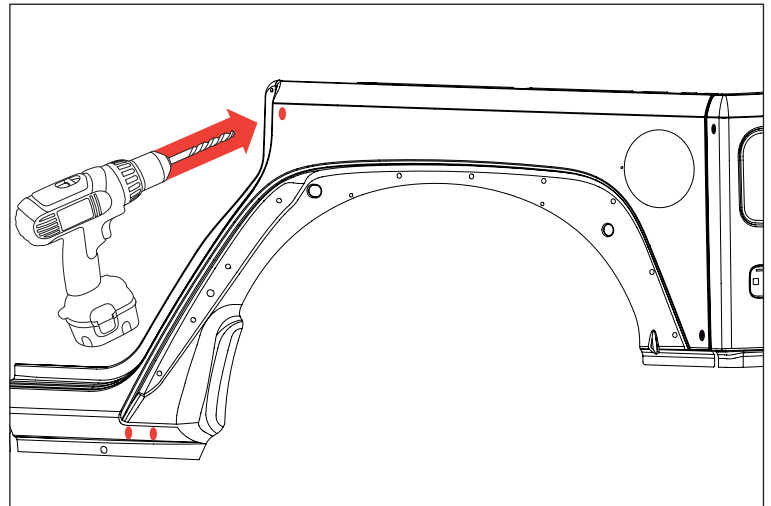

13. Insert Slotted Rivet Nuts into newly drilled holes.

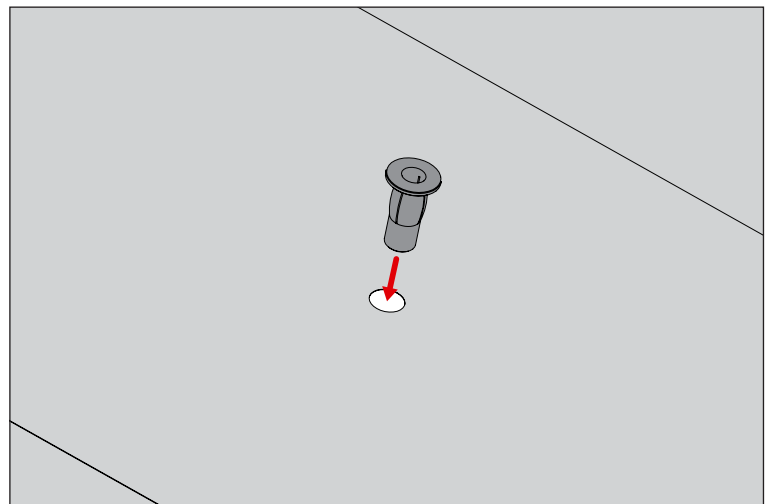



OMIX-ADA, Inc.



460 HORIZON DR. SUITE 100 | SUWANEE, GA 30024 | PHONE: 770-614-6101 | FAX: 770-614-6069 | info@omix-ada.com

4-Door Rear XHD Armor Fenders

14. Using Rivet Nut Tool and M8 Hex Head Bolt, collapse Slotted Rivet Nuts into vehicle panel. Use a wrench to prevent Rivet Nut Tool from spinning while turning M8 Hex Head Bolt. There will be slight resistance until Slotted Rivet Nut is fully collapsed. Slotted Rivet Nut can be damaged if over tightened.

NOTICE If Slotted Rivet Nut is spinning, apply more force to Rivet Nut Tool.

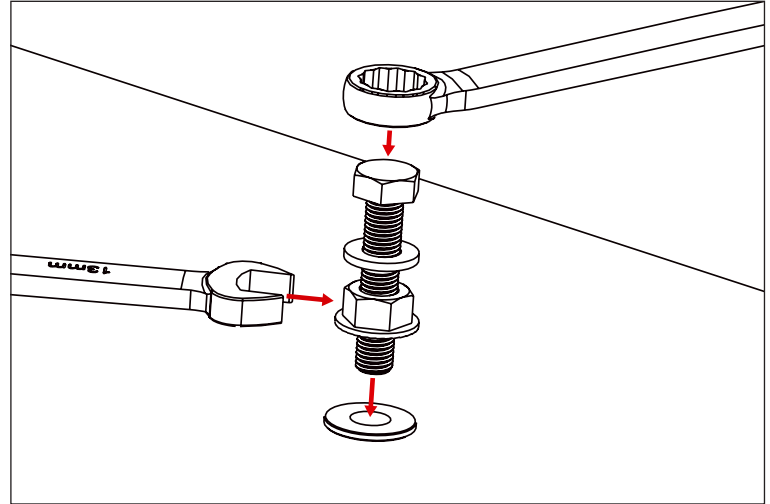

15. Loosely attach Left Rear Armor Fender to vehicle using supplied M8 Button Head Bolts, M8 Washers, and collapsed Slotted Rivet Nuts.

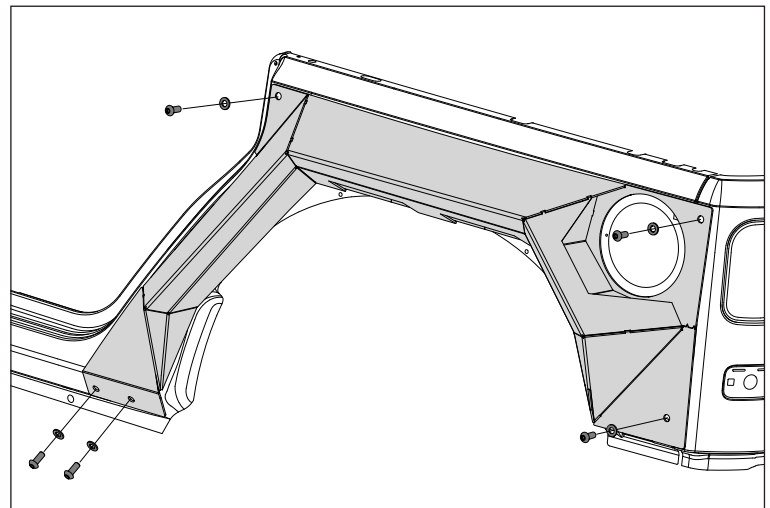

16. Mark vehicle's rear wheel well along path of Armor Fender. Remove Armor Fender from vehicle.

18. Attach Thick Foam to vehicle along previously marked path.

19. Re-attach left rear Armor Fender to vehicle. The Thick Foam will fill any gaps between vehicle and Armor Fenders.

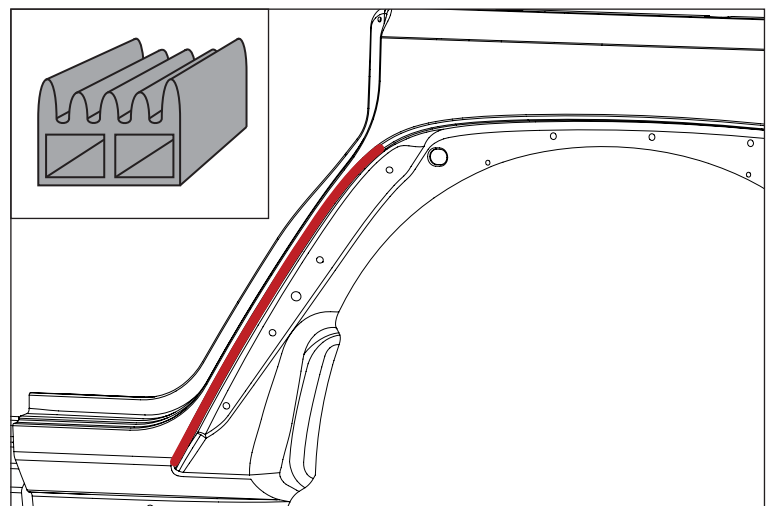



OMIX-ADA, Inc.

460 HORIZON DR. SUITE 100 | SUWANEE, GA 30024 | PHONE: 770-614-6101 | FAX: 770-614-6069 | info@omix-ada.com

4-Door Rear XHD Armor Fenders

20. With a second person, position left Rear Guard flush on vehicle, using Armor Fender and body lines as a guide.

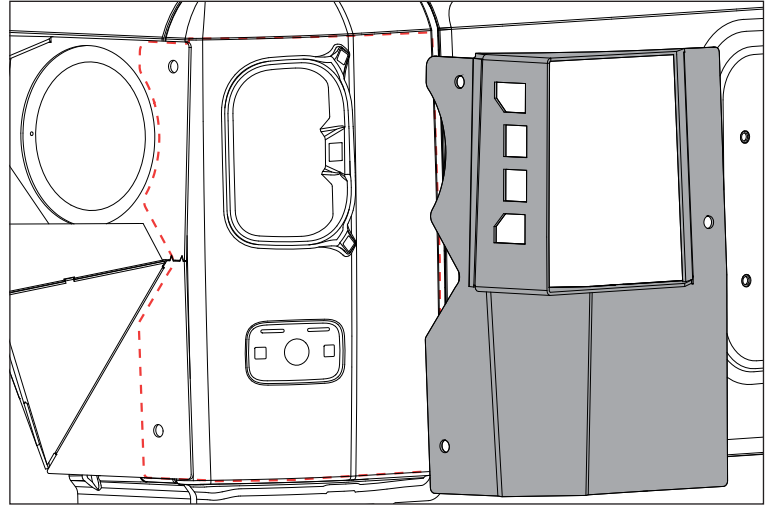

21. Mark mounting hole.

22. Using a small 1/8" drill, make a pilot hole at marked location. Using a step bit, slowly open pilot hole to 3/8".

WARNING Thin sheet metal can cause standard drill bits to grab. This could cause injury.

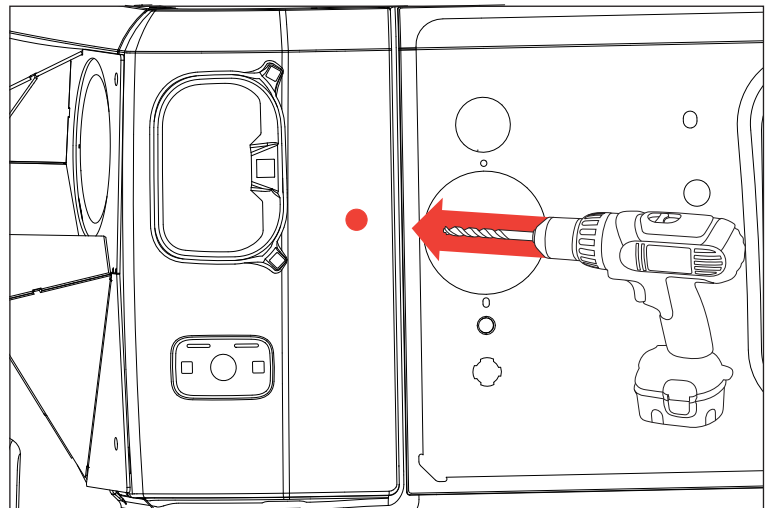

23. Slide C-style Trim onto Rear Guard as shown.

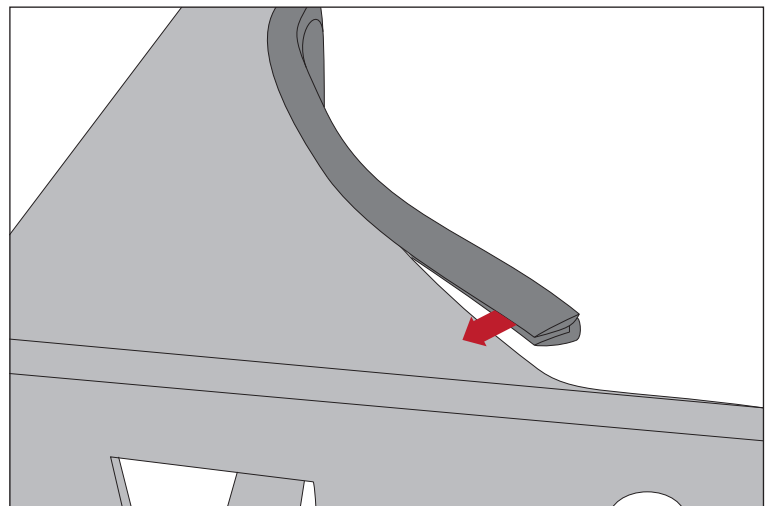



OMIX-ADA, Inc.

460 HORIZON DR. SUITE 100 | SUWANEE, GA 30024 | PHONE: 770-614-6101 | FAX: 770-614-6069 | info@omix-ada.com

4-Door Rear XHD Armor Fenders

24. Attach left Rear Guard and left Armor Fender to vehicle using M8 Nut Plates, Bolts, and Washers.

25. Attach left Rear Guard to vehicle using M8 Bolt, Washer, and Nut.

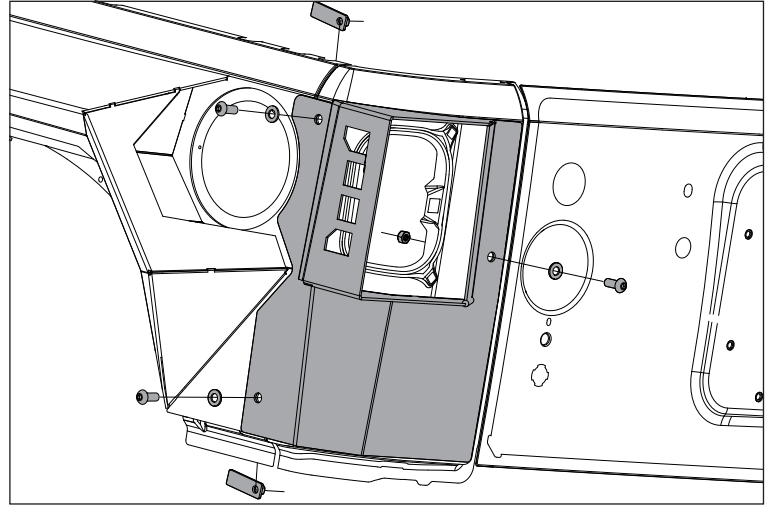

26. Repeat steps 3-24 for right side.

27. Attach right Rear Guard to vehicle using M8 Bolt, Washer, and Bent Nut Plate.

28. Reattach taillights, gas cap, and fuel filler housing.

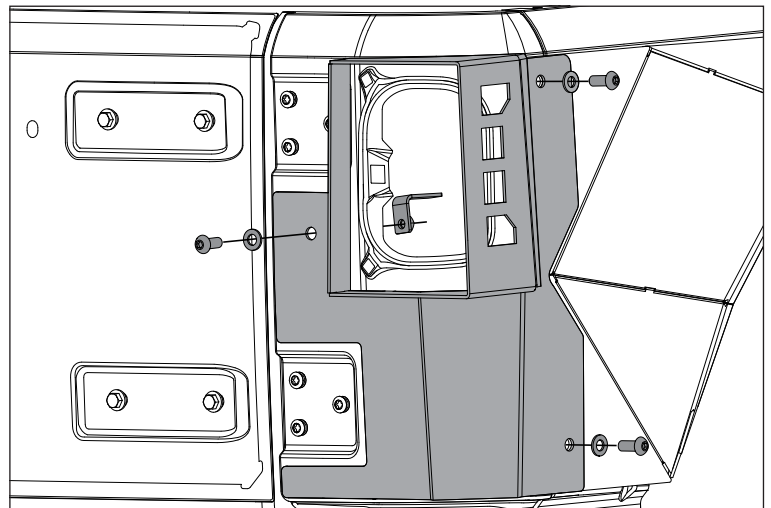

NOTICE It is recommended to use LED license plate bolts to replace the OE License Plate Light.

29. Using supplied M6 hardware, attach License Plate Bracket to left Rear Guard.

NOTICE A small hole can be drilled in Left Rear Armor Fender just behind License Plate Bracket for License Plate Light wires.

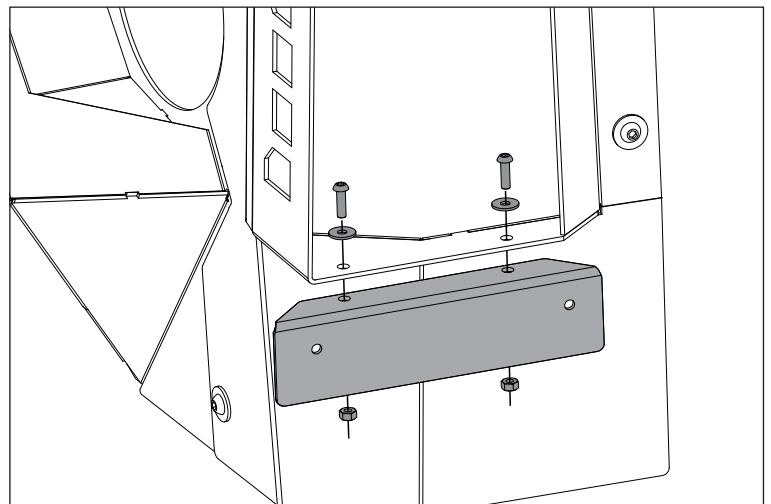



OMIX-ADA, Inc.

460 HORIZON DR. SUITE 100 | SUWANEE, GA 30024 | PHONE: 770-614-6101 | FAX: 770-614-6069 | info@omix-ada.com

4-Door Rear XHD Armor Fenders

NOTICE Skip to step 33 if using Rugged Ridge Inner Fender Liners (#11620.50). If using OE liners, proceed to step 30.

30. Attach rear fender liner. Mark a line that follows edge of fender. Cut line marked.

cutting/sharp Edge Hazard: Cut carefully using gloves and eye protection.

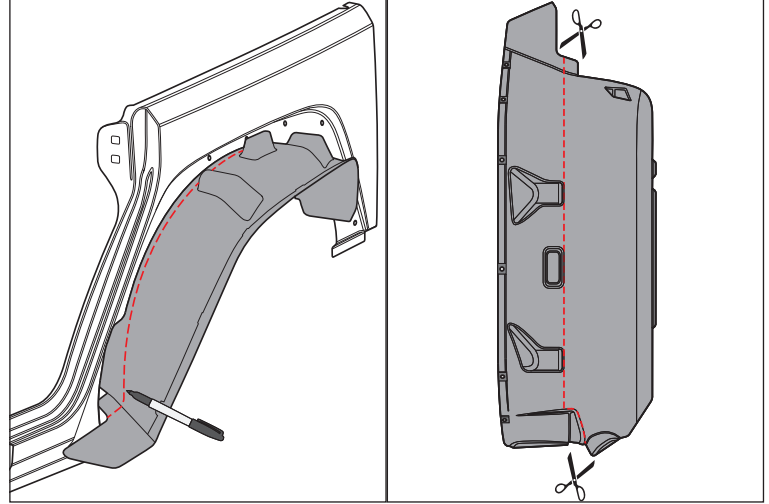

31. Align rubber plate to fender liner.

32. Using sheet metal screws, attach rubber plate to fender liner. Next, tuck sheet rubber plate into Armor Fender.

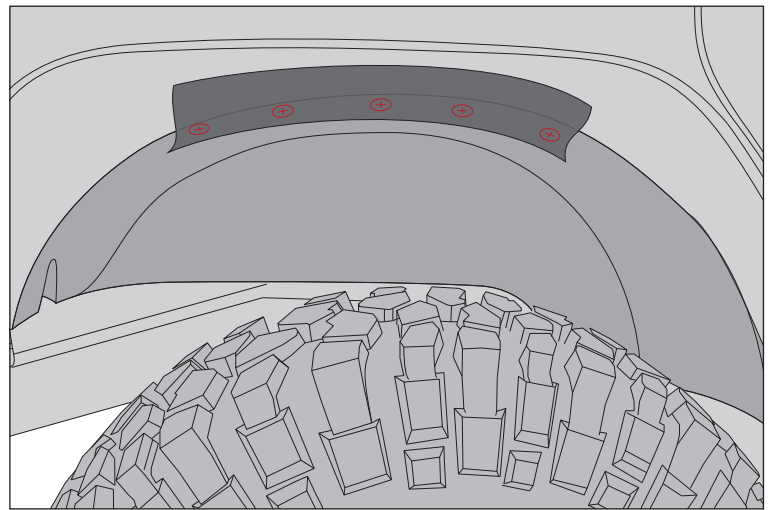

33. Using hardware included with Rugged Ridge Inner Fender Liners, attach rear fender liners.

