



WIRE HARNESS INSTALLATION INSTRUCTIONS

For Installing:

Part #10110 – 12 Circuit Universal CJ Jeep™ Harness (1975-86)

Manual #90513

Perfect Performance Products, LLC

Painless Performance Division

2501 Ludelle Street

Fort Worth, Texas 76105-1036

800-423-9696 phone

817-244-4024 fax

Web Address: <http://www.painlessperformance.com>
E-Mail Address: <mailto:tech@painlessperformance.com>

NOTE :

If your vehicle has an existing harness, you will want to retain it for the possible re-use of various Pigtails & Connector housings, particular to your application.

Included in this kit is a sheet of pre-printed labels, to assist in identifying of connections as the existing harness is removed from the vehicle.

If you do not have an existing harness, there is a package of terminals included with the harness that will enable you to make most of the connections needed. Replacement lighting pigtails & sockets can be readily obtained from your local parts distributor

The 10110 Painless harness is designed to be a complete chassis harness with most of the plugs, sockets and connectors needed for factory equipped Jeep CJ7 vehicles. The engine compartment wiring is not engine or charging system specific due to the large number of modified vehicles on the road. **Due to this variance computer connections are not included.**

The harness is made in three parts:

- A. The dash section, which includes all the wiring for the fuse block, instruments, the dash illumination and switches. Note illustration “A”
- B. The engine section, which includes the front lighting along with the basic engine wiring. Note illustration “B”
- C. The tail section, which includes the wiring for the rear of the vehicle. Note illustration “C”

All wiring in the system is factory color coded as near as possible for easy tracing and installation. The wires also have been labeled to help with your installation. The fuse block is the factory original style, which also uses the factory style bulkhead connector.

***NOTE:** The insertion order of the wires in the 10110 fuse block and bulkhead connector is not the same as the original equipment harness and there for they are not interchangeable.*

At the end of these instructions are some general diagrams on charging and starting circuits to help in the proper hookup of the engine section wiring.

Step 1

Contents of the 10110 Painless Kit

Check the package to insure you have all the following components of the 10110 kit.

The engine harness

The fuse block and dash harness assembly

The rear harness

The parts bag which includes flashers, terminals and hardware

The maxifuse assembly

These instructions-Manual 90513

Step 2

Pre-installation guidelines

Lay out the harnesses beside the vehicle to get an idea where all the wires are to be routed and later attached.

Make notes of areas where the harness will need to be supported and protected from sharp edges, moving objects or extremely hot objects.

Be sure that care is taken not to remove any special wiring in the engine compartment that may attach electronic equipment together, such as the distributor and module or alternator and regulator. Refer to the drawings of the engine compartment accessories, in the rear of this manual, for assistance.

In the following steps, the connectors and individual wires will be referred to by letter and circuit number. These will match the drawings of each different harness section.

The following glossary of wire color codes will aid in your installation.

BK – BLACK	RD – RED	WT – WHITE	GY - GRAY
PK – PINK	OR – ORANGE	TN – TAN	LTGN – LIGHT GREEN
BL – BLUE	GN – GREEN	BN – BROWN	LTBL – LIGHT BLUE
YL – YELLOW	PU – PURPLE		

The first color of the wire in multiple colors, is the main color and the second is the stripe color. Rd/wt would indicate a red wire with a white stripe.

***Important;** An “X” marked on the end of a wire, in an illustration, means the wire has no terminal on it and must be cut to length before terminating and attaching.*

CAUTION: Be sure the battery cables are not attached to the battery until the instructions say to do so!

Step 3

Installing the fuse block and dash harness

1. Mount the fuse block in the factory hole in the firewall using the original bolts or ones supplied. Route the remaining harness up and over the brake pedal support.
2. Plug the dimmer switch connector “A” on to the dimmer switch
3. Connector “C” is provided for vehicles with dome lights or may be used for future installation of dome lights. The black wire is ground and the orange is power.
4. The tail harness connector “B” will be used later when the tail harness is installed.
5. The black wire with no terminal on the end “Emer. Brake” is to be attached to the brake switch on the park brake lever.
6. Plug the headlight connector “D” on to the headlight switch. Attach the ground wire to a good ground and mount the dash light fuse holder “LL” to a solid surface.
7. Route the black and white connectors for the ignition switch “H and I” to the steering column and plug them into the switch. The white connector plugs in first and then the black.
8. Plug the turn signal connector “G” on to the flat connector by the ignition switch. The flat column connector may have more wires in it than the new harness connector, only those wires in the new connector will be needed.
9. Plug the brake light connector “F” on to the brake light switch located near the brake pedal.
10. Plug the heater switch connector “E” on to the heater fan control at the top of the dash.
11. Plug the dash control illumination connectors “KK” on to each light in the dash. The extra orange and black wire is for use with an extra gauge or clock.
12. Remove the dash cluster assembly and plug in the panel lights “MM” into the cluster. These lights fit very snugly, so extra pressure may be needed to get them snapped in.
13. Plug in the high beam indicator light “M”, the left turn indicator light “K”, the right turn signal indicator light “L”, the brake warning indicator light “O” and the 4 wheel drive indicator light “R” into the dash cluster. **Note:** Indicator Lights are labeled per function.
14. Install the #721 purple/white temperature gauge sender wire on the single long post on back of the temperature gauge.

NOTE: These terminals were originally a push on terminal and now are an eyelet terminal. Nuts to attach each terminal are provided in the parts kit.

15. Install the #739 pink wire on the fuel gauge post closest to the glove box and secure with a nut.
16. Install the red wire on the remaining fuel gauge post and secure with a nut.
17. Attach the black wire to a good ground such as a cluster mounting screw.
18. Install the #735 yellow wire of the voltmeter to the driver side terminal and the black wire to the passenger side terminal of the voltmeter and secure with nuts.
19. Install the #722 purple oil gauge wire to the driver's side terminal, the black wire to the center terminal and the red wire to the passenger side terminal of the oil gauge and secure with nuts. Reinstall the dash cluster assembly.
20. Plug the wiper switch connector "JJ" on to the terminal closest to the steering column of the wiper switch and the washer connector "NN" on to the terminal closest to the dash cluster of the wiper switch. NOTE: The three original wires from the center of the switch to the wiper motor will need to be reused.
21. Plug the heater resistor connector "J" on to the resistor at the heater. In some cases the connector may need to be removed and the original connector installed on the new harness. If this is necessary, be sure to make note of the color code order of the connector.

STEP 4

Installing the dash accessory wires

NOTE: Not all vehicles will use any or all of these wires.

1. The #702 brown wire marked "a/c comp" attaches to the thermostat output terminal of the air conditioning thermostat control switch.
2. The #759 white/red wire marked "clock" is the power wire for the electric clock.
3. The #723 purple wire marked "tach" is from the distributor for tachometer signal.
4. The #703 red wire marked "cig lighter" is the power wire for the cigarette lighter or accessory port.
5. The #741 blue wire marked "radio" is the power wire for a radio.
6. There are two gray/white wires numbered 701 and 706 that are to control an electric fan relay when a fan switch is located in the dash. The #706 wire marked "fan switch power" is the power wire for the switch, from the fuse block and the #701 wire marked "elect fan" is the wire that goes to the fan relay from the switch. If no dash switch is used but an electric fan is used, connect these wires together for activation power to be transmitted to the fan relay.

NOTE: Wire #701 Gry/Wht is not a power wire for a fan. This wire is an activation wire for a fan relay. See Diagram #2

STEP 5

Installing the front/engine harness

1. Attach the engine bulkhead connector to the fuse block connector and tighten the small bolt in the center to secure the two together. Take care not to over tighten the bolt. Harness connections will start here and move outward toward the front of the vehicle. Be sure to attach the harness with clips or wire ties when finished to prevent it from sagging, rubbing a moving part or getting too close to the exhaust system.

NOTE: A small amount of grease applied to the bulkhead terminals will aid in coupling the connectors together.

2. Terminate the black wire with a ring terminal and attach to a good ground.
3. Plug in the two-wire connector "BB" to the brake failure switch.
4. The 4 wires marked "backup switch neutral safety" are attached as follows;

Mopar style 3 terminal switch;

Red #758 is ignition power, black #783 is relay ground and white/black #756 is back-up lights output.

All other style switches;

The #758 red wire and the #756 white/black wires attach to the back-up light switch.

The black #783 wire will not be used.

NOTE: The type of solenoid your vehicle is equipped with determines the proper hookup of the wiring. Please refer to the illustration that matches your vehicle and use it as a guide for wire connections.

5. The #720 red/white wire marked "coil +" attaches to one side of the ballast resistor and the remaining length of wire attaches to the remaining terminal and goes to the "+" side of the ignition coil on Motorcraft, Prestolite and standard point style ignition systems. On GM HEI ignition systems the red/white wire attaches to the "BAT" terminal at the distributor. **The Brn #781 will be used only when a Ballast Resistor is being used. It will be installed to the starter relay on the "I" post and goes to the coil "+" side of the coil. This is a Ballast Bypass wire to be used only when a Ballast Resistor is being used.**
6. The #782 green wire marked "coil -" (used only with Motorcraft and Prestolite ignition systems) and #723 purple wire marked "tach", if a tachometer is used,
7. The #724 red/blk wire marked "horn" attaches to the horn. ("OO" on illustration "B")
8. The 788 yellow wire marked "washer motor" attaches to the wiper washer. ("QQ" on illustration "B")
9. The #754 red wire marked "choke" attaches to the electric choke if so equipped.
10. The #780 tan wire marked "heater motor" plugs on to the heater motor. ("II" on illustration "B")

STEP 6

Wiring the engine and starter

A. The starter solenoid group of wires.

1. The #719 Lt.Blu wire marked “start” attaches to the “S” terminal of the starter solenoid on Ford and GM style solenoids (refer to illustrations “H” & “G” respectively) and the “ST” terminal on Mopar style relays. This wire comes from the start terminal of the ignition switch and through the neutral safety switch on all systems **except Mopar**.
2. The #781 brown wire marked “I term” attaches to the “I” terminal of the Ford and GM style start solenoids and may be used with the Mopar start relay when a diode is included in the circuit (refer to illustration “D”). This wire is used as a resistor bypass only when a Ballast Resistor is installed.
3. The large #716 and #787 red wires attach to the battery cable post of the starter solenoid.

***NOTE:** The 10110 kit includes a “MAXIFUSE” to protect the entire electrical system. Before attaching the large #716 and #787 red wires to the solenoid, mount the maxifuse in a convenient location near the solenoid. Cut the red wires to the correct length and attach to one side of the maxifuse with a terminal provided in the kit. Attach the other side of the maxifuse to the solenoid battery cable post with some of the remaining heavy red wire and terminals provided. This must be used for the overall system protection.*

4. The #783 black wire attaches to the “G” terminal on the Mopar style relay. This wire is not used on Ford or GM style solenoids. .

B. The ignition module group of wires

Motorcraft (Refer to illustration “E”)

1. The #720 red/white wire attaches to the red wire in the 2-way connector of the module.
2. The #719lt.blu wire attaches to the white wire in the 2-way connector of the module.
3. The #782 green wire attaches to the green wire in the 4-way connector of the module.

Prestolite (Refer to illustration “F”)

1. The #782 green wire attaches to the green wire of the control unit.
2. The #720 red/white attaches to the yellow wire of the control unit.

HEI and point style ignition systems (Refer to illustration “G”)

1. The #782 green, #719 lt.blu and #720 red/white wires are not used going to the ignition module. Wires may be cut off or taped and stored.

***NOTE:** On HEI ignition systems, the ballast resistor is not used and the red/white wire referred to on line 5` of step 5 is the only wire used.*

C. The alternator and accessory wires

1. The wires marked “alt” attach as follows; The large #715 and #787 red wires attach to the output post of the alternator and the brown #714 wire attaches to the “I” terminal of the regulator on Motorcraft systems (refer to illustration “I”), to the #1 terminal on internally regulated GM alternators (refer to illustration “J”, to the #3&4 terminals of the GM externally regulated alternator regulator (refer to illustration “K”), to the ign and field terminals on Mopar regulators and alternators (refer to illustration “M”) and to the regulator plug on Motorola systems (refer to illustration “L”).
2. The purple #722 wire marked “oil sender” attaches to the oil pressure sending unit.
3. The purple/white #721 wire marked “temp sender” attaches to the engine temperature sending unit.
4. The gray/white #701 wire marked “engine fan relay” activates the electric fan relay if the vehicle is so equipped.
5. The brown #702 wire marked “a/c comp” powers the air conditioning compressor.

STEP 7

Routing and attaching the front lighting harness

1. Feed the headlight harness through the hole in the radiator support. It may be necessary to remove the “T” connectors on the loom covering to get the wires through the hole and then reinstall them once the wiring is routed. Removing the headlight assemblies will aid in the installation.
2. Run the left marker lamp “EE” through the fender and plug in the light.
3. Plug in the left turn signal/park lamp “DD”.
4. Plug in the left headlight “CC”.
5. Run right light harness assembly under grill shell and attach with clips located behind grill.
6. Run the right marker lamp “HH” harness through the fender and plug in the light.
7. Plug in the right turn signal/park light “GG”.
8. Plug in the right headlight “FF”.

STEP 8

Routing and installing the tail light harness

1. Starting from the rear, feed the wires for plug “U” through the hole in the left rear inner fender well and pull forward until the harness will reach the main harness connector “B” behind the emergency brake. The plug “U” is in with the parts in the bag kit and should be installed onto the wires after they have been routed through the fender well. Plug together plug “U” and “B”.
2. Install the grommet into the hole around the harness after the harness has been positioned along the floor pan.
3. Route the harness in the channel along the base of the wheel well.
4. Plug in the left rear marker light “Y” if so equipped.
5. Attach the pink wire marked “fuel sender” to the fuel tank sending unit with a terminal provided.
6. Terminate black ground wire marked “ground” to a suitable ground.
7. Plug in the left rear tail light connector “X” or install the new connector “Z” that is supplied. Black is ground, white is taillights, white/black is back-up lights and green/black is left turn.
8. Route the right side harness across under the body and secure with the factory clips or wire ties.
9. Plug in the right side marker “W” if so equipped.
10. Plug in the right rear taillight connector “V” or install the new connector “AA” that is supplied. Black is ground, white is taillights, white/black is back-up lights and green is right turn.

STEP 9

Testing the system

1. Attach a small battery charger, 10 amp or less, to the positive and negative battery cables. Cables should still not be attached to the battery.
2. Turn on the charger and check each system for proper operation.
3. If all systems are operating properly, then attach the battery cables to the battery.
4. Congratulations on your installation!

Color	Ga.	No.	Connect to	Origin	Section of Origin
			ACCESSORY SECTION		
Gry/Wht	14	701	Cooling Fan Switch	Electric Fan	Headlight Section A
Brn	14	702	AC/Heat Switch	A/C Compressor	Engine Section A
Red	14	703	Cigarette Lighter B+	Fuse Panel	Fuse Panel
Red	14	704	AC/Heat Switch B+	Fuse Panel	Fuse Panel
Red/Wht	16	705	Wiper Switch B+	Fuse Panel	Fuse Panel
Gry/Wht	18	706	Cooling Fan Switch B+	Fuse Panel	Fuse Panel
Wht/Red	18	759	Clock	Fuse Panel	Fuse Panel
			ALTERNATOR SECTION		
Brn	14	714	Alternator Exciter	Fuse Panel	Fuse Panel
Red	12	715	Alternator B+	Fuse Panel	Fuse Panel
Red	10	787	Alternator B+	Starter relay (B)	Engine Section
			DIMMER SWITCH SECTION		
Red/Wht	14	707	Dimmer Switch	Headlight Switch	Headlight Section B
Gry/Red	14	708	Dimmer Switch	High Beam	Headlight Section A
Gry	14	709	Dimmer Switch	Low Beam	Headlight Section A
			STARTER SOLENIOD SECTION		
Lt.Blu	12	719	Start Solenoid (S) Term	Ign. Switch Start	Ign. Switch Section
Brn	14	781	Start Solenoid (I) Term	Coil (+)	Engine Section A
Blk	16	783	Starter Relay (G) Ground	Backup Switch	Backup Section
Red	10	716	Battery Starter Solenoid B+	Fuse Panel	Fuse Panel
Red	10	787	Starter Relay (B)	Alternator B+	Alternator Section
			EMERGENCY BRAKE SECTION		
Blk	18	762	Emergency Brake Switch	Brake Warn Indicator Light	Instr. Panel Section
Blk	18	760	Brake Pressure Switch (master cylinder)	Emergency Brake Indicator	Instrument Panel Section
			BRAKE SWITCH SECTION		
Rd/Bk	16	717	Brake Switch B+	Fuse Panel	Fuse Panel
Pnk	16	718	Brake Switch	Turn Signal Switch	Turn Signal Section
			ENGINE SECTION A		
Red/Wht	14	720	Coil B+	Fuse Panel	Fuse Panel
Ppl/Wht	18	721	Temperature Sending Unit	Temp. Gauge	Inst. Panel Section
Ppl	18	722	Oil Pressure Sending Unit	Oil Pressure Gauge	Inst. Panel Section
Ppl	18	723	Tachometer Source	Tachometer	Inst. Panel Section
Brn	14	702	A/C Compressor	Fuse Panel	Accy. Section Switches
Red	18	754	Electric Choke	Fuse Panel	Fuse Panel
Grn	16	782	Coil (-)	Ign. Module	Engine Section A
Brn	14	781	Coil (+) Ballast Bypass	Starter Relay	Engine Section A
Tan	14	780	Heater Motor	Heater Switch	Heater Section
Ylw	16	788	Washer Motor	Wiper Switch	Accessory Switch

Table 1.1 Wire Connection Index (1 of 3)

Color	Ga.	No.	Connect to	Origin	Section of Origin
			BACKUP SECTION		
Blk	16	783	Backup Switch	Starter Relay	Starter Solenoid Sect.
Red	18	758	Backup Switch	Fuse Panel	Fuse Panel
Wht/Blk	18	756	Backup Switch	Backup Lights	Tail Section
Org	16	771	Transfer Case	4WD Indicator	Instr. Panel Section
			HEADLIGHT SECTION A		
Rd/Bk	14	724	Horn B+	Horn Relay	Fuse Panel
Grn	18	725	Right Front Turn Signal	Turn Signal Switch	Turn Signal Section
Grn/Blk	18	726	Left Front Turn Signal	Turn Signal Switch	Turn Signal Section
Wht	18	727	Park Lights	Headlight Switch	Headlight Section B
Gry/Red	14	708	High Beam	Dimmer Switch	Dimmer Sw. Section
Gry	14	709	Low Beam	Dimmer Switch	Dimmer Sw. Section
Gry/Wht	18	701	Cooling Fan	Fan Switch	Accy. Section B+
			HEADLIGHT SECTION B		
Red	12	728	Headlight Switch B+	Fuse Panel	Fuse Panel
Red/Wht	14	707	Headlight Switch	Dimmer Switch	Dimmer Sw. Section
Wht	14	729	Headlight Switch	Tail Lights	Tail Section
Wht	18	727	Headlight Switch	Park Lights	Headlight Section A
Orn	18	730	Headlight Switch	Instr. Panel Lighting	Instr. Panel Section
			IGNITION SWITCH SECTION		
Red/Wht	14	731	Ign. Switch (Coil Ign.)	Fuse Panel	Fuse Panel
Ylw	12	733	Ignition Switch (Hot)	Fuse Panel	Fuse Panel
Red	12	734	Ignition Switch B+	Fuse Panel	Fuse Panel
Lt. Blu	12	719	Ignition Switch Start	Starter Solenoid	Engine Section A
Brn	12	790	Ignition Switch (Accessory)	Fuse Panel	Fuse Panel
Blk	12	760	Ignition Switch (Ground)	Fuse Panel	Fuse Panel
			INSTRUMENT PANEL SECTION		
Ylw	18	735	Voltmeter Source and Gauges B+	Fuse Panel	Fuse Panel
Gy/Bk	18	736	High Beam Indicator	Dimmer Switch	Dimmer Sw. Section
Gn/Bk	18	737	Left Turn Indicator	L Front Turn Signal	Turn Signal Section
Grn	18	738	Right Turn Indicator	R Front Turn Signal	Turn Signal Section
Org	18	730	Instr. Panel Lighting	Headlight Switch	Headlight Section B
Pnk	18	739	Fuel Gauge	Fuel Sending Unit	Tail Section
Ppl/Wht	18	721	Temperature Gauge	Temp. Sending Unit	Engine Section A
Ppl	18	722	Oil Pressure Gauge	Oil Pres. Sending Unit	Engine Section A
Ppl	18	723	Tachometer	Tachometer Source	Engine Section A
Blk	18	760	Emergency Brake Indicator	Emer. Brake Switch	Engine Section
Red	18	761	Emer. Brake Indicator B+	Fuse Panel	Fuse Panel
Org	16	771	4WD Indicator	4WD Switch	Engine Section A

Table 1.1 Wire Connection Index (2 of 3)

Color	Ga.	No.	Connect to	Origin	Section of Origin
			TURN SIGNAL SECTION		
Pnk	14	751	Emer. Flasher Switch B+	Emer. Flasher Relay	Fuse Panel
Red/Wht	14	752	Turn Signal Sw.Flasher B+	Turn Flasher Relay	Fuse Panel
Blk/Wht	18	753	Horn Switch	Horn Relay	Fuse Panel
Lt.Grn	14	748	Turn Signal Switch	R Rear Turn Signal	Tail Section
Lt.Gn/Blk	14	749	Turn Signal Switch	L Rear Turn Signal	Tail Section
Grn	18	725	Turn Signal Switch	R Front Turn Signal	Headlight Section A
Pnk	16	718	Turn Signal Switch	Brake Switch	Engine Section A
Grn/Blk	18	726	Turn Signal Switch	L Front Turn Signal	Headlight Section A
			RADIO SECTION		
Blu	18	741	Radio B+ Switched	Fuse Panel	Fuse Panel
			TAIL SECTION		
Blk	14	786	Grounding Point	Tail lights	Tail Section
Lt.Grn	14	748	R Rear Turn Signal	Turn Signal Switch	Turn Signal Section
Lt.Gn/Blk	14	749	L Rear Turn Signal	Turn Signal Switch	Turn Signal Section
Pnk	18	739	Fuel Sending Unit	Fuel Gauge	Instr. Panel Section
Wht	14	729	Tail Lights	Headlight Switch	Headlight Section B
Wht/Blk	18	756	Backup Lights	Backup Switch	Cruise Control Section
			HEATER SECTION		
Red	14	704	Heater Switch B+	Fuse Panel	Fuse Panel
Brn	14	776	Heater Switch	Heater Resistor	Heater section
Brn/Wht	14	778	Heater Switch	Heater Resistor	Heater section
Tan	14	779	Heater Switch	Heater Resistor	Heater section
Tan	14	780	Heater Switch	Heater Motor	Engine Section A
			HEATER RESISTOR SECTION		
Brn	14	776	Heater Resistor	Heater Switch	Heater Section
Brn/Wht	14	778	Heater Resistor	Heater Switch	Heater Section
Tan	14	779	Heater Resistor	Heater Switch	Heater Section
			IGNITION MODULE SECTION		
Grn	16	782	Coil Signal	Coil (-)	Engine Section A
Red/Wht	16	720	Ignition Power	Coil (+)	Engine Section A
LtBlu	16	719	Crank Signal	Starter Solenoid (S) Terminal	Starter Solenoid Section

Table 1.1 Wire Connection Index (3 of 3)

ILLUSTRATION "A"

WIRE COLOR TO CONNECTOR GLOSSARY:

- Ⓐ 3-WAY CONN: RD/VT, GRN, GY/RD
- Ⓑ 6-WAY CONN: PK, LTGN, LTGN/BK, VT, VT/BK
- Ⓒ 2-WAY CONN: DR, BK
- Ⓓ 7-WAY CONN: DR, BK, VT, RD, RD, RD/VT
- Ⓔ 5-WAY CONN: RD, TN, TN, BN, BN/VT
- Ⓕ 2-WAY CONN: PK, RD/BK
- Ⓖ 11-WAY CONN: BK/VT, PK, RD/VT, PK, LTGN/BK, LTGN, GN/BK, GN/BK, GRN, GRN, DRN
- Ⓗ 5-WAY CONN: YL, RD/VT, RD, LTBL
- Ⓘ 4-WAY CONN: BK
- Ⓛ 3-WAY CONN: TN, BN, BN/VT
- Ⓚ 3-WAY CONN: GN/BK, BK
- Ⓛ 3-WAY CONN: GN/BK, BK
- Ⓜ 3-WAY CONN: GY/BK, BK
- Ⓝ 3-WAY CONN: RD, BK
- Ⓟ 3-WAY CONN: RD, DR
- Ⓠ 1-WAY CONN: RD/VT
- Ⓡ 1-WAY CONN: DR, BK
- Ⓢ 1-WAY CONN: DR, DR
- Ⓣ 1-WAY CONN: DR, BK
- Ⓤ 1-WAY CONN: YL
- Ⓧ NOTHING ON END OF WIRE

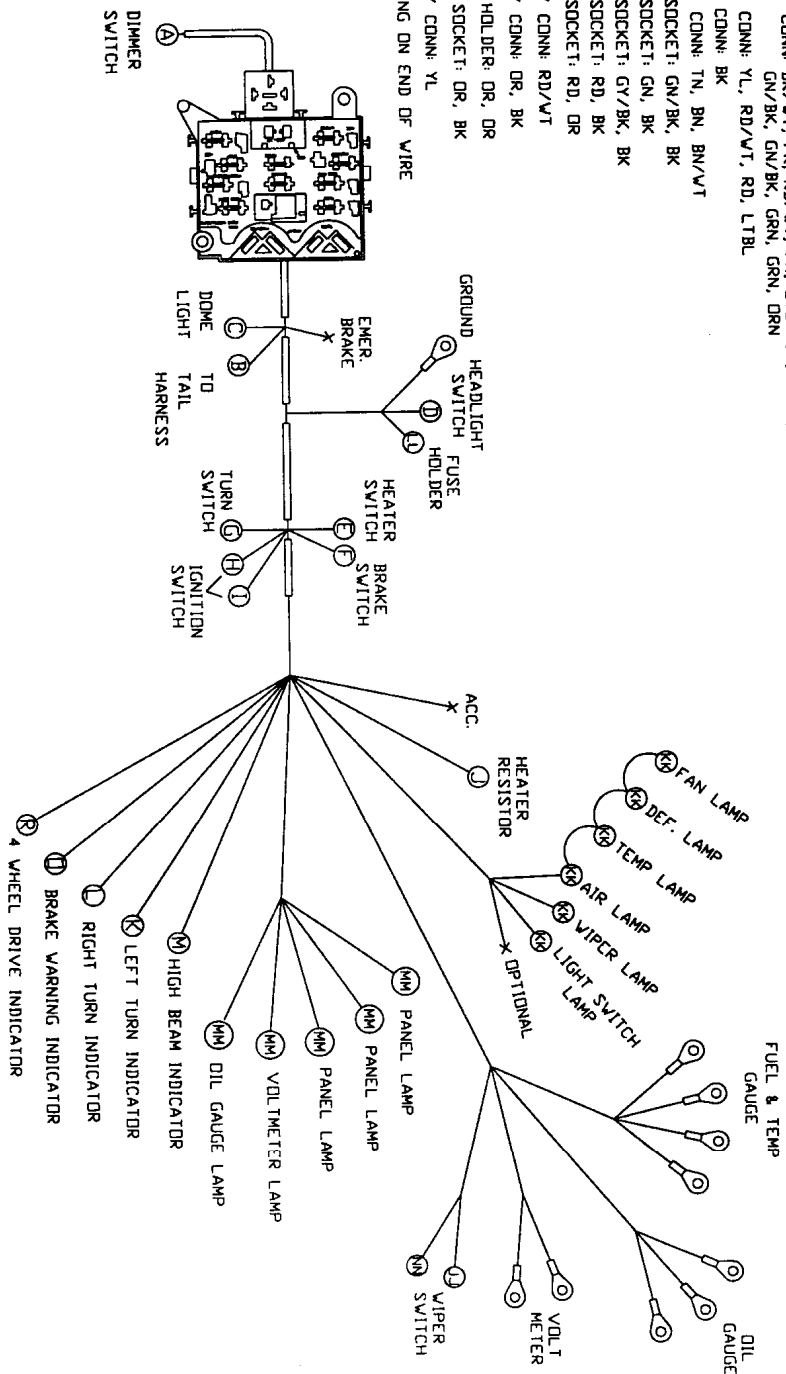

WIRE COLOR TO CONNECTOR GLOSSARY:

- BB 2-WAY CONN: BK, BK
- CC HEADLIGHT CONN: GY/RD, GY, BK
- DD 2-WAY CONN: GN/BK, VT
- EE LAMP SOCKET: BK, VT
- FF HEADLIGHT CONN: GY/RD, GY, BK
- GG 2-WAY CONN: GN, VT
- HH LAMP SOCKET: BK, VT
- II 1-WAY CONN: TN
- DD 1-WAY CONN: RD/BK
- DD 1-WAY CONN: YL
- X NOTHING ON END OF WIRE

ILLUSTRATION "B"

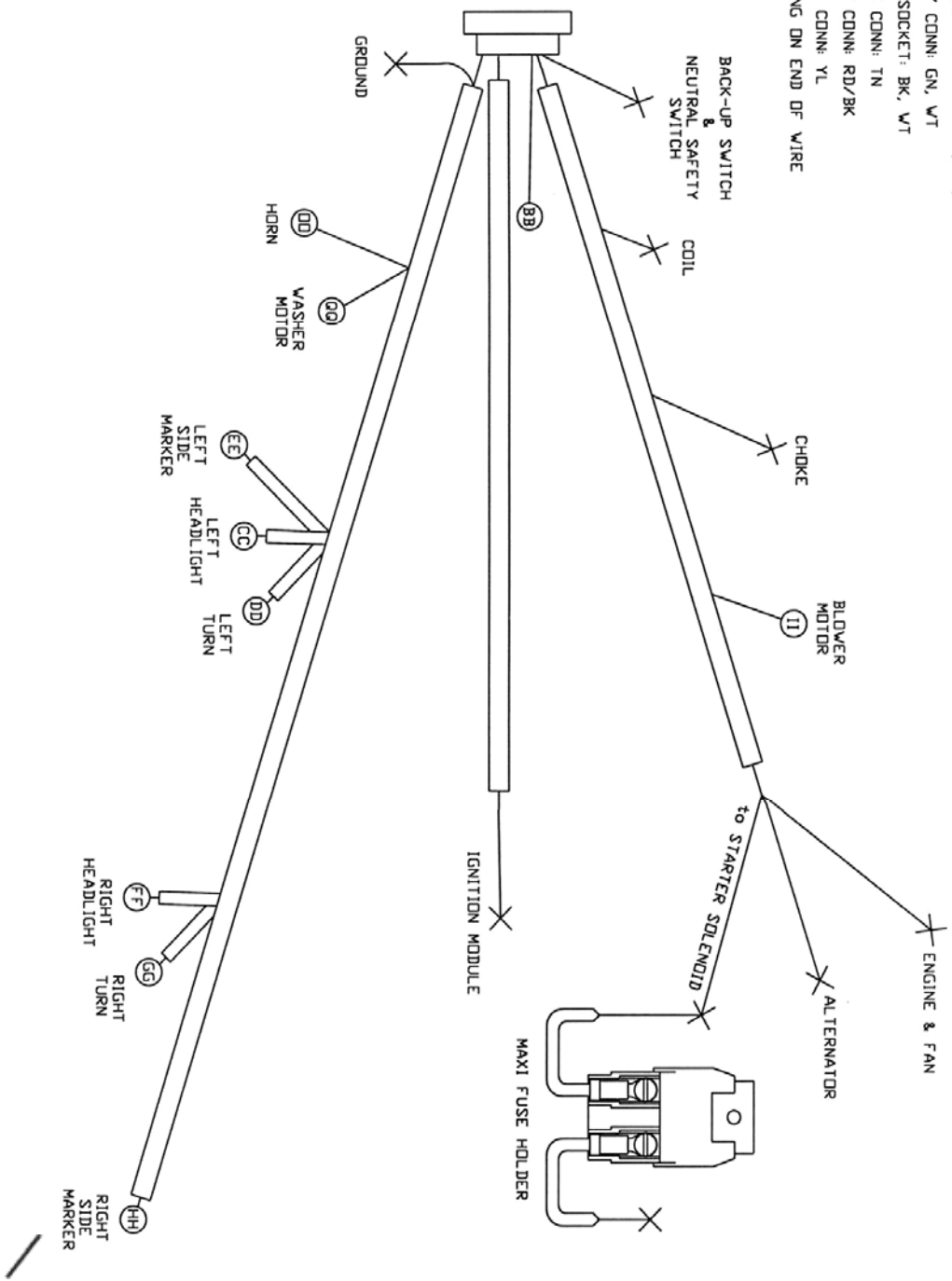
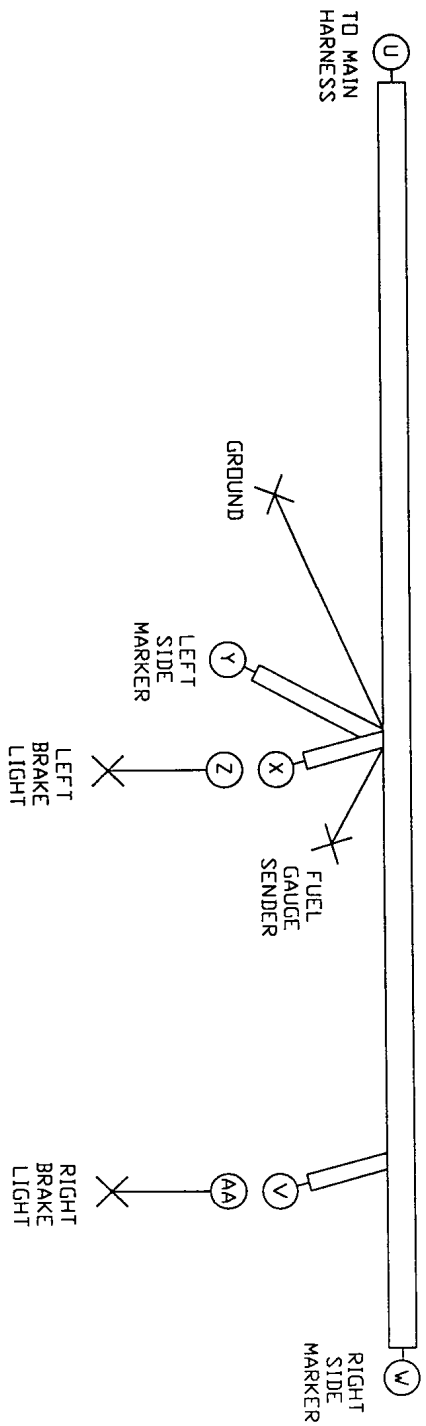

ILLUSTRATION "C"

WIRE COLOR TO CONNECTOR GLOSSARY:

- U 6-WAY CONN: PK, WT/BK, LTGN, LTGN/BK, WT (This connector is in the bag kit and is installed by the customer.)
- V 4-WAY CONN: WT, LTGN, WT/BK, BK
- W LAMP SOCKET: BK, WT
- X 4-WAY CONN: WT, LTGN/BK, WT/BK, BK
- Y LAMP SOCKET: BK, WT
- Z 4-WAY CONN: WT, LTGN/BK, WT/BK, BK
- AA 4-WAY CONN: WT, LTGN, WT/BK, BK
- X NOTHING ON END OF WIRE



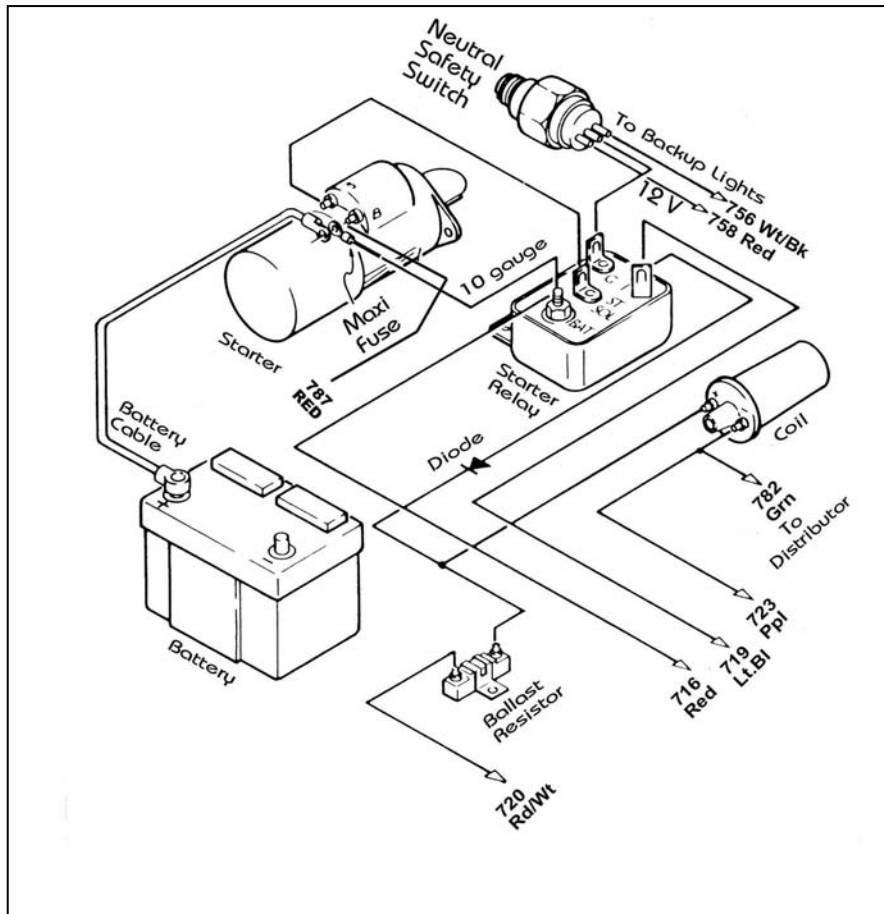

Illustration D Mopar Ignition (Start/Run) System

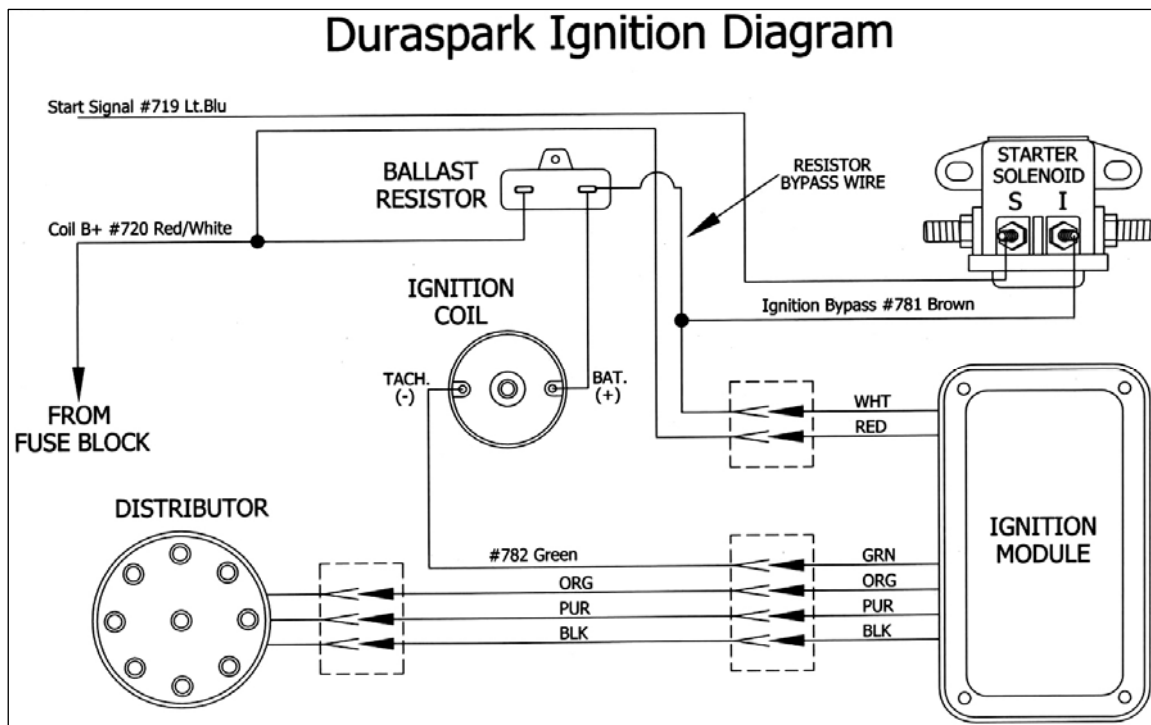

Illustration E Duraspark Electronic Ignition (Start/Run) System

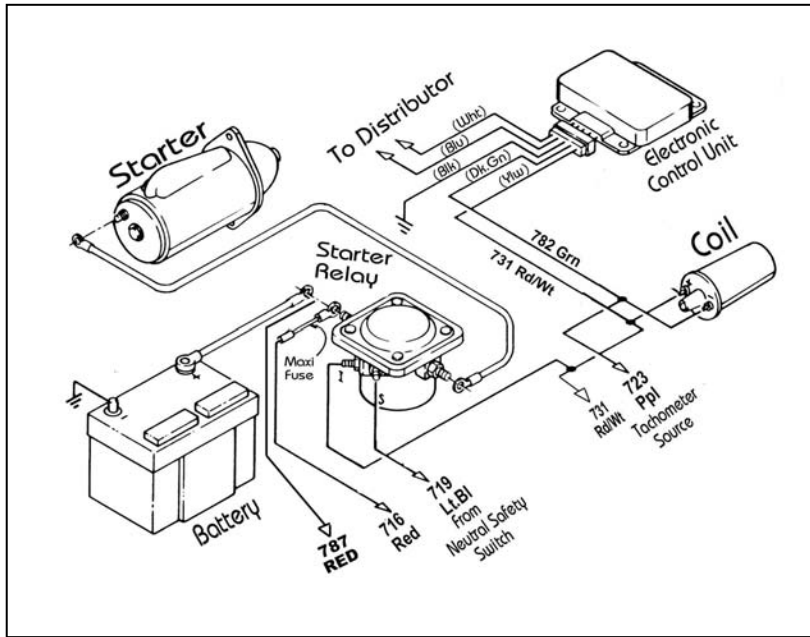

Illustration F Prestolite BID Ignition (Start/Run) System

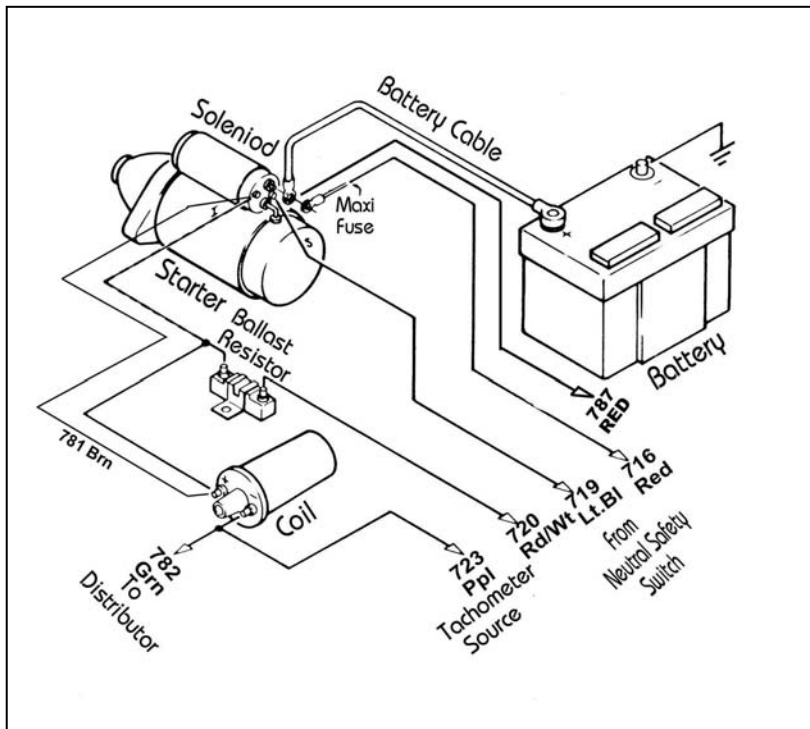

Illustration G Delco Ignition (Start/Run) System

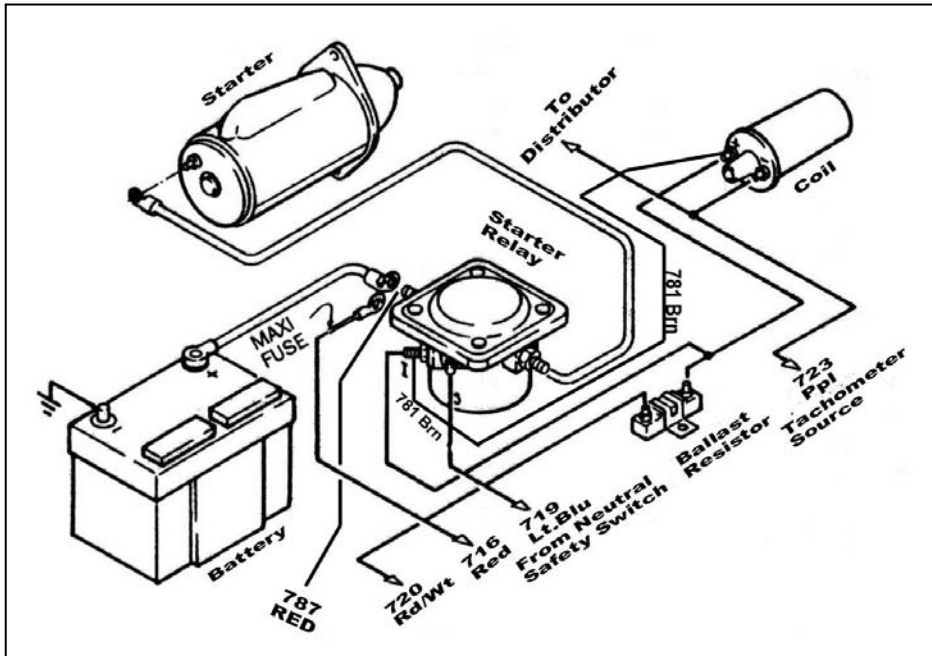

Illustration H Ford Ignition (Start/Run) System

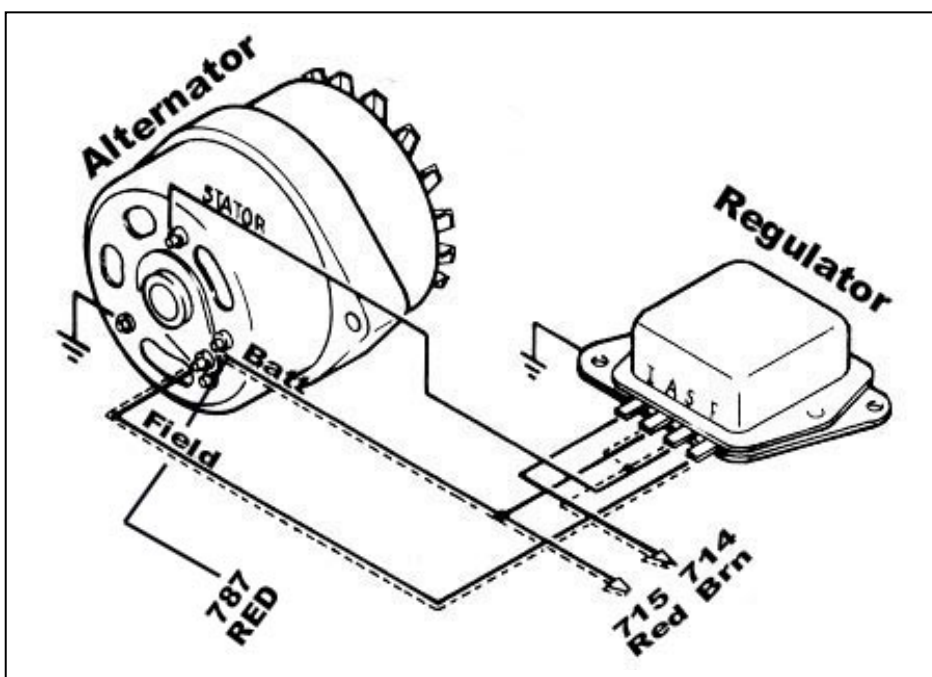

Illustration I Motorcraft Alternator

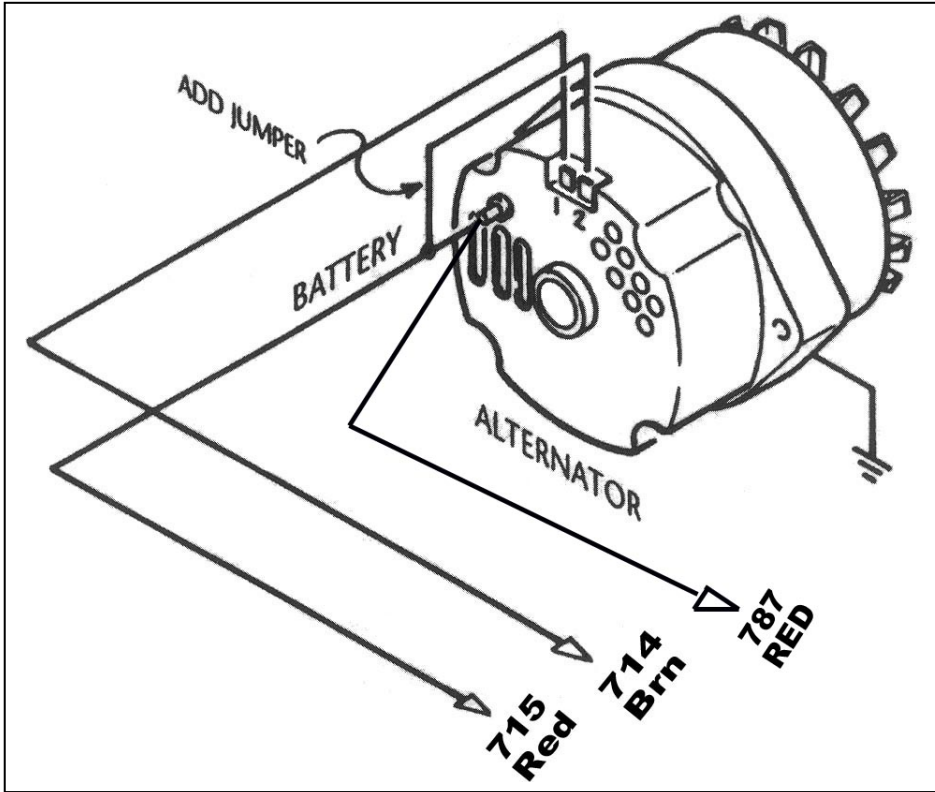

Illustration J Delco Alternator (Internal)

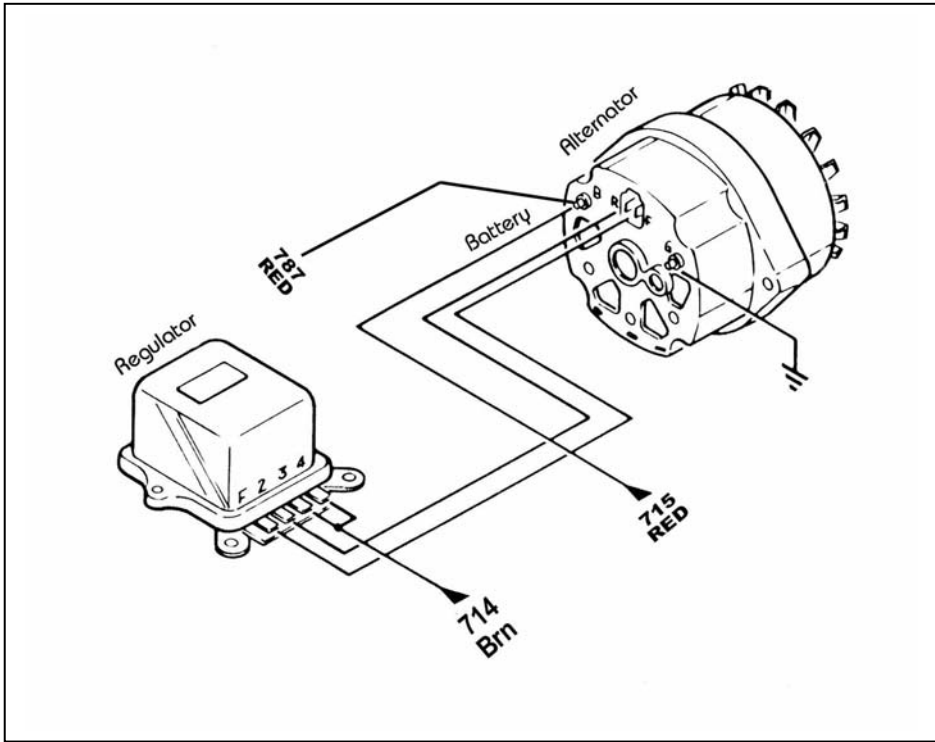

Illustration K Delco Alternator (External)

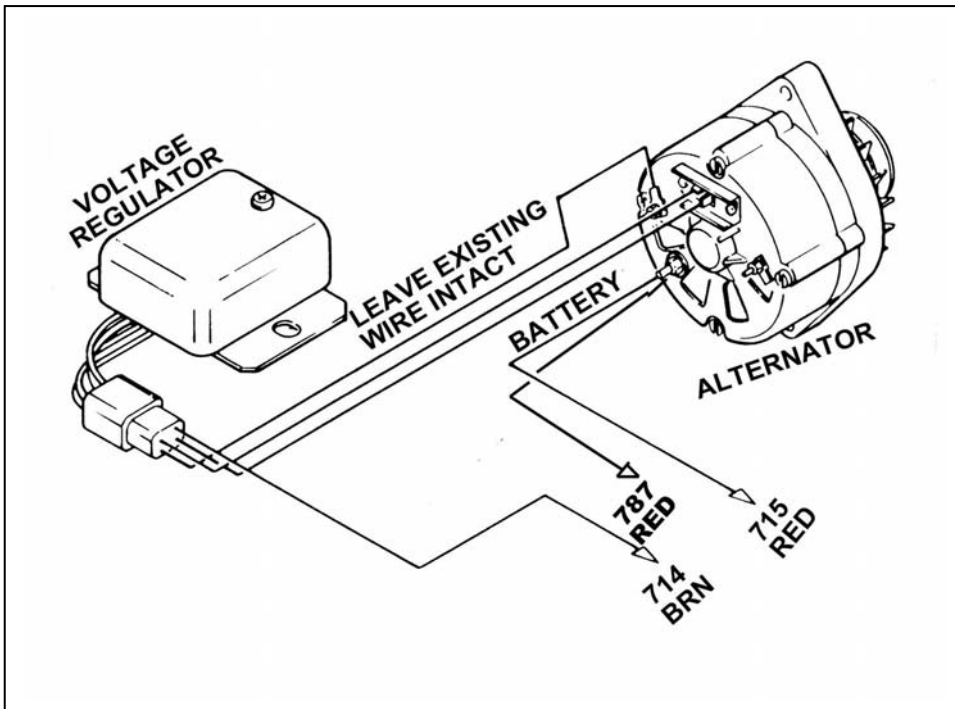

Illustration L Motorola Charging System

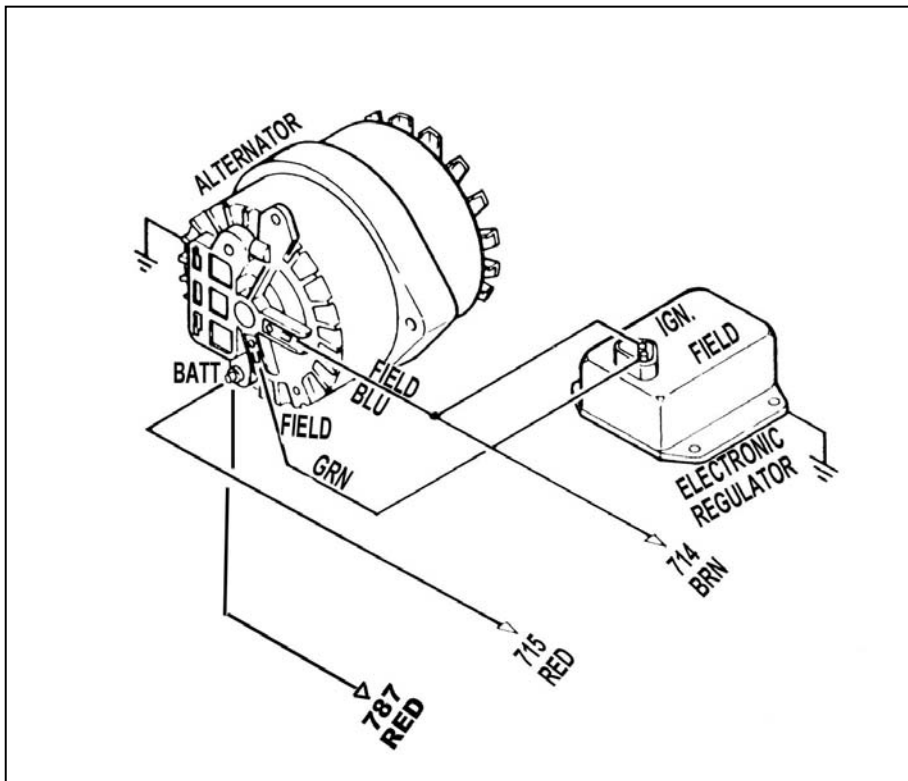
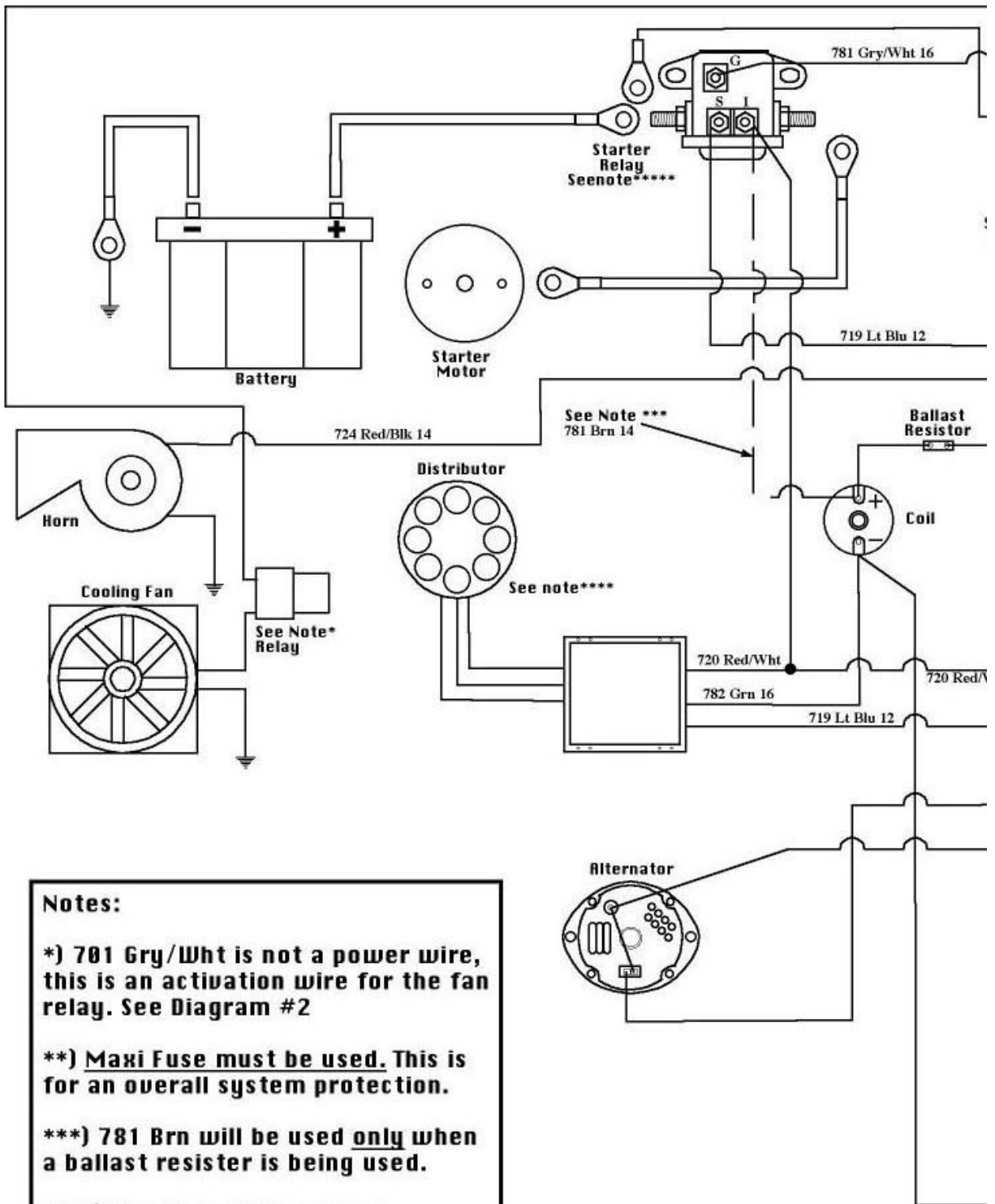

Illustration M Mopar Alternator



Notes:

***) 701 Gry/Wht is not a power wire, this is an activation wire for the fan relay. See Diagram #2**

*****) Maxi Fuse must be used. This is for an overall system protection.**

*****) 781 Brn will be used only when a ballast resistor is being used.**

******) Use the existing wires**

*******) Ground terminal is only for the Mopar starter relay.**

Diagram #1

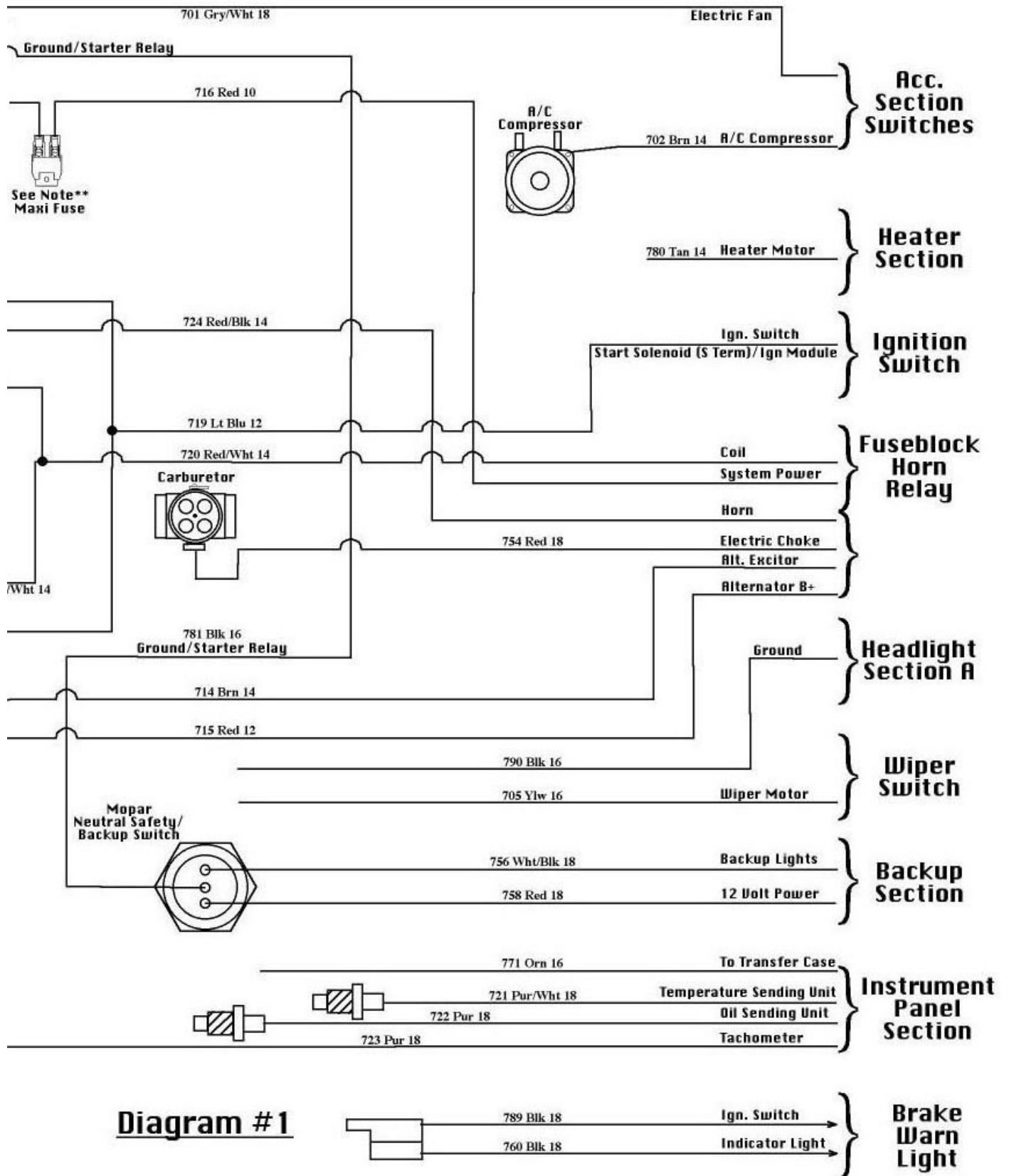

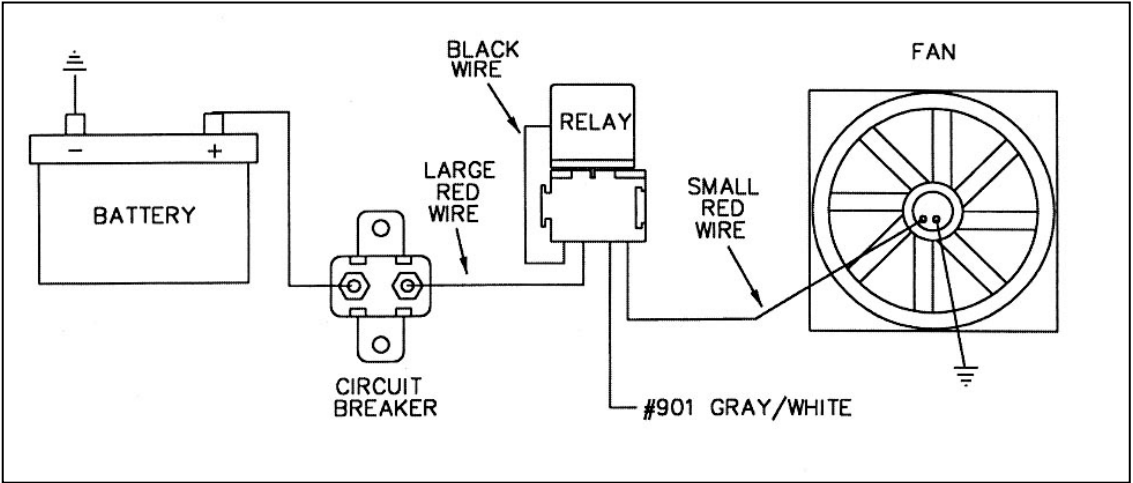
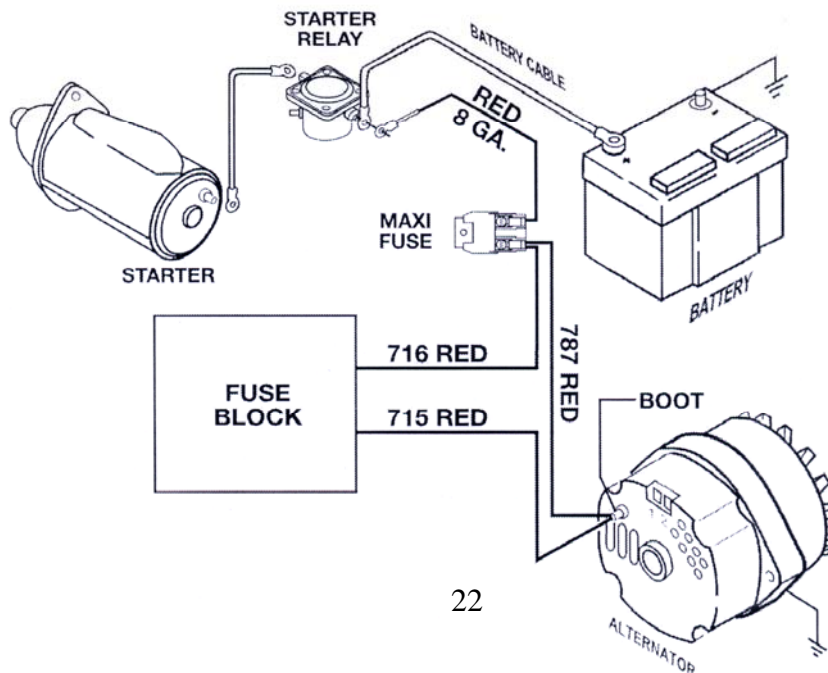
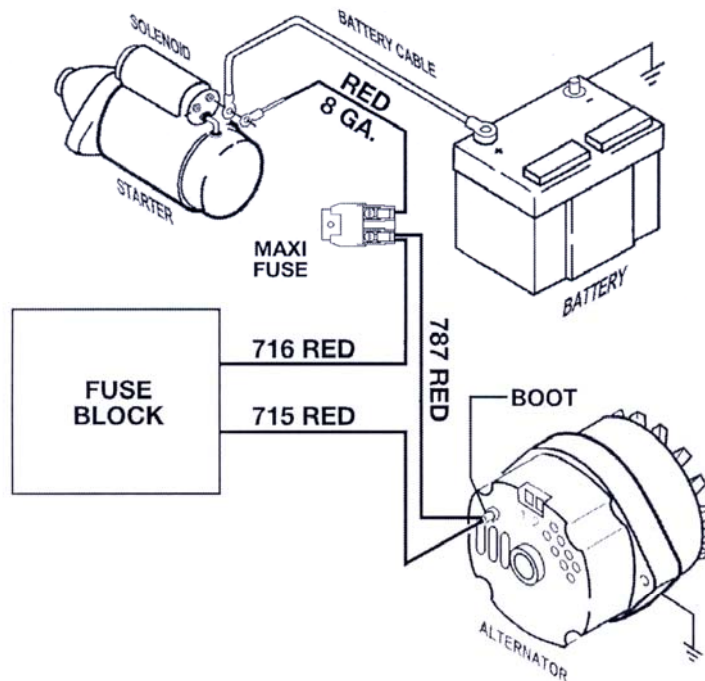

Diagram 2 Electric Fan Relay (Relay Kit – Painless Part #30101)



90513 Installation Manual Supplement

The 787 RED wire that goes from the alternator to the starter relay or solenoid must be connected to the fuse block side on the maxi fuse instead of directly connecting it to the relay or solenoid. The 2-foot of 8 gauge RED wire that came in the box is to be connected to the starter relay or solenoid and routed to the maxi fuse as shown below. **CAUTION: If this connection is not made as stated above and shown in the illustrations below, the maxi fuse will not properly protect the electrical system.**



Perfect Performance Products, LLC shall in no event be liable in contract or tort (including negligence) for special, indirect, incidental, or consequential damages, such as but not limited to, loss of property damage, or any other damages, costs or expenses which might be claimed as the result of the use or failure of the goods sold hereby, except only the cost of repair or replacement.

P/N 90513 Painless Wiring Manual

April 2005

Copyright © 1996 by Perfect Performance Products, LLC

Painless Performance Limited Warranty and Return Policy

Chassis harnesses, fuel injection harnesses, and Striker ColdShot units are covered under a lifetime warranty.

All other products manufactured and/or sold by Painless Performance are warranted to the original purchaser to be free from defects in material and workmanship under normal use. Painless Performance will repair or replace defective products without charge during the first 12 months from the purchase date. No products will be considered for warranty without a copy of the purchase receipt showing the sellers name, address and date of purchase. You must return the product to the dealer you purchased it from to initiate warranty procedures.