





Installation Instructions Headliner



For Original Equipment Soft Top and Bestop Supertop

Vehicle Application

- Jeep TJ Wrangler
1997 – 2006
Part Number: 51818

www.Bestop.com - We're here to help! Visit our web site and click on ["Ask a Question"](#). Click here for more [Jeep Accessories by Bestop](#).

INSTALLATION TIME	SKILL LEVEL
 <p>1 Hour</p>	 <p>2 - Moderately Easy</p>

TOOLS	
 <p>Scissors</p>	 <p>Safety Glasses</p>



 **CAUTION** Safety glasses should be worn at all times while installing this product.

Installation Tips
 Before you begin installing this assembly, read all instructions thoroughly.

For a smooth fit:
 For ease in installation, the product should be installed at temperatures above 72° F. Below this temperature, the fabric may contract an inch or more, making it difficult to fit to the vehicle. It is normal for fabric to contract and wrinkle when stored in the shipping carton. Within a few days after the installation, the fabric will relax and the wrinkles will disappear.

 **WARNING** This product is designed primarily to enhance the appearance of the vehicle and to shield the occupants from ordinary weather conditions. Do not rely in any way on the components of this product to contain occupants within the vehicle, or to protect against injury or death in the event of an accident. This product will not protect the occupants from falling objects. Never operate the vehicle in excess of manufacturer's specifications.

WEAR SEAT BELTS AT ALL TIMES

Read and follow, precisely, all installation instructions provided when installing product. Failure to do so may result in a poor fit and could place occupants of the vehicle in a potentially dangerous situation.

Headliner – Installation Instructions

Parts List

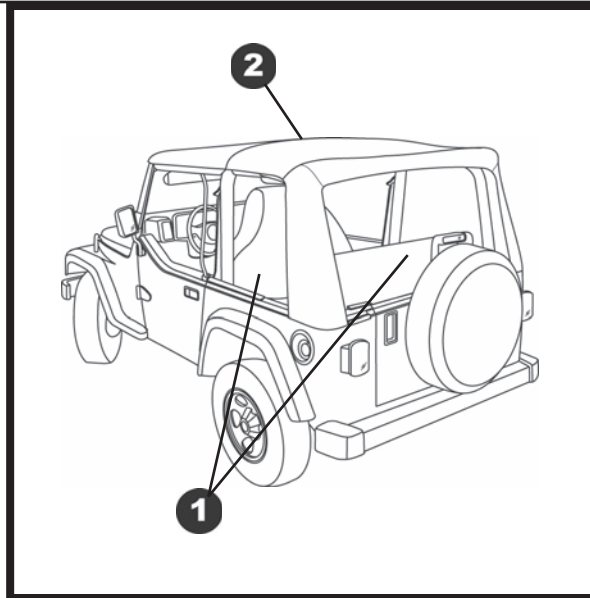
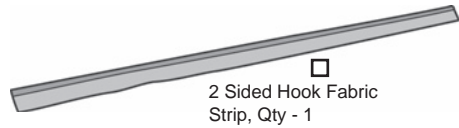
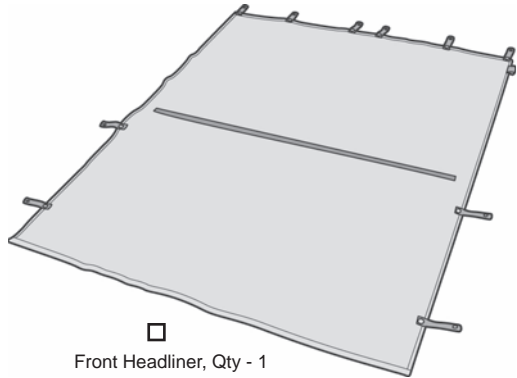

1 Remove Rear and Side Windows

Remove the Rear and Side Windows on the Top.

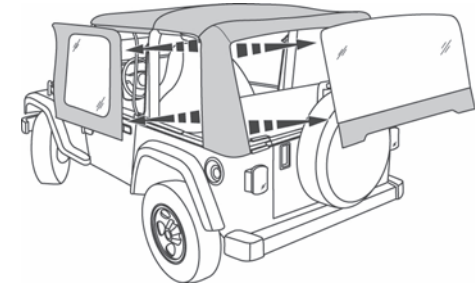

2 Release Top from Center Bow

Release the hook and loop flap around the Center Bow.

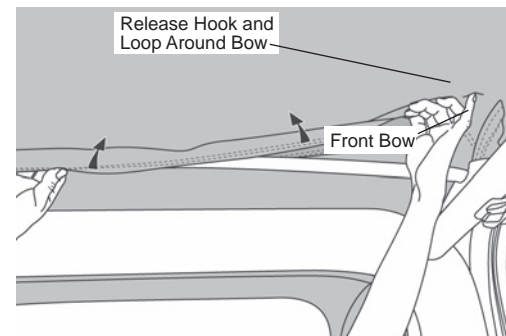

Headliner – Installation Instructions

3 Expose Top of Header

Fold the top fabric forward to expose the top of the header.

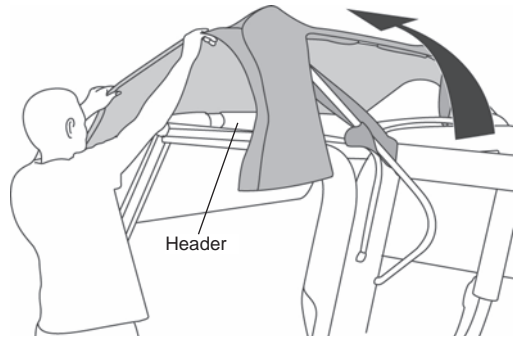

4 Install Adhesive Hook on Header

Cut three (3) pieces of Adhesive Hook Strip to fit along the Header. Peel the backing off the Adhesive Hook Strip and press it firmly into place on the Header as shown. Repeat on both sides of the vehicle.

NOTE Allow 72 hours for the adhesive to set. Avoid unnecessary fastening and unfastening of the Headliner during this period.

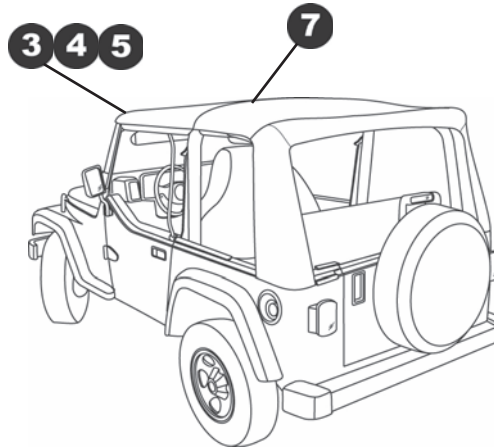
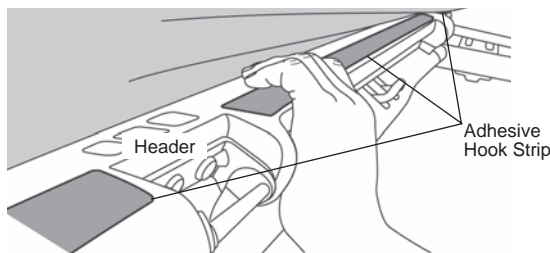

6 Lower Soft Top

Lower the soft top.

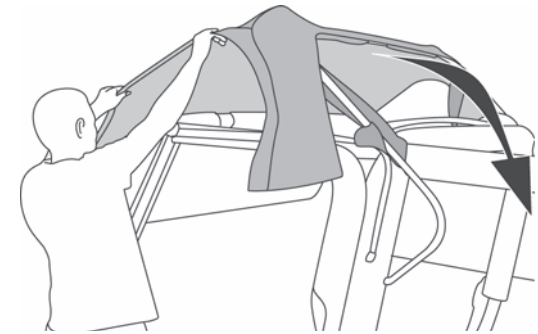

5 Secure Headliner to Header

Center the Front Headliner on the vehicle. Fasten the loop strip sewn to the front of the Front Headliner to the Adhesive Hook Strip installed on the Header.

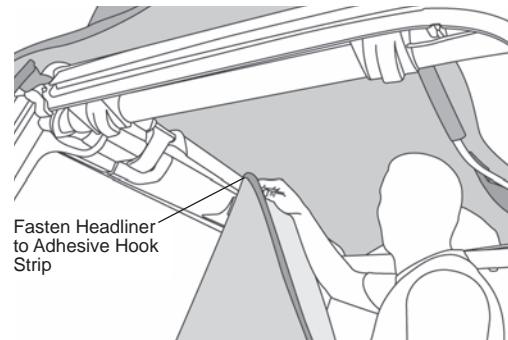

7 Install 2 Sided Hook Strip

Fasten the 2 Sided Hook Strip to the loop on the flap around the Center Bow. Make sure that the hook side faces out.

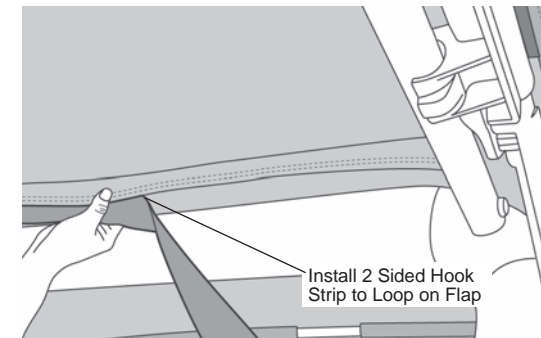

Headliner – Installation Instructions

8 Secure Hook Flap around Center Bow

Close the flap and the 2 Sided Hook Strip around the Center Bow.

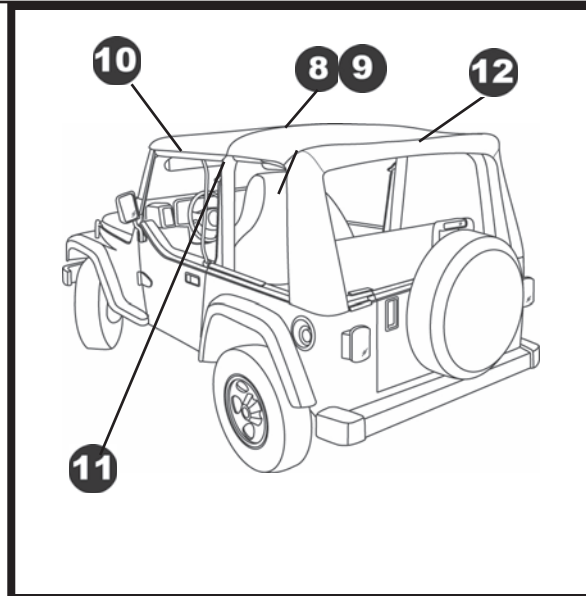
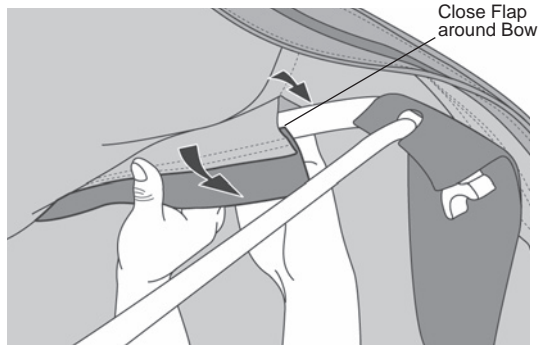

11 Secure Rear Straps

Wrap the rear strap on the headliner around the upper arm of the Side Bow and snap together. Repeat for other side.

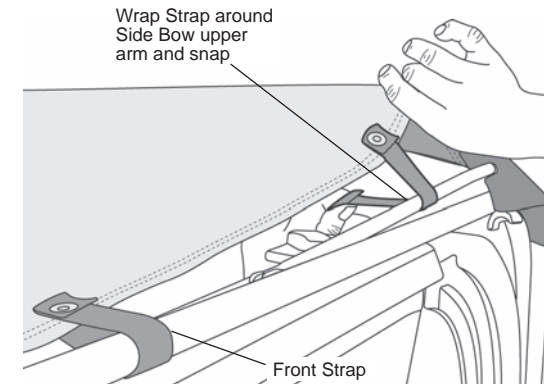

9 Slip Headliner over Sound Bar

Slip the Headliner Fabric between the Sound Bar and the Top Fabric.

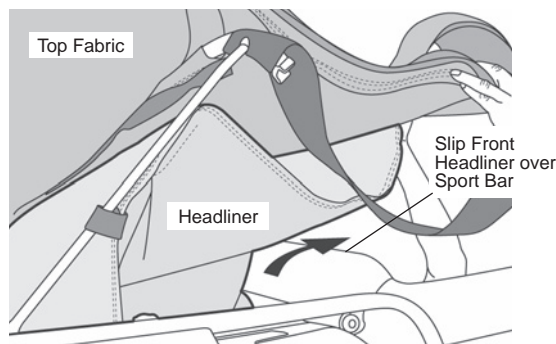

10 Secure Headliner Straps

Wrap the front strap on the Headliner around the Side Bow and snap it to itself. Repeat on both sides.

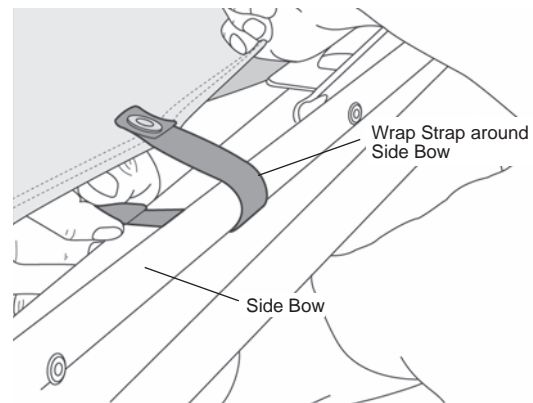

12 Release Top from Rear Bow

Unsnap the two (2) rear flaps on the top from the Rear Bow.

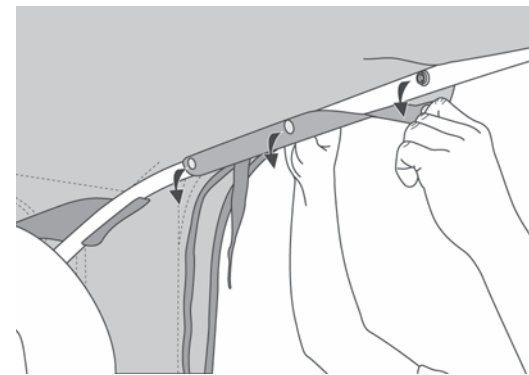

Headliner – Installation Instructions

13 Secure Headliner to Rear Bow

Wrap the rear straps on the Headliner around the Rear Bow and snap together.

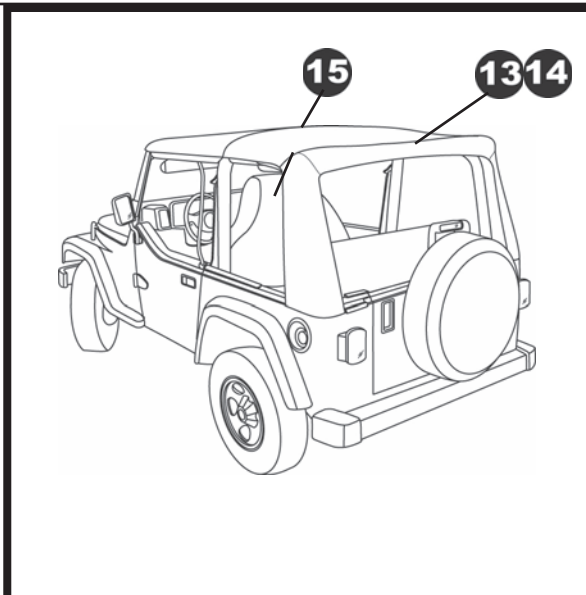
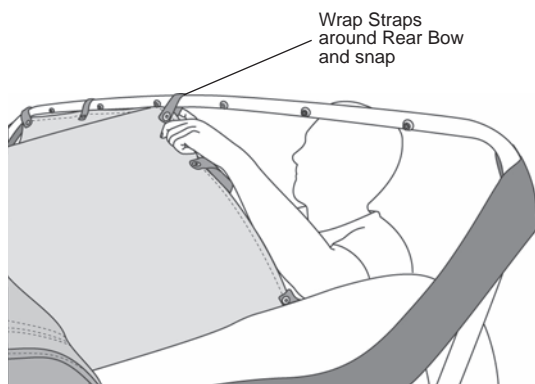

14 Secure Top Fabric to Rear Bow

Snap the rear flaps on the soft top around the Rear Bow.

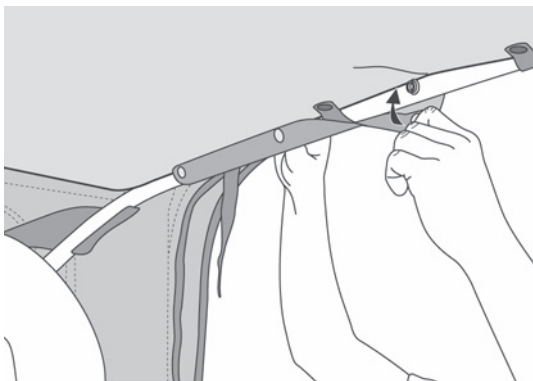

15 Secure Front Headliner to Center Bow

Press up on the Front Headliner to secure it to the Adhesive Hook Strip installed on the Center Bow in Step 7.

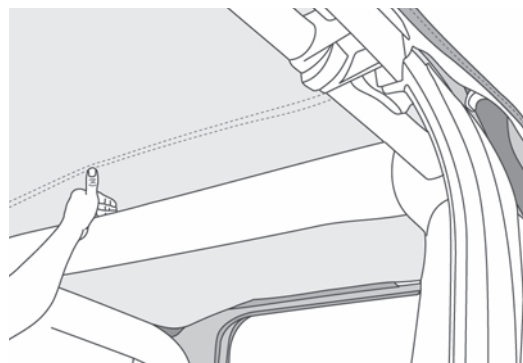

Headliner – Installation Instructions

Care and Maintenance of your Bestop Product

Your Bestop product is made of the finest materials available. To keep it looking new and for the maximum possible wear, it will need periodic cleaning and maintenance.

Washing: The fabric should be washed often using soap, warm water and a soft bristle brush. Rinse with clear water to remove all traces of soap or use Bestop-recommended Bestop Cleaner and Bestop Protectant. Bestop Cleaner and Bestop Protectant are specially formulated to provide a total cleaning and protection system. Bestop Cleaner will not harm vehicle finish, is biodegradable and environmentally friendly. Bestop Protectant protects against UV-fading, cracking and hardening.

Windows: Keep windows clean to avoid scratching. DO NOT use a brush on the windows! Wash with a water-soaked cloth or sponge and a mild dishwashing detergent or use Bestop-recommended Bestop Vinyl Window Cleaner, which safely cleans and protects vinyl windows while helping prevent UV damage. NEVER WIPE THE WINDOWS WHEN THEY ARE DRY. Be careful when cleaning snow or frost from the vinyl windows since they are easily scratched and may crack at low temperatures. DO NOT roll the sides or rear window in cold weather. The windows become stiff and will crack.

Zippers: Keeping the zipper cleaned and lubricated with a silicone lubricant will help prevent damage and keep the zippers in a smooth working condition. If a zipper opens behind the slider, the slider may have been spread apart. This problem can usually be repaired by using an ordinary pair of pliers to bring the sides back into parallel. Return slider to the end of the zipper in the normal Open position. Squeeze lightly at first and test the zipper. If the zipper continues to remain open squeeze more firmly with the pliers and try the zipper again. Repeat this procedure until the zipper operates correctly.

Water: Seeping through at the seams may be stopped by applying 3-M Scotchgard® on the inside of the seams. Rips in the fabric may be repaired with Bondex® iron on patches. Iron the patches to the Inside of the top, carefully following the Bondex® instructions.

Snaps: Keep snaps cleaned and lubricated with silicone to help prevent snaps from sticking to the studs. If a snap does become stuck to a stud, use a screwdriver and GENTLY pry apart to prevent permanent damage to the snap or the top fabric.

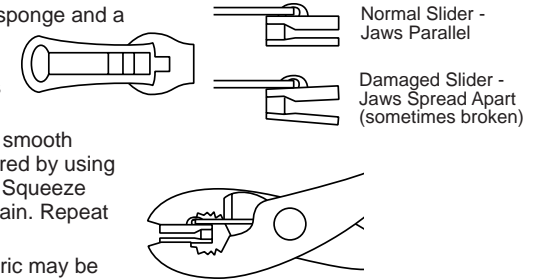

LIMITED WARRANTY

We warrant our product to be free from defects in material and workmanship, for the terms specified below, provided there has been normal use and proper maintenance. This warranty applies to the original purchaser only. All remedies under this warranty are limited to the repair or replacement of any item or items found by the factory to be defective within the time period specified. If you have a warranty claim, first you must call our factory at the number below for instructions. You must retain proof of purchase and submit a copy with any items returned for warranty work. Upon completion of warranty work, if any, we will return the repaired or replaced item or items to you freight prepaid. Damage to our products caused by accidents, fire, vandalism, negligence, misinstallation, misuse, Acts of God, or by defective parts not manufactured by us, is not covered under this warranty.

THE WARRANTY TIME PERIOD IS AS FOLLOWS FOR REPLACE-A-TOP™, SAILCLOTH REPLACE-A-TOP™, SUPERTOP®, SUPERTOP® REPLACEMENT SKINS, SUNRIDER®, AND TIGERTOP®: TWO YEARS FROM DATE OF PURCHASE.

THE WARRANTY TIME PERIOD IS AS FOLLOWS FOR ALL OTHER "SOFT GOODS" MANUFACTURED BY OUR COMPANY (USING PRIMARILY VINYL, PLASTICS, AND/OR FOAM): ONE YEAR FROM DATE OF PURCHASE.

THE WARRANTY TIME PERIOD IS AS FOLLOWS FOR ALL OTHER "HARD GOODS" MANUFACTURED BY OUR COMPANY (USING PRIMARILY METALS, PLASTICS, AND/OR FIBERGLASS): ONE YEAR FROM DATE OF PURCHASE.

ANY IMPLIED WARRANTIES OF MERCHANTABILITY AND/OR FITNESS FOR A PARTICULAR PURPOSE CREATED HEREBY ARE LIMITED IN DURATION TO THE SAME DURATION AND SCOPE AS THE EXPRESS WRITTEN WARRANTY. OUR COMPANY SHALL NOT BE LIABLE FOR ANY INCIDENTAL OR CONSEQUENTIAL DAMAGE.

Some states do not allow limitations on how long an implied warranty lasts, or the exclusion or limitation of incidental or consequential damages, so the above limitations or exclusions may not apply to you. This warranty gives you specific legal rights, and you may also have other rights which vary from state to state.



For further information or request for warranty work, please contact:

Bestop Inc., Customer Service
Toll-Free: (800) 845-3567
Main: (303) 465-1755
E-mail: csbestop@Bestop.com
Website: www.Bestop.com