



**BESTOP**  
/inc.

www.bestop.com

## Supertop with Tinted Sides and Rear Curtain Installation Instructions

For: 1980 - 1986 CJ7 and

1988 - 1995 Wrangler with Steel Half Doors

Part Number: 54600

**Special Note:** This door may be installed on 1986 - 1987 vehicles.  
However, the door retainer in Step Nineteen must first be purchased from your dealer.  
The door in this kit is not compatible with factory installed soft tops.

**DO NOT INSTALL THIS PRODUCT ON ANY  
VEHICLE OTHER THAN THOSE LISTED ABOVE.**

*This product is only designed for the vehicles listed above. Failure to install this product on the proper vehicle could cause injury to the vehicle occupants and damage to the product.*

### WARNING

This Supertop is designed primarily to enhance the appearance of the vehicle and to shield the occupants from ordinary weather conditions. Do not rely in any way on the components of this product to contain occupants within the vehicle, or to protect against injury or death in the event of an accident. This Supertop will not protect the occupants from falling objects. Never operate vehicle in excess of manufacturer's specifications.

WEAR SEAT BELTS AT ALL TIMES

Read and follow, precisely, all installation instructions provided when installing top. Failure to do so may result in a poor fitting top and could place occupants of the vehicle in a potentially dangerous situation.

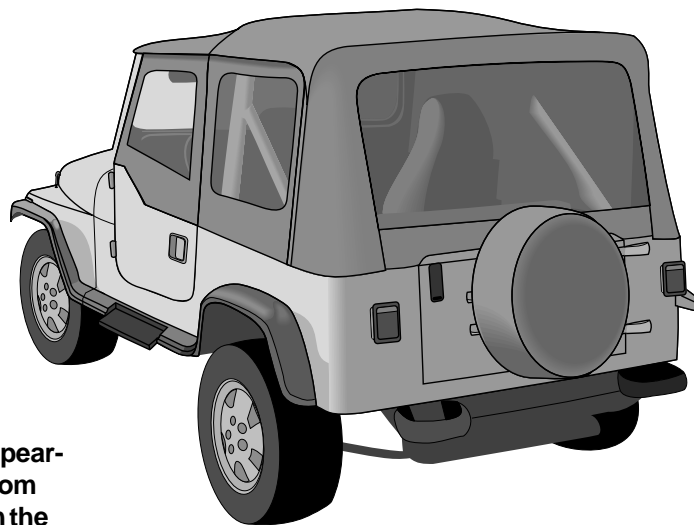

### Installation Tips

*Before you begin installing this Supertop assembly, read all instructions thoroughly. Below are a few tips to make this installation easier.*

#### For a smooth fit:

For ease in installation, the Supertop should be installed at temperatures above 72° F. Below this temperature, the top may contract an inch or more, making it difficult to fit to the vehicle.

It is normal for a top to contract and wrinkle when stored in the shipping carton. Within a few days after the installation, the top will relax and the wrinkles will disappear.

# Parts List and Hardware Identification

Top Fabric	Qty - 1
Quarter Window, Right	Qty - 1
Quarter Window, Left	Qty - 1
Rear Window	Qty - 1
Door, Upper - Right	Qty - 1
Door, Upper - Left	Qty - 1

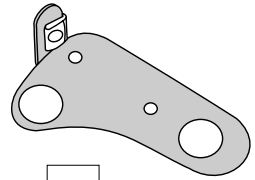

Windshield Bracket - Left, Qty - 1, Part Number 137.97

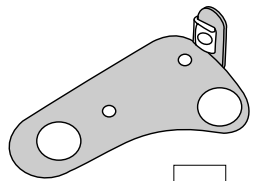

Windshield Bracket - Right, Qty - 1, Part Number 137.96

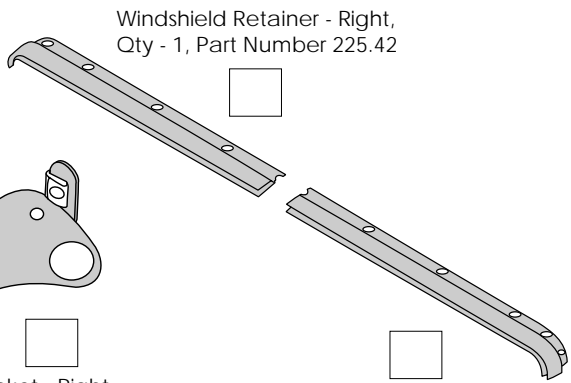

Windshield Retainer - Right, Qty - 1, Part Number 225.42

Windshield Retainer - Left, Qty - 1, Part Number 225.43

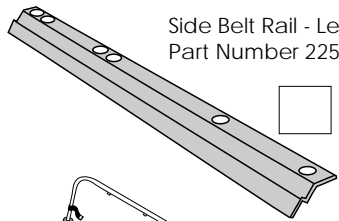

Side Belt Rail - Left, Qty - 1, Part Number 225.05

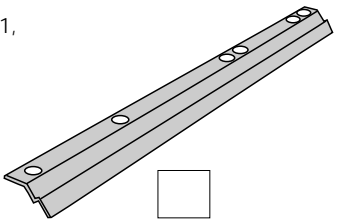

Side Belt Rail - Right, Qty - 1, Part Number 225.04

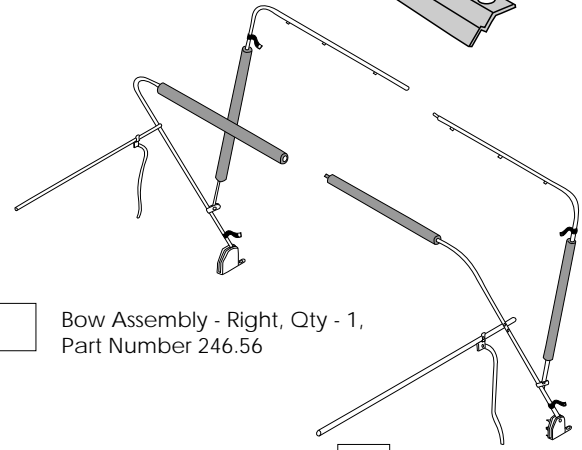

Bow Assembly - Right, Qty - 1, Part Number 246.56

Bow Assembly - Left, Qty - 1, Part Number 246.57

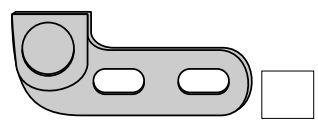

Vertical Retainer Mount, Right, Qty - 1, Part Number 229.24

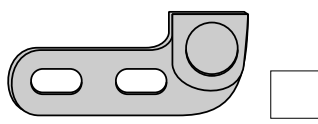

Vertical Retainer Mount, Left, Qty - 1, Part Number 229.25

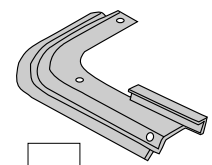

Corner Belt Rail, Left, Qty - 1, Part Number 288.34

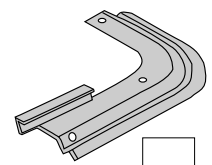

Corner Belt Rail, Right, Qty - 1, Part Number 288.33

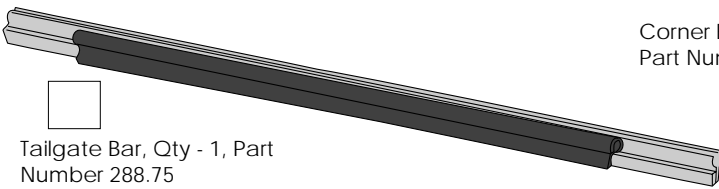

Tailgate Bar, Qty - 1, Part Number 288.75

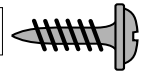
#8 x 1/2" Pan Head Washer Screw - Black, Qty - 13, Part Number 200.48 

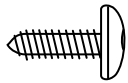
#10 x 1/2" Pan Head Sheet Metal Screw, Qty - 4, Part Number 1.92 

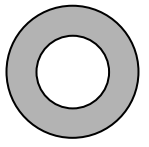
5/16" Black Washer, Qty - 16, Part Number 233.04 

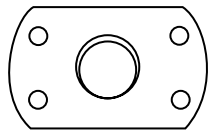
5/16-18 Tapping Plate, Qty - 16, Part Number 200.50 

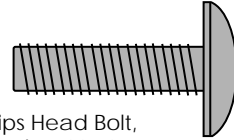
5/16-18 x 1" Phillips Head Bolt, Qty - 16, Part Number 236.20 



## CJ7 Only - Wrangler Adjustment on next page

### Please note

If you are replacing an old soft top, be certain that all parts of the old top are removed, including the windshield retainer. Old metal parts are not compatible with the new Supertop. Using parts other than those provided in your Supertop kit can result in personal injury and/or damage to the vehicle and soft top.

### Windshield Measurement

Before installing the top, check the windshield measurement. The distance from the top lip of the windshield to the top outer edge of the body must be **75 1/8"** on both sides of the vehicle. Measure 4"-6" inside the doors.

### CJ7 Windshield Adjustment

If necessary, loosen the two screws in the Windshield Clamps at the base of the windshield on each side of the vehicle. Adjust the windshield forward or back, use a shim if needed to position the windshield, and tighten the screws.

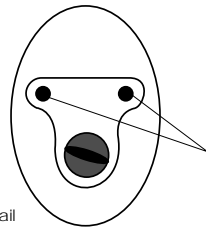

Adjusting Screws - Some Models may require a #40 Torx

Windshield Clamp Detail

### Step One

**CJ7:** After adjusting the windshield, install the Windshield Brackets. If present remove the outboard sun visor fasteners on both sides of the windshield frame. Place the Windshield Brackets flush with the frame on the upper corners of the windshield. Use the bracket as a template to mark, center punch and drill two 5/32" holes for each bracket. Mount each bracket to the windshield frame using two #10 x 1/2" Pan Head Sheet Metal Screws. Reinstall sun visor brackets.

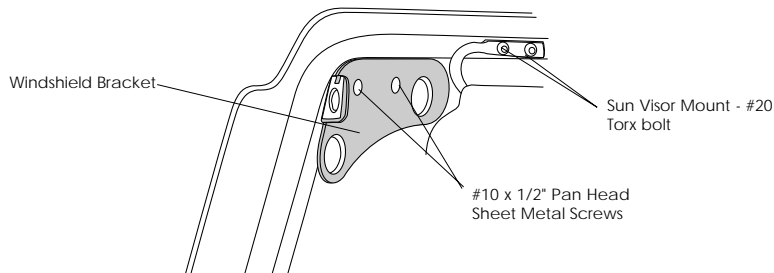

Windshield Bracket

Sun Visor Mount - #20 Torx bolt

#10 x 1/2" Pan Head Sheet Metal Screws

### Tools Needed

1/8", 5/32", 7/32", 3/8" Drill Bits	Flat Screwdriver
and Drill Motor	Phillips Screwdriver
Center Punch	Hammer
#20 Torx - Optional	Pencil
#40 Torx - Optional	Adjustable Wrench
Ratchet	10' Tape Measure
Utility Knife or Razor Blade	

**Warning: Improper windshield adjustment will result in poor fitting top and doors, causing looseness or undue strain on the top.**

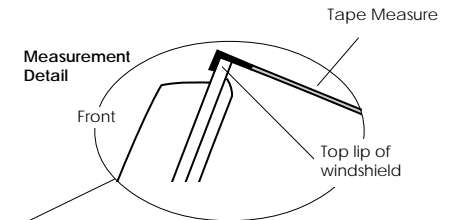

Measurement Detail

Front

Tape Measure

Top lip of windshield

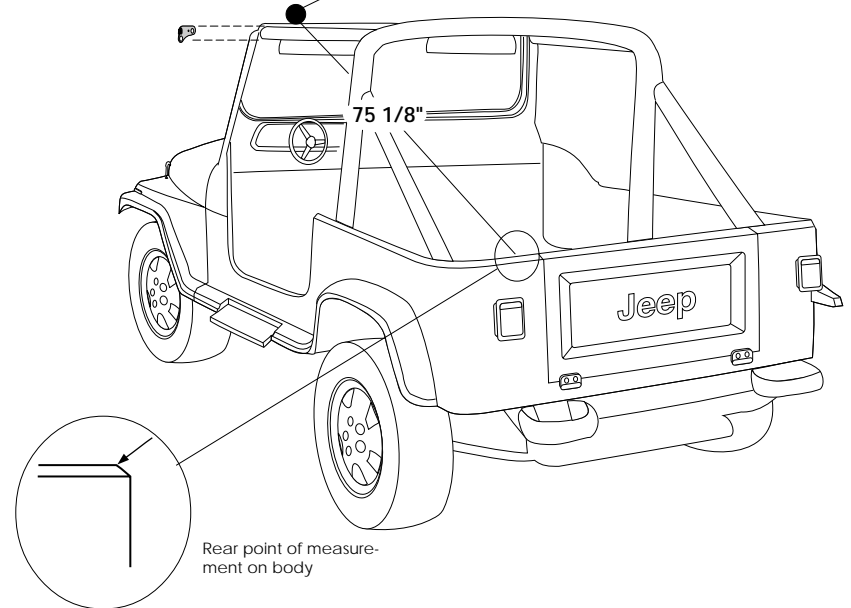

75 1/8"

Rear point of measurement on body

## Please Note

Under most circumstances, the windshield of the Wrangler will not require any adjustment. If your Wrangler windshield should require adjustment, this adjustment should be performed only by an authorized automotive mechanic using a special "Tamper-Proof" Torx head tool.

## Windshield Measurement

Before installing the top, check the windshield measurement. The distance from the top lip of the windshield to the top outer edge of the body must be **75 1/8"** on both sides of the vehicle. Measure 4"-6" inside the doors.

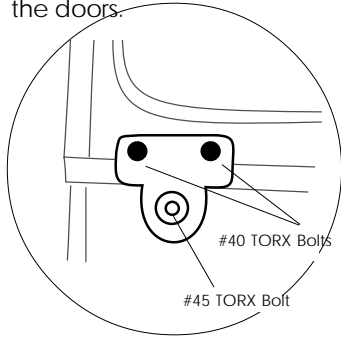

**Wrangler/YJ Windshield Adjustment:** If necessary, loosen the #40 TORX bolts in the windshield clamps to loosen the windshield in order to slip the bracket under the horizontal tube.

## Step One

**Wrangler/YJ:** Use a #20 Torx to remove the outboard sun visor fasteners on both sides of the windshield frame. Remove the two #40 Torx head bolts that secure the horizontal sport bar to the windshield frame. Slide the Windshield Brackets between the windshield and the horizontal sport bar mounts.

Reinstall the Torx head bolts, starting each in the frame with your fingers. After the Torx head bolts are started by hand tighten with your ratchet and Torx drive tool. Do not lay this tool aside until both bolts are completely tightened. If you tighten one of these bolts and the telephone rings - LET IT RING. NEVER LAY THIS TOOL ASIDE OR INTERRUPT THIS PROCEDURE. This procedure should be followed carefully on both sides of the vehicle.

## Wrangler Adjustment

**Warning: Improper windshield adjustment will result in poor fitting top and doors, causing looseness or undue strain on the top.**

## Tools Needed

1/8", 7/32", 3/8" Drill Bits  
and Drill Motor  
Center Punch  
Pencil  
#40 Torx - Optional  
#20 Torx  
#45 Torx - Optional

Flat Screwdriver  
Phillips Screwdriver  
Hammer  
Adjustable Wrench  
10' Tape Measure  
Ratchet

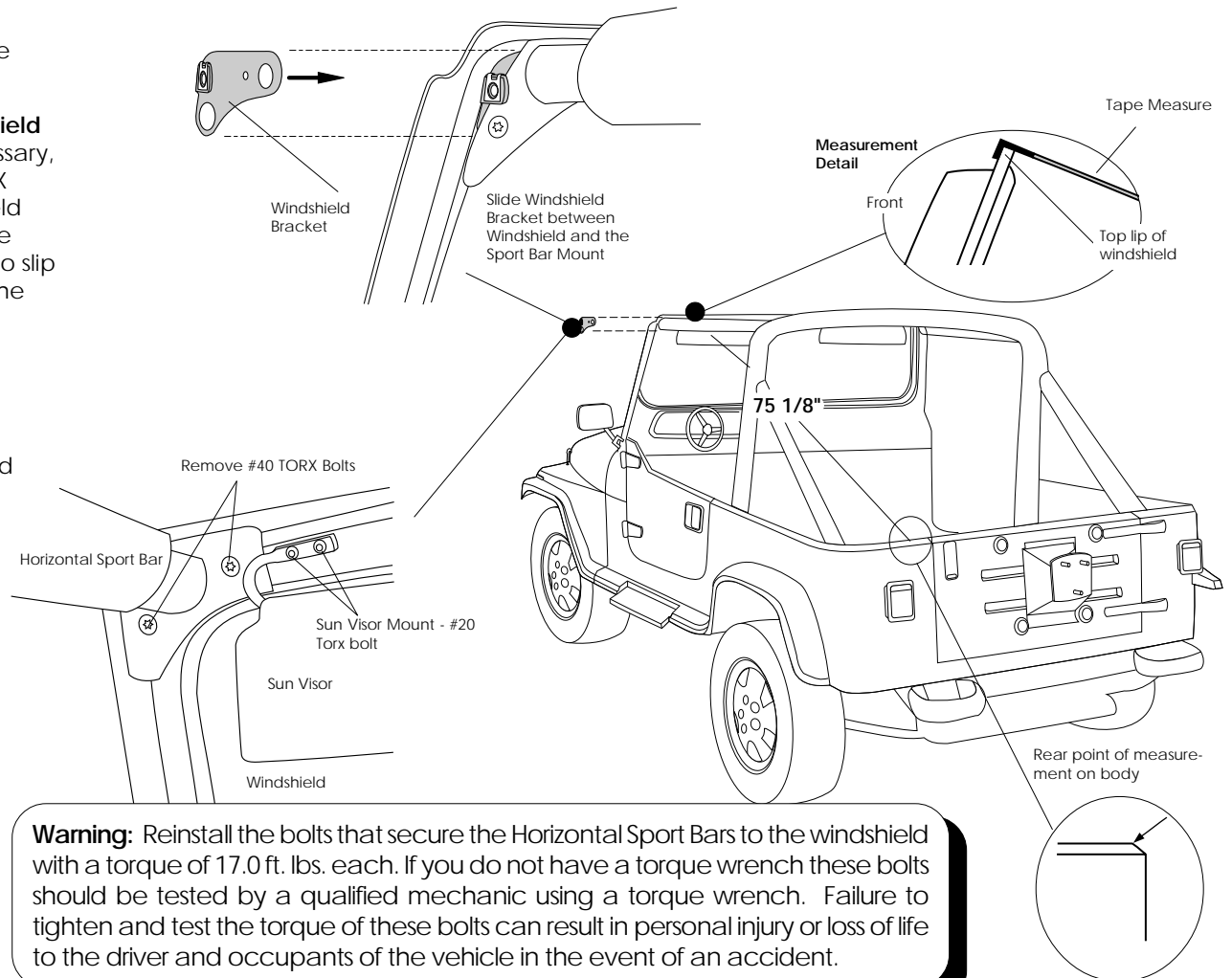

## Step Two

Position the two piece Windshield Retainer on top of windshield frame. Use retainer pieces as templates to mark, center punch and drill eleven 1/8" holes. Install with eleven #8 x 1/2" Pan Head Screws.

**Do not use any drill size other than 1/8". Failure to use the correct size may cause the Windshield Retainer to loosen.**

**Drill 1 hole between the two retainer pieces.**

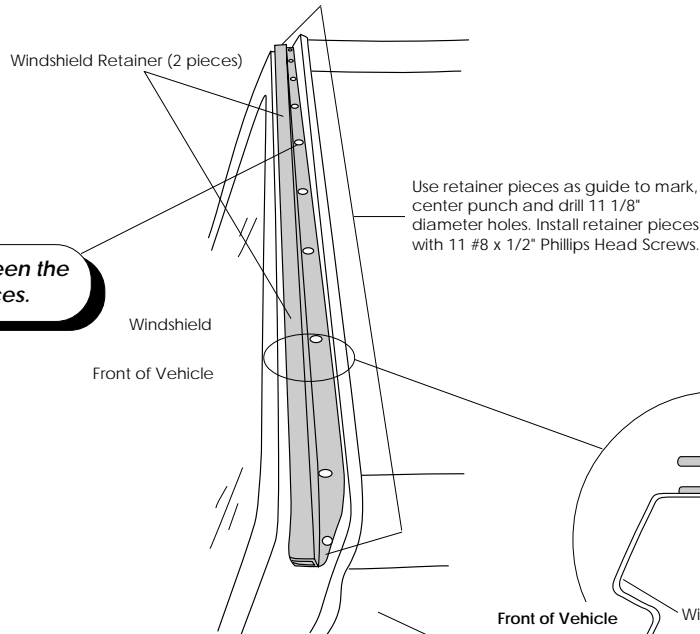

**Warning: A loose Windshield Retainer may allow the top to disengage from the windshield, causing damage to the top and possible injury to the occupants of the vehicle.**

**Make certain that the Windshield Retainer is securely fastened to the windshield during installation and at all other times by checking the tightness of the mounting screws every three months.**

## Step Three

Install the Left and Right Side Belt Rails on each side of the vehicle. Use the Belt Rails as templates to mark, center punch and drill six 3/8" holes along the top edge of the body on each side of the vehicle. Some vehicles may already have four of these holes. Secure the two **rear** holes in the rails with two 5/16" Phillips Head Bolts, two 5/16" Washers and two 5/16" Tapping Plates. **Do not tighten the bolts yet.**

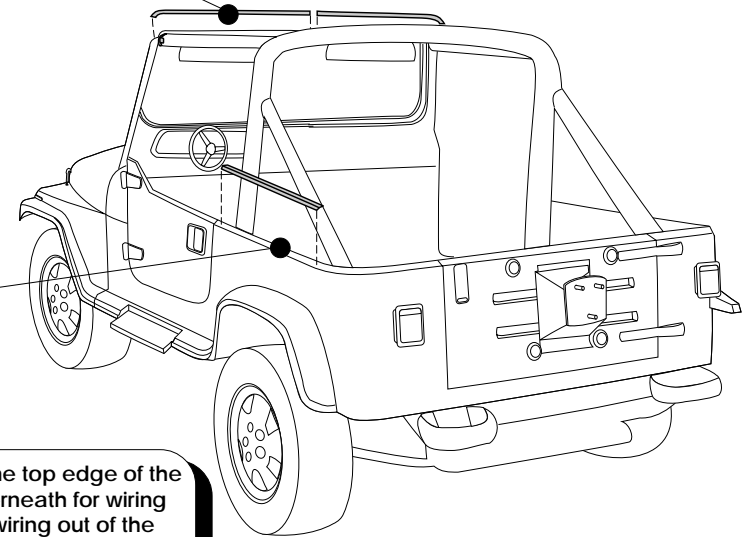
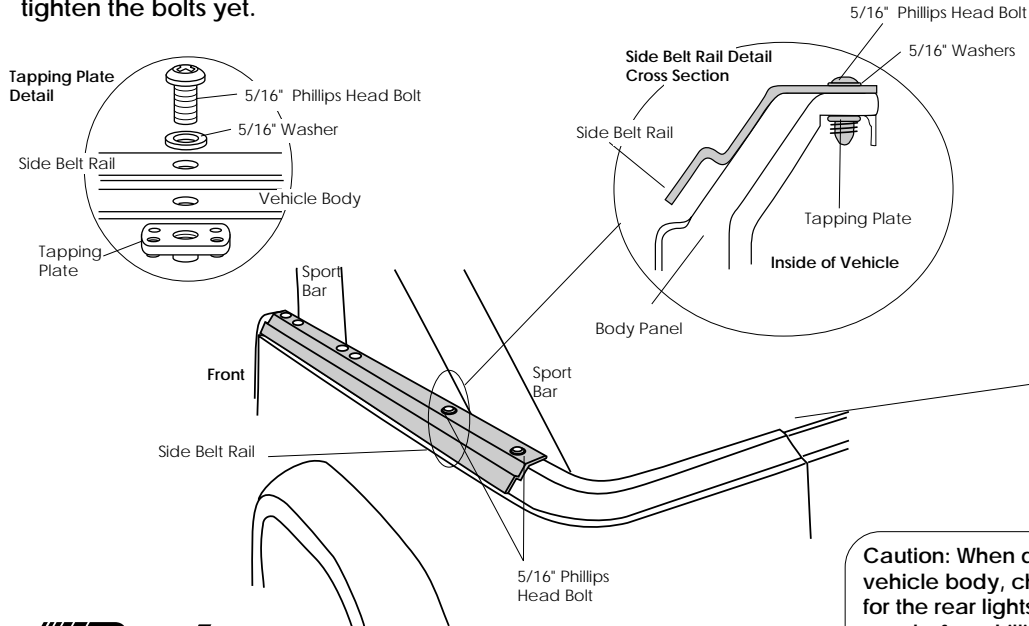

**Caution: When drilling in the top edge of the vehicle body, check underneath for wiring for the rear lights. Pull the wiring out of the way before drilling.**

## Step Four

Install the Left and Right Rear Corner Belt Rails on each side of the vehicle. Notice that the Corner Belt Rails do not butt-up against the Side Belt Rails installed in Step 3, this is normal. Use the Corner Belt Rails as templates to mark, center punch and drill two 3/8" holes in the top edge of the vehicle body. Some vehicles may already have some of these holes. Install the Corner Belt Rails with two 5/16" Phillips Head Bolts, two 5/16" Washers and two 5/16" Tapping Plates. At the location of the remaining hole in the Corner Belt Rail, next to the tailgate, mark, center punch and drill a 1/8" hole. Install a #8 x 1/2" Pan Head Screw. **Do not tighten the bolts yet.**

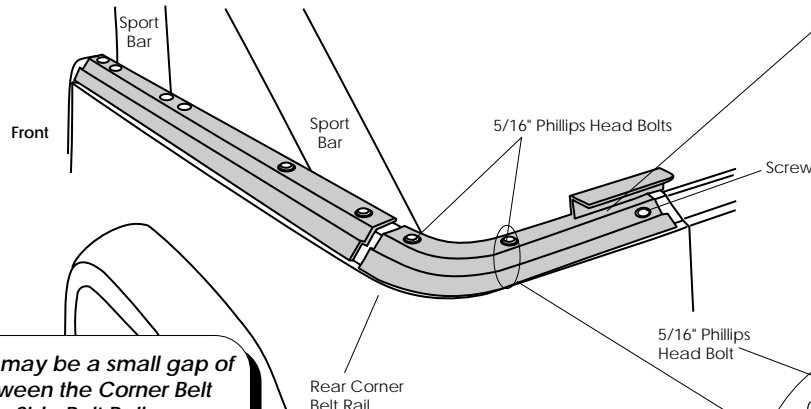
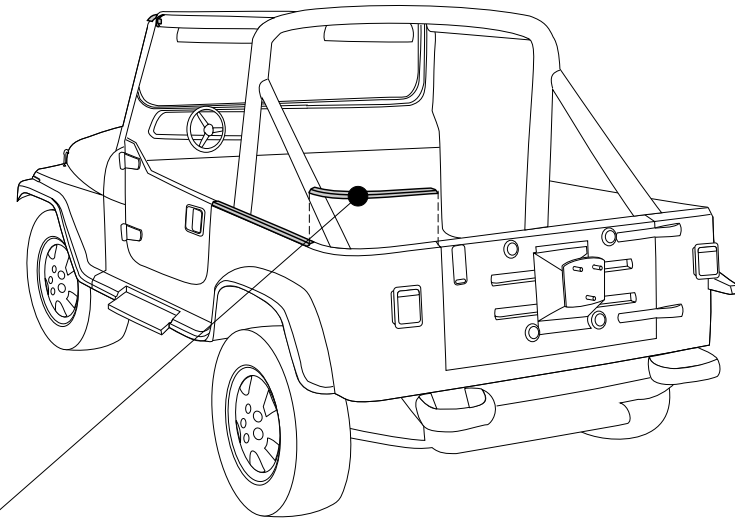

**Note:** There may be a small gap of +/- 1/4" between the Corner Belt Rails and the Side Belt Rails.

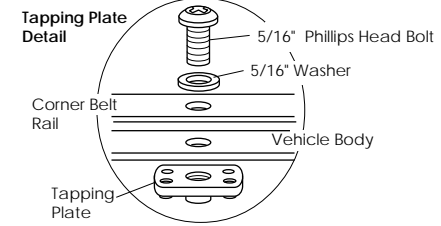
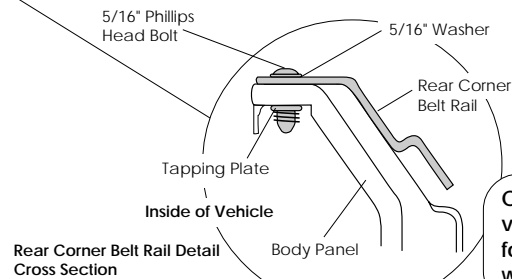

**Caution:** When drilling in the top edge of the vehicle body, check underneath for wiring for the rear lights. Pull the wiring out of the way before drilling.

### Step Five

Install the Vertical Retainer Mounts on top of the Side Belt Rails, just behind the door openings. Secure them in place with two 5/16-18 x 1" Phillips Head Bolts, two 5/16" Washers and two 5/16" Tapping Plates. **Do not tighten the bolts yet.**

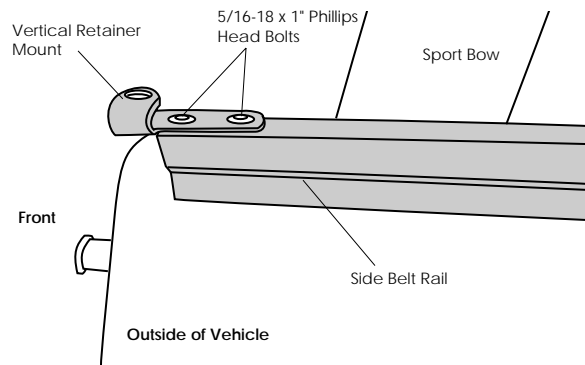
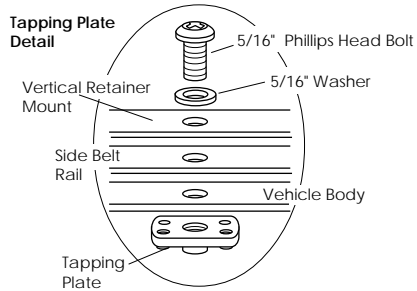
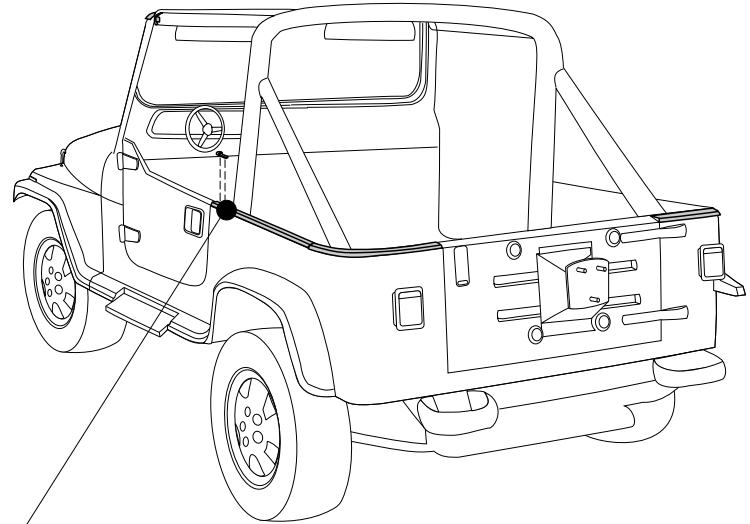

## Step Six

Lay the bow halves on top of the body with the holes in the Bow Mounts over the third and fourth holes in the Side Belt Rails.

**It is important that the white packaging tape remain on the bow assemblies until the forward bolt is tightened on both sides.**

Secure the **FRONT** hole in the Bow Mount with a 5/16-18 x 1" Phillips Head Bolt, a 5/16" Washer and a 5/16" Tapping Plate. Once the front hole is secure, cut the packing tape.

Start the male end of the Top (Front) Bow into the female end. Push forward on the bow until the two sides snap together. Slide the foam pieces on the bow together.

**Once the Bow Mounts are secure, tighten all of the bolts on the Belt Rails.**

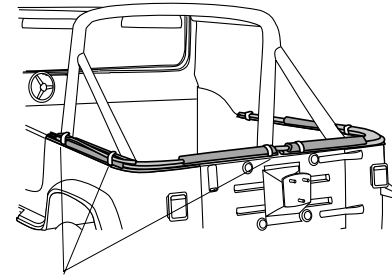

Leave packing tape on Bow Assemblies until front holes of Bow Mounts are secure

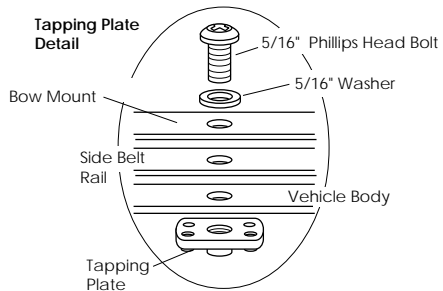
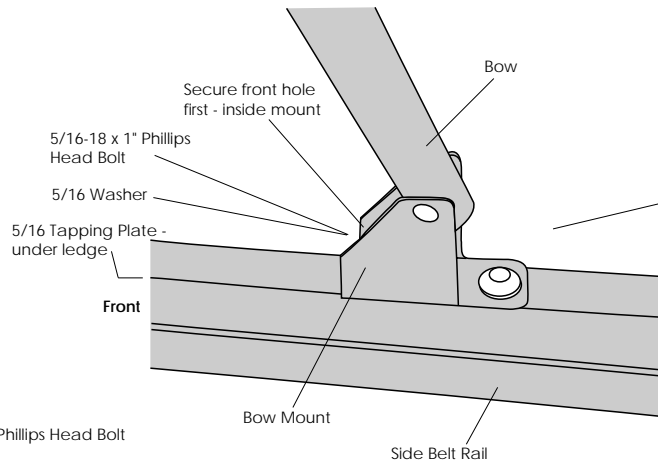
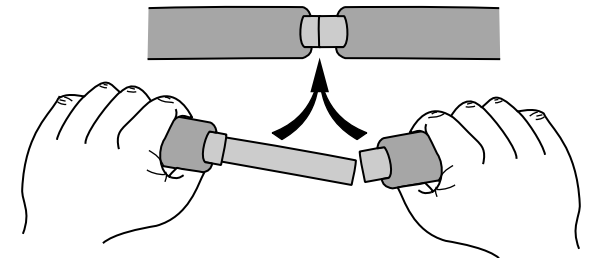
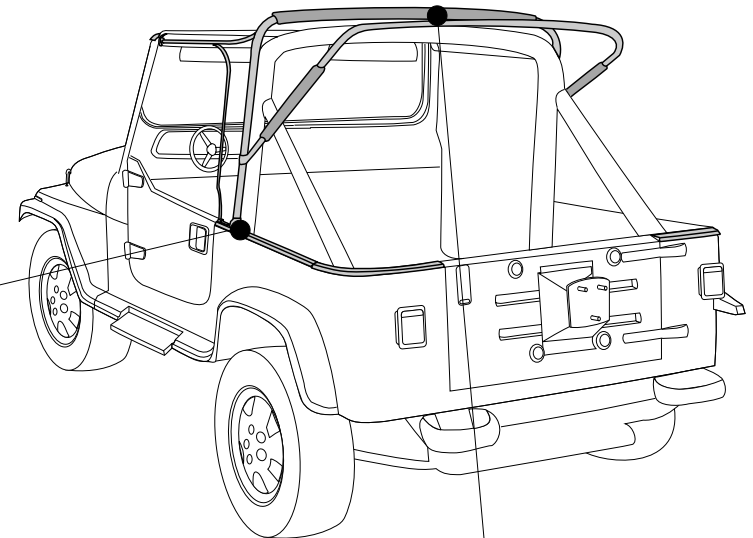



## Step Seven

Release the small metal rods from the plastic clips on both sides of the vehicle.

Lift the Top (Front) Bow and start the male end of the Bottom (Rear) Bow into the female end. Push forward on the bow until the two sides snap together.

Slide the Bottom (Rear) Bow up on the Top (Front) Bow to access the rear bolt position in the Bow Mount. Install and tighten the **REAR** bolt in the Bow Mount on both sides of the vehicle.

Raise the Top (Front) Bow Assembly, holding the small rods in an upright position, and insert the Vertical Rods into the hole in the Vertical Retainer Mount. Attach the Horizontal Rod to the Windshield Bracket using the Bailhead Stud. The pin on the Bailhead Stud will only turn clockwise because of the prongs on the edges of the opening in the Windshield Bracket. Slip the pin through the opening and turn the Bailhead Stud a quarter turn clockwise so that the flanges on the pin are secure between the prongs.

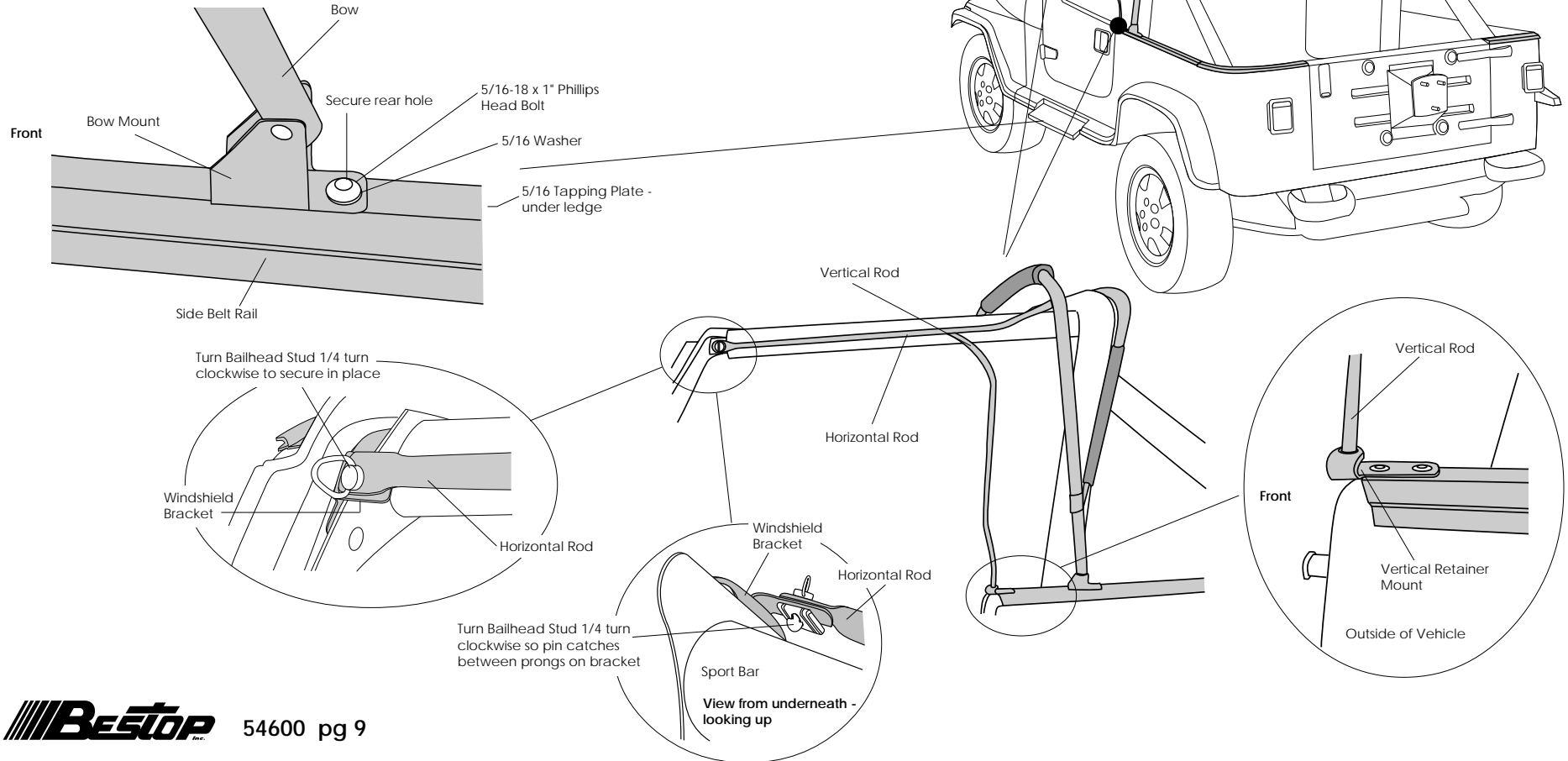

## Step Eight

Locate the top and orient it on the vehicle. Drape the top over the bows and insert the plastic strip sewn along the front of the top into windshield retainer. Do not catch the fabric in the retainer. Center the front of the deck on the vehicle so that it is an equal distance from the top of the windshield flange on both sides.

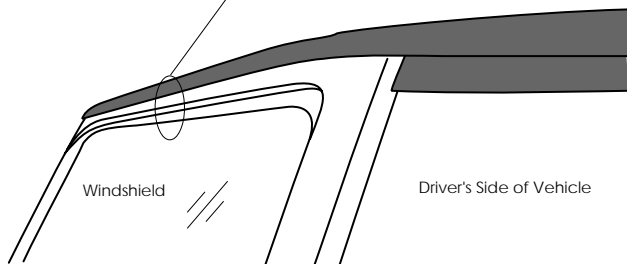
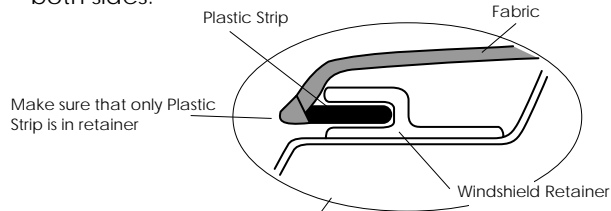

**Note:** For best possible installation, check to make sure that the soft top is perfectly centered on the vehicle.

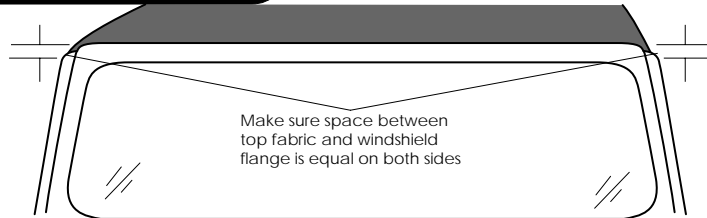

View from front

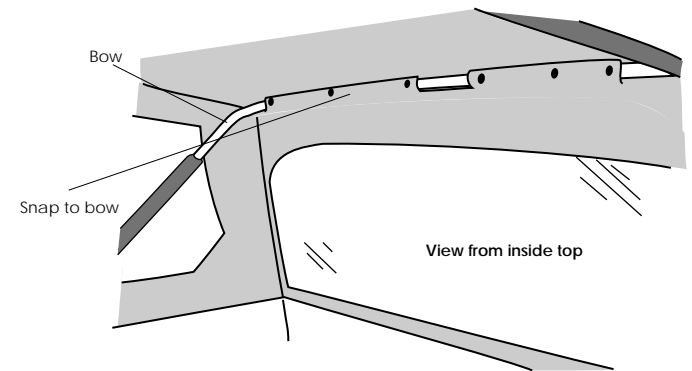
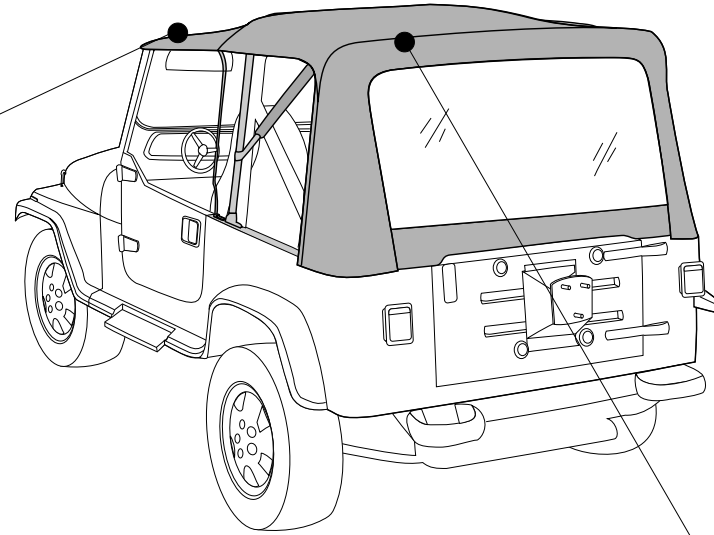

**Note:** If the snaps don't appear to line up, push the rear bow forward to relieve the pressure on the bow. This will allow the snaps to line up more easily.

## Step Nine

Snap the flaps to the six studs on the rear bow.

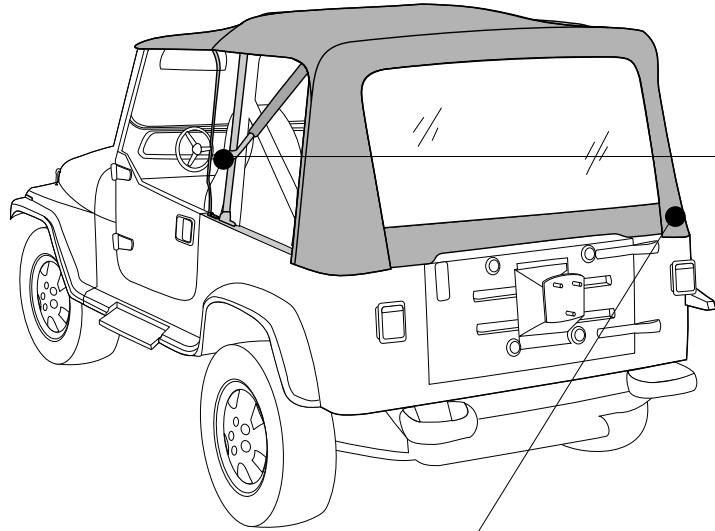

### Step Eleven

Slide the Rear Bow up on the Front Bow and insert the small bent tab into one of the four holes in the Front Bow.

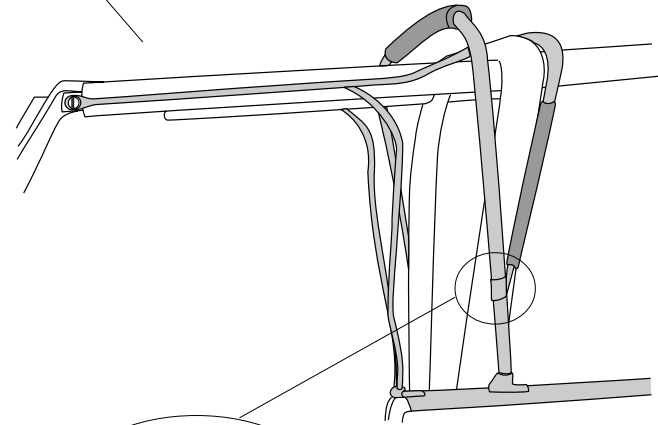

### Step Ten

Insert the black plastic strips at rear corners of top into Corner Belt Rails. There is a plastic reinforcement sewn into the corner of the top, in addition to the plastic strip.

Make sure that the reinforcement is not caught under the Corner Belt Rail.

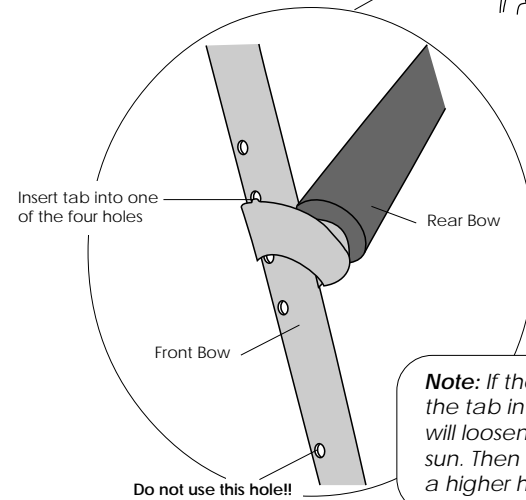
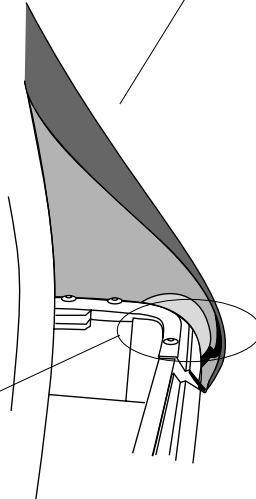
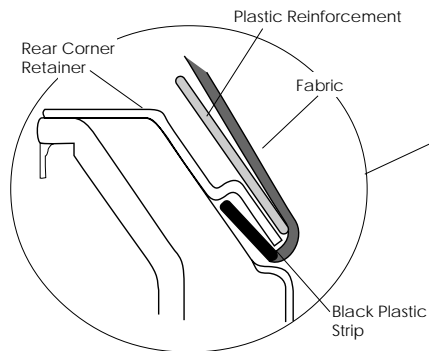

**Note:** If the top is extremely tight, slip the tab into the bottom hole. The top will loosen up after a few hours in the sun. Then the tab may be inserted into a higher hole position.

## Step Twelve

Start top and rear zippers on side curtain 6 inches.

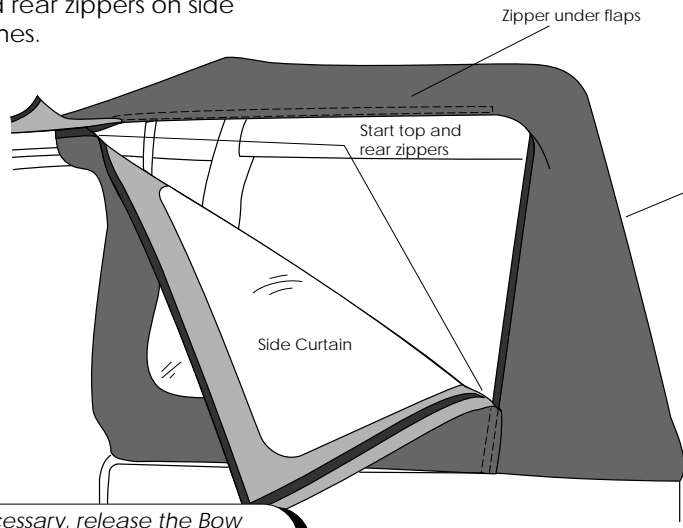

**Note:** If necessary, release the Bow Coupler and slide the top around the Corner Belt Rail towards the window to make it easier to start the zippers on the Side Curtains.

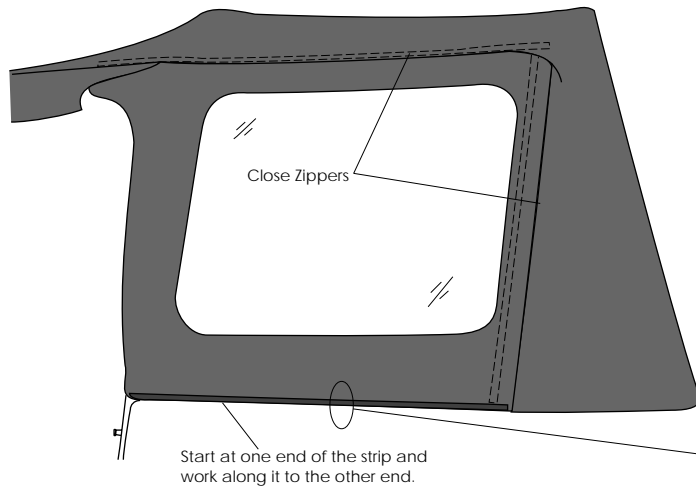

## Step Thirteen

Slip the plastic strip on the bottom of the side curtain into the side retainer. Close the top and rear zippers on the side curtain.

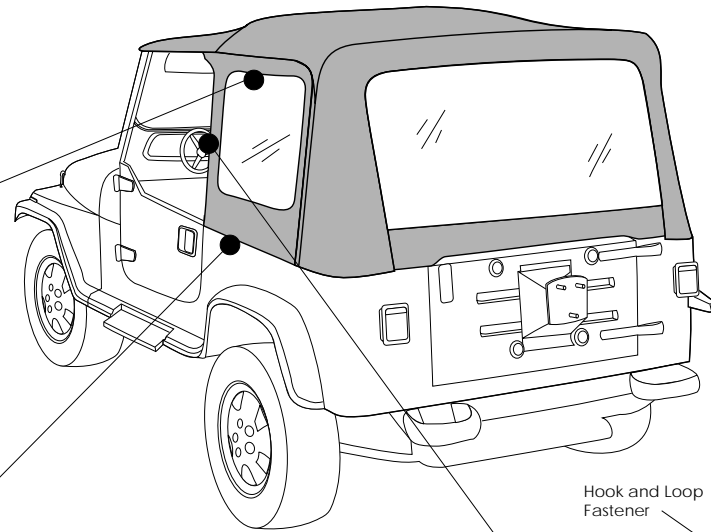
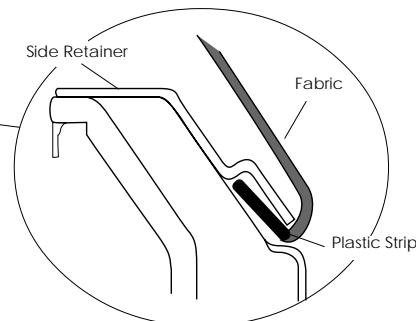

## Step Fourteen

Wrap fabric flap on the front of the side curtain around the Vertical Rod (not the front bow) and fasten the hook and loop strips to each other.

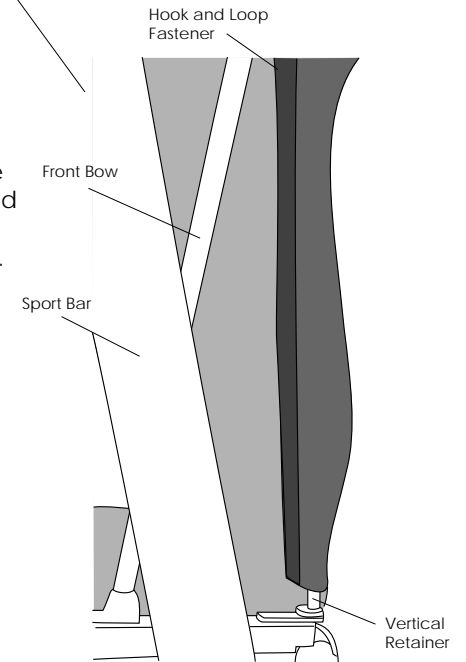

View from inside vehicle - Driver's Side

## Step Fifteen

Wrap the flap, sewn to the top above each door, around the Horizontal Rod and fasten the hook and loop strips to each other. The foam pillow with the flat surface must be on the inside of the horizontal rod for full, steel door use.

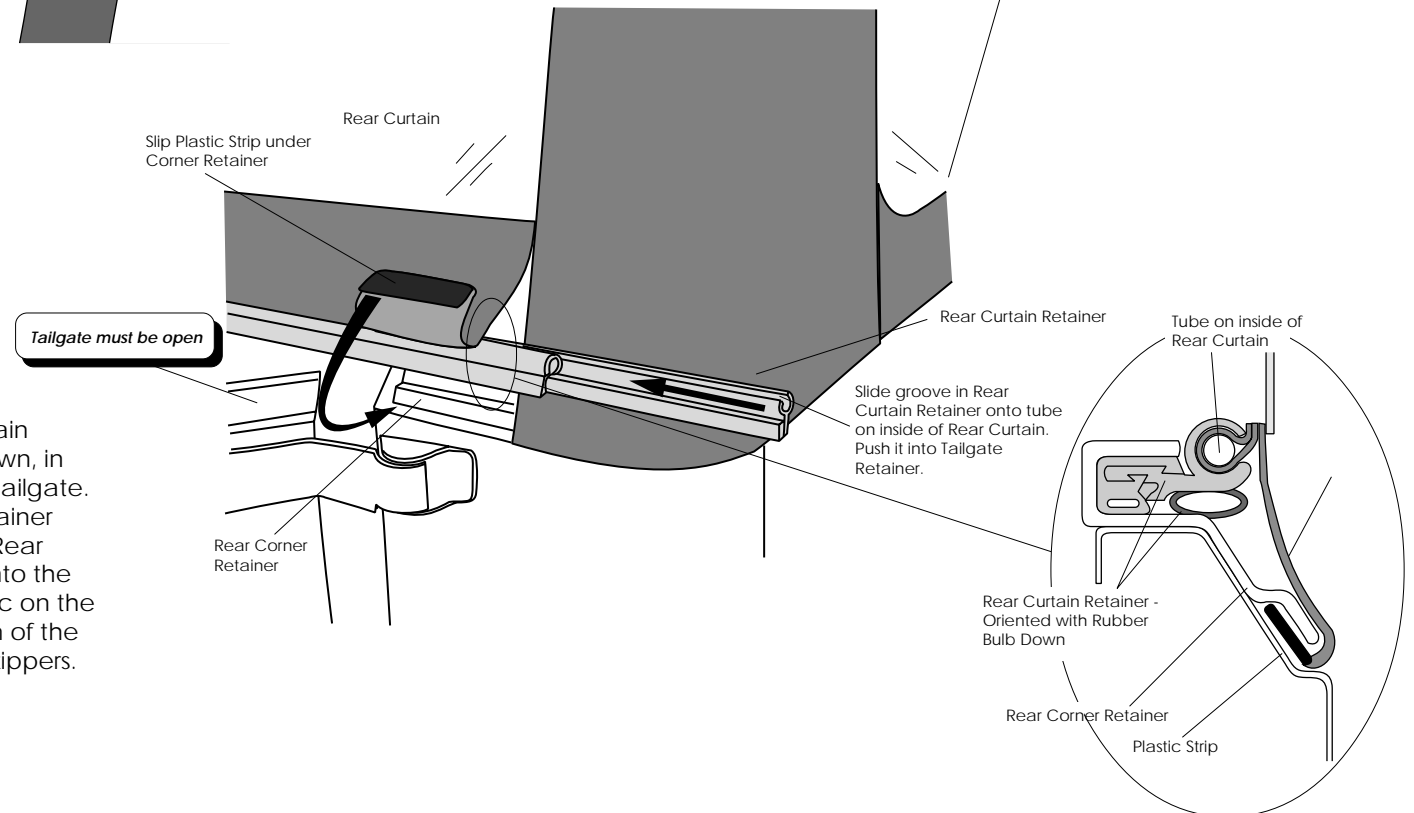
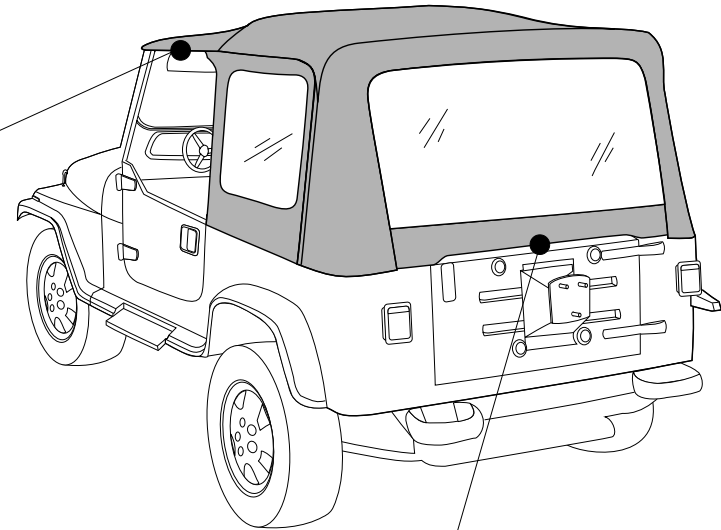
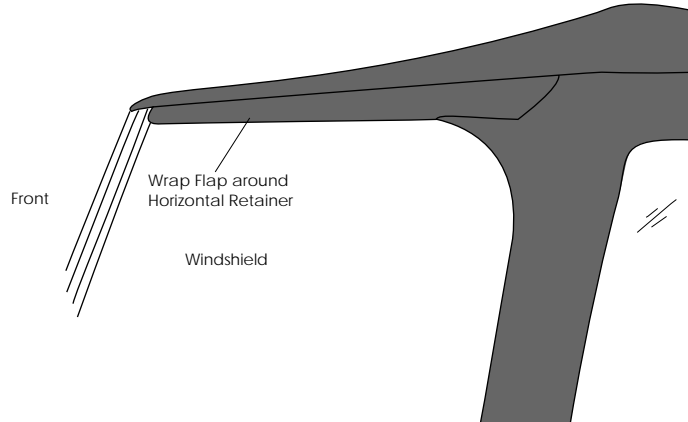

## Step Sixteen

Open the tailgate. Orient the Rear Curtain Retainer with the rubber bulb facing down, in order to form a seal with the top of the tailgate. Slide the groove in the Rear Curtain Retainer onto the tube inside the bottom of the Rear Curtain. Roll the Rear Curtain Retainer into the top of the Corner Belt Rail. Slip the plastic on the bottom of the corners under the bottom of the Corner Belt Rail. Close the rear curtain zippers.

## Step Seventeen

Installing the upper door into the lower steel door, start with the front pin and slip the pins into the sockets in the lower door. Make sure that the pins are well seated in the sockets. Close the door to check that it fits properly against the body. If necessary, use a 1/8" Allen Wrench to loosen the Collars on the front and rear upper door pins. The Collars will slide up or down as needed to provide the best fit of the Upper Door against the windshield and the Horizontal Rod plastic.

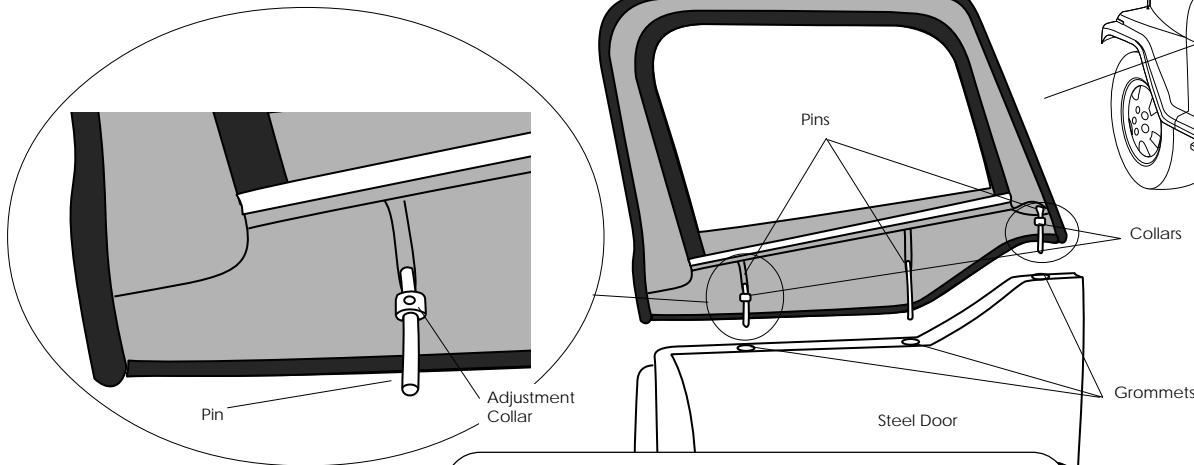

**Special Note:** This door may be installed on 1986-1987 vehicles, however, the door retainer in Step Nineteen must first be purchased from your dealer.

**Warning:**  
The doors in this product are designed only for protection against the elements. Do not rely on the doors to contain occupants within the vehicle or to protect against injury during an accident. Door handles are only designed to aid in door closure. Door and handle **will not** support a person's weight.

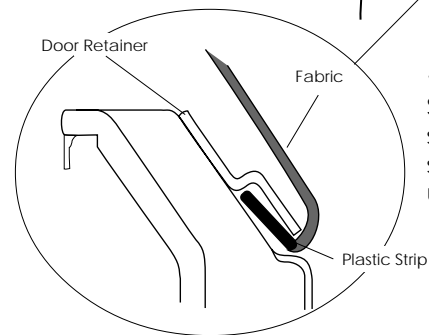
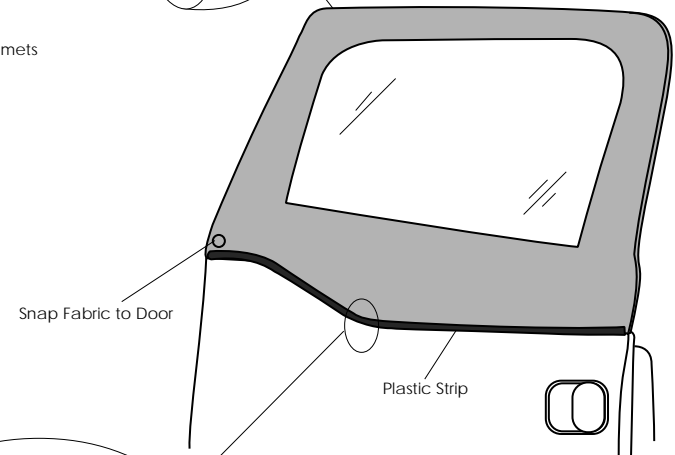
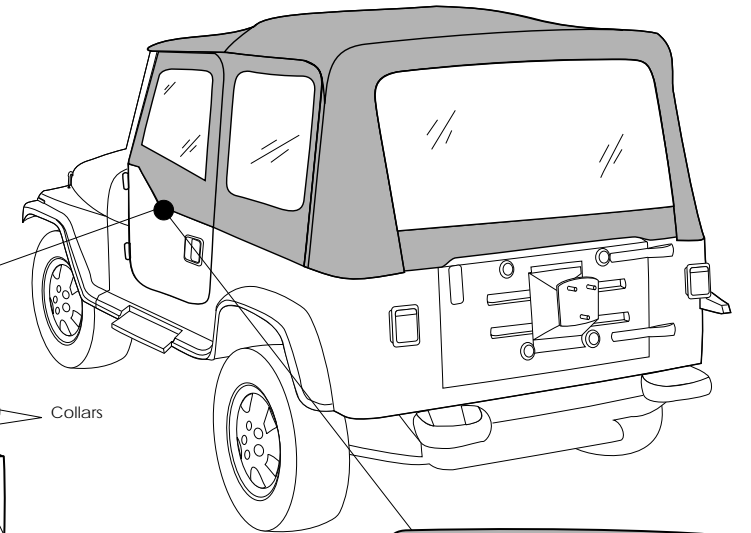

## Step Eighteen

Slip plastic strip on the bottom of the soft door into the Door Retainer on the steel door. Fasten the snap at front of upper door.

**Warning:** When operating the vehicle without the Side Curtains, the Rear Curtain should be rolled up for proper ventilation.

## Adjusting the Top

### Side Curtains

To remove the Side Curtains. Unzip the rear and top zippers. Release the plastic strip from the retainer. Release the Hook and Loop Fasteners from around the Vertical Retainer.

### Rear Curtain

To roll up the Rear Curtain, remove the Rear Curtain Retainer and start at the bottom, rolling it to the inside. Avoid wrinkles in the fabric and window. Secure it in place with the curtain straps inside of the top.

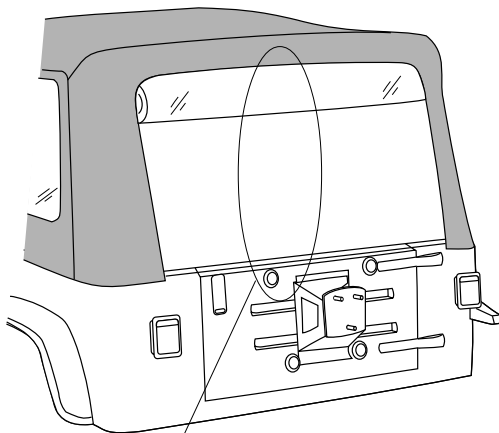

Detail of Rear Curtain

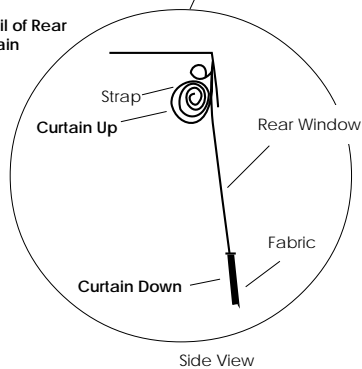

Side View

### Folding the Top Down

Open the zippers at the rear of the Side Curtains. Pull the plastic strip on the bottom of the Side Curtains out of the Belt Rails. Leave the rear corners of the top attached to the Corner Belt Rails. Unfasten the hook and loop strips at the front of the Side Curtains, releasing the Side Curtains from the Vertical Retainer. Fold the Side Curtains up onto the top and release the hook and loop fasteners on the flaps, above the doors. Unsnap the top from the rear bow.

Release the locking tabs on the Bow Releases from the holes in the bow and slide the rear bow down to the Bow Mounts. Release the Horizontal Rod from the Windshield Bracket. Remove the Vertical Rod from the Vertical Retainer Mount and lay the bow assembly down on the rear of the vehicle.

Unfasten the top from the windshield and lay it down on the body. Make sure that the rear corners of the top are tucked under the rear bow. Fold the top in half from front to back and continue folding until the top is about 1 foot wide at the rear of the vehicle. Secure the top by clipping the Bow Tie Downs into the Side Belt Rails.

### Removal of Soft Top for Open Air Driving

When operating the vehicle with the fabric top removed, it is very important that the supporting hardware system be disconnected from the windshield bracket and folded flat to the rear of the vehicle. The vertical and horizontal rods should be snapped into the plastic clips located on the inside of both bow mount brackets. Wrap the elastic straps around the bows and insert the plastic strip into the side belt rail. Never operate the vehicle with the fabric removed and the hardware in the fully erected position.

## Care and Maintenance of your Bestop Top

Your top is made of the finest materials available. To keep it looking new and for the maximum possible wear, it will need periodic cleaning and maintenance.

**Washing:** The top fabric should be washed often using soap, warm water and a soft bristle brush. Rinse with clear water to remove all traces of soap.

**Windows:** Keep windows clean to avoid scratching. DO NOT use a brush on the windows! Wash with a watersoaked cloth or sponge and a mild dishwashing detergent. NEVER WIPE THE WINDOWS WHEN THEY ARE DRY. Be careful when cleaning snow or frost from the vinyl windows since they are easily scratched and may crack at low temperatures. DO NOT roll the sides or rear window in cold weather. The windows become stiff and will crack.

**Zippers:** Keeping the zipper cleaned and lubricated with a silicone lubricant will help prevent damage and keep the zippers in a smooth working condition. If a zipper opens behind the slider, the slider may have been spread apart. This problem can usually be repaired by using an ordinary pair of pliers to bring the sides back into parallel. Return slider to the end of the zipper in the normal Open position. Squeeze lightly at first and test the zipper. If the zipper continues to remain open squeeze more firmly with the pliers and try the zipper again. Repeat this procedure until the zipper operates correctly.

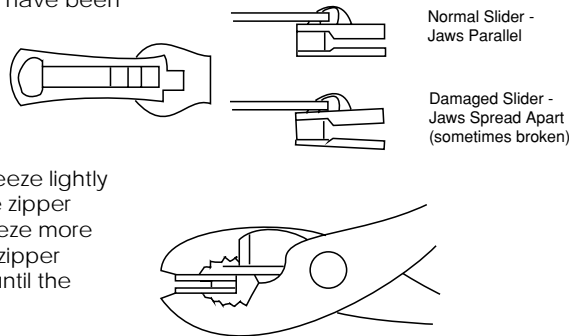

**Water:** Seeping through at the seams may be stopped by applying 3-M Scotchgard® on the inside of the seams. Rips in the fabric may be repaired with Bondex® iron on patches. Iron the patches to the inside of the top, carefully following the Bondex® instructions.

**Snaps:** Keep snaps cleaned and lubricated with silicone to help prevent snaps from sticking to the studs. If a snap does become stuck to a stud, use a screwdriver and GENTLY pry apart to prevent permanent damage to the snap or the top fabric.

## LIMITED WARRANTY

We warrant our product to be free from defects in material and workmanship, for the terms specified below, provided there has been normal use and proper maintenance. This warranty applies to the original purchaser only. All remedies under this warranty are limited to the repair or replacement of any item or items found by the factory to be defective within the time period specified.

If you have a warranty claim, first you must call our factory at the number below for instructions. You must retain proof of purchase and submit a copy with any items returned for warranty work. Upon completion of warranty work, if any, we will return the repaired or replaced item or items to you freight prepaid. Damage to our products caused by accidents, fire, vandalism, negligence, misinstallation, misuse, Acts of God, or by defective parts not manufactured by us, is not covered under this warranty.

THE WARRANTY TIME PERIOD IS AS FOLLOWS: ALL "SOFT GOODS" MANUFACTURED BY OUR COMPANY (USING PRIMARILY VINYL, PLASTICS, AND/OR FOAM): ONE YEAR FROM DATE OF PURCHASE.

ANY IMPLIED WARRANTIES OF MERCHANTABILITY AND/OR FITNESS FOR A PARTICULAR PURPOSE CREATED HEREBY ARE LIMITED IN DURATION TO THE SAME DURATION AND SCOPE AS THE EXPRESS WRITTEN WARRANTY. OUR COMPANY SHALL NOT BE LIABLE FOR ANY INCIDENTAL OR CONSEQUENTIAL DAMAGE.

Some states do not allow limitations on how long an implied warranty lasts, or the exclusion or limitation of incidental or consequential damages, so the above limitations or exclusions may not apply to you.

This warranty gives you specific legal rights, and you may also have other rights which vary from state to state.

For further information or request for warranty work, please contact:

Bestop Inc.  
Customer Service  
(800)845-3567  
(303)465-1755

