

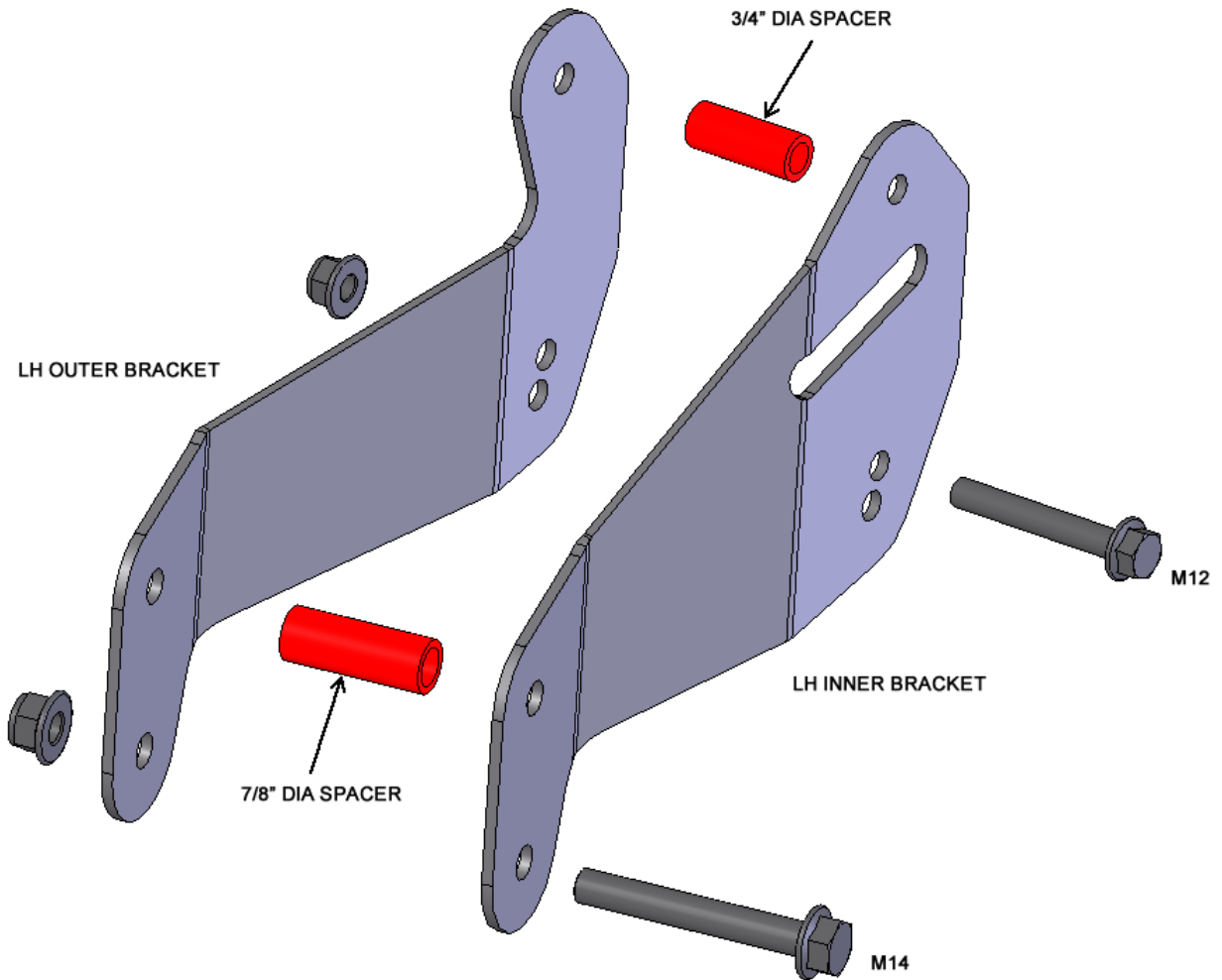

AMERICAN EXPEDITION
VEHICLES

JK FRONT CONTROL ARM DROP BRACKETS



(LH BRACKETRY SHOWN - RH SYMMETRICALLY OPPOSITE)

Installation Guide - AEV30102AA

(Updated 04/28/10)



PLEASE READ BEFORE YOU START

IN ORDER TO INSTALL THIS PART PROPERLY YOU OR YOUR INSTALLER MUST READ THESE INSTRUCTIONS THOROUGHLY BEFORE BEGINNING THE INSTALLATION. FAILURE TO DO SO MAY RESULT IN MISTAKES AND AFFECT THE QUALITY OF THE FINISHED PRODUCT.

Included Parts	QTY	Required Tools
LH Outer Bracket	1	Common Hand Tools
LH Inner Bracket	1	
RH Outer Bracket	1	
RH Inner Bracket	1	
Hardware Pack	1	
7/8" DIA SPACER	2	
3/4" DIA SPACER	2	
M14 HEX BOLT	4	
M14 HEX LOCK NUT	4	
M14 WASHER	8	
M12 HEX BOLT	2	
M12 HEX LOCK NUT	2	
M12 WASHER	4	



A. Installation with AEV JK 3.5"/4.5" Suspension Kits

1. These drop brackets are engineered to work with AEV 3.5" and 4.5" suspensions. They will also work with other suspension brands, however it is important your vehicles ride height falls within the specified range. If you are installing these brackets with a Non-AEV suspension, proceed to Section B for instructions on measuring ride height.
2. **NOTE: This installation is best performed with all four wheels on the ground.**
3. **WORK ON ONE SIDE AT A TIME!** Remove the upper and lower control arm bolts at the frame end and save the factory hardware. **NOTE: Depending on the build of your vehicle you might need to pry the exhaust out of the way to remove and install the RH upper control arm bolt (M12).**
4. Install the brackets as shown below (LH side brackets illustrated). Use the factory hardware and supplied spacers (which will fill the void for the control arms) in the original control arm mounting locations.

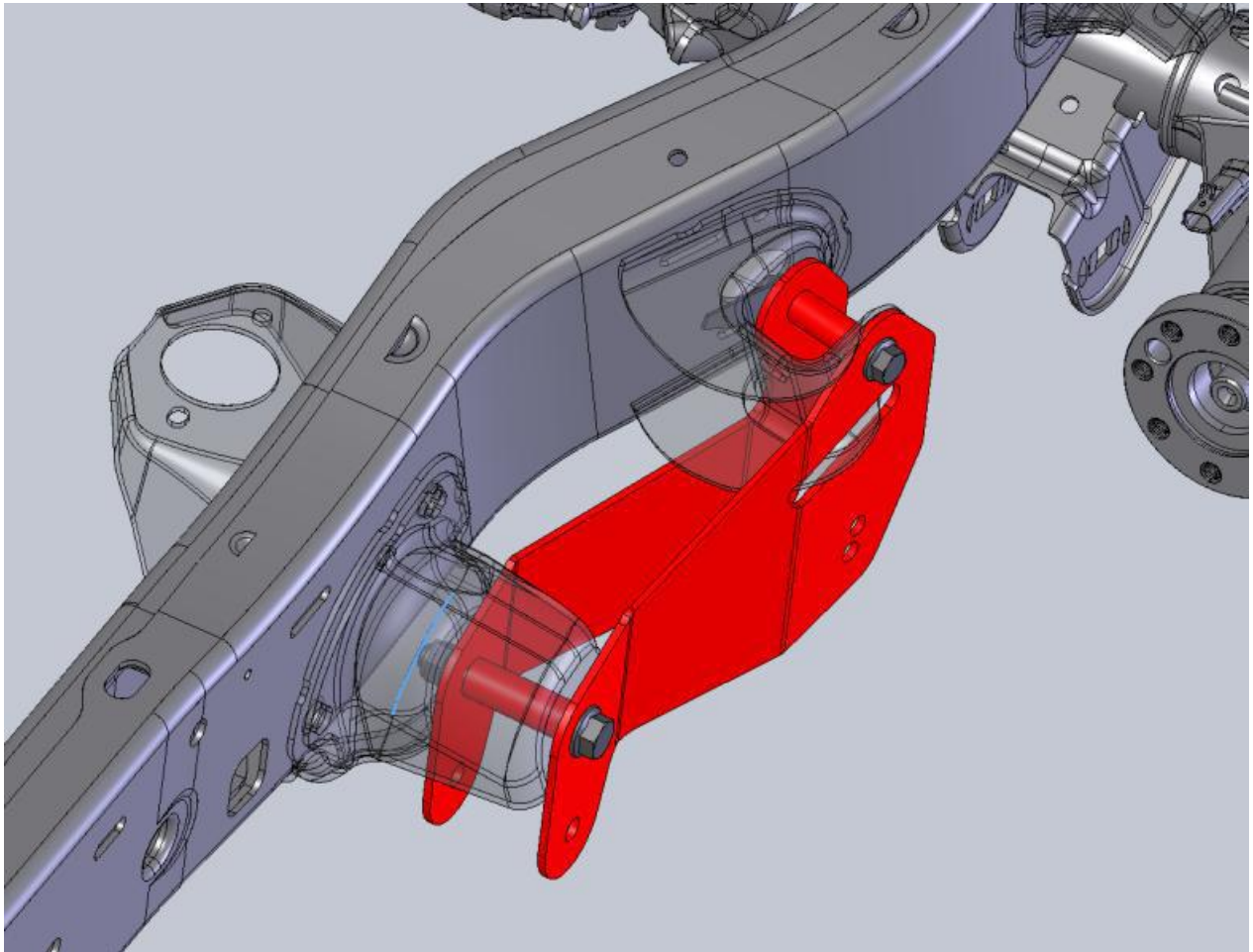



AMERICAN EXPEDITION
VEHICLES

5. Use the supplied hardware to mount the control arms in the new dropped locations (M12 fasteners for the upper control arms and M14 for the lower control arms).
6. NOTE: There are two relocation holes in the brackets for mounting the upper control arms. If you are installing the AEV 3.5" Suspension Kit, use the upper hole location, and if you are installing the AEV 4.5" Suspension Kit, use the lower hole as shown below.

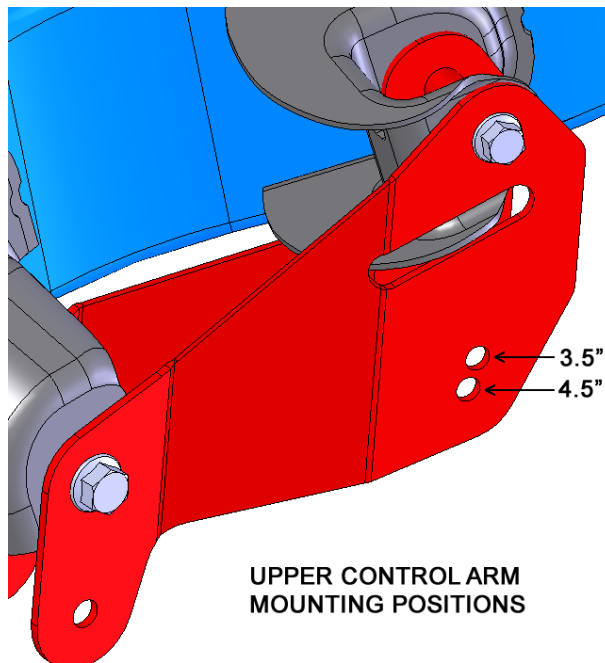
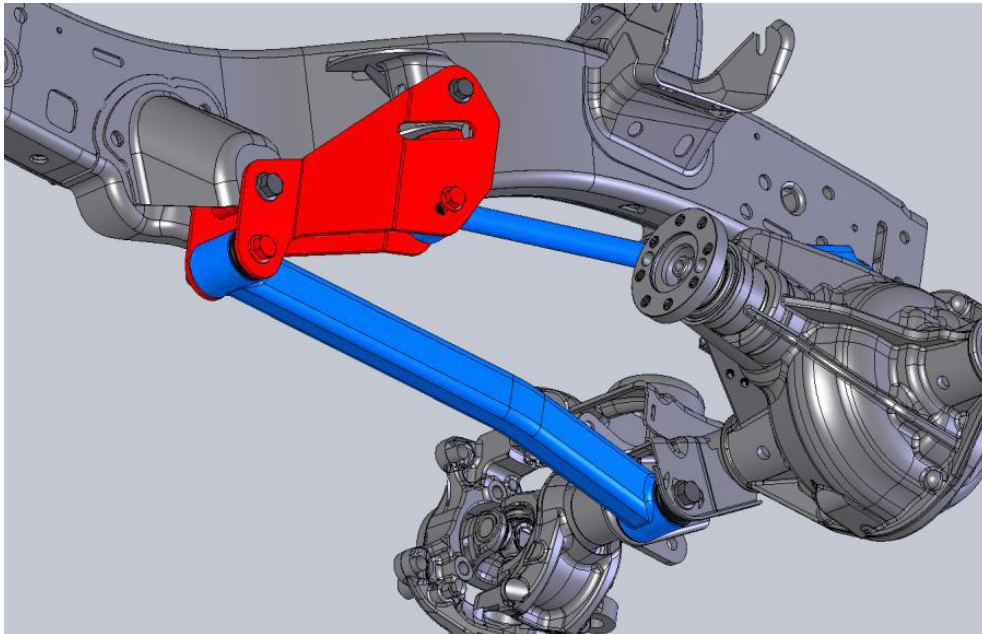



IMPORTANT: If you are installing this kit to a previously installed suspension system that utilized cam bolts, you'll want to remove and discard them and replace with supplied hardware (M14 bolt, nut, and two thick washers). You can tack weld the washers to add more support.

B. Installation with Non-AEV Suspension Kits

1. You'll first need to get a measurement from your vehicle to determine whether or not you should be using the drop brackets. Measure from the bottom of the frame to the top of the spring seat as illustrated below.

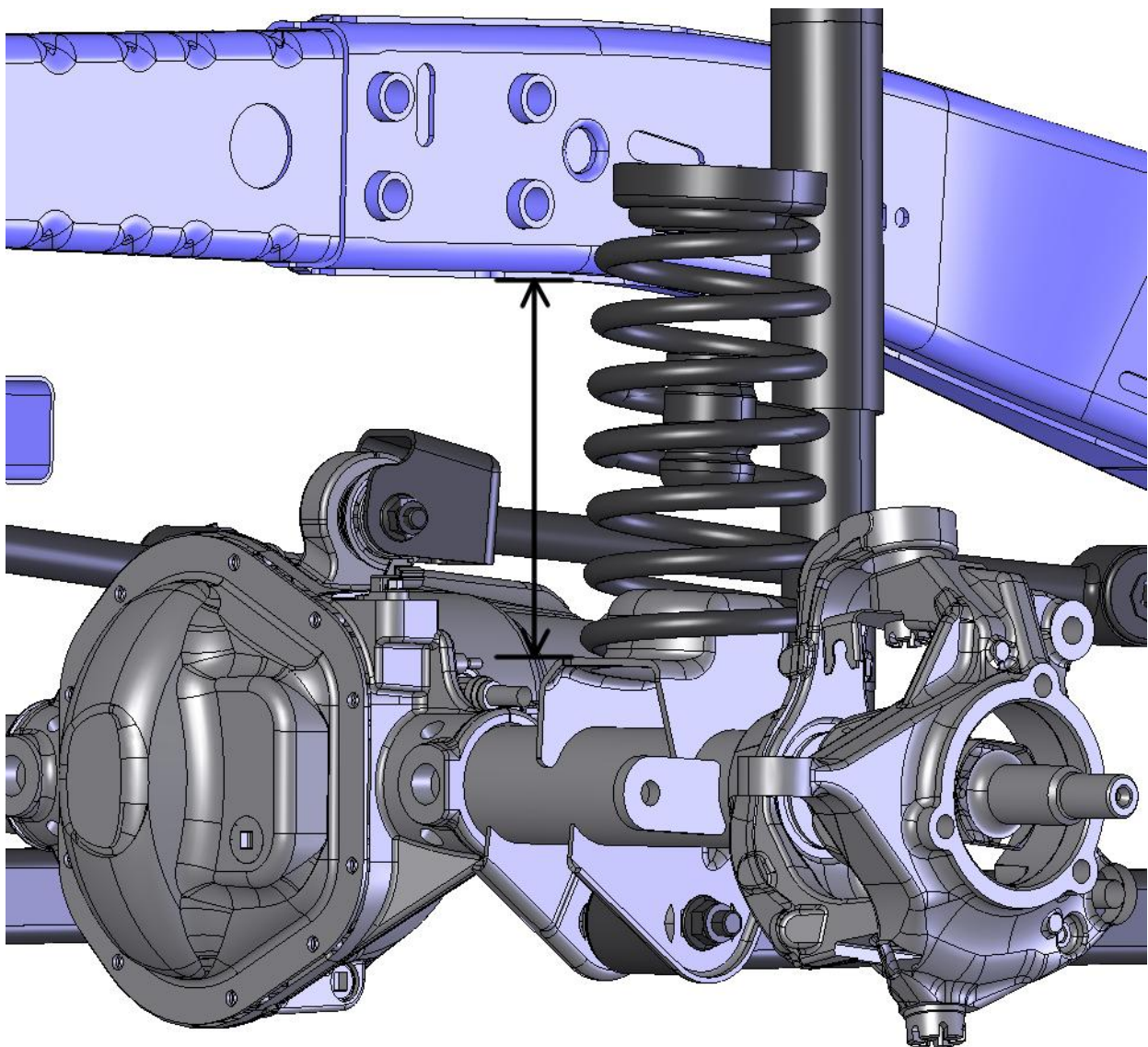



2. **NOTE: If your measurement is less than 7 inches we do not recommend these brackets.**
3. If your measurement is greater than 9 inches adjustable control arms may be required to achieve proper caster angle.
4. If your measurement is from 7 to 8 inches you'll install the upper control arm in the upper hole location (3.5") as illustrated on page 4.
5. If your measurement is from 8 to 9 inches you'll install the upper control arm in the lower hole location (4.5") as illustrated on page 4.
6. You can now proceed to step "A" to finish the installation of the drop brackets.

COMMENTS OR QUESTIONS?

Be sure to visit our forum at: <http://forum.aev-conversions.com>

American Expedition Vehicles

Phone: 406.251.2100

Email: tech@aev-conversions.com

Website: <http://www.aev-conversions.com>