

# Jeep Wrangler 'EX' Extended Coverage

Set Part # 10903  
Rev 3 12/08/09

## Step 1: Prior to Installation:

- A) Bushwacker only approves installing the flares according to these written instructions with the hardware provided. **WARNING:** Failure to install according to these instructions will invalidate the warranty. This includes, but is not limited to using alternative installation methods, hardware, or materials. **DO NOT USE:** Loctite, SuperGlue, or similar products on the hardware or the flares.
- B) **Fit:** Verify the fit of the flares to vehicle. **(Some filing, sanding, or cutting may be necessary to ensure proper fit).**
- C) **Painting:** (Optional) if paint is desired it must be done prior to installing flares on the vehicle clean outer surface with a good grade degreaser. **DO NOT USE LACQUER THINNER OR ENAMEL REDUCER AS A DEGREASER.** Wipe outer surface thoroughly with a tack rag prior to paint.  
Paint flares using a high quality enamel, or polyurethane automotive paint. (Application of a primer coat is optional)  
If painting edge trim (not recommended), use a flex additive.
- D) **Performance:** Using larger Tires may increase the area required to turn the vehicle. Some Tire/Rim combinations may require lowering bump stops and or installing steering stops to prevent tire from contacting flare.
- E) **Exhaust System:** Modifications may be necessary to maintain a minimum 4" clearance between flares and exhaust pipes. (Exhaust gases should not vent directly onto flares)
- F) **Metal Protection:** All exposed fasteners and bare metal should be treated with red oxide primer BEFORE installing flares.
- G) **Local Vehicle Regulations:** This kit contains hardware for the relocation of front fender mounted turn signals only. Check local laws to avoid possible violations which could result from these changes.



## TOOLS FOR EASY INSTALLATION

- Jack and Jack Stands
- Electric Drill
- 11/64" Drill Bit
- 1-1/8" Hole Saw
- Pop Rivet Gun
- Grease Pencil or Marking Pen
- Tape Measure
- Phillips Screw Driver
- Wire Crimper
- Wire Strippers
- Red Oxide Primer

---

## FLARE INSTALLATION PROCEDURES

### Step 2: Preparing the Work Area (Front)

- A) Remove tire using jack and jack stands should additional room be required to work in the wheel well area.
- B) Remove factory flares from all wheel openings.
- C) Disconnect signal light bulb assembly from signal light frame and remove frame from fender. Save signal frame for reinstallation.

### Step 3: Installing Flares (Front) (See Illustrations #1 & #2)

Front flares are two part construction: the flare itself and an end cap which covers and extends the lower rear portion of the flare.

- A) Drill twelve 9/64" holes through the flare and end-cap lip at the locations shown in **Illustration #1**. Holes should be drilled from the back to avoid marring the outer flare surface. Screw locations are marked as indents on the lip.
- B) Remove one side of the protective paper backing from the double-stick tabs and press onto the inside surface of the lip and over the holes drilled in Step 3A. **See Illustration #3.**
- C) Remove remaining paper backing and press flare and end-cap into position on fender. Shield flare surface with duct tape or use drill bit extension to prevent marring by drill chuck and drill twelve 9/64" holes in fender through hole drilled in Step 3A.
- D) Secure flare to fender using supplied drill screws through washer. Press caps over washer/screw assemblies. **See Illustration #3.**
- E) Secure the outer edges of flare and end-cap using a single drill screw. **See Illustration #1 – Inset B.**

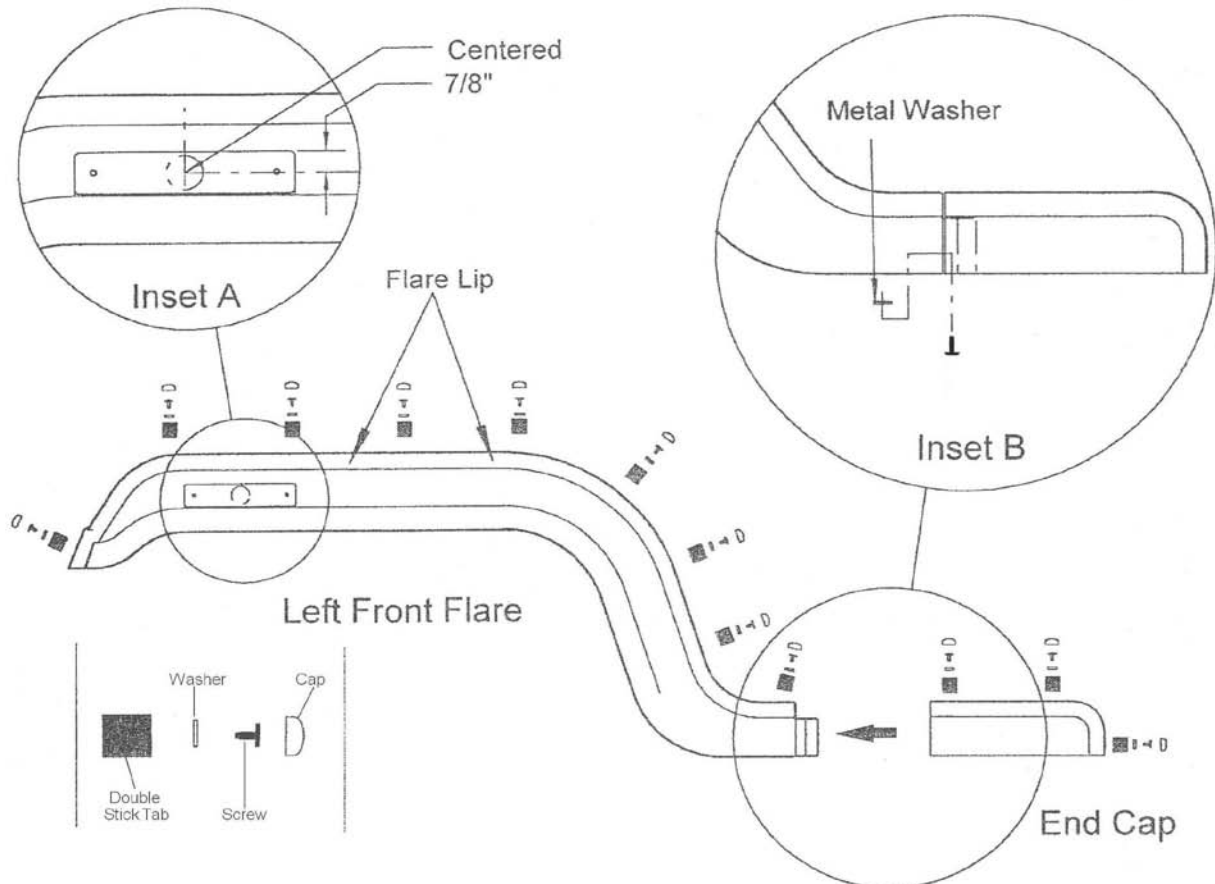

**Illustration #1**

#### Step 4: Marker Light Attachment (Front) (See Illustration #1)

Remount turn signal light frame inside light indent.

- A) Center and drill a 1-1/8" hole 7/8" from the top edge and an equal distance from both ends of the light indent. **See Illustration #1 – Inset A.**
- B) Locate and Drill two 11/64" holes by inserting the signal light frame into the 1-1/8" hole, and marking the existing screw positions.
- C) Secure signal light frame with supplied flat nuts over original screws.

Lengthen signal light wires to accommodate increased flare width.

- A) Cut original turn signal light wires 4" and 6" from signal bulb and strip all resulting wire ends.
- B) Insert four stripped ends into supplied connectors and crimp.
- C) Cut extension wire (supplied) into two equal lengths and strip all ends. Insert one extension wire into both vehicle-side connectors and crimp.
- D) Cut loom material (supplied) into two equal lengths. Thread vehicle-side wires through a single loom length and butt to existing loom material. Electrical tape can be used to hold old and new loom sections together.
- E) Thread loom through original signal light hole; insert vehicle-side wire ends into signal-side connectors and crimp.
- F) Insert signal bulb assembly into signal frame.

#### Step 5: Installing Flares (Rear)

Rear Flares are of one piece construction and do not require turn signal light remounting.

- A) Drill twelve 9/64" holes through the flare at the locations shown in **Illustration #2**. Holes should be drilled from the back to avoid marring the outer flare surface. Screw locations are marked as indents on the lip.
- B) Remove one side of the protective paper backing from the double-stick tabs and press onto the inside surface of the lip and over the holes drilled in Step 5A. **See Illustration #3.**
- C) Remove remaining paper backing and press flare into position on fender. Shield flare surface with duct tape or use drill bit extension to prevent marring by drill chuck and drill twelve 9/64" holes in fender through hole drilled in Step 5A.
- D) Secure flare to fender using supplied drill screws through washer. Press caps over washer/screw assemblies. **See Illustration #3.**

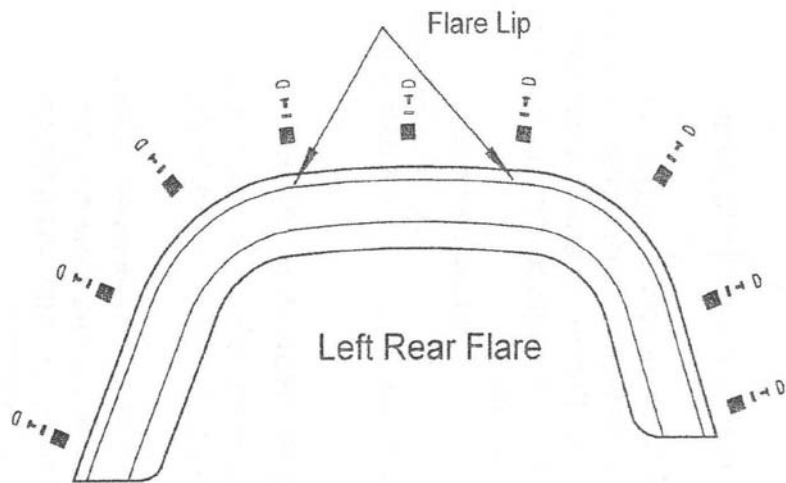

**Illustration #2**

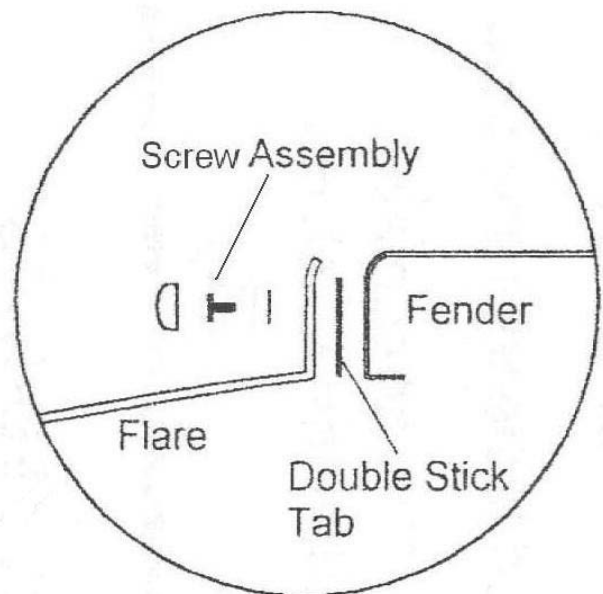

**Illustration #3**