



3651 N Highway 89 • Chino Valley, AZ 86323
(928) 636-7080 • www.p-a-g.net

JEEP WRANGLER ROCK SLIDER FRONT WINCH BUMPER INSTALLATION INSTRUCTIONS '07 - '10

**CENTERED FAIRLEAD FOR SMALLER
WINCHES KIT# 83206 / 83220 / 83210**

**OFFSET FAIRLEAD FOR LARGER WINCHES
KIT#83207 / 83221 83221 (PowerPlant)**

Before Starting Installation

NOTE
Kit parts are prefaced by the word *kit* and appear in **bold print**.

1. Carefully read all warnings and instructions completely before beginning.
2. Instructions are written for installation of both centered (83206/83210/83220) and offset (83207/83211/83221) bumper. Pay close attention for minor differences during install.
3. Verify all parts have been received in this kit by checking the parts list at the end of this document.

NOTE
If parts are missing from kit, please be prepared to provide the following information:
1. **Name** of purchase location
2. **Bar Code** on side of box
3. **Date** above bar code
4. **Date** inside box cover
5. **Inspector #** from inside box cover

⚠ WARNING
Before you install this kit, read and understand all instructions, warnings, cautions, and notes in this instruction sheet and in the vehicle owner's manual.

⚠ CAUTION
Proper installation of this kit requires knowledge of the factory recommended procedures for removal and installation of original equipment components. We recommend that the factory shop manual and any special tools needed to service your vehicle be on hand during the installation. Installation of this kit without proper knowledge of the factory recommended procedures may affect the performance of these components and the safety of the vehicle. We strongly recommend that a certified mechanic familiar with the installation of similar components install this kit.

⚠ WARNING
Many states and municipalities have laws restricting bumper heights and vehicle lifts. Consult state and local laws to determine if the changes you intend to make to the vehicle comply with the law.

⚠ WARNING
Always wear eye protection when operating power tools.

⚠ WARNING
Before you install this kit, block the vehicle tires to prevent the vehicle from rolling.

4. **Only install this kit on the vehicle for which it is specified.** If anytime during the installation you encounter something different from what is outlined in the instructions, call technical support at (928) 636-7080.
5. Park vehicle on a clean, dry, flat, level surface and block tires so vehicle cannot roll in either direction.

Engine Compartment

1. Disconnect both battery cables. Disconnect negative cable first, then positive cable.

Prepare to Install Bumper

1. Remove four bolts, two push clips and lower splash guard from lower crush zone and front bumper.

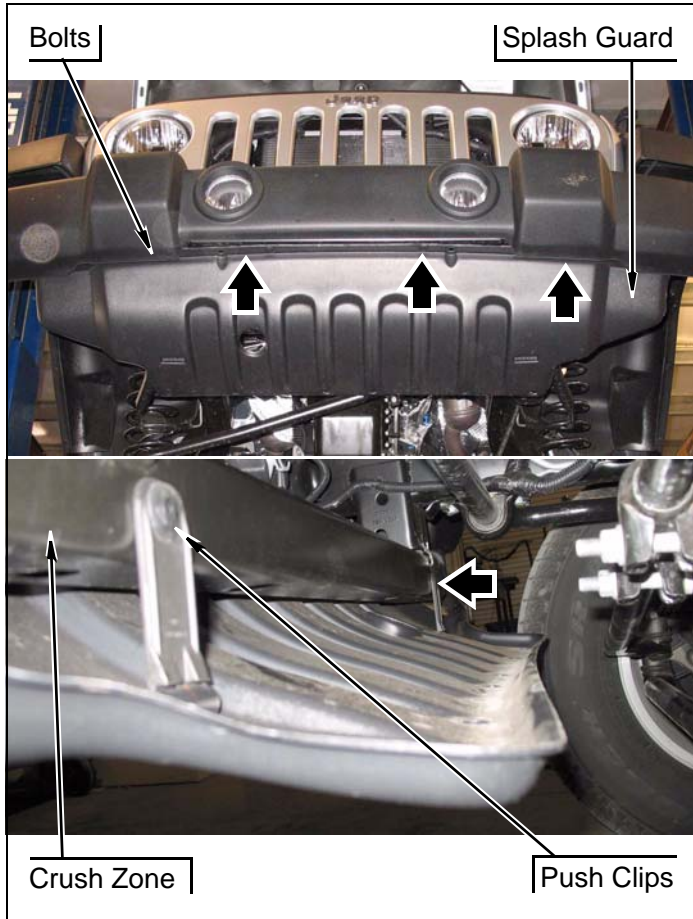

2. Disconnect fog lights wiring harnesses from fog lights if equipped.
3. Remove wiring harness and clips from lower crush zone.

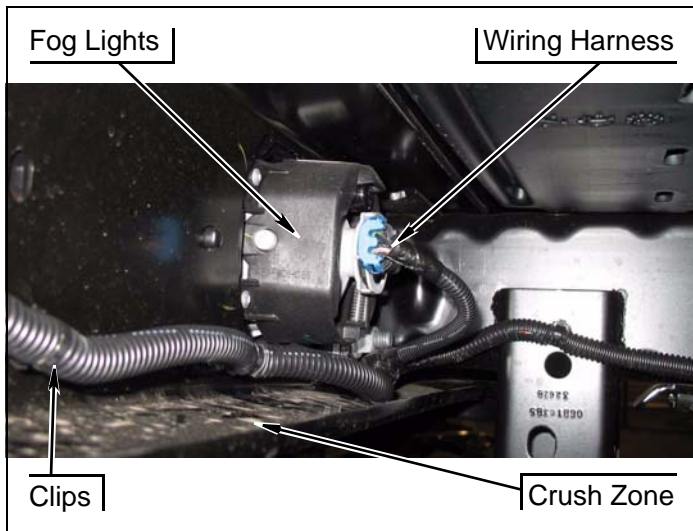

4. Remove four nuts, four spacer plates and front bumper from frame horns.

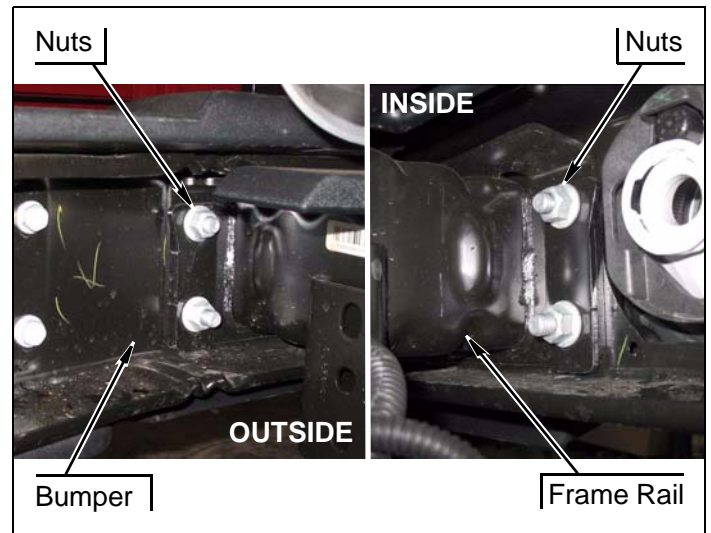

5. Remove eight screws and two fog lights from front bumper.

Install Bumper

NOTE
Bumper is designed to work with many Mile Marker and Warn Winches. Check measurements to verify fitment of winches before purchase. In general this bumper will fit smaller-midsized winches. For larger winches bumper P/N 83207 may be needed.

NOTE
Bumper can be installed without winch. Follow directions excluding winch install step directly below.

NOTE
Rear bend on winch plate may be opposite of pictured below.

NOTE
Center bumper plate shown below. Winch mount plate for offset bumper #83207 does not have triangle shaped tabs and holes are offset..

1. Bolt center winch mount plate to winch if installing. Triangle shaped tabs face upwards and towards the front of vehicle, position winch properly. Secure using hardware supplied with winch.

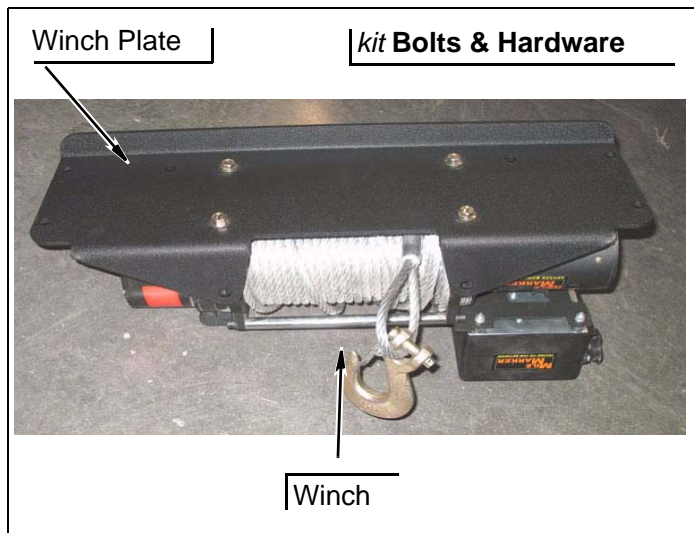

2. Position winch with **kit winch plate** bolted to it on top of OE crash bar between frame rails. Be careful

not to drop, use zip ties or similar device to temporarily secure if needed.

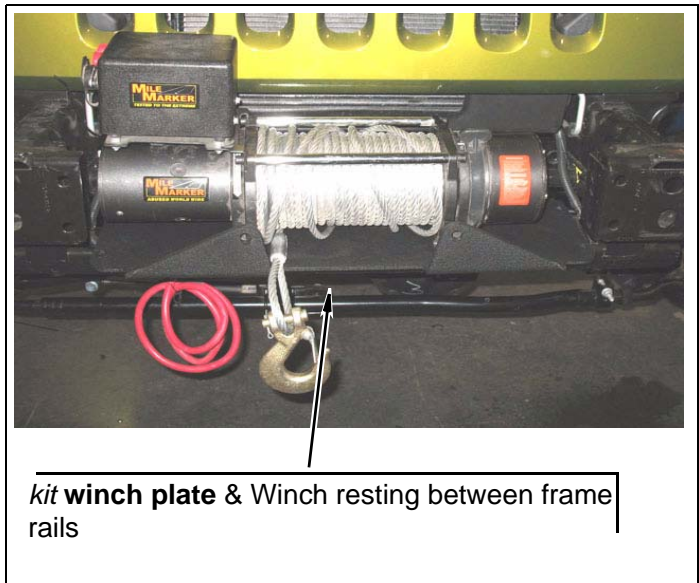

3. Position **kit D-Ring hooks** into **kit bumper**.

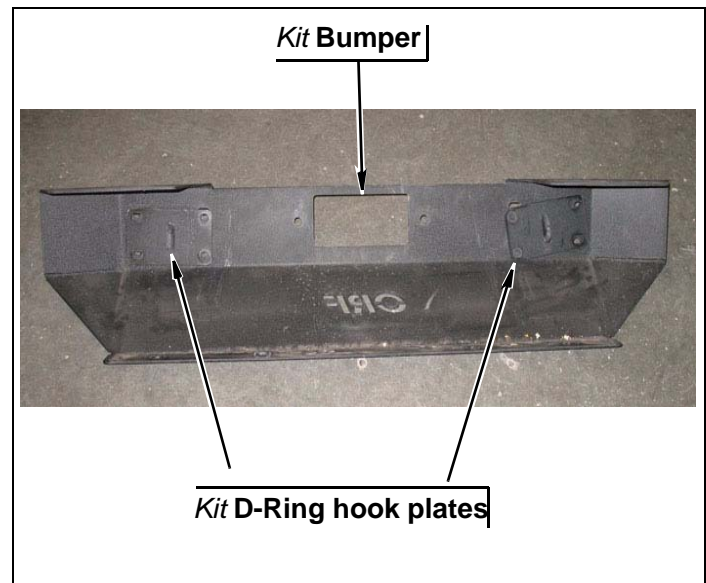

4. Lift **kit winch plate** off OE crash bar and position **kit main bumper** in position. Loosely secure on each

of the front outer holes with **kit bolts** (1/2"-1-1/4 Buttonhead) and **Flangenuts**.

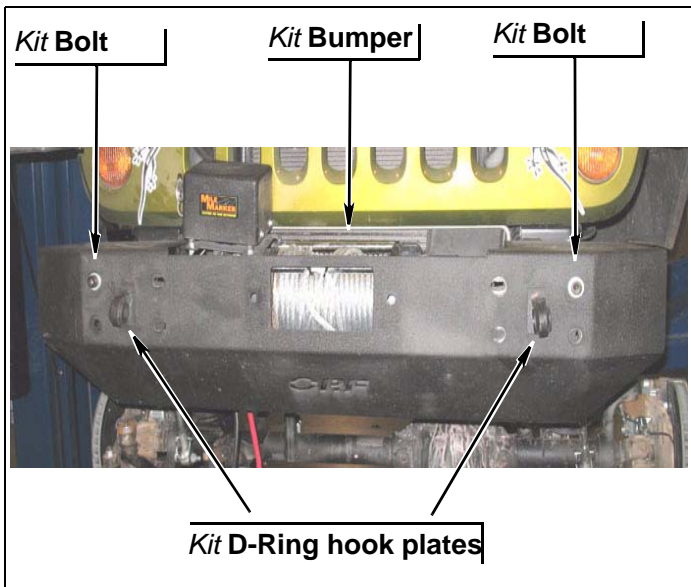

NOTE
 Pass winch sideplate may be shorter than driver to allow for clearance on jeeps with sway bar disconnect system. This change was made at a later date and is not reflected in the photo below.

5. Install kit winch sideplate

a. Identify **kit pass & drvr winch sideplates**.

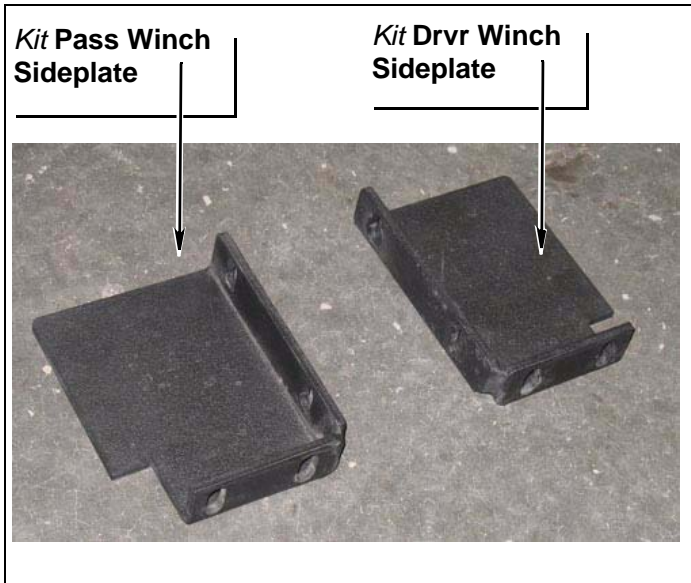

b. Carefully lift up winch and **kit winch base plate** and slide sideplate into position. **Kit winch base plate** should sit on top of lower lip of **kit sideplate**. Loosely secure **kit sideplate** to OE frame horn and **kit bumper** using **kit bolt** (1/2" x 1-1/2" Button Head) and **flange nut**.

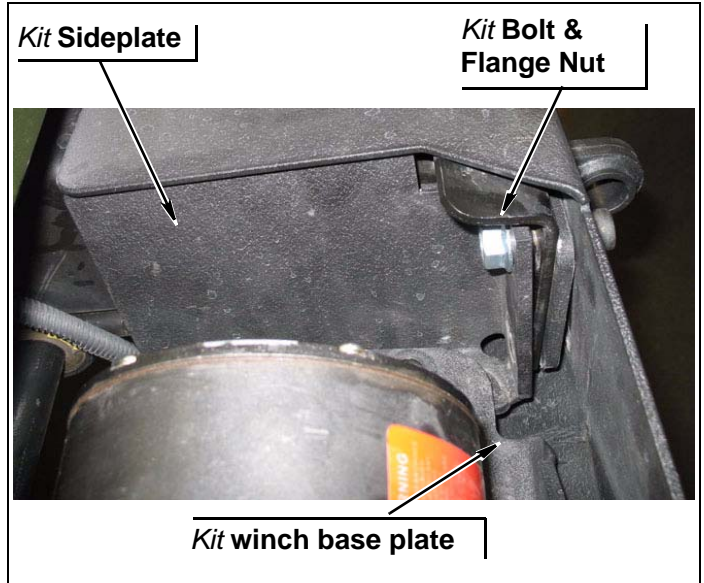

c. Loosely secure **kit winch base plate** to **kit sideplate** using four **kit bolts** (1/2" x 1" Hex Bolt) and **flange nuts**.

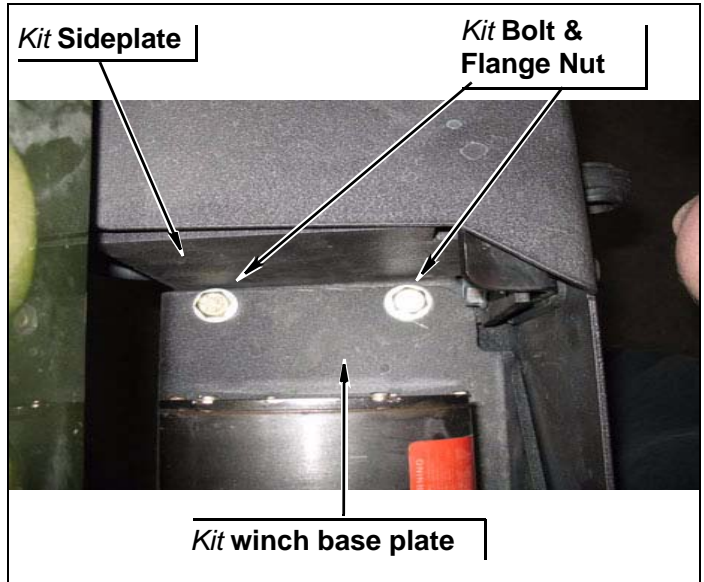

- d. Install two **kit bolts** (1/2" x 1 1/4" Button Head) and **flange nuts** through front face of bumper. Install winch fairlead at this point if using.

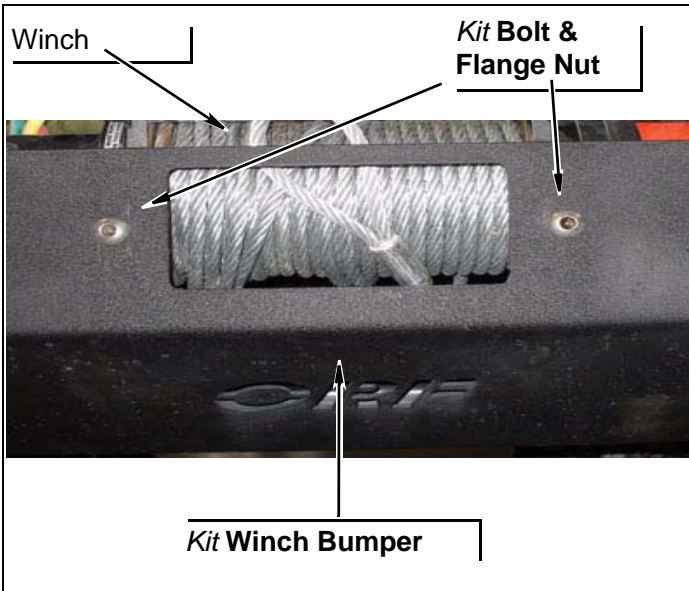

- e. Tighten all **kit hardware** installed up to this point.

6. Install two **kit bolts** (1/2" x 1-1/4" Button Head) with **large thick washer** and **locking nut** through outer holes on bottom of bumper. (Note: Some models are not equipped with this hole. It will be necessary to mark and drill a 1/2" hole to complete step 6.)

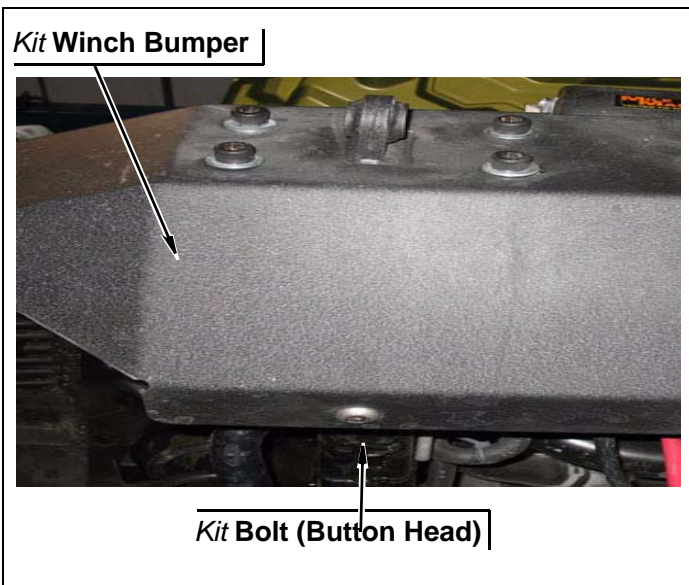

7. Install bottom center bolts with crush spacers.

△Note

If installing offset bumper #83207 only one of these bolt assemblies will be used on Driver's side of vehicle.

- a. Gather **kit hardware** (Bolt, 1/2" x 6", Crush Sleeve, 1/2" Washers, and 1/2" Flange Nut)

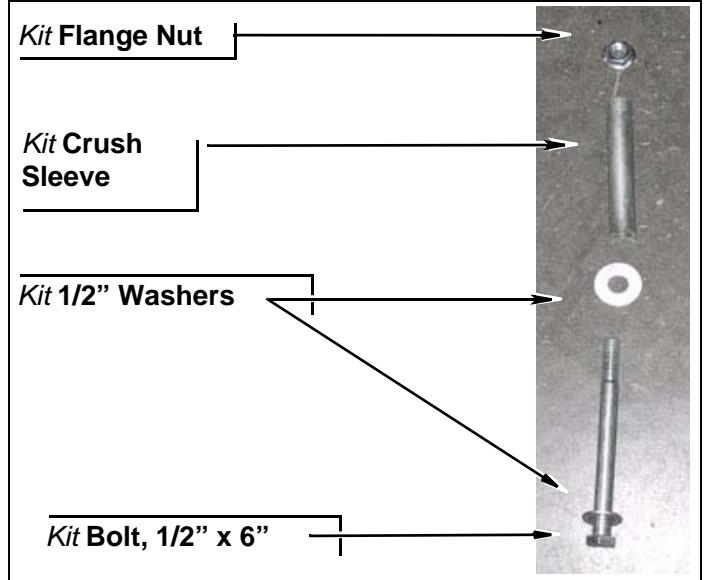

- b. Install **kit bolt and washer** through lower center hole from the bottom up. Install at least one **kit washer, 1/2"** on bolt on top of OE crash bar then install **kit crush sleeve**. Use additional washers to take up any gap between **kit winch plate, crush sleeve**, and OE crash bar. Secure with **kit Flange nut**.

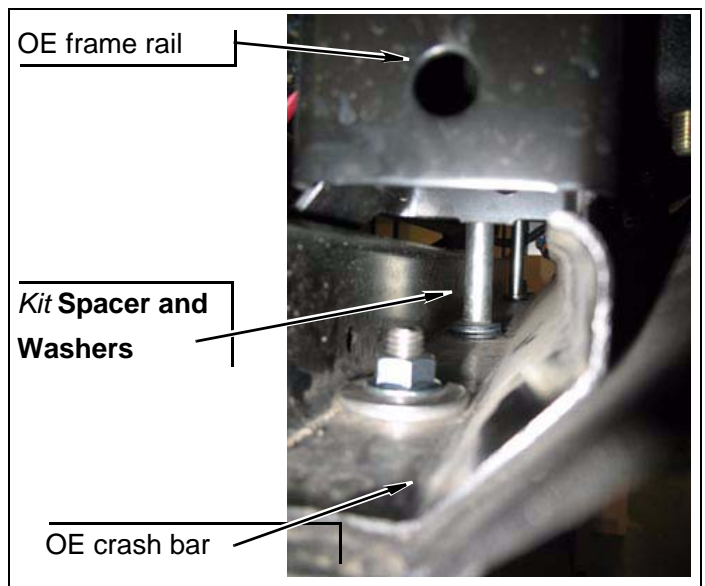

After Completing Installation

Engine Compartment

1. Connect both battery cables. Connect positive cable first, then negative cable.

Miscellaneous

1. Check all fasteners to ensure they are tight.
2. Ensure all wires, hoses, cables, etc. are properly connected and there is ample slack.

Dynamic Vehicle Check

1. Check steering in both directions to ensure that there is no bind. Check operation of clutch, brake system, and parking brake. Check operation of transmission and transfer case. Ensure there is full engagement in all gears and 4WD ranges. Check battery connections and electrical component operations. Test-drive vehicle.
2. Check steering and suspension in all positions to ensure that there is no bind and adequate clearance between all moving, fixed, and heated members. Check tire-to-bumper clearance and ensure no contact in any position. Test-drive vehicle.

⚠WARNING

Retorque all fasteners after 500 miles and after off road use. All body lift components should be visually inspected and fasteners retorqued during routine vehicle servicing.

⚠CAUTION

Performance Automotive Group does not recommend any particular wheel and tire combinations for use with its products and cannot assume responsibility for the customer's choice of wheels and tires. Refer to your owner's manual for recommended tire sizes and warnings related to the use of oversized tires. Larger wheel and tire combinations increase stress and wear on steering and suspension components, which leads to increased maintenance and higher risk for component failure. Larger wheel and tire combinations also alter speedometer calibration, braking effectiveness, center of gravity, and handling characteristics. Consult an experienced local off road shop to find what wheel and tire combinations work best with your vehicle.

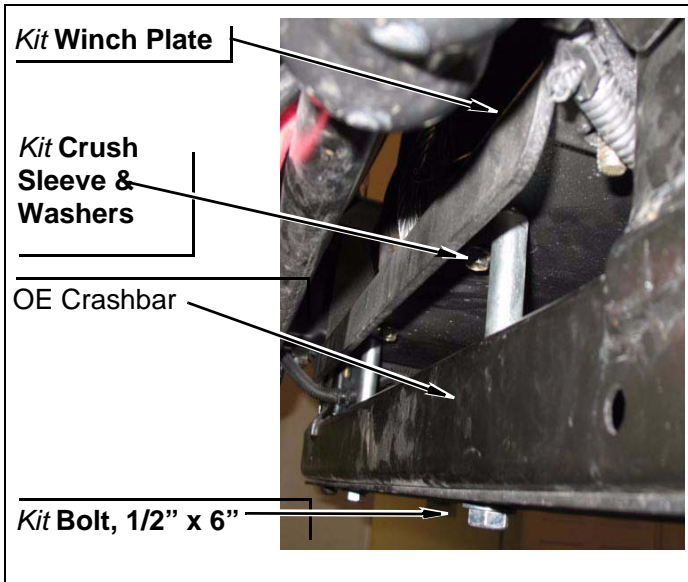

- c. Tighten all remaining bumper hardware.
8. If installing winch, consult manufacturers instructions for wiring and other installation and use notes.

NOTE

All warranty information, instruction sheets, and other documents regarding the installation of this product must be retained by the vehicle owner. Information contained in the instructions and on the warranty card will be required for any warranty claims. The vehicle owner needs to understand the modifications made to the vehicle and how they affect vehicle handling and performance. Failure to provide the customer with this information can result in damage to the vehicle and severe personal injury.

Kit Parts List

Qty. Description

1	Bumper
1	Winch Plate
2	D-Ring Plate
1	Sideplate, Drvr
1	Sideplate, Pass
1	Hardware Pack
9	Bolt, Button Head (1/2"-13 x 1-1/4")
4	Bolt, Button Head (1/2"-13 x 1-1/2")
2	Bolt, Hex Head (1/2"-13 x 6") *Centered only
1	Bolt, Hex Head (1/2"-13 x 6") *Off set only
4	Bolt, Hex Head Gr. 8 (1/2"-13 x 1")
10	Washer, Flat (1/2")
18	Nut, Flange (1/2"-13)
2	Sleeve, (.75 x .090 x 4.275) *Centered only
2	Sleeve, (.75 x .090 x 4.275) *Off set only
4	Large Thick Washer
2	D-Rings